

# FABRICATION AND EVALUATION OF SPECIALTY NONWOVEN MATERIALS

A Dissertation  
Submitted to the Graduate Faculty of the  
Louisiana State University and  
Agricultural and Mechanical College  
in partial fulfillment of the  
requirements for the degree of  
Doctor of Philosophy

In

The School of Human Ecology

by

Nan Jiang

B.S., Southern Yangtze University (Wuxi University of Light Industries), June 2001

M.S., Southern Yangtze University (Wuxi University of Light Industries), June 2004

December 2008

## **Acknowledgements**

I would like to express my gratitude to Dr. Yan Chen, my major professor, for his continuous guidance and constant encouragement. I have learned a lot from such a knowledgeable and considerate scholar.

I would also like to extend my appreciation to my committee members, Dr. Jenna Kuttruff, Dr. Ioan Negulescu, Dr Kevin S. McCarter, Dr. Robert Laird and Dean's Representative Dr. Kent Mathewson. I would like to thank all of them for kindly serving on my committee.

I also acknowledge my thanks to the Louisiana Board of Regents for the funding support through the Governor's Biotechnology Initiative. Thanks are also extended to the LSU Graduate School for financial support of the grant of Economic Development Assistantship.

Also I want to thank my friends Dr. Tom Sun, Yao Zeng, Xiaozhou Huang, Juanjuan Yang, Qi Yan, He Fang, who offered a lot of help during my four years Ph.D study.

Last but not least, I would like to thank my husband Yin Yang and my parents for their spiritual support. This dissertation would not appear without their consistent encouragement, love, and patience.

## Table of Contents

Acknowledgements.....	ii
List of Tables.....	v
List of Figures.....	vi
Abstract.....	viii
Chapter 1 Review of Literature.....	1
1.1 Introduction.....	1
1.2 Research Objectives.....	2
1.3 Arrangement of this Research.....	3
1.4 Literature Review.....	4
1.4.1 Nonwovens Fabrics.....	4
1.4.1.1 Nonwoven Web Formation.....	5
1.4.1.2 Nonwoven Web Bonding.....	8
1.4.1.3 Market of Nonwovens.....	9
1.4.2 Cellulose Fibers – Cotton and Rayon.....	10
1.4.2.1 Cotton.....	10
1.4.2.2 Rayon.....	11
1.4.3 Activated Carbon.....	13
1.4.3.1 Structure of Activated Carbon.....	13
1.4.3.2 Production of Activated Carbon.....	14
1.4.3.3 Applications of Activated Carbon.....	18
1.4.3.4 Porosity in Carbon.....	20
1.5 Methodology.....	25
1.5.1 Experimental.....	25
1.5.1.1 Nonwovens Fabrication.....	25
1.5.1.2 Carbonization and Activation.....	26
1.5.2 Evaluation.....	28
1.5.2.1 Mechanical Property.....	28
1.5.2.2 Thermal Property.....	28
1.5.2.3 Scanning Electron Microscope (SEM) Test.....	29
1.5.2.4 Measuring Porosity and Surface Area.....	29
1.5.2.5 Acoustical Properties.....	31
1.6 References.....	33
Chapter 2 Preparation and Surface Characterization of Fibrous Activated Carbon From Cotton Nonwoven.....	37
2.1 Introduction.....	38
2.2 Experimental.....	38
2.2.1 Nonwovens Fabrication.....	38
2.2.2 Carbonization and Activation.....	38
2.3 Results and Discussion.....	38

2.3.1 Pore Characteristic.....	38
2.3.2 Fabric Tensile Strength.....	42
2.3.3 SEM Images .....	42
2.4 Conclusions.....	44
2.5 References.....	45
Chapter 3 Focus Study on Preparation and Characterization of Cotton and Viscose Rayon Nonwovens.....	48
3.1 Introduction.....	48
3.2 Experimental.....	50
3.2.1 Activated Carbon Fiber Production.....	50
3.2.2 Characterizations.....	51
3.3 Results and Discussion.....	52
3.3.1 Weight Loss Behavior .....	52
3.3.2 Surface Characterization of Activated Carbon Fibers.....	53
3.3.3 Physical Activation VS Chemical Activation.....	61
3.3.4 Repeating Test.....	64
3.3.5 X-Ray Diffraction Data.....	64
3.4 Conclusions.....	65
3.5 References.....	66
Chapter 4 Acoustical Evaluation of Carbonized and Activated Cotton Nonwovens.....	69
4.1 Introduction.....	69
4.2 Experimental.....	70
4.3 Results and Discussion.....	71
4.3.1 Sound Absorption.....	71
4.3.2 Transmission Loss.....	74
4.4 Conclusions.....	75
4.5 References.....	76
Chapter 5 Conclusions and Future Work.....	78
5.1 Conclusions.....	78
5.2 Future Work.....	81
Appendix: Permission Letter.....	83
Vita.....	85

## List of Tables

Table 1 Surface Area, Pore Volume and Pore Diameter .....	40
Table 2 Comparison of N <sub>2</sub> and CO <sub>2</sub> Adsorption.....	41
Table 3 Tensile strength of Nonwoven Fabrics .....	42
Table 4 Surface Characteristics of Rayon and Cotton.....	53
Table 5 P Value of ANOVA.....	59
Table 6 Surface Area, Pore Volume and Pore Diameter .....	63
Table 7 Surface Area Repeating Test .....	64
Table 8 Fiber and Nonwoven Specifications .....	71
Table 9 Means of Sound Absorption Coefficient ( $\bar{\alpha}$ )* .....	73
Table 10 Means of Transmission Loss ( $\overline{TL}$ )* .....	75

## List of Figures

Figure 1 Basic construction of carding machine and its parts (Russell 2007).....	6
Figure 2 Basic construction of needle punching machine .....	8
Figure 3 Structure of Cellulose (Chaplin 2008).....	10
Figure 4 Elementary Graphitic Crystallites (Smisek & Cerny 1970).....	13
Figure 5 Pore shape models (Patrick 1995).....	21
Figure 6 Isotherm shapes (Patrick 1995) .....	22
Figure 7 Carding Machine .....	25
Figure 8 Needle Punching Machine.....	26
Figure 9 Nonwoven Processing .....	26
Figure 10 Clean Room Oven .....	27
Figure 11 Carbonization and Activation Procedures .....	27
Figure 12 Carbonization and Activation Instrument (ASAP 2020).....	28
Figure 13 Physisorption Analyzer .....	30
Figure 14 Sound Adsorption Measuring System Configuration.....	31
Figure 15 Sound Transmission Loss Measurement System .....	32
Figure 16 Adsorption Isotherms of N <sub>2</sub> at 77K at various carbonization Temperatures.....	39
Figure 17 Raw Cotton.....	43
Figure 18 Carbonized Cotton.....	43
Figure 19 Carbonized and Activated Cotton .....	44
Figure 20 Thermal Analysis of Cotton Nonwoven.....	52
Figure 21 Yield Curves of Rayon and Cotton for Treatment Time Effect.....	54
Figure 22 Surface Area of Rayon and Cotton for Treatment Time Effect .....	55

Figure 23 Pore Diameter Rayon and Cotton for Treatment Time Effect .....	56
Figure 24 Yield of Rayon and Cotton for Treatment Temperature Effect .....	57
Figure 25 Surface Area of Rayon and Cotton for Treatment Temperature Effect .....	57
Figure 26 Pore Size of Rayon and Cotton for Treatment Temperature Effect .....	58
Figure 27 3D Surface Area on Temperature and Time (figure con't.) .....	59
Figure 28 3D BJH Pore Diameter on Temperature and Time (figure con't.).....	60
Figure 29 Isotherm Curves of Cotton Fibers obtained at 800 C for 4 Hours.....	62
Figure 30 X-Ray Diffraction of Cotton Fiber before and after Carbonization .....	65
Figure 31 Acoustical Nonwoven Structure.....	71
Figure 32 Sound transmission loss measurement system .....	72
Figure 33 Transmission Loss of Nonwovens.....	74

## Abstract

The present work is to develop multifunctional materials with high performance on chemical absorption, adsorption and on acoustic absorption and insulation using natural fiber nonwovens via carbonization and activation. Evaluation of these textile materials includes tensile strength, thermogravimetric analysis, sound absorption and transmission loss, scanning electronic microscopy and surface properties.

Carbonization of cotton nonwoven was carried out in a high temperature oven with nitrogen between 300 °C and 500 °C. The physical activation was undertaken using CO<sub>2</sub>. The N<sub>2</sub> adsorption isotherm curves of the cotton nonwoven showed the presence of micropores and macropores. High BET surface area and average pore diameters closed to micropores were obtained. The comparison between the N<sub>2</sub> and CO<sub>2</sub> adsorption showed that BET surface area for N<sub>2</sub> adsorption is much smaller than that for CO<sub>2</sub> adsorption and median pore width for the N<sub>2</sub> adsorption is greater than that for CO<sub>2</sub> adsorption due to the activated diffusion effects.

Intensive research has been done with an emphasis on how to optimize the method of carbonizing and activating cotton nonwoven. ACF made from rayon fabrics showed slightly high surface area than cotton. The carbonization and activation temperature increase leads to samples with high adsorptive capacity and microporosity. Longer heating time also contributes to high surface area, but widens microporosity and develops of mesopores. Surface area of 879.05 m<sup>2</sup>/g and BJH average diameter of 27.67 Å were achieved when rayon was carbonized and activated at 800 °C for 4 hours. Cotton could endure longer heating time up to 5 hours at 800 °C than rayon and surface area of cotton ACF as high as 982.10 m<sup>2</sup>/g. Chemical activation method was also investigated by impregnation of cotton fabric with ZnCl<sub>2</sub>, which increasing final ACF yield, surface area and developing micropores.

A nonwoven composite of ACF with cotton nonwoven as a base layer was developed. The study concluded that the ACF composite exhibited a greater ability to absorb normal incidence sound waves than the composites with either glassfiber or cotton fiber. The analysis of sound transmission loss revealed that the three composites still obeyed the mass law of transmission loss. The ACF composite exhibits great sound absorption and sound insulation properties.

# Chapter 1 Review of Literature

## 1.1 Introduction

This dissertation addresses the research in the area of advanced high-performance activated carbon fiber and fabrics. The overall purpose of this research is to develop multifunctional materials with high performance on chemical absorption, adsorption and desorption and on acoustic absorption and insulation using natural fiber nonwovens via carbonization and activation.

Currently, major fiber precursors for producing commercial activated carbon fiber (ACF) fabrics include rayon, acrylic, polyacrylonitrile (PAN), and Novoloid (novolac resin). In this research, a nonwoven fabric material made from cellulose-based fibers has been studied because of their low cost, sustainability and biodegradability. Research efforts are focused on production and evaluation of activated carbon fabrics. A nonwoven is made from cellulosic fibers using the nonwoven techniques of carding and needle-punching and is carbonized and activated in a gas tight oven with controlled temperature and gas flow. Evaluation of these textile materials includes mechanical properties, thermal properties (thermogravimetric analysis), acoustical properties (absorption and transmission loss), microporous surface structure (Scanning Electronic Microscopy) and surface properties (surface area, micropore volume, micropore size distribution). By evaluating the properties of the activated carbon nonwoven, the optimum conditions of the manufacturing process as maximum temperatures and holding times of carbonization and activation, temperature increasing rate and gas flow rate will be determined. The characteristics especially physical absorption properties of cotton based activated carbon are compared with rayon based activated carbon. In the activation step, physical and chemical methods are used widely. Chemical activation is carried out by impregnating raw material with an activating agent such as phosphoric acid, zinc chloride or sulfuric acid, which will produce

negative effects on the environment protection (Smisek & Cerny 1970). Thus, physical activation is mainly employed in this research and only initial data of chemical activation is discussed.

This research emphasizes exploring unique fabric architecture of activated carbon fiber fabrics: macropores among fibers and yarns; and micropores on the surface of activated carbon fiber. This structure renders great potential for the activated carbon fiber fabrics to be used as high-performance and cost-effective materials focused on personal safety equipment (protective clothing and masks), solvent recovery, water/air purification, wastewater treatment, and heat and electric insulation. However, there is a lack of reports on activated carbon fiber materials for acoustical applications. Textile fabrics, particularly nonwoven fabrics, have also been commonly used for sound absorption, because of a special structure formed by fiber and yarn in fabrics. This dissertation covers the fundamental studies, engineering process and industrial applications for the activated carbon nonwoven fabrics. This research will have an impact on economic development in Louisiana and other southern states that produce cotton in large quantities by converting agricultural by-products to value added products. This research will also help tailor excellent fiber and fabric properties into the high performance and cost-effective materials with great potential end uses.

## **1.2 Research Objectives**

The objectives of the research are to investigate the process of manufacturing activated carbon nonwoven made from natural fibers. The process is focused on nonwoven formation, carbonization, and activation of nonwoven fabrics. Natural fiber cotton and man-made fiber rayon as raw materials are compared with each other. Physical activation is mainly employed in this research because of its environmental friendliness, but initial data of chemical activation is also discussed.

In industrial applications, nonwoven-based activated carbon materials should satisfy certain performance expectations. In this way, one of the research goals is to identify testing methods and techniques that will allow assessment of performance of the final activated carbon products according to the physical and chemical characteristics. Evaluation of these textile materials includes mechanical properties, thermal properties, acoustical properties, surface structure and surface properties. By evaluating the properties of the activated carbon nonwoven, the optimum conditions of the manufacturing process in terms of maximum temperatures, and thermal decomposition time of carbonization and activation of manufacturing ACF materials will be determined.

However, these ACF materials made from cellulose-based fibers tend to have weak mechanical properties after carbonization and activation. This may limit some prospective end uses for ACF materials. Research is needed to find approaches for improving mechanical properties of the ACF materials by means of new textile techniques and process control of carbonization and activation.

Another major purpose of the research is to explore potential end uses of carbonized and activated cotton nonwoven as a high-performance adsorbent and absorbent used as biodegradable acoustic materials for specialty industrial applications. This study investigates these application potentials by characterizing surface microporous structures of the activated carbon fiber nonwovens.

### **1.3 Arrangement of This Research**

The dissertation is arranged in three parts. The first part discusses the overall objectives of the overall research regarding the manufacture procedures and evaluation techniques. The literature review discusses web formation, bonding methods and industrial applications of nonwoven fabrics; comparison of structures of rayon and cotton; and production and micro

structure of activated carbon. The experimental methods along with all processing and testing procedures will be included.

The second part is composed of three proposed articles. In each article, results and discussion are discussed in details. The first one composed as Chapter 2 reports the production of carbonized and activated cotton nonwovens and the evaluation of their microporous properties. The second article exhibited as Chapter 3 describes the optimum conditions of the manufacturing process of carbonization and activation. Maximum temperatures and holding times will be determined. Meanwhile, properties of rayon-based and cotton based carbon fiber are compared. The third article in chapter 4 proposes a nonwoven composite of activated carbon fibers with cotton nonwoven as a base layer. Acoustical evaluation results show that the carbonized and activated cotton nonwovens have a potential to be used as high-performance and cost-effective acoustical materials.

## **1.4 Literature Review**

### **1.4.1 Nonwoven Fabrics**

The term “Nonwoven” came into use half a century ago when nonwovens were regarded as low-price substitutes for traditional textiles. EDANA, (The European Disposables and Nonwovens Association) defines a nonwoven as ‘a manufactured sheet, web of directionally or randomly orientated fibers, bonded by friction and/or cohesion and/or adhesion’ (EDANA 2008), while INDA, North America’s Association of the Nonwoven Fabrics Industry, describes nonwoven fabrics as ‘sheet or web structures bonded together by entangling fibers or filaments, by various mechanical, thermal and/or chemical processes. These are made directly from separate fibers or from molten plastic or plastic film’ (INDA 2008). Nonwovens are engineered fabrics that can form products that are disposal, for short-term use or durable, with long life, depending on the application.

The common products made by nonwovens listed by INDA include (INDA 2008):

- Disposal diapers, napkins and tampons, personal wipes, laundry aids
- Apparel interlinings, labels
- Carpeting and upholstery fabrics, padding and backing, automotive headliners and upholstery, roofing products
- Agricultural coverings and seed strips, civil engineering fabrics/ geotextiles

Hygiene is by far the largest of these categories, accounting for around 33%, followed by civil engineering/ construction and building materials with 17.9%. With a great concern to environmental problems, more and more nonwoven composites are used in automotive interior parts for their excellent biodegradability and strength (Chen et al. 2005). Recent innovations in the filtration market include the use of nonwoven nanofiber filter offering enhanced particle capture properties or the use of electrostatically charged filter providing an anti-bacterial barrier (Palexpo 2005).

#### 1.4.1.1 Nonwoven Web Formation

Nonwoven fabrics are based on the web formation. The characteristics of the web determine the physical properties of the final products. Generally, nonwovens are divided into three major areas: dry-laid, wet-laid and polymer-laid (Russell 2007). The choice of methods for forming webs is mainly determined by the length of fibers.

- Dry Laid

The staple fibers of Dry-laid nonwovens are long enough to be handled by spinning machines and are usually 1.2cm to 2.0 cm or longer. The dry-laid nonwoven is formed by utilizing carding or air-laying methods and converting staple fibers into a web structure that is uniform in weight per unit area. Man-made fibers account for the majority of raw materials used in the nonwovens industry, and in the carding sector polyester is most widely used followed by

polypropylene. Viscose rayon is extensively used in the hygiene disposables and medical sectors for its high moisture regain. Natural fibers, especially cotton are often used to manufacture, for example, feminine hygiene and absorbent medical products (Russell 2007).

In carding, the main objective is to disentangle and mix fibers to convert fibers into a form of a homogeneous web. The large rotating metallic cylinder is the heart of the carding machine and is the central distributor of fiber during the process. The cylinder is partly surrounded by an endless belt and the worker-stripper pairings around the perimeter of the cylinder have both a carding and mixing function. The doffer rollers condense and remove fiber from the cylinder in the form of a continuous web (Russell 2007).

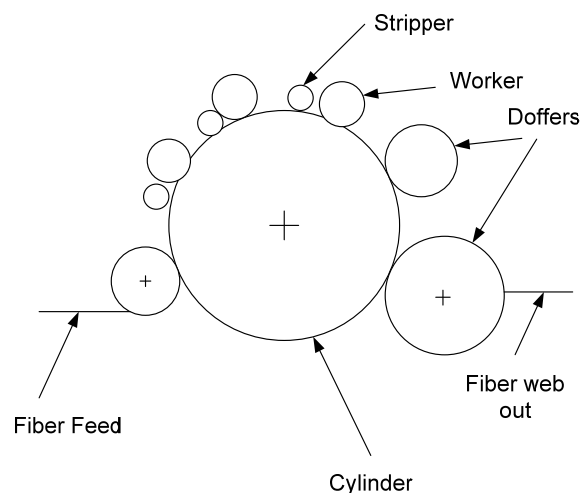

Figure 1 Basic construction of carding machine and its parts (Russell 2007)

Air-laying (aerodynamic) is a family of dry-laid web formation processes and the characteristic of air-laid webs is their isotropicity. Air-laying involves dispersing fibers in airstream and leading these fiber mixtures towards the conveyor or permeable screen where the fiber is separated and deposited in a form of web. Usually the webs made from air-laid are lighter than  $30\text{g/m}^2$  due to the weight limitation. Therefore, airlaid nonwovens are more expensive than carded nonwovens.

- Wet Laid

Wet-laid has its origins in the papermaking process. In light of physical property differences between paper and textiles, paper would be weak, stiff, inextensible, smooth, and dense, while textiles would be stronger, softer, bulkier, more drapeable, less smooth and more porous. Whether or not a fiber is suitable for use in the web process depends on its ability to disperse in an aqueous medium. After swelling and dispersion of the fibers in water, the mixing vats are transported to a head box from where they are fed continuously into a web-laying machine. A suitable system has been found for creating a homogeneous web out of synthetic and long natural fibers from which the web is formed. This includes incorporating an adequate length of time from a prepared suspension and controlling the resistance of the web to filtration as it is being formed (Russell 2007).

- Polymer Laid

Polymer laid nonwoven fabrics are produced by the extrusion spinning processes, in which filaments are directly collected to form a web instead of being formed into yarns as in conventional spinning (Russell 2007). Polypropylene, polyester, polyamide, polyurethane and rayon are widely used in polymer-laid nonwovens.

The two main polymer-laid processes are spun bonding and melt blowing. They are similar in principle but the processes are quite different. Spunbond fabrics are produced by the following steps: forming filaments by extruder, spinning filament, drawing and depositing filaments onto a collecting belt, and bonding the fibers by mechanical or thermal methods. Spunbond products are used in automotive, civil engineering, hygiene and medical products, packaging materials. Melt blowing is a process, in which, a polymers or resins is extruded through a linear die containing several hundred small orifices. High-velocity air or another appropriate force rapidly attenuates the filaments to form fine diameter fibers (1-5  $\mu\text{m}$ ). The

fibers are blown on a conveyor and form a fine fibered web. This process is important because it is the almost exclusive method to produce microfibers which are widely used in industrials (diameter is less than 10  $\mu\text{m}$ ) (Russell 2007).

#### 1.4.1.2 Nonwoven Web Bonding

There are three major bonding types: mechanical bonding, thermal bonding and chemical bonding. Bonding may be carried out in line with web formation or as a separate and distinct operation.

Mechanical methods include needle punching, stitch bonding and hydrogen tangling. Figure 2 illustrates the basic principle of needle punching technique. The fiber web is mechanically oriented and entangled by thousands of barbed felting needles repeatedly passing into and out of the web. As the web moves through the needle punching machine, more fibers are progressively entangled by the needle barbs and a coherent structure is formed. Typical applications of needle punched fabrics are medical wound dressings, filter media, wadding and padding, floor coverings, automotive fabrics, blankets and wipes.

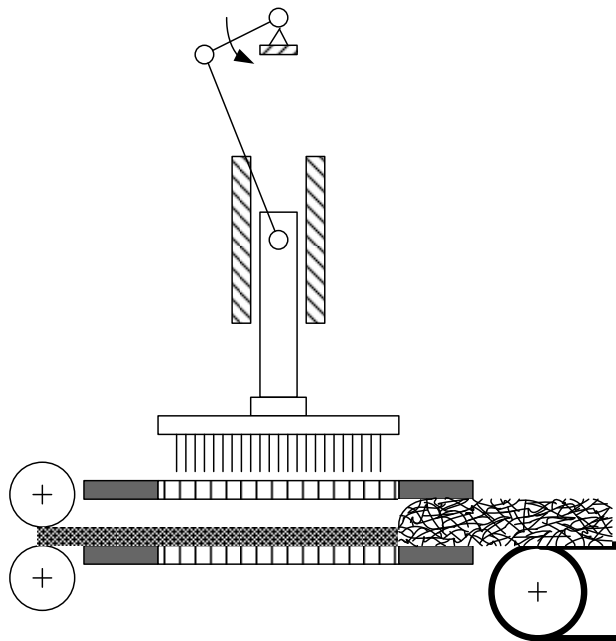

Figure 2 Basic construction of needle punching machine

Thermal bonding uses heat and pressure to soften and then fuses or welds fibers together below melting temperature. It requires a thermoplastic component in the form of a fiber, powder, or film, as part of a bicomponent fiber. Thermal bonding of nonwoven webs go through three steps: heating the webs, forming a bond through polymer and fiber-fiber interface, and cooling the fibers. Thermal bonding has good economic efficiency compared to chemical bonding and is environmentally friendly since no chemical binders are required during the manufacturing process (Gillies 1979).

Chemical bonding methods involve applying adhesive binders to webs by saturating, spraying, printing, or foaming techniques. The physical properties of a chemically bonded nonwoven, especially the strength, are determined by the fiber, the polymer, the additives, and the interaction. The chemical binders most frequently used to consolidate fiber webs are latexes because they are economical, versatile, and easy to apply. Most latex binders are made from vinyl materials such as polyvinylacetate, polyvinylchloride, styrene/butadiene resin, butadiene, and polyacrylic, or their combinations. The amount of chemical binders employed on webs can be between 5% and 60% by weight. The common methods of applying a binder material on webs include saturation, foam, spray, print and powder bonding (Russell 2007).

#### 1.4.1.3 Markets of Nonwovens

The total global nonwovens production is 5.75 million tons in 2007 and will be reach to 8.41 million tons in 2012 with a steady average annual growth of 7.9% (Butler 2008). Strong growth of the Asian pacific nonwoven industry, especially China with an average annual growth of 18% in recent ten years, is noticeable. In web forming technologies, spunlaid and carded nonwovens are dominant for their low cost and high efficiency. According to the American magazine Nonwovens Industry, the total combined estimated sales of the top 42 nonwovens companies accounted for more than 90% of total global nonwoven sales. The top five giant

companies are Freudenberg (Germany), DuPont (US), Kimberly-Clark (US), BBA Fiberweb, and PGI Nonwovens (McIntyre 2008).

## 1.4.2 Cellulose Fibers – Cotton and Rayon

### 1.4.2.1 Cotton

Cotton is the most important vegetable fiber used in spinning and is widely grown in tropical and subtropical regions all over the world. The earliest cultivation of cotton used in cloth was as early as 3000 B.C. The average cotton plant is an herbaceous shrub having a normal height of about 4-6 feet. The best growth conditions for cotton include a warm and fairly moist climate. In 2007-2008, China (29%), India (21%) and U.S. (16%) are the three leading countries of cotton production (O'Regon 2008).

Cotton is pure cellulose with high water absorption. The hydrogen bond formed between cellulose molecule and water molecule helps cotton to absorb water well (Collier & Tortora 2001).

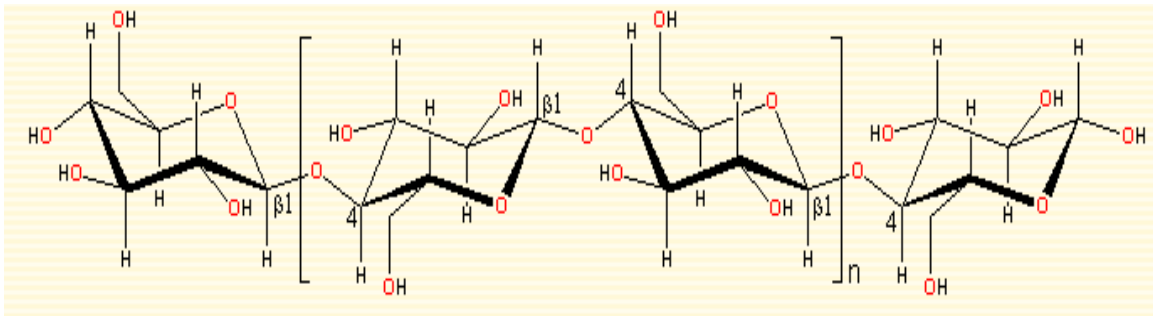

Figure 3 Structure of Cellulose (Chaplin 2008)

The most striking characteristic is that the cotton fibers have a hollow structure. Their cross-sectional shapes range from circular, to elliptical and often are referred to as resembling kidney beans (deGruy et al. 1973). Cotton has good absorbency and moisture regain, which makes cotton comfortable as the material directly touching skin (Collier & Tortora 2001). Recent research on cotton focuses on reducing the cost of production and extends its end uses on high-

value final products. Good properties of cotton fiber will enhance end use performance of cotton based industrial applications.

#### 1.4.2.2 Rayon

In 1891, the British chemists Charles Cross and Edward Bevan discovered that cotton or wood cellulose could be dissolved into a soluble compound (Woodings 2001). The solution of this compound passes through the spinneret then forms soft filaments. The types of commercial rayon fibers are classified by the process by which the cellulose is converted into the soluble form. The following section will discuss different cellulose solutions in details.

- Cellulose Nitrate

Cellulose dissolved in alcohol and ether forms soft strong cellulose nitrate fibers and can be woven into fabrics. But these fibers have a very serious drawback that prevents their widespread use in textiles: they are very flammable. Chardonnet started up the first factory to manufacture rayon in 1892 by treating mulberry leaves with nitric and sulphuric acids to form cellulose nitrate (Woodings 2001). The solution was then extruded through holes in a spinneret. Warm air was used to evaporate the solvent to obtain solid cellulose nitrate filaments. The first artificial fiber process has the disadvantages that denitration of fibers spoiled their strength and appearance and the process is difficult to scale-up safely and relatively uneconomic compared with later routes.

- Dissolution in Cuprammonium Hydroxide: Cupro

The second commercialized rayon process was based on cotton dissolved in a solution of copper salts and ammonia. Cuprammonium solution of cellulose could be extruded into water, with dilute sulphuric acid being used to neutralize the ammonia. This process is still used today especially in medical disposable fabrics. However the relatively high costs of cotton and copper salts prevented it from reaching large scale manufacture.

- Dissolution via Cellulose Xanthate: Viscose

Cotton or wood cellulose could be dissolved as cellulose xanthate following treatment with alkali and carbon disulphide (Woodings 2001):

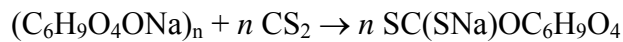
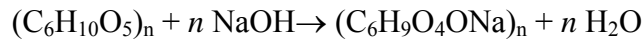

The solution can be coagulated in an ammonium sulphate bath and converted back to pure white cellulose using dilute sulphuric acid. Through this route, short fiber cellulose (wood pulp) is converted to a spinnable solution and then into longer filaments, which can be precisely controlled in terms of length, fineness, physical properties and cross-sectional shape. However, increasingly stringent environmental legislation has forced the viscose industry to employ more and more effective systems for recovering CS<sub>2</sub> and H<sub>2</sub>S. The majority of acid and zinc used during spinning is also pollution to the environment. The later stages of the washing process result in more and more dilute waste streams and consume a lot of water and energy.

- Direct Dissolution in Amine Oxide: Lyocell

Lyocell is the cellulosic fiber derived from wood pulp solved in a solution of hot *N*-methyl morpholine oxide monohydrate (NMMO·H<sub>2</sub>O) and then spun into fibers. The manufacturing process is designed to recover above 99% of the solvent and the solvent is non-toxic. In this way, lyocell has all the benefits of being a cellulosic fiber that is fully biodegradable, higher strength than cotton and all other man-made staple fibers in both wet and dry state, excellent blending characteristics with fibers such as linen, cashmere, silk and wool. Currently, lyocell is not widely used because of its high cost.

Cotton and rayon are biodegradable fibers widely used in clothing manufacture and other industries. The biodegradability of cellulose fabrics evaluated by soil burial test show that rayon has better biodegradability than cotton (Park, Kang, & Im 2004).

### 1.4.3 Activated Carbon

Activated carbon materials are porous carbonaceous materials, prepared by carbonizing and activating organic substances from mainly biological origin. Research on activated carbon can be dated back to the early 1900s (Smisek & Cerny 1970). Activated carbon materials are ideal for use as high-performance adsorbents and absorbents because of their very high specific surface area and high micropore volume. Granulated charcoal has been a major type of active carbon for many years, because of abundance and low cost of the raw materials.

#### 1.4.3.1 Structure of Activated Carbon

Activated carbon is more or less similar to the structure and properties of graphite. Graphite, one of the two crystalline modifications of pure carbon, is composed of layer planes by carbon atoms in regular hexagons. Figure 4 shows the crystal structure of graphite.

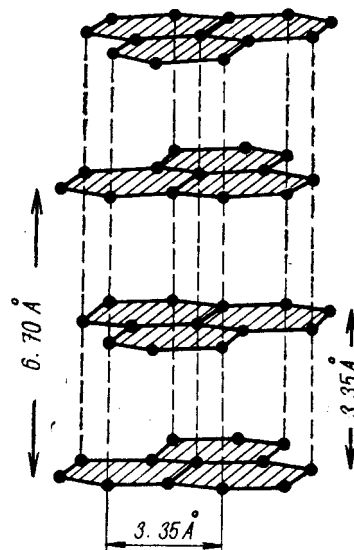

Figure 4 Elementary Graphitic Crystallites (Smisek & Cerny 1970)

The structure of activate carbon is less perfectly ordered than that of graphite. In 1947, Riley proposed two types of structure for active carbons (Riley 1947). The first type of structure consists of elementary crystallites, but the parallel planes are not perfectly oriented with respect

to their common perpendicular axis as graphite. Based on this arrangement, Biscoe and Warren had proposed the term “turbostratic structure” (Biscoe & Warren 1942)., Riley describes a second type of structure as a disordered, cross-linked space lattice of the carbon hexagons.

#### 1.4.3.2 Production of Activated Carbon

Granulated charcoal has been a major type of active carbon produced from a number of materials, in particular, from biomass. Current major fiber precursors for producing commercial ACF fabrics include rayon, acrylic, polyacrylonitrile (PAN), and Novoloid (novolac resin). These raw materials go through a carbonization process in a neutral atmosphere, to remove noncarbonaceous components. Then, an activation process, using gaseous steam or carbon dioxide, increases the pore surface and volume. A material containing more than 99% carbon is thus obtained, with a specific surface area between 1,000 and 2,000m<sup>2</sup>/g determined by the Brunauer-Emmett-Teller (BET) measurements (Subrenat, Baleo, & Le Cloirec 2000).

- Raw Materials

Granulated activated carbon can be produced from a number of materials. The most frequently used precursors are biomass, including peat, forest residue such as wood, bark, sawdust and shavings, and agriculture wastes such as wheat straw, bagasse and coconut shells. It has been proven that any cheap material with high carbon content can be used as raw material for the production of activated carbon (Laine, Calafat, & Labady 1989).

Activated carbon can be impregnated with sulfur, chloride, or iodine to increase its adsorptive capacity. An innovative compositive impregnation process for preparing sulfurized powdered activated carbon (PAC) was developed from waste tires (Yuan et al. 2004).

Current major fiber precursors for producing commercial ACF fabrics include rayon, acrylic, polyacrylonitrile (PAN), and Novoloid (novolac resin). In the past few decades, the raw material for activated carbon fiber was especially focused on viscose rayon, a regenerated

cellulosic fiber commonly used in the nonwovens industry. The process of making rayon requires high quantities of water and energy that produces a negative influence on environment protection and of particular concern is the emission of zinc and hydrogen sulfide. After 1985, the production of rayon decreased dramatically in the U.S. and EU countries. Lyocell is also proposed as a precursor for activated carbon fiber and the structure and properties of lyocell and viscose rayon fibers are compared (Wu & Pan 2002). Cotton is the most popular fiber crop produced in the U.S. Cotton fiber also has a hollow structure that helps increase surface area and porosity. Other natural fibers such as kenaf and hemp with high tensile strength are also regarded as the potential raw materials for ACF. A specialty nonwoven with high performance on chemical absorption and adsorption is expected to be obtained from these fibers.

- Carbonization

The mechanism of carbonizing is a pyrolysis of carbonaceous materials. Pyrolysis is the thermal decomposition of materials in absence of air. During the pyrolysis, hydrogen and oxygen are removed in gaseous form by pyrolytic decomposition and freed carbon atoms are grouped into organized crystallographic forms, i.e., elementary graphitic crystallites (Smisek & Cerny 1970). This lack of planarity, or buckling, prevents a close packing of the structure. The spaces between the buckled layers constitute porosity. The spaces between the layers have dimensions of nanometers and accordingly can be described as micropores with pore size between 0.5 and 2.0 nm.

Most biomass residues are composed of cellulose, hemicellulose, and lignin. When they are heated in an inert atmosphere, they decompose into various pyrolysis products (char, gases, and oils) depending on the operation conditions. The production rate of these pyrolysis products varied in the range of 21.5-47.3% for the char, 31-51.5% for oils, and 11.4-47.5% for gases (Gonzalez et al. 2005). The volatile components of gases mainly have CO<sub>2</sub>, CO, H<sub>2</sub>, CH<sub>4</sub> and

some other volatile gases (Antal & Gronli 2003).

For cellulose, first stages involve the elimination of physically held water, at temperature less than 300°C, with some re-arrangements of structure within the cellulose. Between 240 and 400°C splitting of C-O and C-C bonds occurs with production of tars, water, carbon monoxide and carbon dioxide. Each cellulose molecule is broken down to a residue containing one or more carbon atoms. The critical stage in the pyrolysis is the dehydration followed by growth of the four-carbon systems into defective graphene layers. Slow heating rates, higher heat treatment temperatures and longer soak times favor a more ordered char (Pastor et al. 1999).

Many researchers developed various kinds of kinetic models to describe the complex process of pyrolysis. In the past few decades much work has been done to study the effect of time, temperature, heating rate, pressure and particle size on the gas, liquid and solid yields during the pyrolysis. Low gas flows have more chances to produce more charcoal. Carbonization at elevated pressure can improve the yield of the char from wood particles (Antal & Gronli 2003). More attempts have been made to correlate the pyrolysis characteristics of biomass with the wood constituents of cellulose, hemicellulose, and lignin. Some researchers tried to correlate biomass pyrolysis characteristics with those components using general simple pyrolysis kinetic models. Thermal analysis curves for wood often exhibited three peaks and led researchers to believe that the mechanism of wood pyrolysis was just a superposition of pyrolysis mechanisms of its components (Raveendran, Ganesh, & Khilar 1996). But other researchers refused to correlate the pyrolysis behavior of biomass with that of its components because the structural properties of biomass components influence the pyrolysis. Orfao successfully modeled the pyrolysis of lignocellulosic materials by a kinetic scheme consisting of three independent reactions of three components and found that lignin starts to react at very low temperatures (Orfao, Antunes, & Figueiredo 1999).

Pyrolysis of lignocellulosic materials is complex due to the different reactivities of their constituents. Interactions between constituents and traces of mineral elements present in all biomass residues, which catalyze many reactions that take place during pyrolysis, introduce additional factors of complexity, making it difficult to establish a general model for describing pyrolysis of lignocellulosic residues (Gonzalez, Ramiro, Gonzalez-Garcia, Ganan, Encinar, Sabio, & Rubiales 2005).

After pyrolysis of biomass we get biochar, which is a high heating value solid fuel commonly used in kilns and boilers. Biochar is also considered as a precursor for activation to produce activated carbons. Biochar can be also obtained from selected nitrogen-enriched precursors that have considerable effective surface areas and display good sulfur removal. To this aim, casein was chosen as a biological material with high content of nitrogen (13.4%) for producing activated carbon fibers (Purevsuren et al. 2003).

- Activation

The purpose of activating the carbonized nonwoven is to remove disorganized (amorphous) carbon and to get pure organized (crystalline) carbon. There are two methods for the activation. One type of physical activation is mainly the gasification of non-activated carbon by oxidizing gas such as steam or carbon dioxide to a certain percentage of burn-off. The following reactions occur during the activation (Smisek & Cerny 1970):

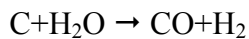
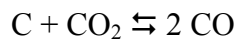

Another is chemical activation that uses activating agents to affect pyrolysis. Chemical activation is carried out by impregnating raw material with an activating agent such as phosphoric acid (Yuan, Lin, Wu, & Liu 2004), zinc chloride or sulfuric acid, followed by carbonization. Recently, potassium salts are used as activating agents. Modification of the

surface of the activated carbon is also possible using oxidizing agents such as nitric acid, ammonium persulphate or  $H_2O_2$ , to create carbon-oxygen groups of different functionalities (El-Hendawy 2005). The pyrolysis of cellulose is always associated first with breaking of polymeric chains. The chemical agents soaked in fibers could increase the production of a solid residue and decrease the volatiles in chemical activation. As a result, higher yields of activated carbons can be obtained in comparison to the physical activation (Huidobro, Pastor, & Rodriguez-Reinoso 2001).

#### 1.4.3.3 Application of Activated Carbon

Activated carbon materials feature exceptional adsorptive, absorptive and desorptive capacity and kinetics, because of their very high specific surface area up to  $2500\text{ m}^2/\text{g}$  and a high micropore volume up to  $1.6\text{ ml/g}$  (Suzuki 1994). Activated carbon materials are ideal for use as high-performance and cost-effective chemical adsorbents and absorbents used widely in industries.

From the invention of activated carbons, manufacture of activated carbon materials was extensively in the form of granule or powder. It was not until the last few decades that activated carbon fibers (ACF) have been developed as a new form of carbon adsorbent. Activated carbon fibers mostly contain easily accessible micropores and macropores exposed to their surfaces, so they have much greater capacity and higher speed in performing adsorption and desorption than powdery and granular activated carbons. Because of its easy-forming property, ACF can be fabricated into cloth, felt and nonwovens to meet the engineering requirements of specific applications.

ACF is presented in the form of traditional textiles composed of multiple threads, so it can be fabricated into cloths and felts to meet engineering requirements. The applications of active carbon cloth include military technology, medical uses, respiratory protection, and odor

and contaminant filters. ACF is particularly effective in shielding the attack of toxic chemical and biological contaminants in the form of gases, liquids, and solid aerosols. Therefore, there has great potential for the military applications. With the help of corrugation and sewing technology, this new type of material can be incorporated into Nuclear, Biological and Chemical (NBC) protective clothing, masks, gloves, and boots. Improved working conditions and protection against atomic, biological and chemical weapons are additional crucial applications. Active carbon filters can be used in museums and galleries for the protection of artworks from contaminant gases, particularly those in hermetically sealed showcases and cabinets. In addition, heat resistance and chemical resistance of the ACF materials are also desirable features for end users.

However, reports are lacking on activated carbon fiber materials for acoustical applications. Noise control has become an important issue for environmental improvement. Different types of acoustical materials are needed for noise reduction in different application sites like office buildings, highways, or manufacturing facilities. Textile fabrics, particularly nonwoven fabrics, have been commonly used for sound absorption, because of a special fabric structural component, mesopores formed by fiber and yarn in the fabrics (Kosuge, Takayasu, & Hori 2005; Lou, Lin, & Su 2005; Shoshani & Yakubov 1999; Shoshani & Yakubov 2000a; Shoshani & Yakubov 2000b; Shoshani 1990; Shoshani & Wilding 1991). In general, dry porous media saturated with air are capable of reducing noise. A theoretical model to describe gas flow traveling in pores has been established (Zwikker & Kosten C.W. 1949). Later, this model was developed to describe acoustic properties of a wide range of porous media (Biot 1956a; Biot 1956b). Further work by Shoshani et al. expanded the Zwikker & Kosten model to predict sound absorption coefficients in the audible frequency band for acrylic, cotton, and polyester fiber webs (Shoshani & Yakubov 1999).

However, nonwovens only had high sound absorption in the high frequency range (above 2000 Hz) in comparison with other fiber materials such as glassfiber and rockwool (Lee & Joo 2003; Lou, Lin, & Su 2005). Lou et al reported that the sound absorption efficiency of nonwoven composites at medium and low frequency levels could be improved by increasing thickness of sound materials. But, this would also increase the size and weight of nonwoven materials (Lou, Lin, & Su 2005).

In general, activated carbon fiber fabrics have two levels of porous structures: macropores among fibers and yarns; and micropores on the surface of activated carbon fiber. This unique fabric architecture renders great potential for the activated carbon fiber fabrics to be used as high-performance and cost effective materials for sound absorption and sound insulation.

#### 1.4.3.4 Porosity in Carbons

Porosity of activated carbons is complex in terms of the size, shape and surface area. To characterize their surface properties, some research has been done by surface chemists in the fifty years.

Microporosity has the dimension of molecules and such molecules, as adsorbate, could be performed as experimental probes to provide significant information. In this way, the phenomena of adsorption and porosity are inseparable. Based on the studies of adsorption, total porosity is classified into three groups. The International Union of Pure and Applied Chemistry (IUPAC) classifies porosities as follows: micropores (diameter less than 2nm), mesopores (diameter between 2 and 50nm) and macropores (diameter greater than 50nm). In the adsorption studies, the experimental isotherms of nitrogen (77K), carbon dioxide (273K) and water vapor provide significant analytical data to describe adsorption capacity, pore size distributions of the porosity, the shapes of the pores, average pore size, the relative position of porosities of different sizes, the surface chemistry of the pore and diffusion paths controlling rates of adsorption.

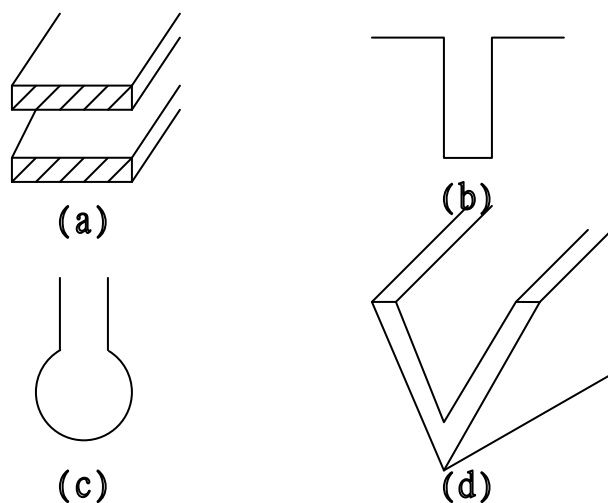

Figure 5 Pore shape models (Patrick 1995)

As indicated in Figure 5, four basic pore models were proposed to classify different pore shapes. These three are: a) slit-shaped pores with parallel plates; b) cylindrical pores, circular in cross section; c) ink-bottle pores having a narrow neck and wide body; and d) Wedge-shaped pores.

- Qualitative Interpretation of Isotherms

Adsorption isotherm is a plot of equilibrium amounts adsorbed ( $\text{mmol g}^{-1}$ ) against the relative pressure,  $p/p^0$  ( $p^0$  = saturation vapor pressure) of the adsorbate at constant pressure. In physical adsorption studies, the adsorption isotherm from experimental adsorption data is important for the evaluation of structural aspects of adsorbents.

A visual inspection of isotherm shapes provides considerable useful information about extents of adsorption and the porous structure. Such isotherms are classified into six shapes that are obtained from adsorption experiments by IUPAC (International Union of Pure and Applied Chemistry) (Figure 6).

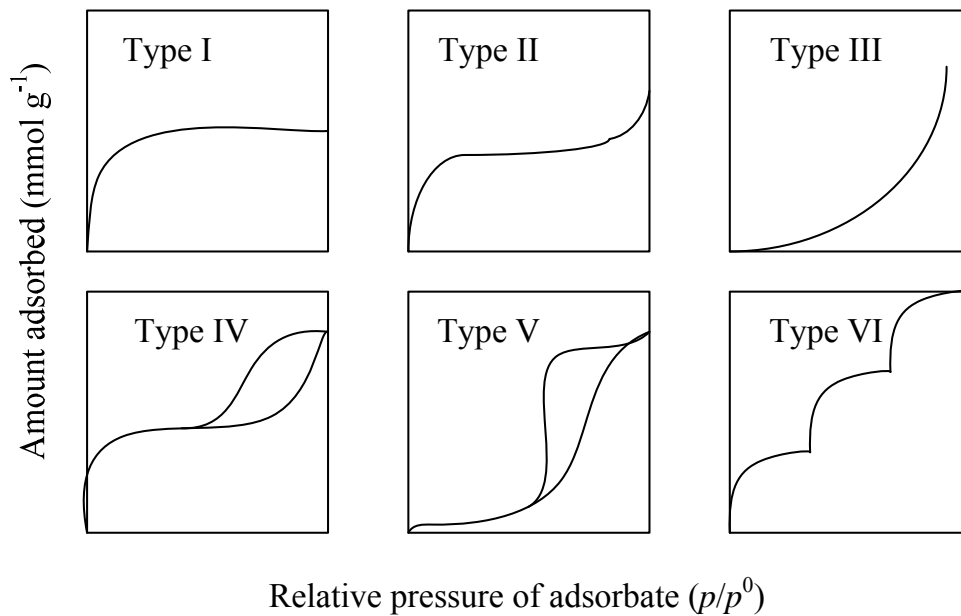

Figure 6 Isotherm shapes (Patrick 1995)

Type I isotherms reach a maximum value at low relative pressures ( $p/p^0 < 0.1$ ). Type II isotherms show at high relative pressure, ( $p/p^0 > 0.9$ ) and adsorption rises very rapidly and happens on open surfaces. Type III isotherms are convex, looking upwards, and characteristic of an increasing capacity of adsorption corresponding to the increase of  $p/p^0$ . Type IV resembles Type II but adsorption takes place in meso-porosity, instead of open surfaces. Such isotherms exhibit a hysteresis loop. Hysteresis loops are associated with meso-porous solids, where capillary condensation occurs. Type V isotherms are those of a low energy, homogeneous solid surface with meso-porosity. Type VI isotherms are stepwise isotherms and represent extremely homogeneous, non-porous surfaces and the step height corresponds to monolayer capacity (Marsh & Rodriguez-Reinoso 2006).

Many mathematical models interpret shapes of isotherms obtained from porous and non-porous solids. Of the three equations available to interpret adsorption isotherms, the Langmuir and Brunauer, Emmett and Teller (BET) equations are based on general models of adsorption.

The Langmuir and BET equations (Patrick 1995) were initially derived for the non-porous carbons. Later, the equations were applied to isotherms derived from microporous materials and they seemed working nicely. On the other hand, the Dubinin-Radushkevich (DR) equation has its roots in the structure of porosities and their distributions of structure.

The Langmuir equation is a plot of amount adsorbed ( $n^a$ ) against  $p/p^0$  and derives the amount of adsorbate that forms a monolayer. The assumptions of Langmuir equation are: (1) Homogeneous surface that means all adsorption sites are identical; (2) Monolayer adsorption (so no multilayer adsorption); and (3) No interaction between adsorbed molecules.

In monolayer adsorption, all the adsorbed molecules are in contact with the surface layer of the adsorbent. While, in multilayer adsorption, the adsorption space accommodates more than one layer of molecules and not all adsorbed molecules are in contact with the surface layer of the adsorbent.

The Langmuir equation is expressed as:

$$\frac{p/p^0}{n^a} = \frac{1}{bn_m^a} + \frac{p/p^0}{n_m^a}, \quad (1)$$

where  $p$  = equilibrium vapor pressure (Pa),  $p^0$  = saturation vapor pressure (Pa),  $n^a$  = amount adsorbed ( $\text{mmol g}^{-1}$ ),  $n_m^a$  = monolayer capacity ( $\text{mmol g}^{-1}$ ).

The surface area  $S$  can be derived from the monolayer capacity  $n_m^a$ .

$$S = n_m^a A_m N, \quad (2)$$

where  $S$  = specific surface area ( $\text{m}^2/\text{g}$ ),  $A_m$  = area occupied by one molecule ( $\text{m}^2/\text{molecule}$ ),  $N$  = Avogadro's number (molecules/mol).

BET equation is the modification of Langmuir equation since it can be applied not only to monolayer adsorption but also to multilayer adsorption. It provides a value of  $n_m^a$  and constant

$c$  describing average energies of adsorption. The value of  $n^m$  can be converted to a surface area provided that the area occupied on the surface by an adsorbed molecule is known. The BET equation fits well for the  $p/p^0 < 0.15$  for microporous carbons. BET equation is expressed as:

$$\frac{p}{V(p^0 - p)} = \frac{1}{V_m c} + \frac{c-1}{V_m c} \times \frac{p}{p^0}, \quad (3)$$

where  $P$  = equilibrium vapor pressure (Pa),  $P^0$  = saturation vapor pressure (Pa),  $V$  = amount adsorbed in volume STP ( $\text{cm}^3 \text{g}^{-1}$ ),  $V_m$  = monolayer capacity in volume STP ( $\text{cm}^3 \text{g}^{-1}$ ),  $c = \exp [(\Delta H_A - \Delta H_L)/RT]$ ,  $\Delta H_A$  = heat of adsorption,  $\Delta H_L$  = heat of liquefaction.

The DR equation differs from the Langmuir and BET equations in that it is based on the considerations of energies of adsorption, as expressed below:

$$W = W_0 \exp[(-BT / \beta)(\log^2(p^0 / p))], \quad (4)$$

where  $W$  = volume of adsorbate filling micropores ( $\text{cm}^3 \text{g}^{-1}$ ),  $W_0$  = total volume of the micropores ( $\text{cm}^3 \text{g}^{-1}$ ),  $p^0$  = saturation vapor pressure,  $\beta$  = adsorbate affinity coefficient; and  $B$  = constant related to the adsorption potential of the micropores (Marsh & Rodriguez-Reinoso 2006; Patrick 1995; Smisek & Cerny 1970).

A big difference between BET surface area and median pore width of  $\text{N}_2$  and  $\text{CO}_2$  adsorption could be seen on the same adsorbent. We know that the size of the two molecules is very similar (0.28 nm for  $\text{CO}_2$  and 0.30 nm for  $\text{N}_2$ ) and the both adsorbates are expected to lead to the same value of the BET surface area and pore size. However, the lower values of surface area of  $\text{N}_2$  adsorption were observed. This could be understood as the effects of the activated diffusion (Harry & Francisco 2006). As the low activation energy in the chemical reactions, rates of the adsorption process decrease dramatically with the decreasing temperature.  $\text{N}_2$  adsorption performed at 77 K makes  $\text{N}_2$  molecules unable to diffuse through micropores, while  $\text{CO}_2$

molecules at 273 K are easily to access to the narrow micropores. Moreover, if the entry of the micropores is too narrow, the diffusion time of N<sub>2</sub> at 77 K may be too long to allow equilibrium within a reasonable experimental time (Garrido et al. 1987). An increase in adsorption temperature of CO<sub>2</sub> adsorption at 273 K compared with N<sub>2</sub> at 77 K leads to an increase in the diffusion rate of the molecules into the micropores and to an increase of the adsorbed amount. The combination of adsorption isotherms of N<sub>2</sub> and CO<sub>2</sub> are recommended because the isotherms for both N<sub>2</sub> and CO<sub>2</sub> could provide complementary information in terms of micro-porosity, meso-porosity and macro-porosity in activated carbons.

## **1.5 Methodology**

### **1.5.1 Experiment**

#### **1.5.1.1 Nonwoven Fabrication**

Raw natural fibers were fed into a Universal Laboratory Carding Machine (F015D) (Figure 7) to obtain a fiber web. During the carding, the fiber blends are further opened and individual fibers are combed to be relatively parallel. To enhance web uniformity, the fiber blend can be carded twice.



Figure 7 Carding Machine



Figure 8 Needle Punching Machine

A Morisson Benkshire needle-punching machine (Figure 8) was used for mechanically bonding the web. It runs at a feeding speed of 5.4 feet/min and punching rate of 228 strokes/min. The fiber web was significantly compacted after needle-punching. The needle-punched cotton nonwoven fiber was then obtained and ready for carbonization. The whole nonwoven procedure is shown in Figure 9.

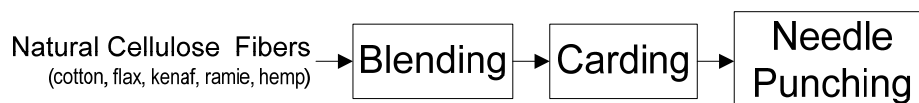

Figure 9 Nonwoven Processing

#### 1.5.1.2 Carbonization and Activation

The carbonization was carried out in a clear room oven HCR (Carbolite Co.) (Figure 10) purged with nitrogen with a heating rate of 20°C/min. The activation of the carbonized nonwovens was undertaken using CO<sub>2</sub>. The highest temperature for carbonization and activation were in range of 300-500°C. Holding time for these two steps was ranging from 20 minutes to 1

hour (obtaining 75% weight loss) (Figure 11). Total weight loss of the carbonized and activated nonwoven was around 80%.



Figure 10 Clean Room Oven

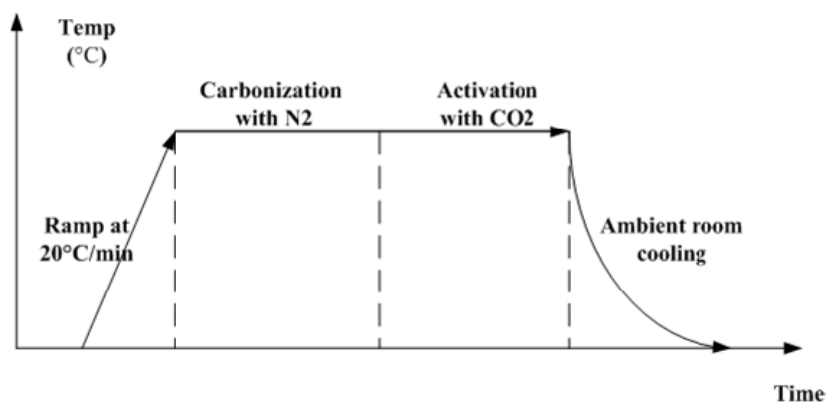

Figure 11 Carbonization and Activation Procedures

Carbonization and activation steps were carried out in the glass tube in the ASAP 2020 instrument (Figure 12) under a flow of nitrogen and CO<sub>2</sub> to different final temperatures range from 600 to 900°C. The vertical glass tube could obtain high vacuum, thus in carbonization and activation steps the air (oxygen) was excluded. The ASAP instrument could also control temperature more accurately than the oven described in Figure 10.

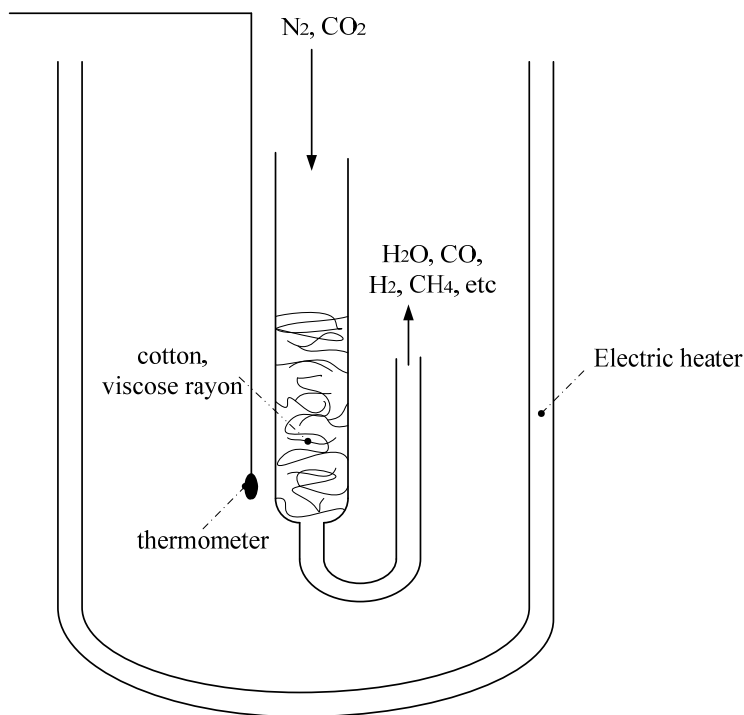

Figure 12 Carbonization and Activation Instrument (ASAP 2020)

## 1.5.2 Evaluation

A series of instrumental measurements was carried out for the activated carbon nonwovens in terms of microstructures, mechanical properties, chemical adsorption, flame resistance, and sound absorption and insulation. Characterization of these important properties provided understanding of structural changes in the carbon fiber nonwovens before and after the carbonization and activation; found effective ways to optimize the process; and explored new approaches for end-use applications of the activated carbon nonwovens.

### 1.5.2.1 Mechanical Properties

The activated carbon nonwovens are very bulky and floppy. Their responses to external loads are strongly non-linear. Classical mechanics for elastica is not practical for these limp materials. The evaluation of mechanical properties of the activated carbon nonwovens can only rely on empirical approaches.

To examine the strength reduction of the nonwoven after carbonization and activation, tensile strength of surface cotton nonwoven and ACF nonwoven was measured using an Instron in both along and cross machine directions in accordance with American Society for Testing and Materials (ASTM D 5035). The sample gauge length was 7.5 cm and the sample width is 2.5 cm.

#### 1.5.2.2 Thermal Properties

The thermogravimetric analysis (TGA) is an instrumental method to determine changes in weight in relation to change in temperature of the sample. The thermal degradation of the nonwoven samples was tested using the instrument 2950 TGA HR (TA Instruments Inc., USA) between the room temperature and 600°C. The experiment was carried out with a 5 mg sample in N<sub>2</sub> flow.

#### 1.5.2.3 Scanning Electron Microscope (SEM) Test

The surface structures of activated carbon fibers are very important because the absorption capacity highly depends on the pore volume and size. Comparisons of the adsorbent properties of these activated carbon materials indicate that activated carbon fibers are markedly different in terms of porosity from those made from activated carbon granules or power. Therefore, the surface structure of activated carbon fiber fabrics has become an increasingly important area of research and the focus of much attention (Jayson et al. 1993). In this research, the microstructure and surface texture were investigated using a technique of Scanning Electronic Microscopy (SEM) of 3-D images. Surface and cross-sectional structure of the carbonized and activated fiber was examined under the SEM Hitachi S-3600N. Changes of the fiber micro structure are evaluated in comparison with an original image of the raw fiber.

#### 1.5.2.4 Porosity and Surface Area

Porous characteristics of the carbonized and activated nonwovens were evaluated by adsorption isotherms that were determined by the adsorption process related to the equilibrium

partial pressure at constant temperature. The properties of surface area, pore volumes and pore-size distribution were obtained by interpreting isotherms through some mathematical models. In this study, the Brunauer, Emmett and Teller (BET) equation (Brunauer, Emmett, & Teller 1938) was specially used for multilayer adsorption using nitrogen at 77K or CO<sub>2</sub> at 273K.

A physisorption analyzer ASAP 2020 (Micromeritics Inc.) (Figure 13) was used to perform a gas adsorption by adding a known volume of gas (adsorbate) to the nonwoven sample in a sample tube at a cryogenic temperature. At the cryogenic temperature, weak molecular attractive forces drive gas molecules to be adsorbed onto the nonwoven fiber surface. Because the relationship between the gas pressure and gas volume inside the tube was known, the volume of gas adsorbed by the sample was determined by measuring the reduced pressure due to the gas adsorption.



Figure 13 Physisorption Analyzer

In this study, the sample was degassed first and then analyzed using N<sub>2</sub> or CO<sub>2</sub> to determine the adsorption and desorption isotherm curves of the carbonized and activated cotton nonwovens. Based on the measured isotherm data, the sample surface area was calculated by the

BET method and the sample pore size was determined by the the evaluation of micropore volume was based on a t-plot model and the average pore size was calculated according to the notable Barrett, Joyner and Halenda (BJH) model (Barrett, Joyner, & Halenda 1951).

#### 1.5.2.5 Acoustical Properties

- Measurement of Sound Absorption

The measurement of sound absorption of the nonwovens was based on the method of ASTM E 1050: Standard Test Method for Impedance and Absorption of Acoustical Properties Using a Tube, Two Microphones and a Digital Frequency Analysis System. This method was developed to determine the ability of materials for absorbing normal incidence sound waves. A Brüel & Kjær measuring instrument is used for testing within the frequency range 0 – 6.4 kHz. This instrument includes Type 4206 Impedance Tube, PULSE Analyzer Type 3560, and Type 7758 Material Test Software. The testing principle of this system is illustrated in Figure 14.

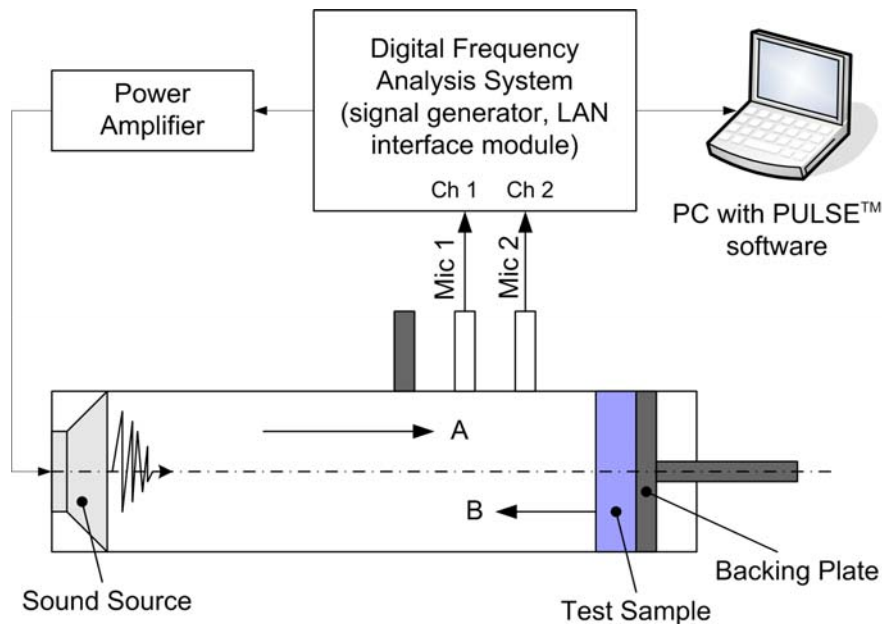

Figure 14 Sound Adsorption Measuring System Configuration

A sound source was mounted at one end of the impedance tube and the material sample was placed at the other end. The loudspeaker generates broadband, stationary random sound

waves. These incident sound signals propagated as plane waves in the tube and hit the sample surface. The reflected wave signals were picked up and compared to the incident sound wave. The sound frequency range to be tested depended on the diameter of the tube. A large tube (100 mm diameter) was set up for measuring the nonwoven sound absorption in the low frequency range from 50 Hz to 1600 Hz. A small tube (29 mm diameter) was set up for testing the material sound absorption in the high frequency range of 500 Hz – 6400 Hz. Three specimens were tested for each type of the experimental acoustic nonwoven composites.

- Measurement of Sound Insulation

Sound transmission loss (TL) represents the loss in sound power during sound transmission through a specimen. The higher the transmission loss, the less the sound waves pass through the specimen. The TL tests were divided into two parts. In the first stage no sample was placed between the impedance tubes. In this case, the results should be 100% transmission and 0% reflection. In the second stage the sample was put between the noise source tube and receiving tube. The incident noise waves hit the sample and were divided into three parts: reflected waves, absorbed waves, and transmitted waves (Figure 15).

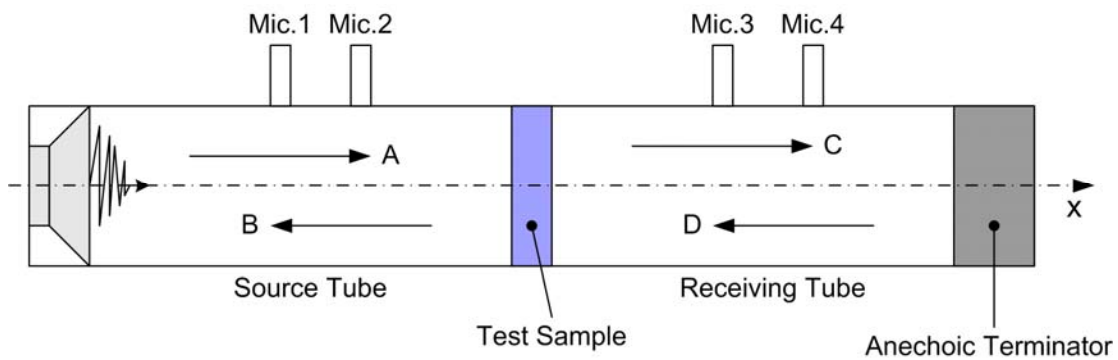

Figure 15 Sound Transmission Loss Measurement System

By measuring the sound pressure at the four microphone locations 1, 2, 3, and 4, transmission loss of the material was determined. The Brüel & Kjær instrument for testing

normal incidence sound transmission loss was used for this evaluation. The instrumental set up included four microphones and two tubes discussed above (large tube for measuring sound frequencies within 100-1600 Hz; small tube for measuring sound frequencies within 1600-6400 Hz).

## 1.6 References

Antal, M. J. & Gronli, M. 2003, "The art, science, and technology of charcoal production", *Industrial & Engineering Chemistry Research*, vol. 42, no. 8, pp. 1619-1640.

Barrett, E. P., Joyner, L. G., & Halenda, P. P. 1951, "The Determination of Pore Volume and Area Distributions in Porous Substances .1. Computations from Nitrogen Isotherms", *Journal of the American Chemical Society*, vol. 73, no. 1, pp. 373-380.

Biot, M. A. 1956a, "Theory of Propagation of Elastic Waves in A Fluid-Saturated Porous Solid .1. Low-Frequency Range", *Journal of the Acoustical Society of America*, vol. 28, no. 2, pp. 168-178.

Biot, M. A. 1956b, "Theory of Propagation of Elastic Waves in A Fluid-Saturated Porous Solid .2. Higher Frequency Range", *Journal of the Acoustical Society of America*, vol. 28, no. 2, pp. 179-191.

Biscoe, J. & Warren, B. E. 1942, "An X-ray study of carbon black", *Journal of Applied Physics*, vol. 13, no. 6, pp. 364-371.

Brunauer, S., Emmett, P. H., & Teller, E. 1938, "Adsorption of gases in multimolecular layers", *Journal of the American Chemical Society*, vol. 60, pp. 309-319.

Butler, L. 2008, "Growth Prospects for the Nonwovens Industry Worldwide ", *International Nonwovens Technical Conference*.

Chaplin, M. 2008, "Cellulose", <http://www.lsbu.ac.uk/water/hycel.html>.

Chen, Y., Sun, L. F., Chiparus, O., Negulescu, I., Yachmenev, V., & Warnock, M. 2005, "Kenaf/ramie composite for automotive headliner", *Journal of Polymers and the Environment*, vol. 13, no. 2, pp. 107-114.

Collier, B. J. & Tortora, P. G. 2001, *Understanding Textiles*, 6 edn, Prentice Hall, Upper Saddle River, New Jersey.

deGruy, I. V., Carra, J. H., Goynes, W. R., & O'Connor, R. T. 1973, *The Fine Structure of Cotton* Marcel Dekker, INC., New York.

EDANA 2008, "European Disposables and Nonwovens Association", <http://www.edana.org/content/default.asp?PageID=33>.

- El-Hendawy, A. N. A. 2005, "Surface and adsorptive properties of carbons prepared from biomass", *Applied Surface Science*, vol. 252, no. 2, pp. 287-295.
- Garrido, J., Linaressolano, A., Martinmartinez, J. M., Molinasabio, M., Rodriguezreinoso, F., & Torregrosa, R. 1987, "Use of N<sub>2</sub> Vs Co<sub>2</sub> in the Characterization of Activated Carbons", *Langmuir*, vol. 3, no. 1, pp. 76-81.
- Gillies, M. T. 1979, *Nonwoven Materials* Noyes Data Corporation, Park Ridge, New Jersey.
- Gonzalez, J. F., Ramiro, A., Gonzalez-Garcia, C. M., Ganan, J., Encinar, J. M., Sabio, E., & Rubiales, J. 2005, "Pyrolysis of almond shells. Energy applications of fractions", *Industrial & Engineering Chemistry Research*, vol. 44, no. 9, pp. 3003-3012.
- Harry, M. & Francisco, R. R. 2006, *Activated Carbon*, 1 edn, Elsevier, United Kindom.
- Huidobro, A., Pastor, A. C., & Rodriguez-Reinoso, F. 2001, "Preparation of activated carbon cloth from viscous rayon - Part IV. Chemical activation", *Carbon*, vol. 39, no. 3, pp. 389-398.
- INDA 2008, "North America's Association of the Nonwoven Fabrics Industry", [http://www.inda.org/category/nwn\\_index.html](http://www.inda.org/category/nwn_index.html).
- Jayson, G. G., Sangster, J. A., Thompson, G., & Wilkinson, M. C. 1993, "Adsorption of Chromium from Aqueous-Solution Onto Activated-Charcoal Cloth", *Carbon*, vol. 31, no. 3, pp. 487-492.
- Kosuge, K., Takayasu, A., & Hori, T. 2005, "Recyclable flame retardant nonwoven for sound absorption; RUBA (R)", *Journal of Materials Science*, vol. 40, no. 20, pp. 5399-5405.
- Laine, J., Calafat, A., & Labady, M. 1989, "Preparation and Characterization of Activated Carbons from Coconut Shell Impregnated with Phosphoric-Acid", *Carbon*, vol. 27, no. 2, pp. 191-195.
- Lee, Y. & Joo, C. 2003, "Sound absorption properties of recycled polyester fibrous assembly absorbers", *AUTEX Research Journal*, vol. 3, no. 2, pp. 78-84.
- Lou, C. W., Lin, J. H., & Su, K. H. 2005, "Recycling polyester and polypropylene nonwoven selvages to produce functional sound absorption composites", *Textile Research Journal*, vol. 75, no. 5, pp. 390-394.
- Marsh, H. & Rodriguez-Reinoso, F. 2006, *Activated Carbon* Elsevier Publishing Company, New York.
- McIntyre, K. B. 2008, "Top ten nonwovens manufactures", *International Nonwovens Technical Conference*.
- O'Regon, J. 2008, "Global Cotton Outlook", *International Nonwovens Technical Conference*.
- Orfao, J. J. M., Antunes, F. J. A., & Figueiredo, J. L. 1999, "Pyrolysis kinetics of lignocellulosic materials - three independent reactions model", *Fuel*, vol. 78, no. 3, pp. 349-358.

- Palexpo, G. 2005, "Nonwovens in filtration - INDEX05", *Filtration & Separation*, vol. 42, no. 2, pp. 26-29.
- Park, C. H., Kang, Y. K., & Im, S. S. 2004, "Biodegradability of cellulose fabrics", *Journal of Applied Polymer Science*, vol. 94, no. 1, pp. 248-253.
- Pastor, A. C., Rodriguez-Reinoso, F., Marsh, H., & Martinez, M. A. 1999, "Preparation of activated carbon cloths from viscous rayon. Part I. Carbonization procedures", *Carbon*, vol. 37, no. 8, pp. 1275-1283.
- Patrick, J. W. 1995, *Porosity in Carbons* John Wiley & Sons, Inc., New York.
- Purevsuren, B., Avid, B., Tesche, B., & Davaajav, Y. 2003, "A biochar from casein and its properties", *Journal of Materials Science*, vol. 38, no. 11, pp. 2347-2351.
- Raveendran, K., Ganesh, A., & Khilar, K. C. 1996, "Pyrolysis characteristics of biomass and biomass components", *Fuel*, vol. 75, no. 8, pp. 987-998.
- Riley, H. L. 1947, "Amorphous Carbon and Graphite", *Quarterly Reviews*, vol. 1, no. 1, pp. 59-72.
- Russell, S. J. 2007, *Handbook of nonwovens*, 1 edn, Woodhead Publishing Limited, Cambridge.
- Shoshani, Y. & Yakubov, Y. 1999, "A model for calculating the noise absorption capacity of nonwoven fiber webs", *Textile Research Journal*, vol. 69, no. 7, pp. 519-526.
- Shoshani, Y. & Yakubov, Y. 2000a, "Generalization of Zwicker and Kosten theory for sound absorption in flexible porous media to the case of variable parameters", *Journal of Computational Acoustics*, vol. 8, no. 3, pp. 415-441.
- Shoshani, Y. & Yakubov, Y. 2000b, "Numerical assessment of maximal absorption coefficients for nonwoven fiberwebs", *Applied Acoustics*, vol. 59, no. 1, pp. 77-87.
- Shoshani, Y. Z. 1990, "Effect of Nonwoven Backings on the Noise Absorption Capacity of Tufted Carpets", *Textile Research Journal*, vol. 60, no. 8, pp. 452-456.
- Shoshani, Y. Z. & Wilding, M. A. 1991, "Effect of Pile Parameters on the Noise Absorption Capacity of Tufted Carpets", *Textile Research Journal*, vol. 61, no. 12, pp. 736-742.
- Smisek, M. & Cerny, S. 1970, *Active Carbon - Manufacture, Properties and Applications* Elsevier Publishing Company, New York.
- Subrenat, A., Baleo, J. N., & Le Cloirec, P. 2000, "Analysis of pressure drops in pleated activated carbon cloth filters", *Journal of Environmental Engineering-Asce*, vol. 126, no. 6, pp. 562-568.
- Suzuki, M. 1994, "Activated carbon fiber: fundamental and applications", *Carbon*, vol. 32, no. 2, pp. 577-586.

Woodings, C. 2001, *Regenerated Cellulose Fibers* Woodhead Publishing Limited, Cambridge, England.

Wu, Q. L. & Pan, D. 2002, "A new cellulose based carbon fiber from a lyocell precursor", *Textile Research Journal*, vol. 72, no. 5, pp. 405-410.

Yuan, C. S., Lin, H. Y., Wu, C. H., & Liu, M. H. 2004, "Preparation of sulfurized powdered activated carbon from waste tires using an innovative compositive impregnation process", *Journal of the Air & Waste Management Association*, vol. 54, no. 7, pp. 862-870.

Zwikker, C. & Kosten C.W. 1949, *Sound absorbing material* Elsevier, Amsterdam.

## **Chapter 2 Preparation and Surface Characterization of Fibrous Activated Carbon from Cotton Nonwoven**

### **2.1 Introduction**

Activated carbons are microporous carbonaceous materials mainly prepared by carbonizing and activating organic substances of biological origin, such as wood, coal, coconut shells, banana pitch and corncobs (Kadirvelu et al. 2003). Research on active carbon can be dated back to the early 1900s (Smisek & Cerny 1970), when the manufacture of activated carbon materials was extensively focused on granulated charcoals only. A method to produce carbonaceous fibers by carbonizing and activating cellulosic fibers was reported in the 1960s (Bacon & Tang 1964; Tang & Bacon 1964). Since then, increasing attention has been drawn to the studies on the use of fibers and fabric assemblies as raw materials for carbonization.

Current major fiber precursors for producing commercial activated carbon fibers (ACF) and fabrics include viscose rayon (Huidobro, Pastor, & Rodriguez-Reinoso 2001b), acrylic , polyacrylonitrile (PAN) (Ko, Chiranairadul, & Lin 1991), and Novoloid (novolac resin), lyocell (Wu & Pan 2002). This paper focuses on carbonizing and activating a cotton nonwoven fabric. Cotton is the most popular fiber crop produced in the U.S. Cotton fiber also has a hollow structure that helps increase surface area and porosity. Thus, a specialty cotton nonwoven with high performance on chemical absorption and adsorption could be obtained. Iwasaki *et al* investigated preparation of carbonaceous adsorbent from cotton waste and its application to remove chemicals in water (Iwasaki et al. 2001). Carbon monolith prepared from a 75:25 mixture of phenol resin and cotton fiber showed high methane adsorption capacity (Muto et al. 2005). Use of ACF for nonwoven production would be expected to greatly enhance nonwoven performance and to expand end-use applications including military protective clothing, solvent recovery, wastewater treatment, water purification, air cleaning, acoustic insulation in

automobiles (Chen & Jiang 2007) and other specialty nonwoven uses. In this paper, the activated carbon fibers obtained from cotton nonwoven are quantitatively characterized in terms of their porous structure (specific surface area, pore volume and pore size) by surface area analyzer. The microstructure and surface texture are investigated with the aid of an image technique. The purpose of this study is to find a feasible approach for carbonizing and activating cotton nonwovens, and to instrumentally evaluate adsorptive performance of the cotton nonwovens after carbonization and activation.

## **2.2 Experimental**

### **2.2.1 Nonwoven Fabrication**

Cotton fibers were first fed into a carding machine (Figure 7) to obtain a fiber web. A needle-punching machine (Figure 8) was used for mechanically bonding the web. The needle-punched cotton nonwoven was then obtained and ready for carbonization.

### **2.2.2 Carbonization and Activation**

The carbonization was carried out in a clear room oven HCR (Carbolite Co.) (Figure 10) purged with nitrogen and heating rate was 20°C/min. The activation of the carbonized nonwovens was undertaken using CO<sub>2</sub>. Highest temperature for carbonization and activation was 300-500°C. Holding time for these two steps was 30 mins.

## **2.3 Results and Discussion**

### **2.3.1 Pore Characteristics**

After carbonization the samples were degassed for 2 hours at 250°C and then subjected to analysis of the adsorption isotherm of Nitrogen at 77 K. The isotherm curves of various temperatures shown in Figure 2 indicate that for carbonized cotton nonwoven at 300°C, 350°C, 400°C and 450°C these curves are similar to a combination of Type I and II isotherms (Harry & Francisco 2006). Type I isotherm reaches a maximum value of adsorption from  $p/p^0$  values from

to zero to about 0.05, while type II isotherm describes adsorption at the high relative pressure region  $p/p^0 > 0.9$ .

In Figure 16, at low relative pressures, all the isotherms appear to be Type I in shape, demonstrating the presence of micropores since Type I isotherms are typical properties of microporous solids when micropores are filled at relatively low partial pressures. With the relative pressure approaching 1, the curves closed to Type II shape show the presence of macropores. An increase of capacity for adsorbing  $N_2$  with the increased carbonization temperature can also be observed since the carbonized cotton nonwoven with higher treatment temperature tends to have higher amount of absorbed nitrogen.

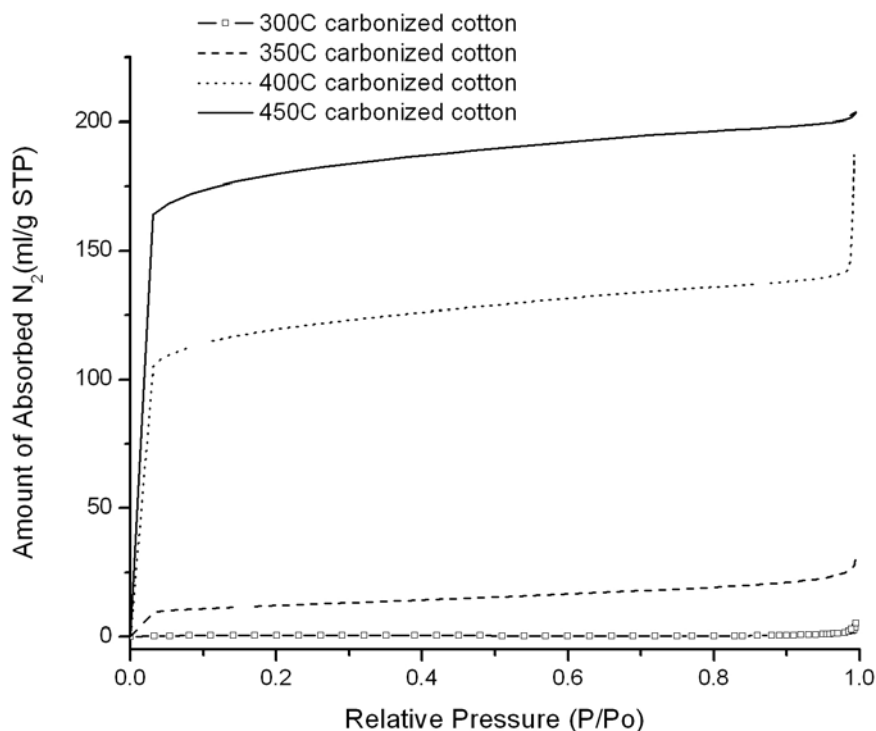

Figure 16 Adsorption Isotherms of  $N_2$  at 77K at various carbonization Temperatures

The BET surface area, pore volume and average pore diameter of cotton nonwoven carbonized at different temperature is summarized in Table 1. With the increase of carbonization

temperature from 300°C to 450°C, BET surface areas of carbonized cotton nonwoven increase from 1.97 m<sup>2</sup>/g to 557 m<sup>2</sup>/g. Total pore volume and micropore volume are also increased significantly. The percentage of micropore volume indicates that when carbonization temperature increases to 450°C, the pores in the cotton nonwoven are occupied by micropores, which is also confirmed by the Type I shape of the isotherm curves in Figure 16. Pore size is decreasing with the increasing carbonized temperature and BJH Average Pore Diameter of cotton carbonized at 450°C is 2.88 nm which is close to micropore size (< 2 nm). The adsorption isotherm and surface porous data are both demonstrating that the effect of carbonization treatment temperature of cotton nonwoven fiber are significant and the higher the carbonization temperature, the better the adsorption properties. High temperature seems to improve the development of porosity. When the process was performed at 500°C, cotton nonwoven web could not maintain its original architecture because of the weakness of the carbonized fibers endured after higher temperature.

Table 1 Surface Area, Pore Volume and Pore Diameter

Nonwoven Sample	BET Surface Area (m <sup>2</sup> /g)	Total Pore Volume (cm <sup>3</sup> /g)	t-Plot Micropore Volume (cm <sup>3</sup> /g)	Percentage of Micropore Volume (%)	BJH Average Pore Diameter (nm)
Raw Cotton	0.82	0.0011	0.000048	4.4	70.86
Carbonized at 300°C	1.97	0.0048	0.000058	1.2	8.76
Carbonized at 350°C	40.48	0.044	0.0067	15.2	4.76
Carbonized at 400°C	375	0.28	0.13	46.4	3.22
Carbonized at 450°C	557	0.31	0.22	71.0	2.88

Table 2 exhibits the comparison between the adsorption of nitrogen at low temperature (77 K) and the adsorption of carbon dioxide at a higher temperature (273 K) for the Carbonized Cotton and Carbonized+Activated Cotton processed at 350°C. The results from both N<sub>2</sub> and CO<sub>2</sub> adsorption show that the cotton nonwoven after carbonization and activation has higher BET

surface area than cotton nonwoven with carbonization only. Pore size is increased after the CO<sub>2</sub> physical activation. This may be explained by the fact that the activation not only forms the pores but also widens the size of existing pores according to the reaction  $C + CO_2 \rightarrow 2CO$  (Huidobro, Pastor, & Rodriguez-Reinoso 2001a).

Table 2 Comparison of N<sub>2</sub> and CO<sub>2</sub> Adsorption

Nonwoven Sample	BET Surface Area (m <sup>2</sup> /g)		Median Pore Width (nm)	
	N <sub>2</sub>	CO <sub>2</sub>	N <sub>2</sub>	CO <sub>2</sub>
Carbonized Cotton	40.48	455	4.76	0.6282
Carbonized+Activated Cotton	49.90	479	9.79	0.6339

Big differences between BET surface area and median pore width of N<sub>2</sub> and CO<sub>2</sub> adsorption could be seen on the same adsorbent. We know that the size of the two molecules is very similar (0.28 nm for CO<sub>2</sub> and 0.30 nm for N<sub>2</sub>) and both adsorbates are expected to lead to the same value of the BET surface area and pore size for the same sample. However, the lower values of surface area of N<sub>2</sub> adsorption are now understood to be due to the activated diffusion effects (Harry & Francisco 2006). As the low activation energy in the chemical reactions, rates of the adsorption process decrease dramatically with the decreasing temperature. N<sub>2</sub> adsorption performed at 77 K makes N<sub>2</sub> molecular unable to diffuse through micropores, while CO<sub>2</sub> molecular at 273 K are easy to access to the narrow micropores. Moreover, if the entry of the micropores is too narrow, the diffusion time of N<sub>2</sub> at 77 K may be too long to allow equilibrium within a reasonable experimental time (Garrido et al. 1987). An increase in adsorption temperature of CO<sub>2</sub> adsorption at 273 K compared with N<sub>2</sub> at 77 K leads to an increase in the diffusion rate of the molecules into the micropores and to an increase of the adsorbed amount. In this way, BET surface area for N<sub>2</sub> adsorption is much smaller than that for CO<sub>2</sub> adsorption. Since N<sub>2</sub> is mainly adsorbed in the larger micropores and on the non microporous surface, median pore width for the N<sub>2</sub> adsorption is greater than that for CO<sub>2</sub> adsorption. The combination of

adsorption isotherms of N<sub>2</sub> and CO<sub>2</sub> are recommended and the isotherms could provide complementary information in terms of micro-porosity, meso-porosity and macro-porosity in activated carbons.

### 2.3.2 Fabric Tensile Strength

The data listed in Table 3 are average tensile strength for the activated carbon cotton nonwoven. After the carbonization and activation at 350°C for 20 minutes, the breaking strength of the cotton nonwoven dropped from 16.6 N to 1.3 N on along machine direction and from 33 N to 1.4 N on cross machine direction. This pyrolytic degradation occurs during the carbonization and activation. High temperature causes the C-O and C-C bonds to split in cellulose, and as a result, tars, water, carbon monoxide, and carbon dioxide, methane and some other liquids are produced.

Although tensile strength of the cotton fiber nonwovens is reduced significantly due to the high temperature damage during carbonization and activation, the ACF nonwoven still kept a good web form.

Table 3 Tensile strength of Nonwoven Fabrics

Nonwoven Type	Break Strength (N)		Elongation at Break (%)	
	Along machine	Cross machine	Along machine	Cross-machine
Cotton	16.6	33.0	45	48
ACF Cotton	1.3	1.4	10	23

### 2.3.3 SEM Images

The SEM photomicrographs in Figure 17-19 exhibit a development of porous areas on the cotton fiber surface after the carbonization and activation at 350°C. It can also be observed in Figure 18 that the cotton inner hollow was enlarged after carbonization and small pores appeared on the surface. In Figure 19, after activation overall porosity of the cotton nonwoven would be further increased. Wrinkles showed up on the surface after activation because of cotton shrinkage.

From these SEM pictures, conclusion can be drawn that surface areas of fibers are increased after carbonization and activation compared with raw cotton fibers.

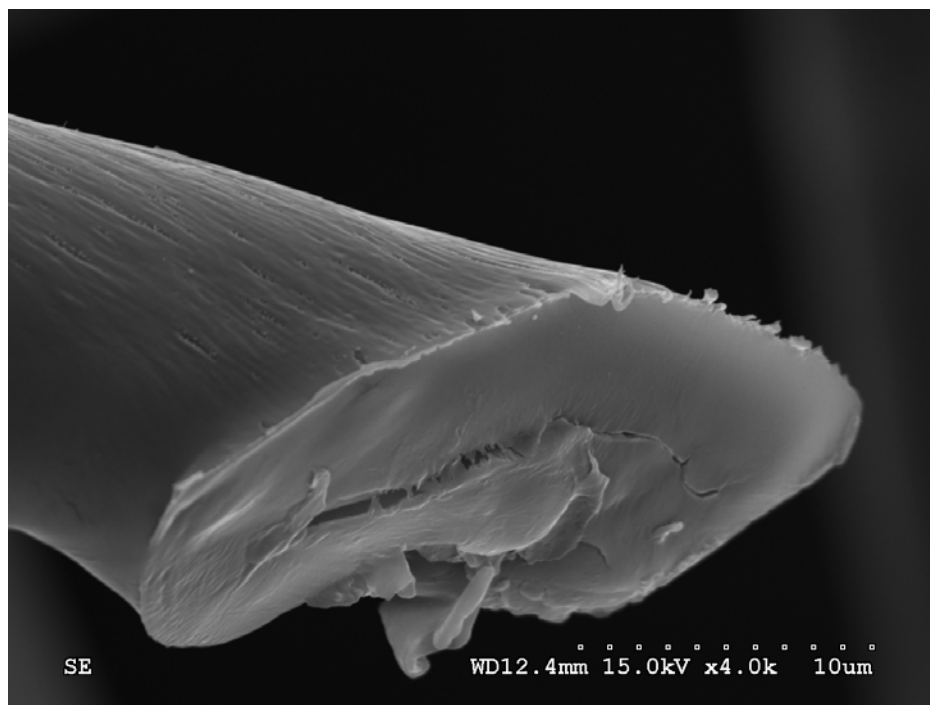

Figure 17 Raw Cotton

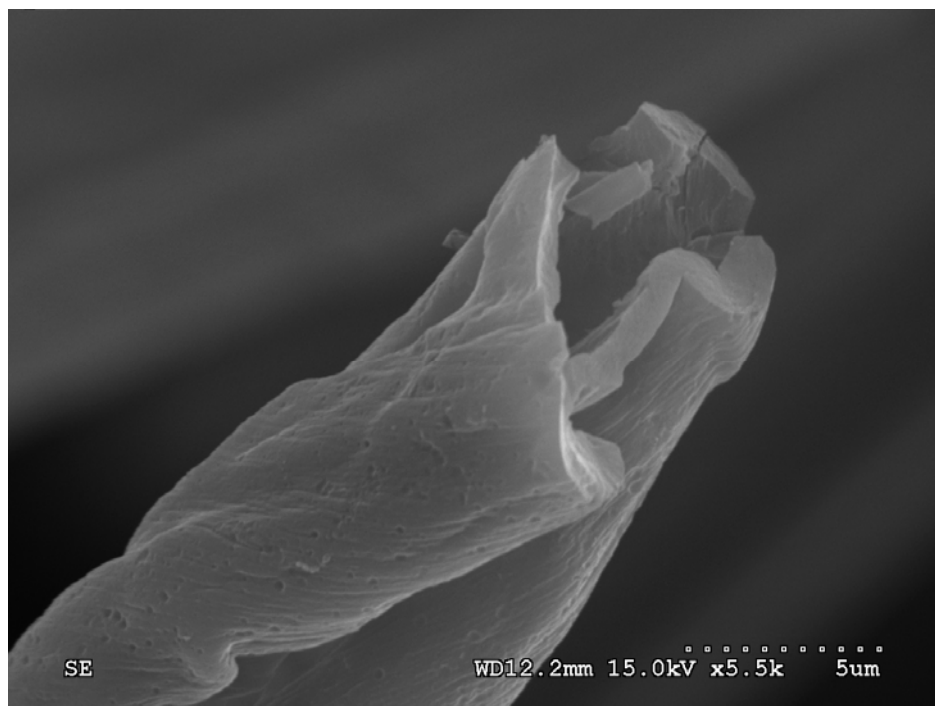

Figure 18 Carbonized Cotton

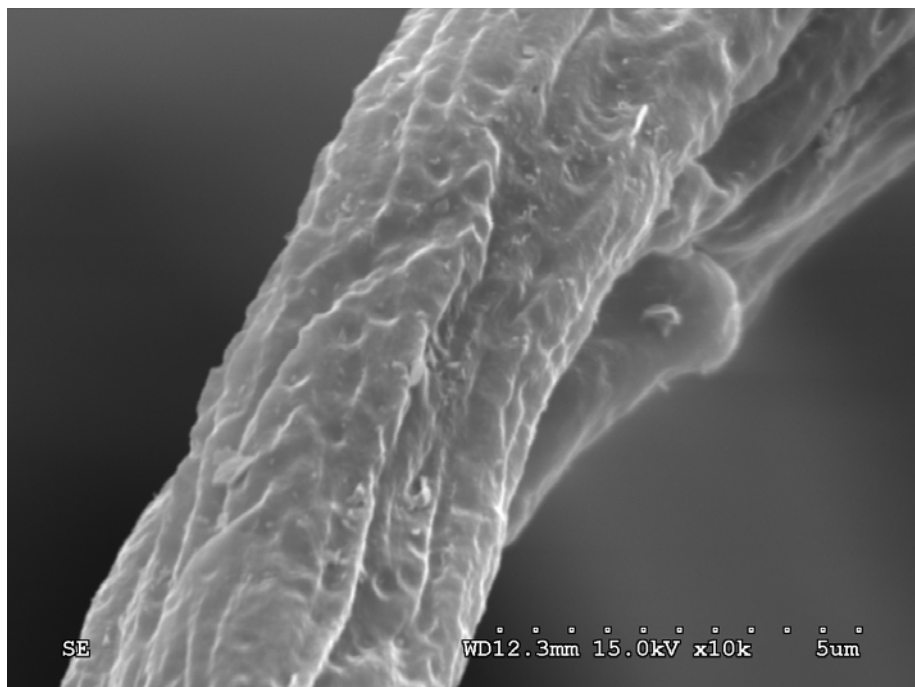

Figure 19 Carbonized and Activated Cotton

## 2.4 Conclusion

Cotton nonwoven could be a good precursor for producing activated carbon materials used as high-performance adsorbents and absorbents because of their high specific surface area and a high micropore volume. The approach of carbonization and activation used in this study helped pure cotton nonwovens develop microporous structures. The  $N_2$  adsorption isotherm curves of the cotton nonwoven under different carbonization temperature showed the presence of micropores and macropores. The surface area of the cotton nonwoven after the carbonization and activation was increased from  $0.82 \text{ m}^2/\text{g}$  to  $557 \text{ m}^2/\text{g}$ . The average micro pore diameters were distributed in the range of 2.88 to 8.76 nm with different carbonization treatment temperatures. High treatment temperature tended to improve the development of porosity. The comparison between the  $N_2$  and  $CO_2$  adsorption showed that BET surface area for  $N_2$  adsorption is much smaller than that for  $CO_2$  adsorption and median pore width for the  $N_2$  adsorption is greater than that for  $CO_2$  adsorption due to the activated diffusion effects. Under the present experimental

setting, the process of activation had little influence on further increasing the cotton nonwoven surface area. Further research is needed with an emphasis on how to optimize the method of carbonizing and activating cotton nonwovens in order to further increase the surface area.

## 2.5 References

Bacon, R. & Tang, M. M. 1964, "Carbonization of Cellulose Fibers .2. Physical Property Study", *Carbon*, vol. 2, no. 3, p. 221-&.

Chen, Y. & Jiang, N. 2007, "Carbonized and activated non-wovens as high-performance acoustic materials: Part I - Noise absorption", *Textile Research Journal*, vol. 77, no. 10, pp. 785-791.

Garrido, J., Linaressolano, A., Martinmartinez, J. M., Molinasabio, M., Rodriguezreinoso, F., & Torregrosa, R. 1987, "Use of N<sub>2</sub> Vs Co<sub>2</sub> in the Characterization of Activated Carbons", *Langmuir*, vol. 3, no. 1, pp. 76-81.

Harry, M. & Francisco, R. R. 2006, *Activated Carbon*, 1 edn, Elsevier, United Kindom.

Huidobro, A., Pastor, A. C., & Rodriguez-Reinoso, F. 2001b, "Preparation of activated carbon cloth from viscous rayon - Part IV. Chemical activation", *Carbon*, vol. 39, no. 3, pp. 389-398.

Huidobro, A., Pastor, A. C., & Rodriguez-Reinoso, F. 2001a, "Preparation of activated carbon cloth from viscous rayon - Part IV. Chemical activation", *Carbon*, vol. 39, no. 3, pp. 389-398.

Iwasaki, S., Fukuhara, T., Yoshimura, Y., Sakaguchi, R., Shibutani, Y., & Abe, I. 2001, "Removal of endocrine-disrupting chemicals in water using textile-related wastes. I Removal of 4-nonylphenol by microporous carbons prepared from cotton waste", *Sen-I Gakkaishi*, vol. 57, no. 12, pp. 359-363.

Kadirvelu, K., Kavipriya, M., Karthika, C., Radhika, M., Vennilamani, N., & Pattabhi, S. 2003, "Utilization of various agricultural wastes for activated carbon preparation and application for the removal of dyes and metal ions from aqueous solutions", *Bioresource Technology*, vol. 87, no. 1, pp. 129-132.

Ko, T. H., Chiranairadul, P., & Lin, C. H. 1991, "The Influence of Continuous Stabilization on the Properties of Stabilized Fibers and the Final Activated Carbon-Fibers .1", *Polymer Engineering and Science*, vol. 31, no. 22, pp. 1618-1626.

Muto, A., Bhaskar, T., Tsuneishi, S., & Sakata, Y. 2005, "Activated carbon monoliths from phenol resin and carbonized cotton fiber for methane storage", *Energy & Fuels*, vol. 19, no. 1, pp. 251-257.

Smisek, M. & Cerny, S. 1970, *Active Carbon - Manufacture, Properties and Applications* Elsevier Publishing Company, New York.

Tang, M. M. & Bacon, R. 1964, "Carbonization of Cellulose Fibers .1. Low Temperature Pyrolysis", *Carbon*, vol. 2, no. 3, p. 211-&.

Wu, Q. L. & Pan, D. 2002, "A new cellulose based carbon fiber from a lyocell precursor", *Textile Research Journal*, vol. 72, no. 5, pp. 405-410.

## **Chapter 3 Focus Study on Preparation and Characterization of Cotton and Viscose Rayon Nonwovens**

### **3.1 Introduction**

The environmental problems and health concerns associated with hazard volatile gas emission are well recognized today. Activated carbon is an excellent adsorbent to solve these problems due to its special pore structures and high adsorption and desorption properties. A method to produce carbonaceous fibers by carbonizing and activating cellulosic fibers was reported in the 1960s (Bacon & Tang 1964;Tang & Bacon 1964). Since then, increasing attention has been drawn to the studies on the use of fibers and fabric assemblies as raw materials for carbonization.

The fiber nature enables fibers to be processed prior to activation and activation to produce many textile structures in the form of yarns, fabrics and webs. Taking nonwoven webs for example, they can be converted into specialty web materials by a certain condition of carbonization and activation. Carbonized textile materials could be widely used not only in technological sectors but also in consumers' daily life, from clothing to home interiors (Freeman et al. 1987;Freeman et al. 1988;Freeman & Gimblett 1987;Freeman & Gimblett 1988;Freeman, Gimblett, & Sing 1989a;Huang, Wang, & Wang 2002).

Current fiber precursors for producing commercial activated carbon fibers and fabrics include viscose rayon (Huidobro, Pastor, & Rodriguez-Reinoso 2001), acrylic, polyacrylonitrile (PAN) (Ko, Chiranairadul, & Lin 1991), Novoloid (novolac resin), and lyocell (Wu & Pan 2002).

However, wider applications are limited due to their price because more than 80% of fiber material weight was burned off during the carbonization and activation process. Thus, if a low cost fibrous material could be employed and transformed into carbon fiber, cheaper ACF could be manufactured and applied to more end use fields.

Cellulosic fibers are one of the major precursors for producing ACF in industry by a simple and controllable manufacturing process. Pore structures and mechanical properties of activated carbon fibers are dependent upon the fiber precursor and method of preparation. Fibrous hollow activated carbons from softwood and hardwood fibers were examined and compared. It was found that the adsorption capacity of these ACFs was comparable to that of the commercially available ACFs (Asakura et al. 2004). Bagasse from the sugar milling process is also of particular interest because it is a renewable resource available in large quantity and low cost. Valix *et al* reported the pore structure and chemical properties of activated carbon generated from unwashed bagasse. They concluded that the activated carbon had high adsorption properties (acid blue dye) (Valix, Cheung, & Mckay 2004).

However, the wood or bagasse fibers are too short to make high quality fiber materials used in industries or consumer areas. Long cellulose fibers, including natural fibers such as cotton, flax, jute, kenaf and hemp, or manufactured cellulosic fibers like rayon, lyocell and cellulose acetate, are potential precursors for activated carbon fibers. For natural fibers, five biomass types of hemp, flax, jute, coir and abaca were pyrolysed in a fixed bed reactor activated with steam in a char activation reactor. Surface areas were around  $800\text{m}^2\text{g}^{-1}$  and coir with highest product yield (Reed & Williams 2004). Jute and coconut fibers were reported as raw materials for the production of fibrous activated carbons. Because of their different compositions in terms of cellulose, hemicellulose and lignin, the activated coconut fibers presented a higher surface area than that obtained from jute. Chemical activation method by phosphoric acid was more effective than physical activation (Phan et al. 2006). By using diverse spectroscopic methods as Fourier-transform infrared spectroscopy (FTIR), X-ray photoelectron spectroscopy (XPS) and micro-Raman spectrometry, the initial steps of carbonization of cellulose, lignin were analyzed (Ishimaru et al. 2007).

Intensive research has been done on the preparation of activated carbon fiber from the regenerated cellulose fiber rayon. Rodriguez-Reinoso *et al* showed some theoretical and experimental approaches lead to narrow and uniform micropores (Rodriguez-Reinoso *et al.* 1989). X-ray examination of different representative samples of rayon charcoal cloth confirmed a direct correlation between cellulose molecular orientation and preferred orientation of the carbonized fiber (Bacon & Tang 1964). Commercially, the processing routine generally includes impregnation with chemicals. Chemical pretreatment of viscose rayon with a number of transition metal oxo-complexes and chlorides showed that chars had a wide range of pore structure type according to the particular impregnant employed (Freeman, Gimblett, & Sing 1989b). Some research also laid emphases on the molecular and crystal transitions of rayon during the heat treatment as well as the porosity of ACF in the presence of 4% dibasic ammonium phosphate (DAP). The very tiny crystallites could be formed near 800°C and activation seemed to favor the crystallization. DAP also helped increase the surface area of ACF (Zeng & Pan 2008). The effect of carbonization conditions on the porosity, mechanical strength and oxygen surface groups showed that the slower the heating rate used in carbonization the more ordered the structure of resulting char (Rodriguez-Reinoso *et al.* 2000). Rayon manufacture uses a large amount of water and energy and contributes to the emission of zinc and hydrogen sulfide. After 1985, the production of rayon decreased dramatically in the U.S. and EU countries. Cotton is the most popular fiber crop produced in the U.S. This paper focuses on carbonizing and activating a cotton and rayon nonwoven fabric, so that specialty activated carbon fibers with high performance in chemical absorption and adsorption could be obtained.

ACF is an excellent adsorbent and has wide applications in many important fields, especially in chemical industry and personal protection. However, the literature is not extensive on effects of temperature, treatment time on the carbonization and activation processes under

experimental conditions where other factors are kept constant. This work is concerned with the influence of carbonization and activation conditions on the characteristics of activated carbon fibers. The following factors are examined:

- a) The effect of increasing heating temperature and heating time on changes in porosity and surface area of cotton and rayon.
- b) The effect of different fiber type on the carbonization and activation.
- c) The effect of different activation conditions on the development of porosity and increase in surface areas.

## **3.2 Experimental**

### 3.2.1 Activated Carbon Fiber Production

- **Materials**

Nonwoven webs were manufactured from viscose rayon and cotton fibers by carding machine and needle punching machine as described in 1.5.1.1.

- **Carbonization**

The viscose rayon and cotton nonwoven was cut into stripes of 10 mm long and 2 mm wide. Carbonization and activation steps were carried out in a vacuumed horizontal glass tube in the ASAP2020 instrument (Figure 12). Strips were carbonized in the tube under a flow of nitrogen of 100 ml/min at 20°C/min heating rate to different final temperatures range from 600 to 900°C. This temperature was held for 0.5 hour to 5 hours. In the carbonization step, H<sub>2</sub>O, CO, H<sub>2</sub>, CH<sub>4</sub> and C<sub>2</sub>H<sub>6</sub> were released.

- **Activation**

After carbonization, nitrogen was switched to CO<sub>2</sub> to activate fibers by physical method and micropores were further developed. In chemical activation, rayon or cotton nonwoven samples were impregnated with an aqueous solution of 1% ZnCl<sub>2</sub> for 12 hours. Then the samples

were taken out and pressed with a laboratory padding machine to remove the surplus solution. The samples were dried in an oven at 105°C, and further carbonized and activated in the glass tube with N<sub>2</sub> and CO<sub>2</sub>.

### 3.2.2 Characterization

- TGA Analysis

The thermal degradation of the nonwoven samples was tested using TGA between room temperature and 600°C at the heating rate of 5 °C/min. 5 mg of samples were tested.

- Yield Analysis

Yield is defined as the ratio of the weight of the samples after thermal treatment (carbonization and activation) to the weight of the samples before treatment. In chemical activation, when the treatment temperature exceed 600 °C for more than 0.5 hour the impregnants were completely burned away and true yields were obtained.

The total yield in the lab-scale experiment was calculated using the formula below:

$$\text{Percent yield} = \frac{\text{Weight after carbonization and activation}}{\text{Original Sample Weight}} \times 100\%, \quad (5)$$

- Nitrogen Adsorption and Surface Area Calculation

A physisorption analyzer ASAP 2020 (Micromeritics Inc.) was used for the measurement of nitrogen adsorption isotherms at 77K. Surface area values were calculated from the experimental adsorption isotherm over a relative pressure range of 0.01 to 0.20 using the standard BET method. In this study, the evaluation of micropore volume was based on a t-plot model and the average pore size was calculated according to the notable BJH model (Barrett, Joyner, & Halenda 1951).

- X-Ray Diffraction Test

The instrument of D-5000 Dual Goniometer (Bruker/Siemens) was applied.

### 3.3 Results and Discussions

#### 3.3.1 Weight Loss Behavior

Figure 20 shows in detail the experimental curve for the cotton pyrolysis at a heating rate of 5°C/min. Cotton commonly consists of 94% cellulose. For the cotton cellulose, first stage (< 250°C) involved the removal of water content and some re-arrangement of the cellulose structure (Gurudatt, Tripathi, & Sen 1997).

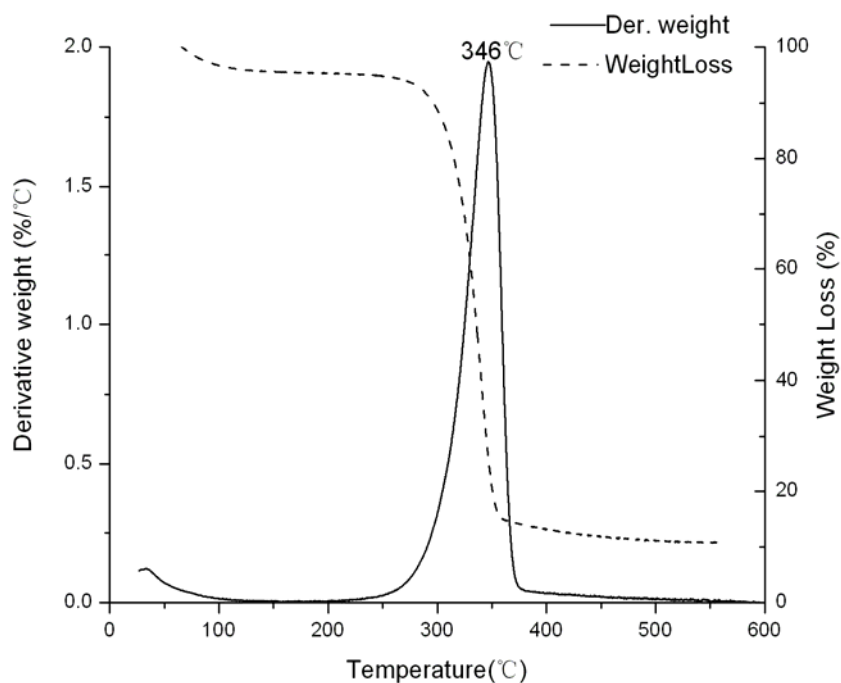

Figure 20 Thermal Analysis of Cotton Nonwoven

It shows that water content is about 5% in the first stage. There is a considerable decrease in weight loss in the region of 250°C to 400°C. At this stage of pyrolytic degradation, splitting of C-O and C-C bonds occurs with production of tars, water, carbon monoxide, and carbon dioxide (Pastor et al. 1999). After 400°C, aromatization is the main reaction and the weight almost no longer decreases. The effect of carbonization mainly depends on the temperature, time, and heating rate. Usually, slow heating rates and higher heating temperatures favor a more ordered

char. The carbonization yields increase as heating rates decrease (Pastor, Rodriguez-Reinoso, Marsh, & Martinez 1999). The ultimate weight loss is around 90%.

### 3.3.2 Surface Characterization of Activated Carbon Fibers

When heating temperature went higher from 600°C to 800°C and heating time from 0.5 hour to 4 hours, the final yields of rayon and cotton after carbonization and activation decreased from 15.68% to 7.37% (Table 4). The surface properties of cotton and rayon fiber carbonized and activated at different treatment time and heating temperature are also listed in Table 4.

Table 4 Surface Characteristics of Rayon and Cotton

Nonwoven Sample	Temperature (°C)	Time (hr)	Yield (%)	BET Surface Area (m <sup>2</sup> /g)	BJH Average Pore Diameter (Å)
Cotton	600	0.5	13.08	216.95	38.17
Rayon	600	0.5	15.68	239.07	35.23
Cotton	600	1	12.85	249.06	35.66
Rayon	600	1	14.10	257.03	34.76
Cotton	600	2	12.75	251.47	37.21
Rayon	600	2	14.49	266.47	32.37
Cotton	600	4	11.58	246.95	45.62
Rayon	600	4	14.68	210.42	43.73
Cotton	700	0.5	12.33	244.22	33.62
Rayon	700	0.5	14.82	246.03	31.95
Cotton	700	1	12.36	262.37	36.03
Rayon	700	1	13.98	277.73	36.95
Cotton	700	2	12.15	250.08	39.96
Rayon	700	2	12.51	222.42	36.31
Cotton	700	4	11.14	258.30	40.10
Rayon	700	4	12.60	240.67	37.60
Cotton	800	0.5	11.51	361.29	34.07
Rayon	800	0.5	11.59	366.51	33.45
Cotton	800	1	10.52	376.19	41.14
Rayon	800	1	10.52	493.80	30.40
Cotton	800	2	10.24	452.48	31.42
Rayon	800	2	9.86	585.08	33.22
Cotton	800	4	7.37	632.19	30.90
Rayon	800	4	7.23	879.05	27.67
Cotton	800	5	3.08	982.10	--
Rayon	800	5	0	--	--

These variables to evaluate the surface adsorption properties include total surface area ( $m^2/g$ ) ( $S_{BET}$ ) and BJH average pore diameter ( $\text{\AA}$ ) ( $D_{BJH}$ ). In general, higher surface areas ( $S_{BET}$ ) resulted in higher adsorption capacities, but adsorption capacities were also related to pore size ( $D_{BJH}$ ). The values of  $S_{BET}$  and  $D_{BJH}$  depended on the conditions of carbonization and activation, i.e. heating temperature and heating time. Usually, heating temperature and heating time significantly influence  $S_{BET}$  and  $D_{BJH}$ . In this chapter, the effects of heating time and treatment temperature are examined for changes in final product yield and surface properties including total surface area and BJH average pore diameter.

- Treatment Time Effect

The increase of weight loss reflected the degree of pyrolysis. The yield curves of rayon and cotton as a function of the heating time are shown in Figure 21. Compared with the rayon, pure cotton had slightly lower yield at 600°C and 700°C with the same treatment time. However, this yield difference at 800°C between rayon and cotton was small. The yield of rayon ACF of 7.23% was very close to the yield of cotton ACF of 7.37% when processed at 800°C for 4 hours.

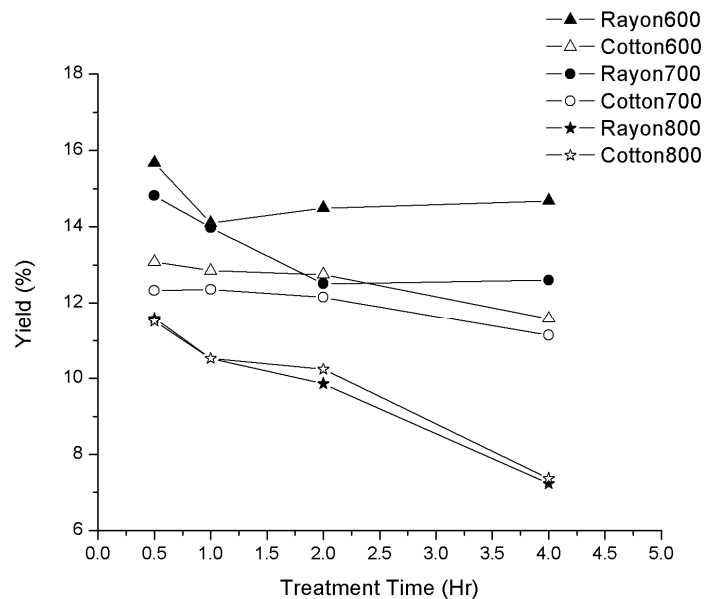

Figure 21 Yield Curves of Rayon and Cotton for Treatment Time Effect

Despite the low yield, the characteristics of activated carbon fibers made from rayon and cotton were still promising. The surface areas for ACF rayon and cotton which are plotted as a function of treatment time in Figure 22 provide further insight into the effect of treatment time on the changes of the surface area.

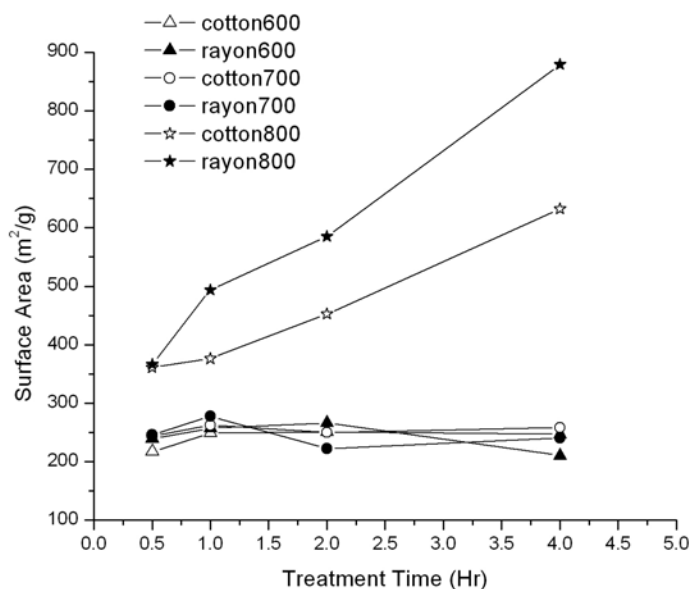

Figure 22 Surface Area of Rayon and Cotton for Treatment Time Effect

With the increase of treatment time from 0.5 hour to 4 hours,  $S_{BET}$  increased significantly for both rayon and cotton fibers when heated at 800°C. When heating temperature was 600°C or 700°C,  $S_{BET}$  was below 300 m<sup>2</sup>/g and did not increase with the increase of treatment time.  $S_{BET}$  rose up to 632.19 m<sup>2</sup>/g for cotton and 879.05 m<sup>2</sup>/g for rayon under the heating condition of 800°C and the heating time of 4 hours.  $S_{BET}$  reached 982.10 m<sup>2</sup>/g for cotton fiber when heating time was extended to 5 hours (Table 4). However, the yield was only 3% since most substances were pyrolyzed into gas or liquid. When rayon fiber was heated at 800°C for 5 hours, no residue left.

The effect of treatment time on BJH average pore diameter is shown in Figure 23. When rayon or cotton nonwovens were heated less than 2 hours, it was hard to tell the effect of

treatment time on BJH. When the treatment time extended to four hours at 800°C, BJH pore diameters decreased to 27.67 Å for rayon ACF and 30.90 Å for cotton ACF. At treatment time of 4 hours, rayon ACF nonwoven had smaller pore size than the cotton ACF.

The best treatment time for manufacturing rayon and cotton ACF nonwovens with good surface properties were recommended around four hours and the yields for both rayon and cotton are above 7%.

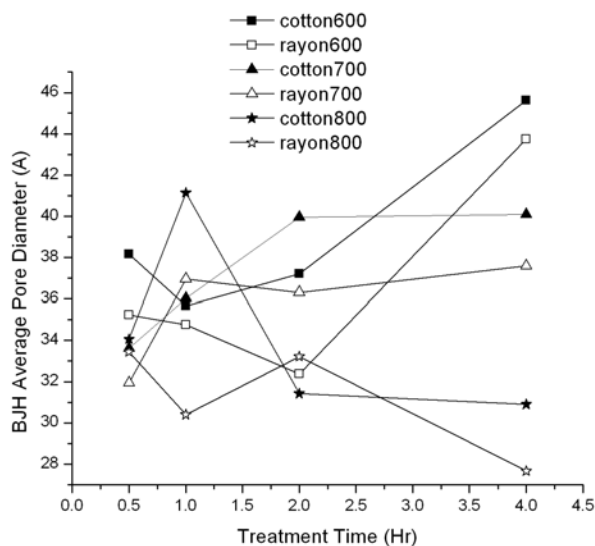

Figure 23 Pore Diameter Rayon and Cotton for Treatment Time Effect

- Treatment Temperature Effect

The yield curves of rayon and cotton as a function of the heating temperature are shown in Figure 24. Yields of rayon and cotton were decreased significantly with the increase of temperature due to pyrolysis.

Figure 25 and Figure 26 illustrate the effect of treatment temperature on the surface area and pore size. Surface areas increased with the increase of temperature. When the temperature increased from 700°C to 800°C, the steep lines showed the dramatically enhancement of surface areas for rayon and cotton ACF. If the heating temperature increased to 900°C for 0.5 hour,

neither rayon nor cotton fiber had any residue. Rayon ACF demonstrated a higher  $S_{BET}$  than cotton ACF in the same processing condition, typically at 800°C of heating temperature.

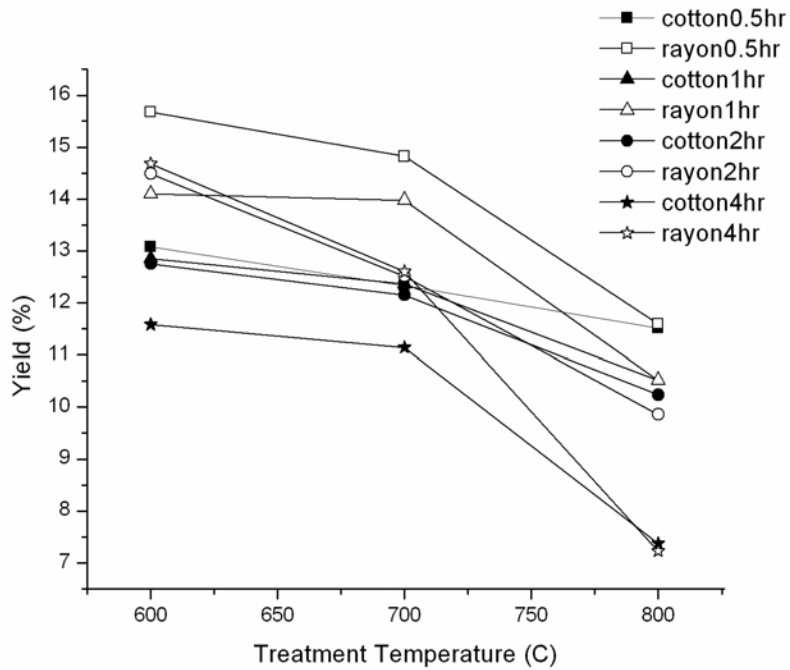

Figure 24 Yield of Rayon and Cotton for Treatment Temperature Effect

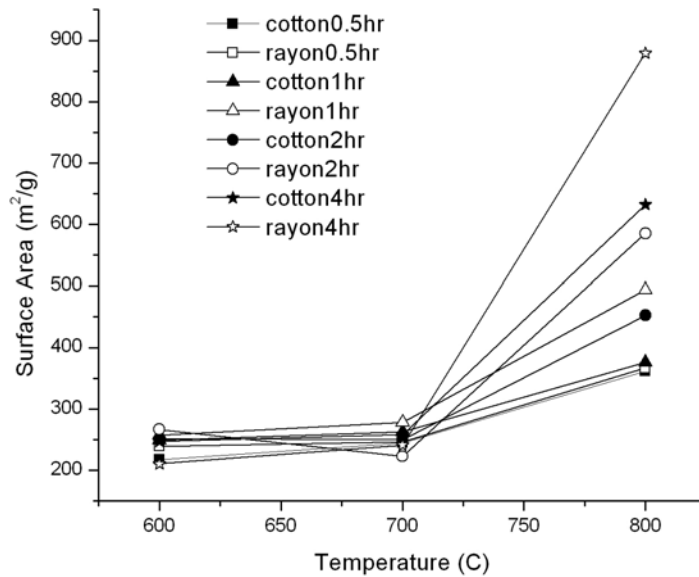

Figure 25 Surface Area of Rayon and Cotton for Treatment Temperature Effect

In Figure 26, high temperature tends to decrease pore size especially when the cotton or rayon nonwovens are heated for four hours. BJH average pore diameter of rayon ACF manufactured at 800°C for four hours is as small as 27.67 Å which is close to the diameter of micropore (< 20 Å). Thus, 800°C is the best treatment temperature for manufacturing cotton and rayon ACF nonwoven with high surface area and small pore size.

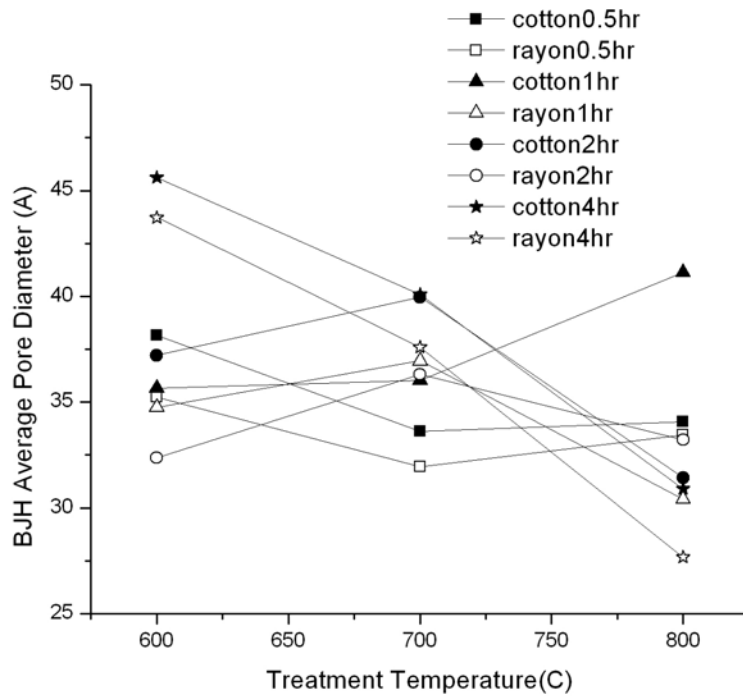

Figure 26 Pore Size of Rayon and Cotton for Treatment Temperature Effect

- Interaction Between Treatment Time and Temperature

The interaction of temperature and time was examined using the method of two way analysis of variance (ANOVA). As shown in Table 5, the factors of Temperature (P value <0.0001), Time (P value = 0.0229) and interaction (P value = 0.0081) all have significant effects on  $S_{BET}$ . For  $D_{BJH}$ , Temperature (P value = 0.0095) and Interaction (P value = 0.0218) have significant influence. Based on this statistical inference, it could be considered that the interaction of Temperature and Time existed. As illustrated in Figure 22 and Figure 25, the

higher temperature and the more treatment time the cotton or rayon fibers are treated during carbonization and activation, the higher the surface area the ACF possesses.

Table 5 P Value of ANOVA

Dependent Variables	Factors		
	Temperature	Time	Interaction
$S_{BET}$	<0.0001	0.0229	0.0081
$D_{BJH}$	0.0095	0.2802	0.0218

Because the interactions between time and temperature had significant effects on both surface area and pore diameter, three dimensional graphs in terms of treatment time and temperature with bottom contour are plotted in Figure 27 and Figure 28 for further examination.

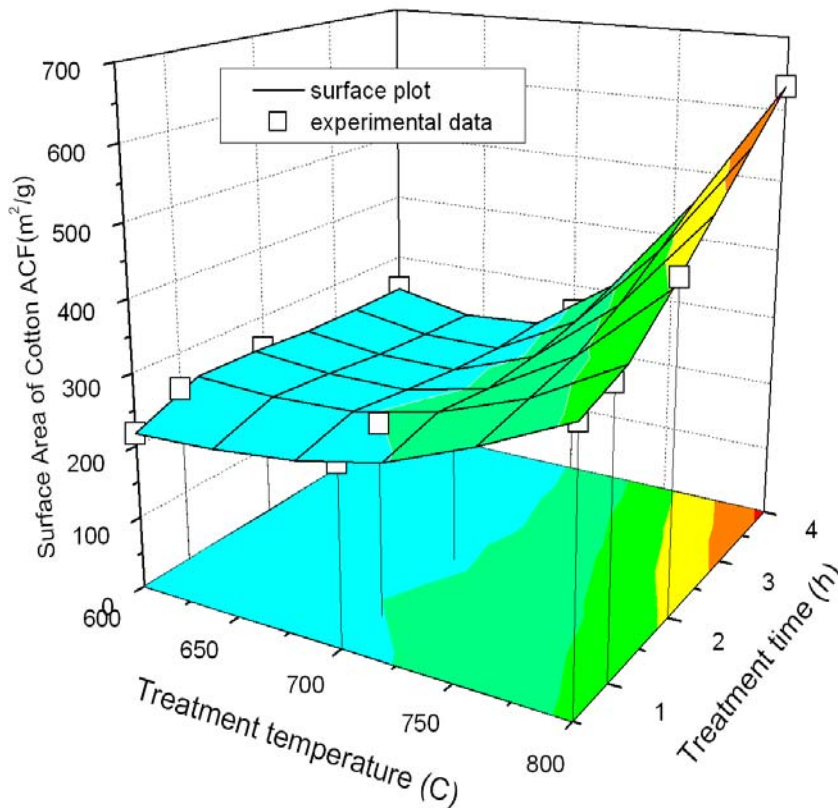

(a)

Figure 27 3D Surface Area on Temperature and Time (figure con't.)

(a) Cotton ACF (b) Rayon ACF

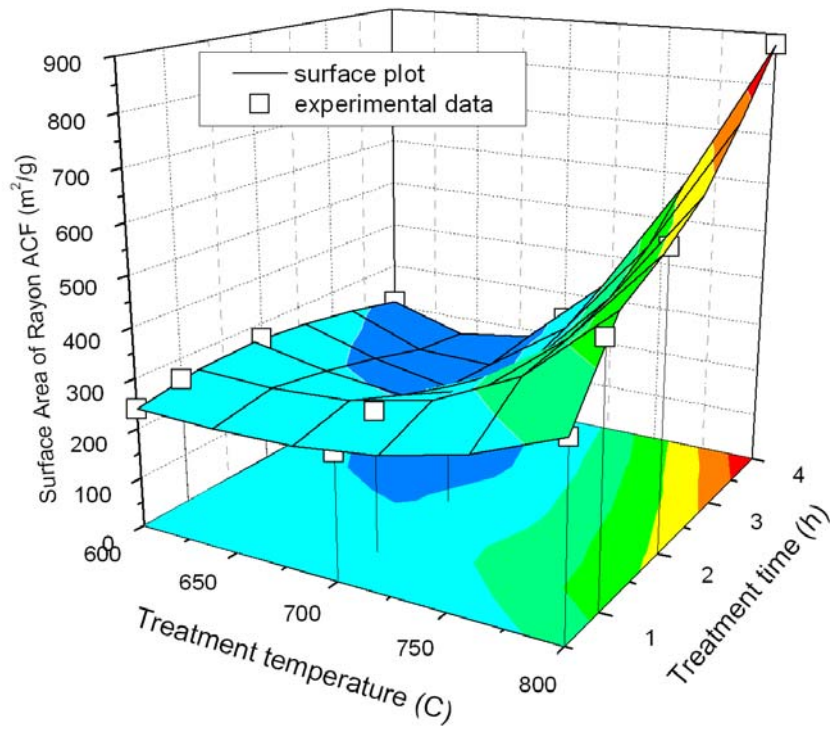

(b)

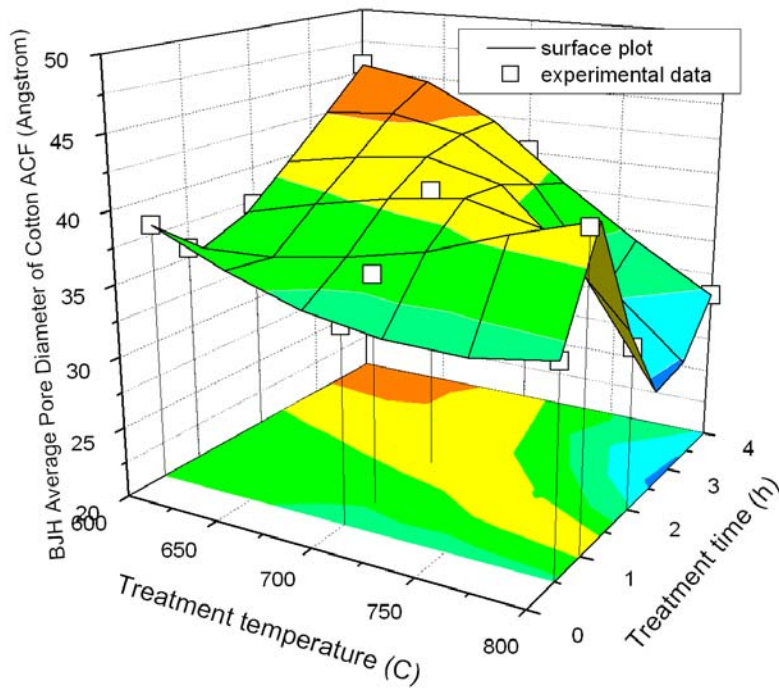

(a)

Figure 28 3D BJH Pore Diameter on Temperature and Time (figure con't.)  
 (a) Cotton ACF (b) Rayon ACF

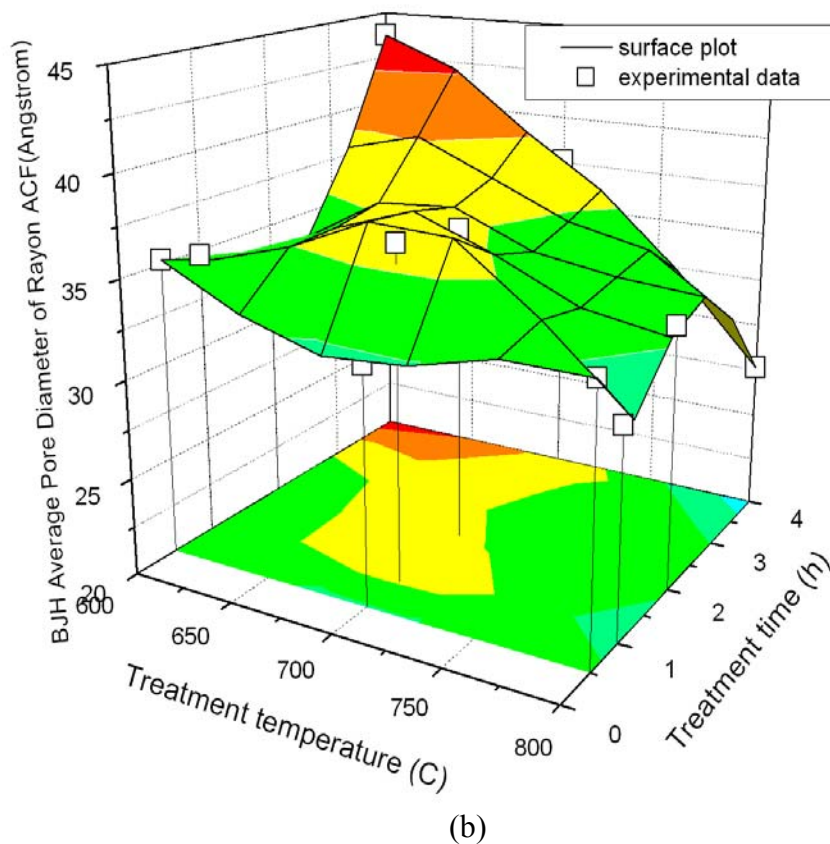

In Figure 27, high temperature increased surface area when the treatment time kept constant for both cotton and rayon fibers. In the same way, long treatment time also favored high surface area when the temperature was fixed. In Figure 28, high temperature contributed to the development of micropores with constant treatment time, while the effect of treatment time on pore size was not significant when the treatment time kept constant. With long treatment time, the surface area increased and the size of micropores increased, with a higher proportion of wide micropores and mesopores contributing to the increase of surface area. As a result, there was a compensation for the decrease in the loss of narrow microporosity.

### 3.3.3 Physical Activation VS Chemical Activation

The isotherm curves of physical and chemical activations of cotton fibers at 800 °C for 4 hours are shown in Figure 29. These two curves are totally different from each other.

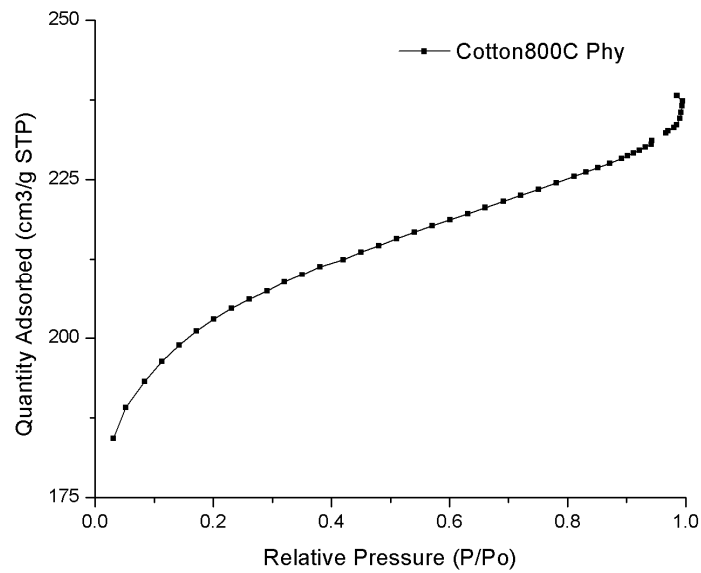

a)

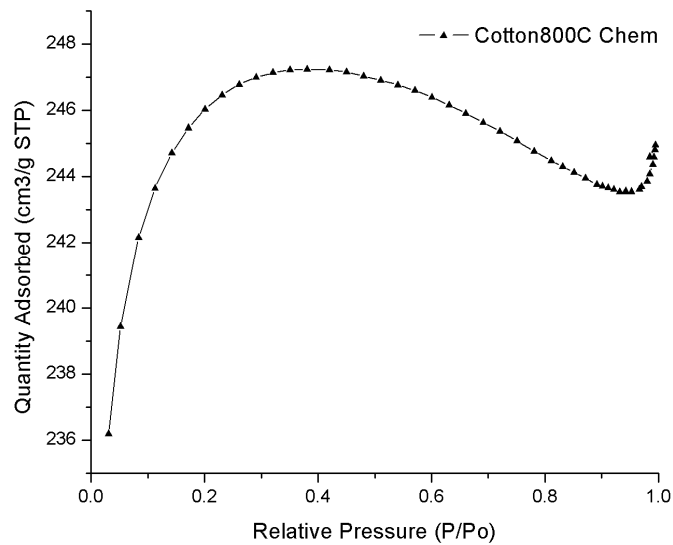

b)

Figure 29 Isotherm Curves of Cotton Fibers obtained at 800 C for 4 Hours  
 a) Physical Activation b) Chemical Activation

The slope of nitrogen uptake at very low relative pressure for chemical isotherm is steeper than physical isotherm. In the isotherm curve of chemical activation, nitrogen adsorption reaches a maximum value of adsorption from  $p/p^0$  values from zero to about 0.3. It suggests that

cotton fiber with chemical activation contains a large quantity of micropores since micropores are filled at relatively low partial pressures. The increase of capacity for adsorbing N<sub>2</sub> at the low relative pressure with the pretreatment of ZnCl<sub>2</sub> demonstrates further development of micropores. At high relative pressure region  $p/p^0 > 0.9$ , the isotherm curves show the presence of mesopores and macropores. In Figure 29, the activated carbon fibers made from physical and chemical activation both contain a considerable amount of mesopores and macropores.

The yield, BET surface area, pore volume and average pore diameter of cotton fibers activated by physical and chemical methods is summarized in Table 6.

Table 6 Surface Area, Pore Volume and Pore Diameter

Activation Method	Yield (%)	BET Surface Area (m <sup>2</sup> /g)	Total Pore Volume (cm <sup>3</sup> /g)	t-Plot Micropore Volume (cm <sup>3</sup> /g)	Percentage of Micropore Volume (%)	BJH Average Pore Diameter (Å)
Physical	7.37	632.19	0.3676	0.2460	66.9	30.90
Chemical	19.50	747.63	0.3783	0.3574	94.4	23.26

\*The cotton samples were heated at 800 °C for 4 hours.

The chemical activation significantly increased production yield from 7.37% to 19.50%. However the chemical treatment made the fibers more brittle and fragile. BET surface areas of carbonized cotton nonwoven increase from 632.19 m<sup>2</sup>/g to 747.63 m<sup>2</sup>/g with chemical treatment. Total pore volume and micropore volume were also increased significantly. It was also confirmed by Figure 29 that the percentage of micropore volume indicated that with chemical treatment, the pores in the cotton nonwoven were occupied by micropores.

It has been observed that the pore size decreases with the chemical treatment. The BJH Average Pore Diameter of cotton is 23.26 Å, i.e., close to micropore size (<20nm). The adsorption isotherm and surface porous data are both demonstrating that the effect of chemical treatment of cotton nonwoven fibers are significant. Chemical treatment seems to improve the development of microporosity.

### 3.3.4 Repeating Test

To verify the results, the cotton fibers were carbonized and activated three times at 800°C for different treatment time from 0.5 hour to 4 hours. It could be observed that all the surface area values range from of 361.29 to 668.18 m<sup>2</sup>/g. The treatment time brings significant effect on the surface area (F value = 209, p value < 0.0001). The more treatment time the cotton fiber was endured, the greater value the surface area of activated carbon possessed. Since the number of trials was small, the assumption of normality might not satisfy. Nonparametric method was applied and the  $S_{\text{BET}}$  values of ACF were tested by the Wilson's scores (Table 7).

Table 7 Surface Area Repeating Test

	Cotton 0.5Hr	Cotton 1Hr	Cotton 2Hr	Cotton 4Hr
1	361.29	376.19	452.48	632.19
2	386.28	385.95	489.83	643.63
3	372.37	391.48	465.74	668.73
Mean	373.31	384.54	469.35	648.18
Wilcoxon Sum Scores	8	13	24	33

\* Expected Wilcoxon Sum Scores under  $H_0$  is 19.5 ( $H_0$ : no difference among groups at  $\alpha=0.05$ ).

In Table 7, the Wilcoxon sum score of ACF cotton nonwoven heated for 4 hours is highest and Wilcoxon sum scores increase with the increase of treatment time at 800°C. The scores of BET surface area of 0.5 and 1 hour treatment time are less than the expected value of 19.5, showing no significant difference in  $S_{\text{BET}}$  values when the cotton fibers are carbonized and activated from 0.5 hour to 1 hour. This indicates that the cotton nonwovens could be good precursors after carbonization and activation with high surface area and the results are very convincing by three repeating tests. It also reveals that increasing treatment time of carbonization and activation improves surface area significantly.

### 3.3.5 X-Ray Diffraction Data

Figure 30 exhibits the X-Ray Diffractive spectrum of the cotton fiber. The brown curve indicates a typical cellulose molecule  $[\text{C}_6\text{H}_{10}\text{O}_5]_n$  with three peaks at  $2\theta = 14.988$ ; 16.487; and

22.781 respectively. The red curve reflects the carbonized cotton structure. The blue curve is from the carbonized and activated cotton. The overlapping plot indicates that the cellulose crystallite disappears after carbonization and activation, replaced by a graphitized structure showing no diffracting peaks.

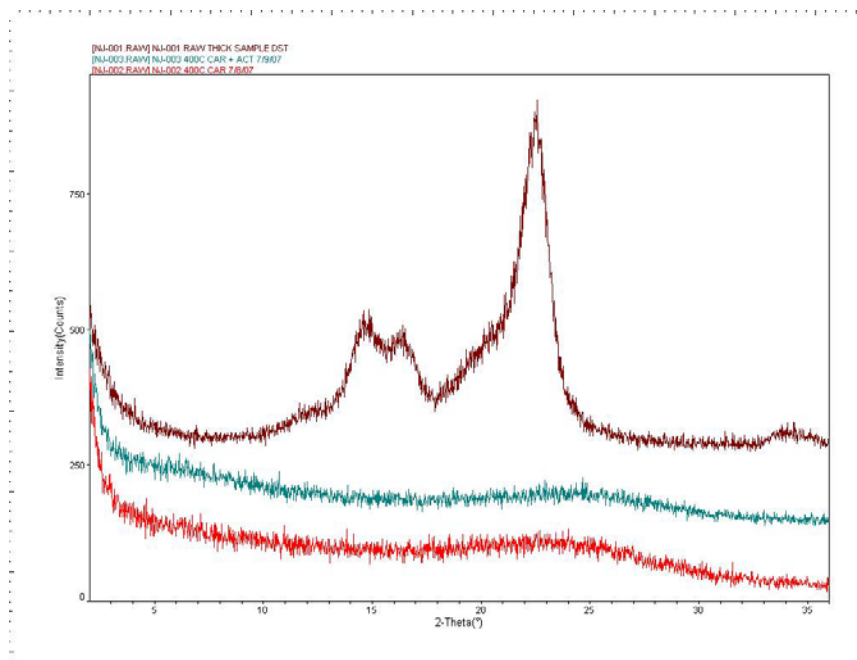

Figure 30 X-Ray Diffraction of Cotton Fiber before and after Carbonization

### 3.4 Conclusions

Cellulosic nonwoven fabrics made of rayon and cotton could be good precursors for producing activated carbon materials used as high-performance adsorbents and absorbents because of their high specific surface area and small micropore diameter. TGA results showed that at 346 °C cellulose was pyrolyzed quickly and the ultimate weight loss is around 90%. The surface area and porosity of the derived activated carbon was determined. ACF made from rayon fabrics showed slightly high surface area than cotton. The increase of carbonization and activation temperature resulted in a high adsorptive capacity and microporosity. Longer heating time also contributes to high surface area. Surface area of 879.05 m<sup>2</sup>/g and BJH average diameter of 27.67 Å were achieved when rayon was carbonized and activated at 800°C for 4 hours. Cotton

could endure longer heating time up to 5 hours at 800 °C than rayon and surface area of cotton ACF is as high as 982.10 m<sup>2</sup>/g. The interactions between time and temperature have significant effects on both surface area and pore diameter. Carbonization and activation conducted at 800°C for four hours is the optimum condition for manufacturing cotton and rayon ACF. Impregnation of cotton fabric with ZnCl<sub>2</sub> modifies the pyrolysis process, increasing final ACF yield, surface area and developing micropores. This study demonstrated that activated carbon fiber with high adsorption capacity and microporosity could be prepared from rayon and cotton nonwoven fabrics by heating at 800 °C for four hours.

### 3.5 References

- Asakura, R., Morita, M., Maruyama, K., Hatori, H., & Yamada, Y. 2004, "Preparation of fibrous activated carbons from wood fiber", *Journal of Materials Science*, vol. 39, no. 1, pp. 201-206.
- Bacon, R. & Tang, M. M. 1964, "Carbonization of Cellulose Fibers .2. Physical Property Study", *Carbon*, vol. 2, no. 3, p. 221-&.
- Barrett, E. P., Joyner, L. G., & Halenda, P. P. 1951, "The Determination of Pore Volume and Area Distributions in Porous Substances .1. Computations from Nitrogen Isotherms", *Journal of the American Chemical Society*, vol. 73, no. 1, pp. 373-380.
- Freeman, J. J. & Gimblett, F. G. R. 1987, "Studies of Activated-Charcoal Cloth .2. Influence of Boron-Containing Impregnants on the Rate of Activation in Carbon-Dioxide Gas", *Carbon*, vol. 25, no. 4, pp. 565-568.
- Freeman, J. J. & Gimblett, F. G. R. 1988, "Studies of Activated-Charcoal Cloth .4. Influence of Phosphate Impregnants on the Rate of Activation in Carbon-Dioxide Gas", *Carbon*, vol. 26, no. 4, pp. 501-505.
- Freeman, J. J., Gimblett, F. G. R., Roberts, R. A., & Sing, K. S. W. 1987, "Studies of Activated-Charcoal Cloth .1. Modification of Adsorptive Properties by Impregnation with Boron-Containing Compounds", *Carbon*, vol. 25, no. 4, pp. 559-563.
- Freeman, J. J., Gimblett, F. G. R., Roberts, R. A., & Sing, K. S. W. 1988, "Studies of Activated-Charcoal Cloth .3. Mesopore Development Induced by Phosphate Impregnants", *Carbon*, vol. 26, no. 1, pp. 7-11.
- Freeman, J. J., Gimblett, F. G. R., & Sing, K. S. W. 1989b, "Studies of Activated-Charcoal Cloth .5. Modification of Pore Structure by Impregnation with Certain Transition-Metal Salts and Oxo-Complexes", *Carbon*, vol. 27, no. 1, pp. 85-93.

- Freeman, J. J., Gimblett, F. G. R., & Sing, K. S. W. 1989a, "Studies of Activated-Charcoal Cloth .5. Modification of Pore Structure by Impregnation with Certain Transition-Metal Salts and Oxo-Complexes", *Carbon*, vol. 27, no. 1, pp. 85-93.
- Gurudatt, K., Tripathi, V. S., & Sen, A. K. 1997, "Adsorbent carbon fabrics: New generation armour for toxic chemicals", *Defence Science Journal*, vol. 47, no. 2, pp. 239-250.
- Huang, J. M., Wang, I. J., & Wang, C. H. 2002, "Scanning force microscopy studies of the surface structure of activated carbon fabric", *Textile Research Journal*, vol. 72, no. 2, pp. 140-146.
- Huidobro, A., Pastor, A. C., & Rodriguez-Reinoso, F. 2001, "Preparation of activated carbon cloth from viscous rayon - Part IV. Chemical activation", *Carbon*, vol. 39, no. 3, pp. 389-398.
- Ishimaru, K., Hata, T., Bronsveld, P., Meier, D., & Imamura, Y. 2007, "Spectroscopic analysis of carbonization behavior of wood, cellulose and lignin", *Journal of Materials Science*, vol. 42, no. 1, pp. 122-129.
- Ko, T. H., Chiranairadul, P., & Lin, C. H. 1991, "The Influence of Continuous Stabilization on the Properties of Stabilized Fibers and the Final Activated Carbon-Fibers .1", *Polymer Engineering and Science*, vol. 31, no. 22, pp. 1618-1626.
- Pastor, A. C., Rodriguez-Reinoso, F., Marsh, H., & Martinez, M. A. 1999, "Preparation of activated carbon cloths from viscous rayon. Part I. Carbonization procedures", *Carbon*, vol. 37, no. 8, pp. 1275-1283.
- Phan, N. H., Rio, S., Faur, C., Le Coq, L., Le Cloirec, P., & Nguyen, T. H. 2006, "Production of fibrous activated carbons from natural cellulose (jute, coconut) fibers for water treatment applications", *Carbon*, vol. 44, no. 12, pp. 2569-2577.
- Reed, A. R. & Williams, P. T. 2004, "Thermal processing of biomass natural fibre wastes by pyrolysis", *International Journal of Energy Research*, vol. 28, no. 2, pp. 131-145.
- Rodriguez-Reinoso, F., Garrido, J., Martinmartinez, J. M., Molinasabio, M., & Torregrosa, R. 1989, "The Combined Use of Different Approaches in the Characterization of Microporous Carbons", *Carbon*, vol. 27, no. 1, pp. 23-32.
- Rodriguez-Reinoso, F., Pastor, A. C., Marsh, H., & Huidobro, A. 2000, "Preparation of activated carbon cloths from viscous rayon Part III. Effect of carbonization on CO<sub>2</sub> activation", *Carbon*, vol. 38, no. 3, pp. 397-406.
- Tang, M. M. & Bacon, R. 1964, "Carbonization of Cellulose Fibers .1. Low Temperature Pyrolysis", *Carbon*, vol. 2, no. 3, p. 211-&.
- Valix, M., Cheung, W. H., & Mckay, G. 2004, "Preparation of activated carbon using low temperature carbonisation and physical activation of high ash raw bagasse for acid dye adsorption", *Chemosphere*, vol. 56, no. 5, pp. 493-501.

Wu, Q. L. & Pan, D. 2002, "A new cellulose based carbon fiber from a lyocell precursor", *Textile Research Journal*, vol. 72, no. 5, pp. 405-410.

Zeng, F. L. & Pan, D. 2008, "The structural transitions of rayon under the promotion of a phosphate in the preparation of ACF", *Cellulose*, vol. 15, no. 1, pp. 91-99.

## Chapter 4 Acoustical Evaluation of Carbonized and Activated Cotton Nonwovens \*

### 4.1 Introduction

Activated carbon materials are ideal for use as high-performance adsorbents and absorbents, because of their very high specific surface area up to 2500 m<sup>2</sup>/g and a high micropore volume up to 1.6 ml/g (Smisek & Cerny 1970).

The methods of producing activated carbon fibers (ACF) by carbonizing and activating cellulosic fibers have been reported since the 1960s (Bacon & Tang 1964; Tang & Bacon 1964). Compared to activated carbon granules or powder, ACF has a significantly different microporous structure (Carrott & Freeman 1991; Ehrburger, Pusset, & Dziejzinl 1992; Starek, Zukal, & Rathousky 1994). Previous research has reported that the ACF product has the advantages of product quality consistency and much faster dynamic adsorption characteristics that allow less weight to be used for a given application than granulated or powdery form (Brown et al. 1987).

This paper focuses on carbonizing and activating a cotton nonwoven fabric. Cotton is the most popular fiber crop produced in the U.S. Cotton fiber also has a hollow structure that helps increase surface area and porosity. Thus, a specialty cotton nonwoven with high performance in chemical absorption and adsorption could be obtained.

Reported end uses of the activated carbon fiber fabrics cover many industrial sectors with the main applications focusing on personal safety equipment (protective clothing and masks), solvent recovery, water/air purification, wastewater treatment, and heat and electric insulation (Freeman et al. 1987; Freeman et al. 1988; Freeman & Gimblett 1987; Freeman & Gimblett 1988; Freeman, Gimblett, & Sing 1989; Huang, Wang, & Wang 2002). However, there is a lack

---

\* Jiang N., Chen Y., Acoustical Evaluation of Carbonized and Activated Cotton Nonwovens, *Bioresource Technology*, in press.

of reports on activated carbon fiber materials for acoustical applications. Textile fabrics, particularly nonwoven fabrics, have been commonly used for sound absorption, because of a special structure formed by fiber or yarn in fabrics (Lou, Lin, & Su 2005; Shoshani & Yakubov 1999; Shoshani & Yakubov 2000a; Shoshani & Yakubov 2000b; Shoshani 1990; Shoshani & Wilding 1991).

In general, dry porous media saturated with air were capable of reducing the level of ambient noise. Sound transmission loss is the reduction in noise level resulting from passage through an obstruction. The best way to reduce sound transmission is to use construction techniques that dampen vibration and convert sound energy into heat. Activated carbon fiber fabrics have two levels of porous structures: macropores among fibers and yarns; and micropores on the surface of activated carbon fiber. This unique fabric architecture renders a great potential for the activated carbon fiber fabrics to be used as high-performance and cost-effective acoustical materials.

A major purpose of this study is to manufacture carbonized and activated cotton nonwoven and explore its potential as a renewable acoustic material for specialty industrial applications. Moreover, cotton based activated carbon fabrics tend to have weak mechanical properties after carbonization and activation at high temperatures. This may limit some prospective end uses for the activated carbon fabrics. The tensile strength of the cotton nonwoven and the carbonized and activated cotton nonwoven is evaluated.

## **4.2 Experimental**

- **Sample Preparation**

Carbonization and CO<sub>2</sub> activation of the cotton nonwoven was carried out in an oven with nitrogen or CO<sub>2</sub> atmosphere at 350°C and a heating rate of 20°C/min. The cotton nonwoven was held in the oven for 20 min.

The experimental acoustical nonwoven was designed with a composite structure. This nonwoven composite has two layers: a base layer and a surface layer (Figure 26). The base layer nonwoven was raw cotton nonwoven (unbleached). Three different nonwoven products were employed as the surface layer respectively. These surface layer nonwovens were bleached cotton nonwoven, ACF cotton nonwoven, and glassfiber nonwoven. The glassfiber web was produced by Johns Manville (Denver, CO, USA). The specifications of the materials used for this study are listed in Table 8.

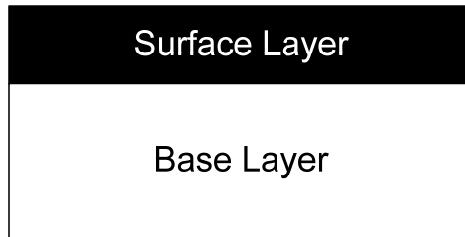

Figure 31 Acoustical Nonwoven Structure

Table 8 Fiber and Nonwoven Specifications

Nonwoven	Weight (g/m <sup>2</sup> )	Thickness (mm)
Cotton Base	62	35
Cotton Surface	274	3
ACF Cotton Surface	89	3
Glassfiber Surface	127	3

- Measurement of Sound Properties

The measurements of sound absorption and sound insulation of the nonwovens are described in 1.5.2.5.

### 4.3 Results and Discussion

#### 4.3.1 Sound absorption

The normal incidence sound absorption coefficients ( $\alpha$ ) of the cotton composites are determined as a function of the sound frequency ( $f$ ), as shown in Figure 27. The plotted curves combine the measured data in the low frequency range of 100-1600 Hz (using the Type 4206

large tube) and the measured data in the high frequency range (500-6400 Hz tested by the Type 4206 small tube) together to indicate a whole bandwidth of the 1/3 octave band frequency. The x-axis uses a log scale.

By examining the curve, it can be seen that Base & ACF cotton exhibits the highest ability for normal incident sound absorption, superior to Base & Glassfiber and Base & Cotton. Mostly because of a hollow structure of cotton fiber, the cotton nonwoven as surface layer absorbs more sound waves than the glassfiber nonwoven that is widely used as noise absorbent materials. The reason why the ACF cotton nonwoven possesses a significantly higher sound absorption coefficient than raw cotton may be explained by the highly porous surface structure of the ACF cotton nonwoven. More porous areas mean more air volumes allowed to flow into the ACF nonwoven structure. When incident noise waves hit the nonwoven composite, air vibration would happen in both the macroporous and microporous areas. As a result, the incident waves can be absorbed considerably.

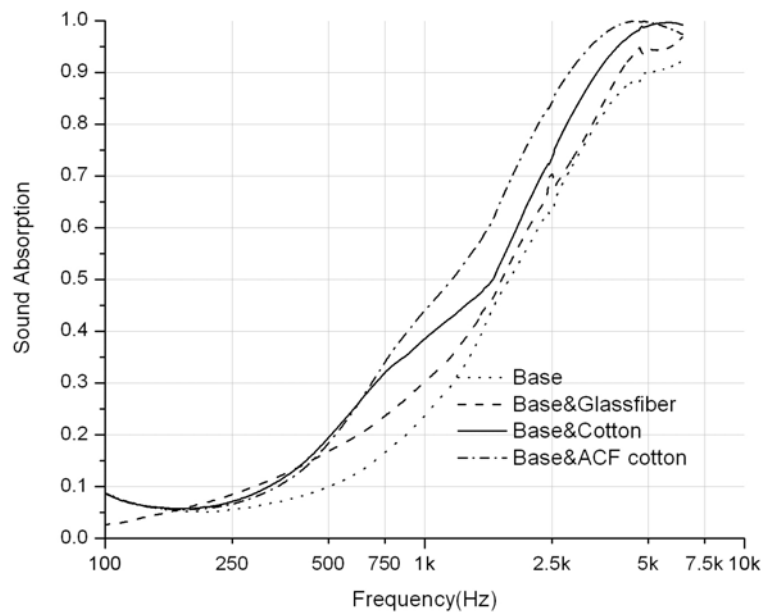

Figure 32 Sound transmission loss measurement system

For a numerical comparison, the average values of the sound absorption coefficients for all the nonwovens were calculated using the following equation:

$$\bar{\alpha} = \frac{\int_{F_1}^{F_2} \alpha(f) df}{F_2 - F_1}, \quad (6)$$

where  $F_1$  is lower bound of sound frequency in testing and  $F_2$  is upper bound of sound frequency in measurement. The computed  $\bar{\alpha}$  values between  $F_1$  (100 Hz) and  $F_2$  (6400 Hz) for the acoustic nonwovens are listed in Table 9.

Table 9 Means of Sound Absorption Coefficient ( $\bar{\alpha}$ )\*

	Base	Base&Glassfiber	Base&Cotton	Base&ACF
1	0.649	0.683	0.733	0.799
2	0.650	0.684	0.749	0.792
3	0.656	0.701	0.750	0.795
Mean	0.652	0.689	0.744	0.795
Wilcoxon Sum Scores	6	15	24	33

\* Expected Wilcoxon Sum Scores under  $H_0$  is 19.5 ( $H_0$ : no difference among groups at  $\alpha=0.05$ ).

It can be observed that all the  $\bar{\alpha}$  values for the three base layer nonwovens were within the range of 0.65 to 0.80. The Wilcoxon Sum Scores of  $\bar{\alpha}$  values of four nonwoven composites are ranked as tested by the nonparametric test of Wilcoxon sum score (Table 9). The ACF cotton nonwoven used as surface layer is significantly better than glassfiber and bleached cotton nonwovens. This indicates that the cotton nonwovens could be used as a biobased acoustic material with an outstanding ability to absorb normal incidence noise and a substantially lighter weight compared to the glassfiber nonwoven. It also reveals that the process of carbonization and activation for the cotton nonwoven improves sound absorption significantly. From Table 8, it can be seen that the ACF cotton surface layer features the light nonwoven structure. Its combination with the base layer forms the lightest composite structure. Therefore, the Base & ACF cotton composite seems an optimal acoustic material for the application of noise absorption.

### 4.3.2 Transmission Loss

Figure 28 shows the curves for transmission loss (TL) as a function of the sound frequency ( $f$ ) within the frequency range of 100-6400 Hz with log scale as x-axis. The curves indicate that the three surfaces of glassfiber, cotton nonwoven, and ACF cotton all improve the nonwoven performance of sound insulation. It seems that the cotton nonwoven and ACF cotton nonwoven show better transmission loss than glassfiber during the low frequency range from 350 to 1600 Hz. All three types of surface show no difference during the high frequency range from 1600 to 6400 Hz.

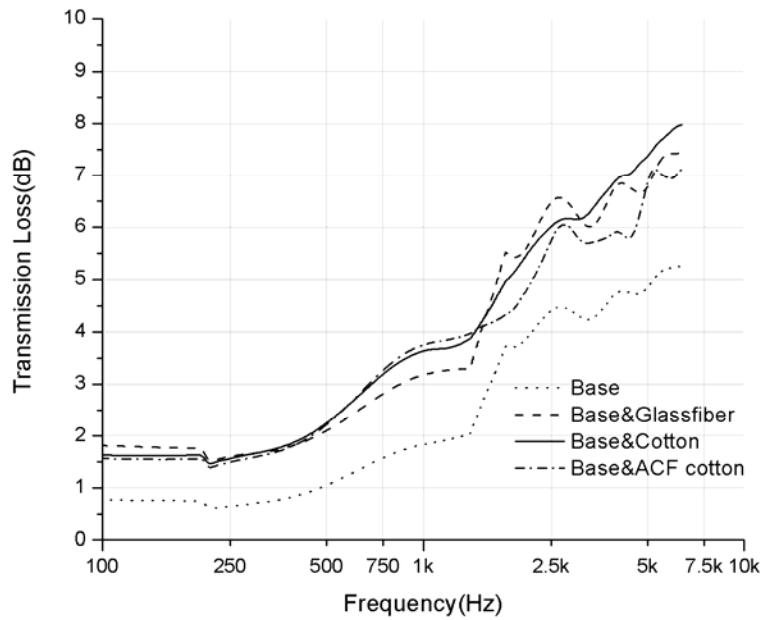

Figure 33 Transmission Loss of Nonwovens

Similar to the sound absorption, the average values of the transmission loss for all the nonwovens were defined by the following equation:

$$\overline{TL} = \frac{\int_{F_1}^{F_2} TL(f) df}{F_2 - F_1}, \quad (7)$$

where  $F_1$  is lower bound of sound frequency in testing and  $F_2$  is upper bound of sound frequency in measurement. The  $\overline{TL}$  values between  $F_1$  (100 Hz) and  $F_2$  (6400 Hz) for the acoustic nonwovens are listed in Table 10.

Table 10 Means of Transmission Loss ( $\overline{TL}$ )\*

	Base (dB)	Base&Glassfiber (dB)	Base&Cotton (dB)	Base&ACF cotton (dB)
1	3.170	4.170	6.031	5.224
2	3.315	6.611	5.685	5.630
3	4.144	6.229	5.859	5.354
Mean	3.543	5.670	5.858	5.436
Wilcoxon Sum Scores	6	27	27	18

\* Expected Wilcoxon Sum Scores under  $H_0$  is 19.5 ( $H_0$ : no difference among groups at  $\alpha=0.05$ ).

The  $\overline{TL}$  values for Base&Glassfiber and Base&Cotton rank first by Wilcoxon Sum Scores of nonparametric tests, and then followed by Base&ACF Cotton. The reason why the surface layers with cotton and glassfiber nonwovens show better sound insulation than the ACF cotton nonwovens is that sound TL mostly depends on the mass law. The sound TL mass law states that TL increases as the mass increases. As exhibited in Table 8, the cotton surface shows the highest average TL value because it has the highest mass per unit area ( $274\text{g/m}^2$ ) of the three surface layers.

#### 4.4 Conclusions

A carbonized and activated cotton nonwoven composite was produced and the experimental acoustical nonwovens were designed with a composite structure. The cotton nonwoven composites with three surface layers (glassfiber, cotton and ACF cotton) were evaluated in terms of their acoustic properties for sound absorption and sound insulation. The Brüel & Kjær impedance tube instrument was used for measuring the normal incidence sound absorption coefficient and transmission loss of the experimental composites at frequency range from 100 Hz to 6400 Hz.

The comparison of the sound properties was carried out using the statistical method of variance analysis. The results showed that the nonwoven composites with cotton as a surface layer had significantly higher sound absorption coefficients than the glassfiber-surfaced composite in the frequency range from 100 to 6400 Hz. Meanwhile, carbonization and activation of the cotton nonwoven improved sound absorption ability significantly. For the sound transmission loss, the transmission loss for Base&Glassfiber and Base&Cotton rank first, and then followed by Base&ACF Cotton. Considering the lightweight, biodegradability and low cost of the cotton raw material, the carbonized and activated cotton nonwoven has a potential to be used as high-performance and cost-effective acoustical materials.

#### 4.5 References

- Bacon, R. & Tang, M. M. 1964, "Carbonization of Cellulose Fibers .2. Physical Property Study", *Carbon*, vol. 2, no. 3, p. 221-&.
- Brown, P. N., Jayson, G. G., Thompson, G., & Wilkinson, M. C. 1987, "Adsorption Characteristics of Impregnated Activated-Charcoal Cloth for Hydrogen-Cyanide", *Journal of Colloid and Interface Science*, vol. 116, no. 1, pp. 211-220.
- Carrott, P. J. M. & Freeman, J. J. 1991, "Evolution of Micropore Structure of Activated-Charcoal Cloth", *Carbon*, vol. 29, no. 4-5, pp. 499-506.
- Ehrburger, P., Pusset, N., & Dziedzic, P. 1992, "Active Surface Area of Microporous Carbons", *Carbon*, vol. 30, no. 7, pp. 1105-1109.
- Freeman, J. J. & Gimblett, F. G. R. 1987, "Studies of Activated-Charcoal Cloth .2. Influence of Boron-Containing Impregnants on the Rate of Activation in Carbon-Dioxide Gas", *Carbon*, vol. 25, no. 4, pp. 565-568.
- Freeman, J. J. & Gimblett, F. G. R. 1988, "Studies of Activated-Charcoal Cloth .4. Influence of Phosphate Impregnants on the Rate of Activation in Carbon-Dioxide Gas", *Carbon*, vol. 26, no. 4, pp. 501-505.
- Freeman, J. J., Gimblett, F. G. R., Roberts, R. A., & Sing, K. S. W. 1987, "Studies of Activated-Charcoal Cloth .1. Modification of Adsorptive Properties by Impregnation with Boron-Containing Compounds", *Carbon*, vol. 25, no. 4, pp. 559-563.
- Freeman, J. J., Gimblett, F. G. R., Roberts, R. A., & Sing, K. S. W. 1988, "Studies of Activated-Charcoal Cloth .3. Mesopore Development Induced by Phosphate Impregnants", *Carbon*, vol. 26, no. 1, pp. 7-11.

- Freeman, J. J., Gimblett, F. G. R., & Sing, K. S. W. 1989, "Studies of Activated-Charcoal Cloth .5. Modification of Pore Structure by Impregnation with Certain Transition-Metal Salts and Oxo-Complexes", *Carbon*, vol. 27, no. 1, pp. 85-93.
- Huang, J. M., Wang, I. J., & Wang, C. H. 2002, "Scanning force microscopy studies of the surface structure of activated carbon fabric", *Textile Research Journal*, vol. 72, no. 2, pp. 140-146.
- Lou, C. W., Lin, J. H., & Su, K. H. 2005, "Recycling polyester and polypropylene nonwoven selvages to produce functional sound absorption composites", *Textile Research Journal*, vol. 75, no. 5, pp. 390-394.
- Shoshani, Y. & Yakubov, Y. 1999, "A model for calculating the noise absorption capacity of nonwoven fiber webs", *Textile Research Journal*, vol. 69, no. 7, pp. 519-526.
- Shoshani, Y. & Yakubov, Y. 2000a, "Generalization of Zwicker and Kosten theory for sound absorption in flexible porous media to the case of variable parameters", *Journal of Computational Acoustics*, vol. 8, no. 3, pp. 415-441.
- Shoshani, Y. & Yakubov, Y. 2000b, "Numerical assessment of maximal absorption coefficients for nonwoven fiberwebs", *Applied Acoustics*, vol. 59, no. 1, pp. 77-87.
- Shoshani, Y. Z. 1990, "Effect of Nonwoven Backings on the Noise Absorption Capacity of Tufted Carpets", *Textile Research Journal*, vol. 60, no. 8, pp. 452-456.
- Shoshani, Y. Z. & Wilding, M. A. 1991, "Effect of Pile Parameters on the Noise Absorption Capacity of Tufted Carpets", *Textile Research Journal*, vol. 61, no. 12, pp. 736-742.
- Smisek, M. & Cerny, S. 1970, *Active Carbon - Manufacture, Properties and Applications* Elsevier Publishing Company, New York.
- Starek, J., Zukal, A., & Rathousky, J. 1994, "Comparison of the Adsorption of Humic Acids from Aqueous Solutions on Active Carbon and Activated Charcoal Cloths", *Carbon*, vol. 32, no. 2, pp. 207-211.
- Tang, M. M. & Bacon, R. 1964, "Carbonization of Cellulose Fibers .1. Low Temperature Pyrolysis", *Carbon*, vol. 2, no. 3, p. 211-&.

## **Chapter 5 Conclusions and Future Work**

### **5.1 Conclusions**

In response to Louisiana's agriculture development for finding new options for cellulosic fibers use, this study addressed research in the area of advanced high-performance activated carbon fiber and fabrics. The overall purpose of this research was to develop multifunctional materials with high performance for chemical absorption, adsorption, and desorption, and for acoustic absorption and insulation using natural fiber nonwovens processed by carbonization and activation.

Concerning environmental and health problems associated with hazardous volatile gas emission today, activated carbon is an excellent adsorbent to solve these problems due to its special pore structures and high adsorption and desorption properties. Because textile materials are easier to handle than the powdery form of carbon materials, end-use applications of active carbon fiber materials have wide applications in many industrial sectors. The nature of fiber enables them to be processed prior to carbonization and activation to produce pre-formed structures. The nonwoven is made from cellulosic fibers using the nonwoven techniques of carding and needle-punching prior to carbonization and activation in a gas tight oven with controlled temperature and gas flow. Such treated nonwoven structures can produce activated carbon web materials.

From previous studies, major fiber precursors for producing commercial activated carbon fibers (ACF) fabrics include rayon, acrylic, polyacrylonitrile (PAN), and Novoloid (novolac resin). This study demonstrated the possibility to manufacture a nonwoven fabric material made from cellulose-based cotton fibers because of their low cost, sustainability and biodegradability. Evaluation of these textile materials included mechanical properties, thermal properties (thermogravimetric analysis), acoustical properties (absorption and transmission loss),

microporous surface structure (Scanning Electronic Microscopy) and surface properties (surface area, micropore volume, micropore size distribution).

Carbonization of cotton nonwoven was carried out in a high temperature clean room oven purged with nitrogen between 300°C and 500°C to get the initial data. The activation of the carbonized nonwovens was undertaken using CO<sub>2</sub>. TGA results showed that at 346°C cellulose was pyrolyzed quickly and the ultimate weight loss was around 90%. Mechanical properties tested by Instron machine showed that although the nonwoven tensile strength was reduced significantly due to the carbonization and activation, the ACF cotton nonwoven still kept a good web form. The N<sub>2</sub> adsorption isotherm curves of the cotton nonwoven under different carbonization temperature showed the presence of micropores and macropores. High BET surface area and average pore diameters closed to micropores were obtained. The comparison between the N<sub>2</sub> and CO<sub>2</sub> adsorption showed that BET surface area for N<sub>2</sub> adsorption was much smaller than that for CO<sub>2</sub> adsorption and median pore width for the N<sub>2</sub> adsorption was greater than that for CO<sub>2</sub> adsorption due to the activated diffusion effects. The combination of adsorption isotherms of N<sub>2</sub> and CO<sub>2</sub> are recommended and the isotherms could provide complementary information in terms of micro-porosity, meso-porosity and macro-porosity in activated carbons.

A focused study was done with an aim at how to optimize the method of carbonizing and activating cotton nonwovens in order to further increase the surface area. Carbonization and physical activation of the cotton and rayon nonwoven samples were carried out in a vacuumed horizontal glass tube with N<sub>2</sub> and CO<sub>2</sub>, which could provide higher temperature up to 1200°C and more accurate control of all the parameters than the vacuum oven. ACF made from rayon fabrics showed slightly higher surface area than cotton. Longer heating time also contributed to high surface area. Surface area of 879.05 m<sup>2</sup>/g and BJH average diameter of 27.67 Å were

achieved when rayon was carbonized and activated at 800 °C for 4 hours. Cotton could endure longer heating time up to 5 hours at 800 °C than rayon and the surface area of cotton ACF is as high as 982.10 m<sup>2</sup>/g. Chemical activation method was also investigated by impregnation of cotton fabric with ZnCl<sub>2</sub>, which modified the pyrolysis process by increasing final ACF yield, surface area and developing micropores. This study demonstrated that activated carbon fiber can be prepared from cotton nonwoven fabrics with high adsorption capacity and microporosity based on temperature around 800 °C and heating time of four hours.

A new acoustic application for activated carbon fiber nonwoven from cotton nonwoven fabric was proposed. A nonwoven composite of ACF with cotton nonwoven as a base layer was developed. Also produced were the composites of the cotton nonwoven base layer with a layer of glassfiber nonwoven, and the cotton nonwoven base layer with a layer of cotton fiber nonwoven. Their noise absorption coefficients and sound transmission loss were measured using the Bruel & Kjaer impedance tube instrument. The study concluded that the ACF composite exhibited a greater ability to absorb normal incidence sound waves than the composites with either glassfiber or cotton fiber. The analysis of sound transmission loss revealed that the three composites still obeyed the mass law of transmission loss. The composite with the surface layer of cotton fiber nonwoven possessed a higher fabric density and therefore showed a better sound insulation than the composites with glassfiber and ACF. Thus, the ACF composite exhibits a great sound absorption and sound insulation properties.

In summary, this research explored the optimum treatment temperature and time for carbonizing and activating rayon and cotton nonwovens. It also demonstrates that the carbonized and activated cotton nonwovens are a special type of biobased material that featured with lightweight, good surface properties, and high performance for chemical adsorption and acoustic application.

## 5.2 Future Work

Because of time limit, the research work accomplished in this project was still in initial stage. The following technical issues remain unsolved and need further research efforts.

First issue is ACF nonwoven strength. Although the ACF nonwovens kept in a good web form after carbonization and activation, the tensile strength of both cross-machine and along-machine directions decreased dramatically. Further research is needed with an emphasis on how to increase tensile strength in order to increase their use potential in industries. Some specialty fibers e.g. Nomex, carbon fiber, metal fiber or ceramic fiber that can endure high temperature could be blended with cotton or rayon fibers in nonwoven manufacturing step. The mechanical strength of the nonwovens could also be enhanced by increasing the density of the nonwovens. For example, the nonwoven samples could be processed in the needle-punching machine many times.

Secondly, to compete with the commercial ACF manufactured from synthetic fibers with surface area of more than 1500 m<sup>2</sup>/g, the surface area of activated carbon nonwovens from renewable cellulosic fibers such as cotton and rayon need to be further increased. As it has been shown in Chapter 3, chemical activation with ZnCl<sub>2</sub> improved the surface area significantly. More studies could be done on the effects of different chemical agents, concentration of chemical solutions and soaking time to increase the surface area. Chemical activation is also a good way to increase the yields for the activated carbon fiber fabrics to be used as cost-effective materials.

Third issue is to control some more parameters during carbonization and activation. In this study, treatment time and temperature were already discussed. The effects of heating rate and gas flow rate also need to be explored to improve the surface properties of the final products in the future.

Finally, precursors from fresh biomass origin offer the most economical source because they are renewable supplies, with low mineral content and appreciable hardness, and of low cost. The raw materials of carbonization and activation could extend to other nature cellulosic fibers such as kenaf, hemp and linen.

## Appendix: Permission Letter

**From:** "Lehane, Clare (ELS)" <C.Lehane@elsevier.com>  
**To:** "Nan Jiang" <njiang2@lsu.edu>  
**CC:**  
**Subject:** RE: request for a permission letter  
**Date:** 2008年11月4日 2:45:09 Tue, 4 Nov 2008 08:45:09 -0000

Dear Nan,

If you are the author of the below paper, then you do not need Elsevier's permission to put it into your dissertation. Just make sure that you have the correct reference for your paper at the beginning of the chapter.

Best wishes,

Clare

Clare Lehane, PhD,  
Publishing Editor, Energy, Elsevier  
The Boulevard, Langford Lane, Kidlington, Oxford OX5 1 GB  
[c.lehane@elsevier.com](mailto:c.lehane@elsevier.com)

Elsevier Limited. Registered Office:  
The Boulevard, Langford Lane,  
Kidlington, Oxford, OX5 1GB,  
United Kingdom, Registration No. 1982084  
(England and Wales).

-----Original Message-----

From: Nan Jiang [mailto:[njiang2@lsu.edu](mailto:njiang2@lsu.edu)]  
Sent: 04 November 2008 03:24  
To: Lehane, Clare (ELS)  
Subject: request for a permission letter

Dear editor,

I am writing to you to request for a permission letter of an accepted paper to be included in my dissertation. The manuscript entitled "Acoustical evaluation of carbonized and activated cotton nonwovens" which was assigned reference number BRT 08-54 in the journal Bioresource Technology.

I would be much appreciated if you reply me as soon as possible and give me the permission since the deadline of dissertation submission is around the corner.

Thank you so much.

Regards,

Nan Jiang  
MS Student in Statistics  
Ph.D. Student in Textile Science  
Research Assistant  
School of Human Ecology  
Louisiana State University  
Baton Rouge, LA 70803  
Office#(225)578-1723

## VITA

Nan Jiang was born in June 1979, in Nanjing, China. She attended Wuxi University of Light Industries, China, in September of 1997. There she received her Bachelor Degree in Chemical Engineering & Technology in 2001 and Master Degree in Applied Chemistry in 2004. Ms. Jiang will graduate with the degree of Doctor of Philosophy in human ecology from Louisiana State University in December 2008. In addition, Ms. Jiang enrolled in a master's program of applied statistics at Louisiana State University and will also earn that degree in December 2008.