

**SYNTHESIS AND PROPERTIES OF NOVEL MACROCYCLES AND RELATED
CHROMOPHORIC BENZENOID COMPOUNDS**

A Dissertation

Submitted to the Graduate Faculty of the
Louisiana State University and
Agricultural and Mechanical College
in partial fulfillment of the
requirements for the degree of
Doctor of Philosophy

In

The Department of Chemistry

By

Jorge O. Escobedo Cordova
B.S., Universidad Autónoma de Nuevo León, México
M.S., Universidad Autónoma de Nuevo León, México
December 2002

DEDICATION

I dedicate this dissertation to my family. First of all, to my father Héctor Escobedo López, who passed away during last year's Christmas, and to my mother Cayetana Córdova Cruz. Thank you for giving me life, love, education and the freedom to make decisions. Next, to my beloved wife Martha Sibrian Vazquez and to our daughter Jessica. Martha, you are wonderful, thank you for your love and support and for sharing your life with me. Jessica, thanks for being with me bringing joy and happiness; I love you very much. Finally, to my brothers Juan José (Pelón), Héctor (Chacho), Leopoldo Rafael (Rafles) and my sisters Mireya (Gorda), Nora Leticia (Tejón), Elvia Tania (La Nena), Rocío (Pijei), Claudia Marithza, my uncles, aunts, cousins, nephews and other relatives. Thanks for your help and advice; I love you all.

ACKNOWLEDGMENTS

First of all, I would like to give my deepest and sincerest thanks to my research advisor, Dr. Robert Strongin, for affording me the opportunity to work in his group and guiding me in my research. Thank you for all the brainstorms we had and for showing me how to work hard enough to achieve my goals. I would like to give my special thanks to Dr. Mark Read for his great help in my research as well as being a good friend. My thanks also go to my colleagues and friends Ming He and David Amspacher. Thank you for your friendship and for all your unselfish and timely help. To my former colleagues Dr. Alfonso Dávila, Dr. Larry Cabell, Claude Davis, Dr. Taiya Fabre, Dr. Patrick Lewis, Dr. Douglas Willis and Patricia A. Beck, I thank you all for the help you offered to me in my research. My thanks also go to my current colleagues Nadia St. Luce, Rolanda J. Johnson, Latisha C. Johnson and Kyu Kwang Kim for their help in my research work. I would also like to give my thanks to Dr. Rafael Cueto, Dr. Frank Fronczek, Dr. W. Dale Treleaven, Dr. Frank Zhou, Dr. George Stanley and Dr. Mark McLaughlin for their advice. I'd like to thank our undergraduate students Kenneth Hebert, Walter Comeaux, Marcus Dillon and Amy E. Frey. Finally, I would like to thank Dr. Robert Hammer, Dr. William Crowe, Dr. William Daly and Dr. Joseph Taboada for their help on my research and for being my research committee members. I also want to thank the generous support of the Fulbright Program and CONACyT.

TABLE OF CONTENTS

| | |
|---|-----|
| DEDICATION..... | ii |
| ACKNOWLEDGMENTS..... | iii |
| LIST OF TABLES..... | vi |
| LIST OF FIGURES..... | vii |
| LIST OF SCHEMES..... | ix |
| LIST OF ABBREVIATIONS..... | x |
| ABSTRACT..... | xii |
| CHAPTER 1. A POST-COLUMN DETECTION SYSTEM FOR MONO- AND OLIGOSACCHARIDES BASED ON SELECTIVE CHROMOPHORIC RECEPTORS..... | 1 |
| 1.1 Introduction..... | 1 |
| 1.2 Design of a Post-Column Reactor System..... | 3 |
| 1.3 Experimental Section..... | 4 |
| 1.4 Results and Discussion..... | 5 |
| 1.5 Conclusion and Future Work..... | 6 |
| 1.6 References..... | 6 |
| CHAPTER 2. SYNTHESIS OF OLIGOPHENYLENES AND RELATED MATERIALS..... | 7 |
| 2.1 Introduction..... | 7 |
| 2.2 Specific Goals..... | 10 |
| 2.3 Synthesis of the Oligo- <i>p</i> -phenylenes Building Block..... | 10 |
| 2.4 Synthesis of Octomeric <i>p</i> -phenylene..... | 11 |
| 2.5 Synthesis of Oligo- <i>p</i> -phenylenes with Long Aliphatic Chain Attached... | 12 |
| 2.6 Coupling of Oligo- <i>p</i> -phenylenes with Resorcinarene..... | 15 |
| 2.7 Conclusions and Future Work..... | 17 |
| 2.8 Experimental Section..... | 17 |
| 2.9 References..... | 24 |
| CHAPTER 3. CONVENIENT SYNTHESIS AND SINGLE-CRYSTAL X-RAY STRUCTURES OF TWO TETRAFLUORO[2,2]PARACYCLOPHANE ISOMERS..... | 28 |
| 3.1 Introduction | 28 |
| 3.2 Discussion..... | 29 |
| 3.3 Experimental Section..... | 31 |
| 3.4 References..... | 33 |

| | |
|--|----|
| CHAPTER 4. AN UNUSUAL SEVEN-BOND H-H SPIN COUPLING..... | 34 |
| 4.1 Introduction..... | 34 |
| 4.2 Background..... | 35 |
| 4.3 Molecular Modeling..... | 39 |
| 4.4 References | 41 |
| CHAPTER 5. CHROMOPHORE FORMATION IN RESORCINARENE SOLUTIONS | 42 |
| 5.1 Introduction..... | 42 |
| 5.2 Background..... | 42 |
| 5.3 The Formation and Structure of the Chromophore in Resorcinarene Solutions..... | 44 |
| 5.4 Evidence for Acid Formation in DMSO Solutions..... | 49 |
| 5.5 Macrocycle Bond Breaking and Oxidation of the Acyclic Products..... | 50 |
| 5.6 Conclusion..... | 55 |
| 5.7 Experimental Section..... | 55 |
| 5.8 References..... | 57 |
| CHAPTER 6. INVESTIGATION OF THE [60]FULLERENE PHOTOOXIDATION REACTION FOR THE PRESENCE OF THE [5,6]-OPEN OXIDOANNULENE C ₆₀ O ISOMER..... | 60 |
| 6.1 Introduction..... | 60 |
| 6.2 Results and Discussion..... | 61 |
| 6.3 Conclusion..... | 64 |
| 6.4 References..... | 64 |
| APPENDIX A: ¹ H NMR OF OLIGOPHENYLENES..... | 66 |
| APPENDIX B: CHARACTERIZATION DATA FOR COMPOUND 3.3b | 71 |
| APPENDIX C: LETTERS OF PERMISSION..... | 89 |
| VITA..... | 92 |

LIST OF TABLES

| | | |
|-----|---|----|
| 5.1 | MALDI MS Evidence for the Formation of Acyclic Oxidized and Unoxidized Products from the Thermolysis of 5.2b | 53 |
|-----|---|----|

LIST OF FIGURES

| | | |
|-----|--|----|
| 1.1 | Compound 1.1 | 3 |
| 1.2 | Diagram of a typical post-column chromatographic set-up..... | 4 |
| 1.3 | Analysis of a mixture of 20 μg of D-glucose (r.t.=9.5 min) and 20 μg of D-fructose (r.t.=11.33 min). Note the better response for D-fructose..... | 5 |
| 2.1 | Design of a Molecular Scaffold 2.1 | 9 |
| 2.2 | Energy Minimized Structure of compound 2.2 ($n = 4$) and Doxorubicin (spacefill representation)..... | 10 |
| 3.1 | Structures of [2,2]- <i>p</i> -cyclophane (3.1) and its fluorinated derivatives..... | 29 |
| 3.2 | X-ray Structures of 3.3a and 3.3b | 31 |
| 4.1 | Structures and numbering system of the alkaloids tiliacorinine (4.1), tiliacorine (4.2) and tiliamosine (4.3)..... | 35 |
| 4.2 | Expansion of the DQF-COSY and NOESY spectra (CDCl_3 , 25 $^\circ\text{C}$, NOESY mix time 0.5 sec) of 4.1 | 36 |
| 4.3 | Energy-minimized structure of tiliacorinine (4.1) showing bent bonds before geometry optimization..... | 40 |
| 4.4 | Energy-minimized structure of tiliacorinine (4.1) after geometry optimization showing the distances in angstroms among the protons on rings C, D, E and F. Note the short distance between H-8' and H-10' of 1.84 Å | 40 |
| 5.1 | Resorcinarenes and related condensation products that produce color changes in the presence of sugars..... | 43 |
| 5.2 | Xanthene dyes 5.6a and 5.6b | 45 |
| 5.3 | 5.2a (1.0 mg) and 5.3a (1.0 mg) each in 0.9 mL DMSO were heated to gentle reflux over two minutes and cooled to room temperature before 0.1 mL H_2O was added to each solution. The final concentrations of 5.2a and 5.3a in 9:1 DMSO: H_2O are 1.03×10^{-3} M and 1.96×10^{-3} M respectively. A solution of 5.6b (5.0×10^{-6} M) was prepared at rt in 9:1 DMSO: H_2O | 46 |
| 5.4 | Energy-minimized structure (SYBYL [®] 6.6) of a hypothetical macrocyclic xanthene derived from 5.2b | 47 |

| | | |
|------|---|----|
| 5.5 | Chromatogram of a reaction of resorcinol (r.t.=13.5 min) and acetaldehyde quenched after 10 min according with the procedure reported by Weinelt and Schneider ^{5,18} showing the formation of 5.3b (r.t.=18 min)..... | 48 |
| 5.6 | Compound 5.7 and ORTEP..... | 50 |
| 5.7 | (A) Chromatogram of 5.2b (Control) (B) Chromatogram of the thermolysis products of 5.2b showing also the formation of 5.3b | 51 |
| 5.8 | Top: expansion of a ¹ H NMR spectrum of semipurified thermolysis reaction products of 5.2b showing the formation of 5.3b . Bottom: expansion of a ¹ H NMR spectrum of pure 5.3b | 52 |
| 5.9 | 2',4'-Dihydroxyacetophenone (5.8) formed upon oxidation of a DMSO solution of 5.3b | 53 |
| 5.10 | ¹ H NMR of the products of oxidation of 5.3b showing the formation of 5.6a (as its tautomer)..... | 54 |
| 6.1 | Structures of the two possible isomers of C ₆₀ O: epoxide (6.1) and oxidoannulene (6.2)..... | 60 |
| 6.2 | HPLC traces: a prepared mixture of [60]fullerene, 6.1 and 6.2 (top), the crude reaction mixture obtained via the photolysis of [60]fullerene in an O ₂ -saturated benzene solution containing benzil (middle) and recycled epoxide 6.1 early-eluting fractions from the [60]fullerene photolysis reaction (bottom)..... | 63 |

LIST OF SCHEMES

| | | |
|-----|--|----|
| 2.1 | Extension of the lower rim of a macrocyclic resorcinarene | 8 |
| 2.2 | Synthesis of 2.5 which was used as a building block in the synthesis of <i>p</i> -oligophenylenes..... | 11 |
| 2.3 | Molecular Doubling. Specific functionalization of 2.6 to make 2.7 and 2.8 that can couple together to obtain tetramer 2.9 | 12 |
| 2.4 | Compound 2.12 couldn't be synthesized from the functionalized tetramers..... | 13 |
| 2.5 | The lauroyl amide of the building block 2.6 | 14 |
| 2.6 | Synthesis of octamer 2.16 | 14 |
| 2.7 | Coupling of resorcinarene 2.17 with oligophenylenes 2.6 and 2.9 | 15 |
| 2.8 | Coupling of oligophenylenes 2.13 and 2.14 with 4-formylphenylboronic acid.... | 15 |
| 2.9 | Condensation of compound 2.18 with resorcinol..... | 16 |
| 3.1 | Conversion of known tetrabromides 3.4a and 3.4b to the fluorinated targets 3.3a and 3.3b in a 2:3 ratio..... | 30 |
| 5.1 | Dehydration and oxidation of methine-bridged resorcinol oligomers leading to a xanthene..... | 45 |
| 5.2 | Diagram of the reaction of paraldehyde and resorcinol showing the reversible formation of a variety of intermediates in acidic media including acyclic oligomers and resorcinarenes as reported by Weinelt and Schneider (compound 5.3b is labeled as A). ^{5.18} | 48 |

LIST OF ABBREVIATIONS

| | |
|-----------------|---|
| amu | Atomic Mass Units |
| BHT | Butylated hydroxytoluene, 2,6-Di- <i>tert</i> -butyl-4-methylphenol |
| °C | Degrees Celsius |
| calcd | Calculated |
| COSY | Correlated Spectroscopy |
| DCC | 1,3-Dicyclohexylcarbodiimide |
| DCM | Dichloromethane |
| DMAP | 4-Dimethylaminopyridine |
| DMF | <i>N,N</i> -Dimethylformamide |
| DMSO | Dimethyl sulfoxide |
| dppf | Diphenylphosphinoferrocene |
| DQF-COSY | Double Quantum Filtered Correlated Spectroscopy |
| ELSD | Evaporative Light Scattering Detection |
| FAB | Fast Atom Bombardment |
| FSAU | Full-Scale Absorbance Units |
| FT-IR | Fourier Transform Infrared |
| g | Grams |
| h | Hours |
| HOBT | 1-Hydroxybenzotriazole |
| HPLC | High-Performance Liquid Chromatography |
| HRMS | High-Resolution Mass Spectrometry |
| <i>M</i> | Molar (moles/Liter) |

| | |
|----------------------|---|
| MALDI | Matrix-Assisted Laser Desorption Ionization |
| MCPBA | <i>m</i> -chloroperoxybenzoic acid |
| MeOH | Methanol |
| mg | Milligrams |
| mL | Milliliters |
| mmol | Millimoles |
| MS | Mass Spectrometry |
| NMR | Nuclear Magnetic Resonance |
| NOESY | Nuclear Overhauser Effect Spectroscopy |
| PAD | Pulsed Amperometric Detection |
| ppm | Parts Per Million |
| PPV | Poly(<i>p</i> -phenylenevinylene) |
| R_F | Ratio to Solvent Front |
| r.t. | Retention Time |
| rt | Room Temperature |
| THF | Tetrahydrofuran |
| TLC | Thin-Layer Chromatography |
| UV | Ultraviolet |
| UV-vis | Ultraviolet-Visible |
| λ | Wavelength |

ABSTRACT

The synthesis and properties of some macrocyclic compounds of interest are presented. Resorcinarenes with functionalized conjugated rigid rods made of oligo-*p*-phenylenes would lead to an entirely new class of functional, soluble, well-defined architectures impacting a variety of multidisciplinary research efforts. The general synthetic design described in this document could be readily extrapolated to include other electronic systems such as heteroaromatics and polyenes.

An extensive collaborative study of chromophore formation in resorcinarene solutions is also described here. The study reveals that upon oxidation, the reversible conversion to acyclic precursors occur first, and then these precursors undergo oxidation to quinoid-type compounds (xanthenes). The understanding of the mechanism of chromophore formation allowed us to design selective receptors for carbohydrates and the development of post-column selective reagents for the detection of mono- and oligosaccharides. This latter work is still in progress and the preliminary studies are described here.

In another study involving macrocyclic architectures, tiliacorinine, an alkaloid, which consists of five rings forming a macrocycle exhibits a rare H-H spin coupling in its ^1H NMR. Molecular modeling was used to determine the spatial relationship between the protons involved.

Fluorinated [2,2]*p*-cyclophanes have been attracting increased attention. Poly(*p*-xylylene) polymers are materials of current technological interest. An obstacle to the commercialization of these polymers is the multistep syntheses required to obtain the

fluorinated monomers. We describe a two-step synthesis of the tetrafluoro[2,2]*p*-cyclophanes.

Another family of compounds, the fullerenes, was studied. Authors of a recent communication about the isolation and characterization of what was called the “missing” isomer of C₆₀O postulated that this isomer could be present during the epoxidation of C₆₀. Our HPLC and ¹H NMR studies of the epoxidation of C₆₀ revealed that there is no other isomer besides the epoxide in the photooxygenation of C₆₀.

CHAPTER 1

A POST-COLUMN DETECTION SYSTEM FOR MONO- AND OLIGOSACCHARIDES BASED ON SELECTIVE CHROMOPHORIC RECEPTORS

1.1 Introduction.

The analysis of saccharides by HPLC is very useful.^{1.1} In general, carbohydrates cannot be detected by absorption in the ultraviolet and visible regions or by fluorescence, because they lack chromophores or fluorophores.^{1.1b} They can be detected by measuring refractivity, but this method is not sensitive enough to detect samples of less than 10 nmol and, in addition, this method can be affected considerably by changes in temperature and solvent composition.^{1.1b} Because of the above reasons, refractivity detection is usually limited to isocratic chromatography.^{1.1b} UV detection below 210 nm limits solvent choice and necessitates ultrapure solvents. Electrochemical detection by pulsed amperometric detection (PAD) requires high pH conditions. Mass spectrometry, coupled with chromatographic separations, requires specialized, expensive equipment. Aromatic or heterocyclic substituents are often used as chromogenic labels to enable the UV detection of oligosaccharides; however, this requires sample preparation and can affect separation adversely. Radioactive labeling has also been used for radioactivity monitoring but involves the handling of radioactive materials.^{1.6} In the past decade, a new development towards post-column detection of oligosaccharides was the advent of evaporative light scattering detection (ELSD). A main advantage is that it operates independent of molecular chromophores and does not require the construction of calibration curves. This method does have drawbacks, however. If one is analyzing molecules with a lower molecular weight range that have the potential to evaporate along

with the mobile phase, then detector design is a major issue. Buffer choice is also limited to only a few salts due to evaporation with the mobile phase. The system is also expensive and requires relatively high maintenance.^{1.1c}

For the detection of carbohydrates, much effort has been made to develop methods for derivatization to photometrically or fluorometrically detectable forms. Post-column derivatization has attracted the attention of carbohydrate analysis. In the beginning, detection systems based on a specific post-column reaction of sugars were the first ones used in the automated liquid chromatography of these compounds. However, these detection reagents based on the use of strong acids^{1.2} are difficult to handle, require a specially designed acid-resistant reagent delivery and detection system, cause excessive peak broadening and are incompatible with some solvents such as acetonitrile.^{1.5} Recently, the development of much milder reactions with fluorogens has been made; for example, Mopper et. al.^{1.3} reported the detection of mono- and oligosaccharides by post-column derivatization with ethylenediamine in 0.05-0.8 M borate buffer (pH = 7.0–10.5).

The reagents used in post-column derivatization are selective for a family of compounds (for instance, aldoses, ketoses, uronic acids, aminosugars, etc.). The development of potentially selective receptors that can be used as post-column derivatization reagents can speed up the analysis of one component and allow the use of less specialized columns, by reducing the number of signals. In this work the analysis of D-fructose in the presence of other monosaccharides and the detection of oligosaccharides are evaluated using compounds **1.1**^{1.8} (Figure 1.1) and **5.2a**.^{1.9}

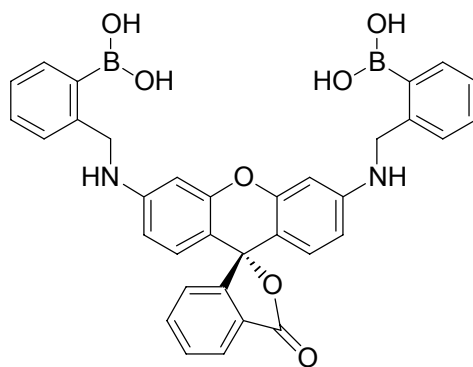

1.1

Figure 1.1 Compound 1.1

1.2 Design of a Post-Column Reactor System.

Post-column derivatization requires reaction after separation, but it should be made before detection. The appropriate reaction time at the desired temperature can be reached by controlling the dimensions of the reaction tube, flow-rate of the effluent and heating block temperature. Continuous mixing of a flow of a reagent solution followed by reaction for an appropriate length of time at a suitable temperature by passing the mixed effluent through a reaction tube placed in a thermostated heating block, converts the components of the sample into detectable derivatives, which are successively led to a detector.

Another aspect is that this process is naturally automatic, since separated carbohydrates and a reagent are supplied in steady streams and the products formed after reaction in the combined stream are transported to a detector cell by a pressurized flow by either a pump equipped with a pulse damper or a pneumatic delivery system. A general diagram of a HPLC post-column derivatization system is shown in Figure 1.2.

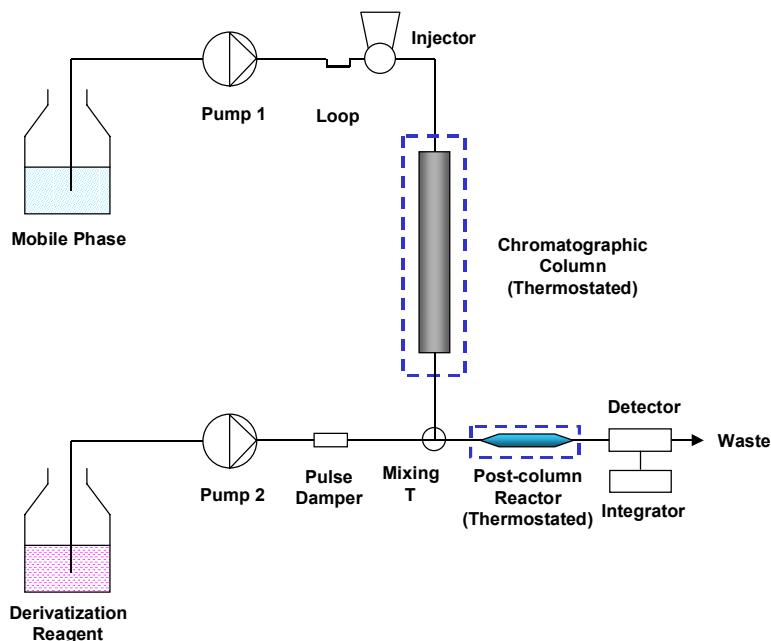

Figure 1.2. Diagram of a typical post-column chromatographic set-up

1.3 Experimental Section.

HPLC experiments were performed on a CM4000 multiple solvent delivery system (LDC/Milton Roy) and a SpectroMonitor 3100 UV-vis detector (LDC/Milton Roy) using an Alltech 700CH carbohydrate column (6.5 mm ID x 30 cm L) with a flow rate of 0.5 mL/min at a constant temperature of 85 °C.

The Post-column detection system consisted of a Helium Cylinder connected to a Timberline[®] RDR-1 Reagent Delivery/Reaction Module. The RDR-1 unit contains a pressurized reagent reservoir, a mixing tee, and a thermostated reaction block with a Teflon[®] reaction coil (0.02 in I.D. x 1 m L) with a nominal volume of 0.2 mL. The HPLC column was attached to the RDR-1. The RDR-1 was attached to a SpectroMonitor 3100 UV-vis detector (LDC/Milton Roy).

1.4 Results and Discussion.

The RDR-1 reagent delivery-reactor module was chosen because it consists of a single module for reagent storage, reagent delivery, mixing of reagent and the components that come from the HPLC column and also provides a reactor. The other reason for choosing the RDR-1 module was that pneumatic delivery of reagent would not contribute as another source for pulsations, as in the case of a second pump system. The Alltech 700CH carbohydrate column was chosen because it requires just deionized water as the mobile phase.

Mixtures of D-glucose and D-fructose were injected at different ratios. When a mixture of 20 μg of each sugar with compound **1.1** was injected, D-fructose exhibited a higher response compared with D-glucose (Figure 1.3). A recent study by Aliani and Farmer^{1.4} used tetrazolium blue as reagent in a post-column detection system for reducing and phosphorylated sugars. They reported a detection limit of 14.3 μg for D-fructose. The result observed in the chromatogram where compound **1.1** is used suggests that reaching a lower detection limit for D-fructose is possible.

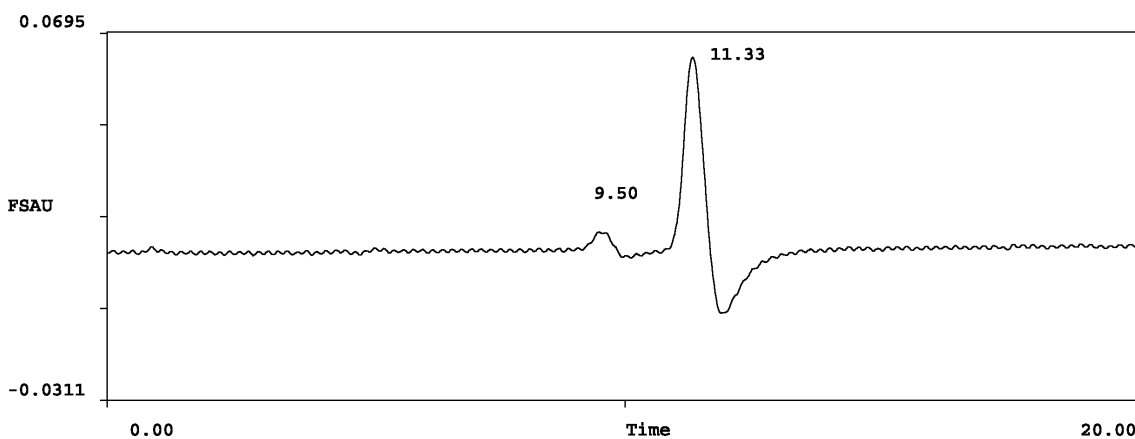

Figure 1.3. Analysis of a mixture of 20 μg of D-glucose (r.t.=9.5 min) and 20 μg of D-fructose (r.t.=11.33 min). Note the better response for D-fructose.

1.5 Conclusion and Future Work.

At the present time, and after the promising results obtained in the first attempts, the optimization of the conditions for the selective detection of fructose is in progress, as well as the post-column detection of oligosaccharides based on the results obtained by C. Davis and P. Lewis^{1,7} using compound **5.2a**.

Pulsations generated by the pump that delivers the mobile phase led to instability of the baseline. Better results are expected after the pump gets fixed.

1.6 References.

- 1.1 For reviews about detection and post-column derivatization of carbohydrates see: (a) Honda, S. *J. Chromatogr. A*, **1996**, *720*, 183. (b) Honda, S. *Anal. Biochem.* **1984**, *140*, 1. (c) Herbreteau, B. *Analisis* **1992**, *10*, 355.
- 1.2 Kesler, P. B. *Anal. Chem.* **1967**, *39*, 1416.
- 1.3 Mopper, K.; Dawson, R.; Liebezeit, G.; Hansen, H.-P. *Anal. Chem.* **1980**, *52*, 2018.
- 1.4 Aliani, M.; Farmer, L. J. *J. Agric. Food Chem.* **2002**, *50*, 2760.
- 1.5 Vrátný, P.; Brinkman, U. A. Th.; Frei, R. W. *Anal. Chem.* **1985**, *57*, 224
- 1.6 Kennedy, J. F.; Pagliuca, G. "Oligosaccharides," in *Carbohydrate Analysis. A Practical Approach* Chaplin M. F.; Kennedy, J. F., Eds., Oxford University Press, Oxford, 1994, p. 44-72.
- 1.7 He, M.; Johnson, R. J.; Escobedo, J. O.; Beck, P. A.; Kwang, K. K.; St. Luce, N. N.; Davis, C. J.; Lewis, P. T.; Fronczek, F. R.; Melancon, B. J.; Mrse, A. A.; Treleaven, W. D.; Strongin, R. M. "The Mechanism of Chromophore Formation in Resorcinarene Solutions and Visual Detection of Mono- and Oligosaccharides" *J. Am. Chem. Soc.*, **2002**, *124*(18), 5000.
- 1.8 Compound **1.1** has been synthesized by K. K. Kim. *Thesis in preparation*.
- 1.9 Lewis, P. T.; Davis, C. J.; Saraiva, M.; Treleaven, W. D.; McCarley, T. D.; Strongin, R. M. *J. Org. Chem.* **1997**, *62*, 6110.

CHAPTER 2

SYNTHESIS OF OLIGOPHENYLENES AND RELATED MATERIALS*

2.1 Introduction

The resorcinarenes, cyclic aromatic tetramers made from the condensation of resorcinol and aldehydes, have been extensively studied.^{2.1} The potential use of these compounds as catalysts, chemosensors^{2.1d} and drug delivery agents, has been investigated or proposed.^{2.1c} Research involving resorcinarene molecular containers has resulted in landmark achievements including the stabilization of encapsulated cyclobutadiene^{2.2a} and benzyne.^{2.2b}

The properties of resorcinarenes can be enhanced by functionalization of its lower rim.^{2.3, 2.4} In 1989 there was a report describing the extension of the resorcinarene lower cavity conjugation, involving a multistep process to incorporate a phenylacetylene moiety.^{2.2a} The Strongin research group (Scheme 2.1) has reported a direct, fourfold conjugation extension of the lower rim.^{2.14} This findings should significantly broaden the scope and utility of the resorcinarenes. They would allow for the creation of rigid, heteropolyfunctional, directional molecular scaffolds. They should result in the construction of new heteropolytopic receptors and unique supramolecular materials.

Conjugated rigid rods have attracted worldwide attention in polymer and materials chemistry and physics.

*Reprinted in part with permission from *Organic Letters*, 2000, Volume 2, No. 20, pages 3201-3204; Mark W. Read, Jorge O. Escobedo, Douglas M. Willis, Patricia A. Beck, and Robert M. Strongin; Convenient Iterative Synthesis of an Octameric Tetracarboxylate-Functionalized Oligophenylene Rod with Divergent End Groups. Copyright 2000 American Chemical Society.

They possess a variety of optical and electronic properties^{2.5} which have potential for use in nonlinear optical,^{2.6} sensory^{2.7} and luminescent devices.^{2.8}

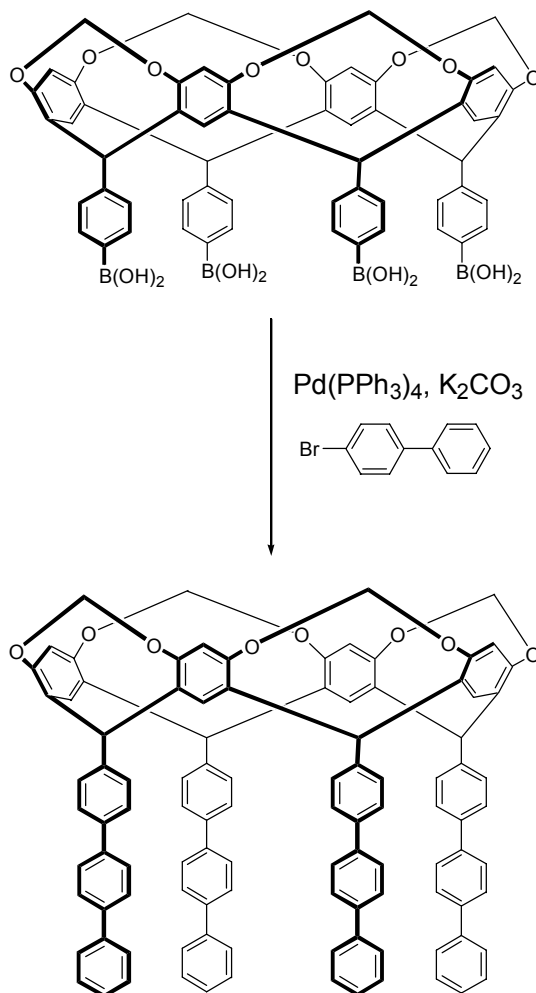

Scheme 2.1 Extension of the lower rim of a macrocyclic resorcinarene.

Poly(*p*-phenylenes) and related oligomers have exhibited a variety of properties including high mechanical strength, radiation and chemical resistance, luminescence, paramagnetism and electrical conductivity.^{2.10} There has been much research on the synthesis of soluble poly(*p*-phenylenes) of defined morphology.^{2.9, 2.11} Iterative molecular doubling approaches have been used to directly control the dispersity of rigid rod conjugated materials.^{2.12}

One example describes the synthesis of oligo(*p*-phenylenes) up to the 16-mer.^{2.13} The approach used in my project is similar but includes important departures including the synthesis of materials with side group functions that are polar and reactive. This not only would enable control over solubility, but also affords versatile sites to promote covalent and noncovalent interactions.

Resorcinarenes with conjugated rigid rods attached at the lower rim (Figure 2.1) should constitute a fundamental advance. The construction of these materials would eventually lead to an entirely new class of functional, soluble, well-defined three-dimensional architectures impacting a variety of multidisciplinary research efforts. The general synthetic design applied for constructing this architectures could be readily extrapolated to include other electronic systems such as heteroaromatics and polyenes.

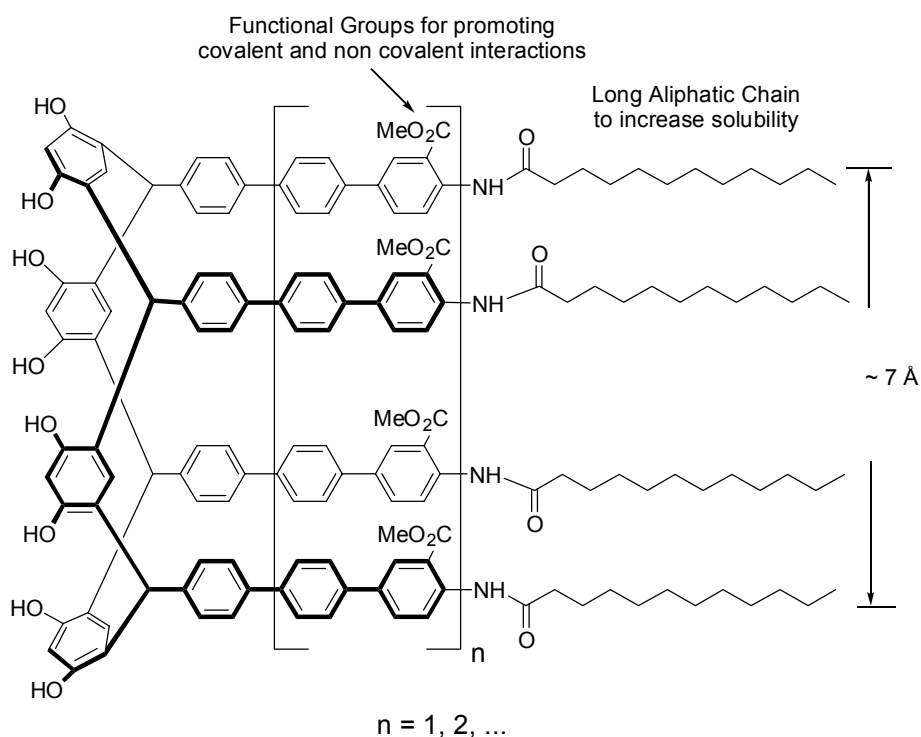

Figure 2.1. Design of a Molecular Scaffold (2.1).

The functionalization of **2.1** with carboxylate side-groups should allow for binding of relatively complex π -interactive materials in aqueous media. The extended π -cavities should promote strong intercalation of such materials between the aryl pillars. **Figure 2.2** shows an energy-minimized model (Sybyl[®] 6.6) of the important anticancer drug doxorubicin bound in the lower cavity of Molecular Scaffold **2.2** having nine benzene rings attached on each conjugated rod (thirty-six rings in total).

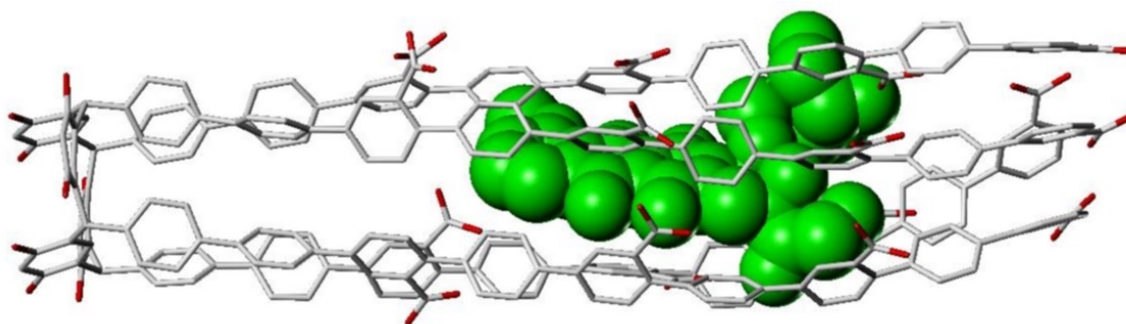

Figure 2.2. Energy Minimized Structure of compound **2.2** ($n = 4$, sticks representation) and Doxorubicin (spacefill representation).

2.2 Specific Goals

2.2.1 Synthesis of functionalized oligo-*p*-phenylenes to the limit of their solubility.

2.2.2 Attachment of the oligo-*p*-phenylenes to the lower rim of a resorcinarene.

2.3 Synthesis of the Oligo-*p*-phenylenes Building Block

Scheme 2.2 describes the synthesis of the building block that was used to construct the pillars that would be attached to the macrocyclic resorcinarene. The starting material was 2-amino-5-iodo-benzoic acid **3.3** which was allowed to react with triphosgene in THF to form the anhydride **2.4**. After undergoing methanolysis catalyzed by DMAP and losing carbon dioxide the methyl ester **2.5** was obtained. **2.5** was then

coupled with 4-bromo-boronic acid using the Suzuki protocol to form the biphenylic building block **2.6**.

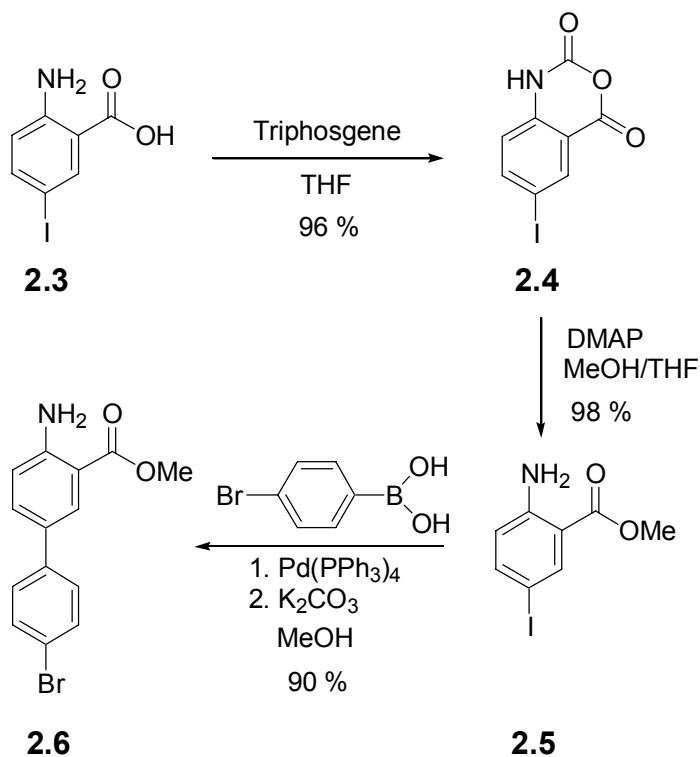

Scheme 2.2 Synthesis of **2.6** which was used as a building block in the synthesis of *p*-oligophenylenes.

2.4 Synthesis of Octomeric *p*-phenylene

Compound **2.6** was divided in two portions (Scheme 2.3). By using *t*-butylnitrite and iodine in benzene in one of the portions the amino group was replaced by iodine to afford compound **2.7**. The other portion of **2.6**, was allowed to react with bis(pinacolato)diboron forming the boronic ester **2.8**. After that, a Suzuki coupling between **2.7** and **2.8** led to the tetramer **2.9**.

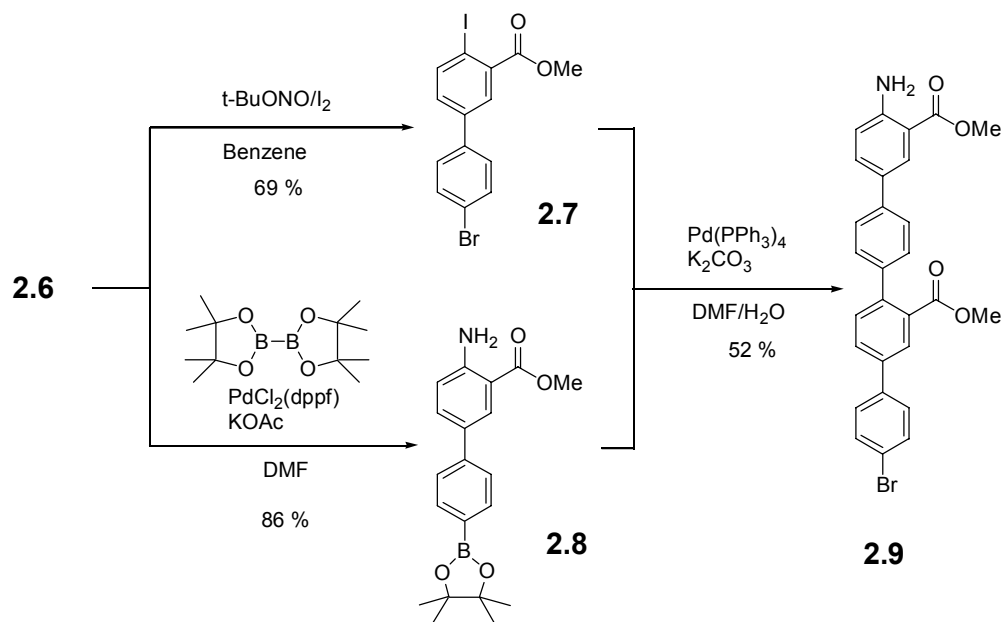

Scheme 2.3 Molecular Doubling. Specific functionalization of **2.6** to make **2.7** and **2.8** that can couple together to obtain tetramer **2.9**

Compound **2.9** was divided in two portions (Scheme 2.4), in one of the portions the amino group was replaced by iodine to afford compound **2.10** using *t*-butylnitrite and iodine in benzene. The other portion of **2.9**, was allowed to react with bis(pinacolato)diboron forming the boronic ester **2.11**.

The coupling of **2.10** with **2.11** to form the octamer **2.12** was unsuccessful. Solubility became a determinant factor for this reaction. In order to synthesize the octamer, long alkyl groups had to be incorporated to increase the solubility.

2.5 Synthesis of Oligo-*p*-phenylenes with a Long Aliphatic Chain Attached

A long alkyl chain was incorporated by derivatizing the amino group of compound **2.6** to form an amide. First, the reaction with undecanoic acid in the presence of 1,3-dicyclohexylcarbodiimide (DCC) was attempted, but the reaction didn't work. Then 4-dimethylaminopyridine (DMAP) was added along with 1-hydroxybenzotriazole (HOBT), but no reaction was observed again.

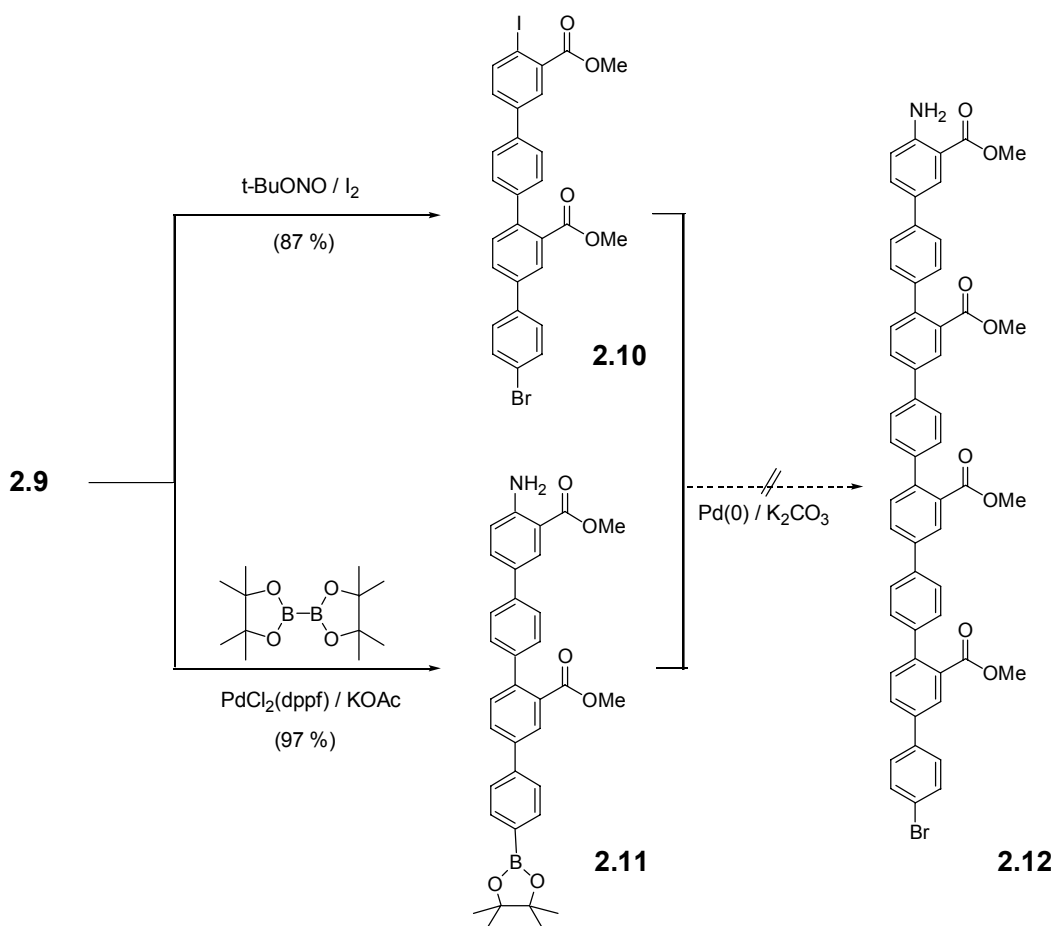

Scheme 2.4 Compound **2.12** couldn't be synthesized from the functionalized tetramers.

The delocalization of the electrons on the nitrogen by resonance in the aromatic amine probably contributed to make this compound less nucleophilic. If the nucleophile is not reactive enough, then the reactivity of the electrophile could be increased. Undecanoic acid was substituted with lauroyl chloride. This time **2.6** reacted with lauroyl chloride in the presence of triethylamine to afford amide **2.13** (Scheme 2.5) in an excellent yield (100%). Acylation of tetramer **2.9** produced amide **2.14** with a similar yield.

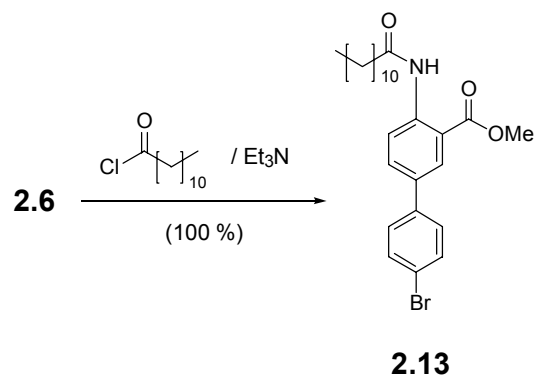

Scheme 2.5 The lauroyl amide of the building block **2.6**.

The boronic ester **2.11** was acylated with lauroyl chloride in the presence of 2,6-ditert-butyl pyridine (triethylamine gave low yields in this case) to give amide **2.15** in a good yield (82 %). Amide **2.15** was then coupled with compound **2.10** to obtain the octamer **2.16** (Scheme 2.6).

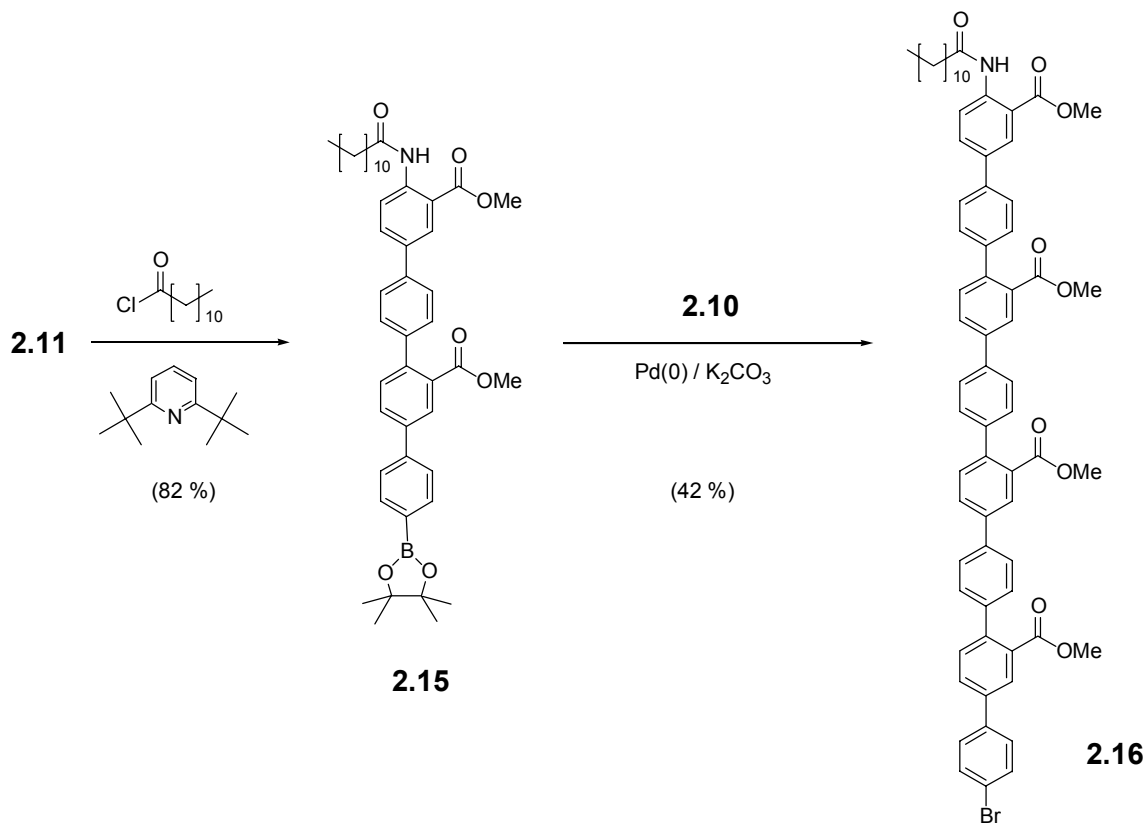

Scheme 2.6 Synthesis of octamer **2.16**.

2.6 Coupling of Oligo-*p*-phenylenes with Resorcinarene.

After several attempts, the direct couplings of the dimer **2.6** and tetramer **2.9** with the resorcinarene **2.17** were unsuccessful (Scheme 2.7). The reason might be the steric hindrance in the lower cavity of **2.17**.

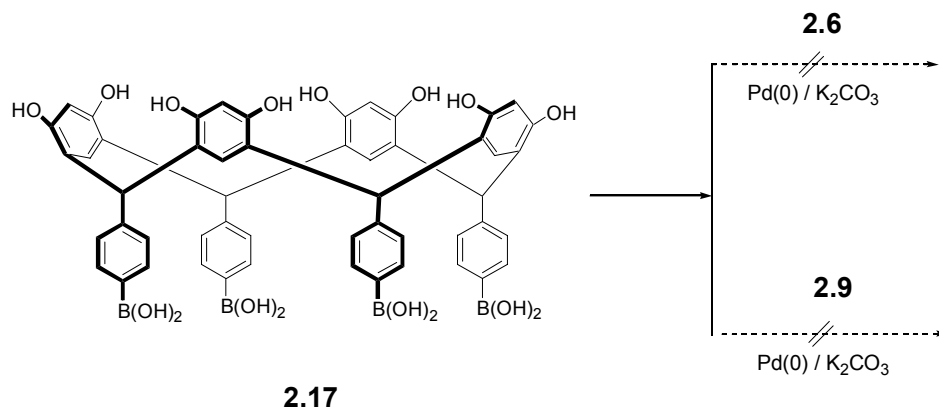

Scheme 2.7 Coupling of resorcinarene **2.17** with oligophenylenes **2.6** and **2.9**.

A new approach involving the insertion on an extra ring with an aldehyde function to the oligo-*p*-phenylenes was carried out. The aldehydes upon condensation with resorcinol could produce the desired resorcinarenes according to Scheme 2.7. One of the drawbacks of this approach was that yield had to be sacrificed due to the formation of two diastereomers (*C_{4v}* and *C_{2h}*). Compounds **2.13** and **2.14** were coupled with 4-formylphenylboronic acid to afford aldehydes **2.18** and **2.19** respectively (Scheme 2.8).

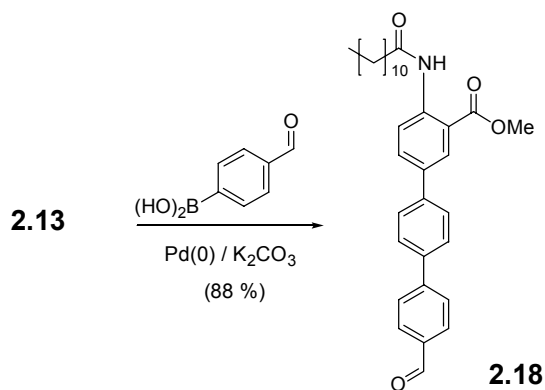

Scheme 2.8 Coupling of **2.13** and **2.14** with 4-formylphenylboronic acid

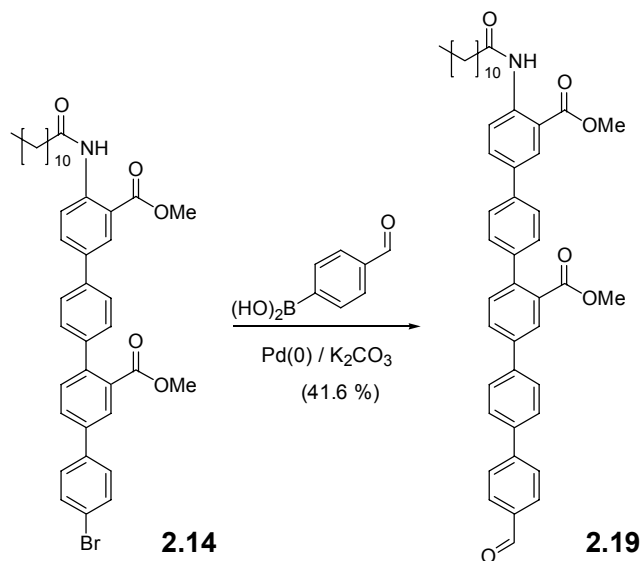

Scheme 2.8 (continued) Coupling of oligophenylenes **2.13** and **2.14** with 4-formylphenylboronic acid.

P. Beck^{2.15} in our research group continued working to synthesize resorcinarenes from aldehydes **2.18** and **2.19** and resorcinol (Scheme 2.9). She obtained a mixture of the C_{4v} (crown) and C_{2h} (chair) isomers.

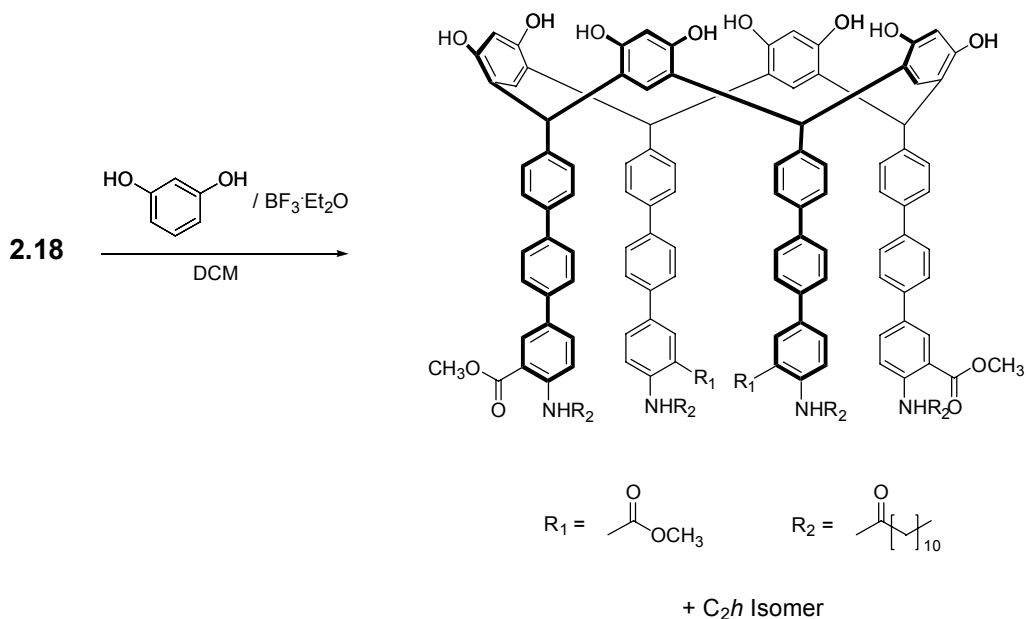

Scheme 2.9 Condensation of compound **2.18** with resorcinol.

2.7 Conclusions and Future Work:

In conclusion, an efficient synthesis of a highly functional octameric oligo(*p*-phenylene) using a molecular doubling approach has been accomplished. Transesterification of the side groups to, for instance, glycolate esters at the tetramer stage or earlier should allow the repetitive scheme to continue without end group functionalization with a solubilizing moiety, thereby affording longer rigid rods if needed. Decarboxylation to remove the side groups would furnish novel telechelic rigid rod phenylenes with unsubstituted repeat units. The use of **2.5** in this scheme also allows for further synthetic streamlining via the application of one-pot arylborylation/cross-coupling methods. Further successful synthetic transformations and the incorporation of new rigid rod oligo(*p*-phenylene)s into unique, well-defined nanoscale oligoaromatic architectures has now also been achieved in our laboratory.

2.8 Experimental section.

All chemicals were purchased from the Aldrich Chemical Company and used without further purification. Unless otherwise noted, all non aqueous reactions were carried out under dry nitrogen atmosphere in flame dried glassware. DCM was distilled over CaH₂ prior to use. Anhydrous DMF, MeOH and THF were purchased in sure-seal bottles. Analytical thin-layer chromatography (TLC) was performed using general purpose 60-Å silica gel on glass (Aldrich). Flash Chromatography columns were prepared with Kieselgel 60-Å silica gel 230-400 mesh (Merck). ¹H NMR spectra was acquired with Bruker AC-250 and Bruker AC-300 spectrometers (¹H NMR Spectra is shown in Appendix A).

- **Compound 2.4:** Triphosgene (4.3 g, 0.0145 mol), dissolved in 50 mL anhydrous THF was added dropwise to 2-amino-5-iodo-benzoic acid (10.0 g, 0.0380 mol) dissolved in 200 mL anhydrous THF at 0 °C. The reaction was warmed to 60 °C overnight, cooled and filtered. Concentration of the mother liquor, followed by filtration afforded 9.9132 g (90.19%) of compound **2.4**. ¹H NMR (DMSO-d₆): δ 6.94 (d, *J* = 8.54 Hz, 1H), 8.00 (dd, *J* = 1.98, 8.55 Hz, 1H), 8.11 (d, *J* = 1.97 Hz, 1H) 11.9 (bs, 1H).

- **Compound 2.5:** Anhydrous methanol (20 mL, 0.494 mol) was added dropwise to a solution of compound **2.4** (9.845 g, 0.0340 mol) and DMAP (0.330 g, 2.70 mmol) in anhydrous DMF (200 mL). The reaction was heated to 60 °C for 3 h and the solvent removed under reduced pressure. Both water (100 mL) and ethyl acetate (100 mL) were added and the aqueous phase extracted with ethyl acetate (3 X 100 mL). The combined organic layers were dried with magnesium sulfate. Evaporation of the solvent left 8.964 g (94.3 %) of a light yellow solid. ¹H NMR (CDCl₃): δ 3.78 (s, 3H), 5.72 (bs, 2H), 6.38 (d, *J* = 8.71 Hz, 1H), 7.39 (dd, *J* = 2.18, 8.69 Hz, 1H), 8.06 (d, *J* = 2.17 Hz, 1H). ¹³C NMR (CDCl₃): δ 51.7, 112.7, 118.7, 139.4, 142.1, 149.7, 156.7, 167.3..

- **Compound 2.6:** Compound **2.5** (8.964 g, 0.0323 mol), 4-bromobenzenboronic acid (7.228 g, 0.0360 mol), potassium carbonate (9.600 g, 0.0694 mol), and tetrakis-(triphenylphosphine) (1.120 g, 0.9692 mmol) were dissolved in anhydrous methanol. The reaction was purged with nitrogen and heated to 60 °C for 3 h. The methanol was removed under reduced pressure followed by the addition of both water and ethyl acetate. The layers were separated and the aqueous phase extracted with ethyl acetate (3 X 100 mL). The combined organic layers were dried with magnesium sulfate and the solvent removed under reduced pressure. Chromatography (DCM)

yielded 6.8 g (68.7 %) of a light yellow solid. $^1\text{H NMR}$ (CDCl_3): δ 3.91 (s, 3H), 5.88 (bs, 2H), 6.78 (d, $J = 8.56$ Hz, 1H), 7.40 (d, $J = 8.63$ Hz, 2H), 7.51 (d, $J = 8.59$ Hz, 2H), 7.51 (dd, $J = 2.31, 8.62$ Hz, 1H), 8.09 (d, $J = 2.28$ Hz, 1H).

- **Compound 2.7:** To a solution of Compound **2.6** (10.65 g, 10.6 mmol) and iodine (1.62 g, 6.38 mmol) in anhydrous benzene (100 mL) was added t-butyl nitrite (90 %, 1.55 mL, 11.72 mmol) at 0 °C. The reaction was warmed to room temperature overnight and then heated to 60 °C for 10 minutes. Water was added (100 mL) and the layers separated. The aqueous phase was extracted with ethyl acetate (3 x 100 mL), the combined organic layers were dried with magnesium sulfate, and the solvent removed under reduced pressure. Chromatography (DCM) followed by trituration in hexane afforded 3.05 g (68.8 %) of a brown solid. $^1\text{H NMR}$ (CDCl_3): δ : 3.96 (s, 3H), 7.33 (dd, $J = 2.26, 8.25$ Hz, 1H), 7.44 (d, $J = 8.38$ Hz, 2H), 7.58 (d, $J = 8.41$ Hz, 2H), 7.98 (d, $J = 2.32$ Hz, 1H), 8.05 (d, $J = 8.25$ Hz, 1H).

- **Compound 2.8:** Compound **2.6** (2.00 g, 6.53 mmol), bis(pinacolato)diboron (1.93 g, 7.60 mmol), potassium acetate (2.385 g, 24.3 mmol), and [1,1'-bis(diphenylphosphino)ferrocene] dichloropalladium(II) (0.120 g, 0.216 mmol) were dissolved in anhydrous DMF. The reaction was heated to 60 °C overnight, cooled, and filtered through a pad of celite. The solvent was removed *in vacuo* followed by addition of both water (100 mL) and DCM (100 mL). The aqueous phase was extracted with DCM (3 X 100 mL) and the combined organic layers dried with magnesium sulfate and concentrated. Chromatography (DCM) followed by trituration in hexane yielded 1.987 g (86.0 %) of a white solid. $^1\text{H NMR}$ (CDCl_3): δ : 1.29 (s, 12H), 3.84 (s, 3H), 6.71 (d, $J = 8.55$ Hz, 1H),

7.48 (d, $J = 8.24$ Hz, 2H), 7.54 (dd, $J = 2.27, 8.49$ Hz, 1H), 7.78 (d, $J = 8.24$ Hz, 1H), 8.09 (d, $J = 2.23$ Hz, 1H)

- **Compound 2.9:** Compound **2.8** (4.660 g, 13.2 mmol), Compound **2.7** (5.002 g, 12.0 mmol), potassium carbonate (3.562 g, 25.8 mmol), and tetrakis(triphenylphosphine) (0.415 g, 0.359 mmol) were dissolved in 4:1 DMF/H₂O solution and heated to 80 °C overnight. Both the water and DMF were removed under vacuum, followed by addition of DMF (100 mL) and filtered through a celite pad. The DMF was again removed under vacuum and both water and DCM was added to the reaction mixture. The phases were separated and the aqueous phase extracted with DCM (3 X 100 mL). removal of the solvent. The combined organic layers were dried with magnesium sulfate and concentrated. Chromatography (DCM) followed by trituration in hexane yielded 3.54 g (52.0 %) of a tan solid. ¹H NMR (CDCl₃): δ: 3.64 (s, 3H), 3.85 (s, 3H), 6.72 (d, $J = 8.54$ Hz, 1H), 7.30 – 7.57 (m, 10H), 7.66 (dd, $J = 2.06, 8.03$ Hz, 1H), 7.95 (d, $J = 1.96$ Hz, 1H), 8.13 (d, $J = 2.22$ Hz, 1H).

- **Compound 2.10:** To a solution of Compound **2.9** (1.40 g, 2.71 mmol) and iodine (0.427 g, 1.68 mmol) in anhydrous benzene (50 mL) was added t-butyl nitrite (90 %, 0.4 mL, 3.02 mmol) at 0 °C. The reaction was warmed to room temperature overnight and then heated to 60 °C for 10 minutes. Water was added (100 mL) and the layers separated. The aqueous phase was extracted with ethyl acetate (3 x 100 mL), the combined organic layers were dried with magnesium sulfate, and the solvent removed under reduced pressure. Chromatography (DCM) followed by trituration in hexane afforded 1.48 g (87.0 %) of a brown solid. ¹H NMR (CDCl₃): δ: 3.73 (s, 3H), 3.97 (s, 3H), 7.42 (d, $J = 8.29$ Hz, 1H), 7.44 (d, $J = 8.21$ Hz, 2H), 7.47 (d, $J = 8.01$ Hz, 1H), 7.52

(d, $J = 8.52$ Hz, 3H), 7.60 (d, $J = 8.52$ Hz, 2H), 7.64 (d, $J = 8.28$ Hz, 2H), 7.73 (dd, $J = 2.02, 7.97$ Hz, 1H), 8.06 (d, $J = 8.02$ Hz, 1H), 8.08 (dd, $J = 2.32, 8.68$ Hz, 1H)

• **Compound 2.11:** Compound **2.9** (1.40 g, 2.71 mmol), bis(pinacolato)diboron (0.7574 g, 2.98 mmol), potassium acetate (0.878 g, 8.94 mmol), and [1,1'-bis(diphenylphosphino)ferrocene]dichloropalladium(II) (0.045 g, 0.081 mmol) were dissolved in anhydrous DMF. The reaction was heated to 60 °C overnight, cooled, and filtered through a pad of celite. The solvent was removed *in vacuo* followed by addition of both water (100 mL) and DCM (100 mL). The aqueous phase was extracted with DCM (3 X 100 mL) and the combined organic layers dried with magnesium sulfate and concentrated. Chromatography (DCM) followed by trituration in hexane yielded 1.482 g (97.0 %) of a white solid. ^1H NMR (CDCl_3): δ : 1.26 (s, 12H), 3.71 (s, 3H), 3.92 (s, 3H), 6.79 (d, $J = 8.52$ Hz, 1H), 7.40 (d, $J = 8.28$ Hz, 2H), 7.49 (d, $J = 7.98$ Hz, 1H), 7.61 (d, $J = 8.25$ Hz, 2H), 7.62 (dd, $J = 2.28, 8.48$ Hz, 1H), 7.78 (dd, $J = 1.99, 8.00$ Hz, 1H), 7.92 (d, $J = 8.51$ Hz, 2H), 8.09 (d, $J = 1.93$ Hz, 1H), 8.20 (d, $J = 2.24$ Hz, 1H).

• **Compound 2.13:** To a solution of Compound **2.6** (2.00 g, 6.53 mmol) and triethylamine (1.00 mL, 7.17 mmol) in anhydrous DCM was added lauroyl chloride (1.60 mL, 6.88 mmol) at 0 °C. The reaction was warmed to room temperature and refluxed for 2 h. Water (50 mL) was added and the phases separated. The aqueous phase was extracted with DCM (3 x 50 mL) and the combined organic layers were dried with magnesium sulfate and concentrated to afford 3.20 g (100 %) of a light yellow solid. ^1H NMR (CDCl_3): δ : 0.80 (t, $J = 6.35$ Hz, 3H), 1.18 (m, 16H), 1.70 (p, $J = 7.36$ Hz, 2H), 2.39 (t, $J = 7.33$ Hz, 2H), 3.90 (s, 3H), 7.38 (d, $J = 8.62$ Hz, 2H), 7.50 (d, $J = 8.59$, 2H),

7.67 (dd, $J = 2.35$, 8.81 Hz, 1H), 8.16 (d, $J = 2.30$ Hz, 1H), 8.75 (d, $J = 8.81$ Hz, 1H), 11.01 (bs, 1H).

- **Compound 2.14:** To a solution of Compound **2.11** (0.67 g, 1.30 mmol) and triethylamine (0.24 mL, 1.72 mmol) in anhydrous DCM was added lauroyl chloride (0.30 mL, 1.29 mmol) at 0 °C. The reaction was warmed to room temperature and refluxed for 2 h. Water (50 mL) was added and the phases separated. The aqueous phase was extracted with DCM (3 x 50 mL) and the combined organic layers were dried with magnesium sulfate and concentrated. The resulting solid was triturated in hexanes and filtered to give 0.781 g (100 %) of a light yellow solid. $^1\text{H NMR}$ (CDCl_3): δ : 0.81 (t, $J = 6.81$ Hz, 3H), 1.19 (m, 16H), 1.71 (p, $J = 7.12$ Hz, 2H), 2.40 (t, $J = 7.40$ Hz, 2H), 3.65 (s, 3H), 3.91 (s, 3H), 7.34 – 7.60 (m, 9H), 7.67 (dd, $J = 2.04$, 8.00 Hz, 1H), 7.77 (dd, $J = 2.1$, 8.84 Hz, 1H), 7.97 (d, $J = 1.86$ Hz, 1H), 8.27 (d, $J = 2.17$ Hz, 1H), 8.77 (d, $J = 8.79$ Hz, 1H), 11.02 (bs, 1H).

- **Compound 2.15:** To a solution of Compound **2.11** (0.391 g, 0.692 mmol) and 2,6 ditert-butylpyridine (0.171 mL, 0.762 mmol) in anhydrous DCM was added lauroyl chloride (0.17 mL, 0.731 mmol) at 0 °C. The reaction was allowed to warm to room temperature overnight followed by the addition of water (50 mL). The phases were separated and the aqueous phase extracted with DCM. The combined organic layers were dried with magnesium sulfate and concentrated. Chromatography (hexane, 5 % Ethyl acetate/ hexane, 10 % ethyl acetate/hexane, followed by 20% ethyl acetate/hexane) yielded 0.423 g (81.8 %) of a light yellow solid. $^1\text{H NMR}$ (CDCl_3): δ : 0.81 (t, $J = 6.85$ Hz, 3H), 1.97 (m, 16H), 1.31 (s, 12H), 1.71 (p, $J = 7.33$ Hz, 2H), 2.40 (t, $J = 7.36$ Hz, 2H), 3.66 (s, 3H), 3.91 (s, 3H), 7.35 – 7.45 (m, 3H), 7.57 (d, $J = 7.02$ Hz, 2H), 7.61 (d, J

= 6.97 Hz, 2H), 7.73 (dd, $J = 1.87, 8.06$ Hz, 1H), 7.78 (dd, $J = 2.06, 8.80$ Hz, 1H), 7.85 (d, $J = 8.05$ Hz, 2H), 8.04 (d, $J = 1.87$ Hz, 1H), 8.27 (d, $J = 2.22$ Hz, 1H), 8.77 (d, $J = 8.80$ Hz, 1H), 11.0 (bs, 1H).

• **Compound 2.16:** Compound **2.15** (0.081 g, 0.124 mmol), Compound **2.10** (0.0697 g, 0.111 mmol), potassium carbonate (0.0322 g, 0.232 mmol), and tetrakis-(triphenylphosphine)palladium(0) (0.004 g, 3.46×10^{-3} mmol) were dissolved in DMF and heated to 80 °C overnight. The resulting precipitate was filtered and dried. Chromatography (1% Ethanol/CHCl₃) resulted in 0.0527 g (42.4 %) of a white solid. ¹H NMR (CDCl₃): δ : 0.88 (t, $J = 6.85$ Hz, 3H), 1.26 (m, 16H), 1.78 (p, $J = 7.12$ Hz, 2H), 2.48 (t, $J = 7.32$ Hz, 2H), 3.73 (s, 3H), 3.75 (s, 6H), 3.98 (s, 3H), 7.45–7.88 (m, 23H), 8.06 (d, $J = 1.92$ Hz, 1H), 8.17 (d, $J = 1.74$ Hz, 2H), 8.35 (d, $J = 2.22$ Hz, 1H), 8.86 (d, $J = 8.84$ Hz, 1H), 11.01 (bs, 1H).

• **Compound 2.18:** Compound **2.13** (4.00 g, 8.18 mmol), 4-formylbenzeneboronic acid (1.35 g, 9.00 mmol), potassium carbonate (2.37 g, 17.1 mmol), and tetrakis-(triphenylphosphine) palladium(0) (0.212 g, 0.183 mmol) were dissolved in anhydrous DMF. The reaction was purged with nitrogen and heated to 80 °C for overnight. The reaction mixture was filtered through celite and concentrated. Both water (100 mL) and DCM (100 mL) were added and the phases separated. The aqueous phase was extracted with DCM (3 X 100 mL), dried over magnesium sulfate, and concentrated under reduced pressure. Chromatography (DCM) yielded 3.68 g (87.6 %) of a light yellow solid. ¹H NMR (CDCl₃): δ 0.83 (t, $J = 6.85$ Hz, 3H), 1.19 (bm, 16H), 1.71 (p, $J = 7.53$ Hz, 2H), 2.40 (t, $J = 7.38$ Hz, 2H), 3.91 (s, 3H), 7.65 - 7.79 (m, 7H),

7.94 (d, $J = 8.34$ Hz, 2H), 8.25 (d, $J = 2.27$ Hz, 1H), 8.78 (d, $J = 8.81$ Hz, 1H), 10.02 (s, 1H), 11.03 (bs, 1H).

• **Compound 2.19:** Compound **2.14** (0.64 g, 0.916 mmol), 4-formylbenzeneboronic acid (0.200 g, 1.33 mmol), potassium carbonate (0.275 g, 1.98 mmol), and tetrakis-(triphenyl phosphine)palladium(0) (0.032 g, 0.027 mmol) were dissolved in anhydrous DMF. The reaction was purged with nitrogen and heated to 80°C for overnight. The reaction mixture was filtered through celite and concentrated. Both water (100 mL) and DCM (100 mL) were added and the phases separated. The aqueous phase was extracted with DCM (3 X 100 mL), dried over magnesium sulfate, and concentrated under reduced pressure. Chromatography (DCM) yielded 0.276 g (41.6 %) of a light yellow solid. ^1H NMR (CDCl_3): δ : 0.81 (t, $J = 6.92$ Hz, 3H), 1.19 (m, 16H), 1.71 (p, $J = 7.28$ Hz, 2H), 2.41 (t, $J = 7.33$ Hz, 2H), 3.67 (s, 3H), 3.91 (s, 3H), 7.37 – 7.47 (m, 3H), 7.56 – 7.79 (m, 10H), 7.93 (d, $J = 8.38$ Hz, 2H), 8.08 (d, $J = 1.88$ Hz, 1H), 8.28 (d, $J = 2.17$ Hz, 1H), 8.78 (d, $J = 8.81$ Hz, 1H), 10.01 (s, 1H), 11.03 (bs, 1H).

2.9 References:

- 2.1 (a) Schneider, H.-J.; Schneider, U. "The Host-Guest Chemistry of Resorcinarenes," *J. Inclusion Phenom.* **1994**, *19*, 67. (b) *Container Molecules and Their Guests*; Cram, D. J.; Cram, J. M., The Royal Society of Chemistry: Cambridge, U.K. **1994**. (c) Sherman, J. C. "Carceplexes and Hemicarceplexes: Molecular Encapsulation-from Hours to Forever," *Tetrahedron* **1995**, *51*, 3395. (d) Timmerman, P.; Verboom, W.; Reinhoudt, D. N. "Resorcinarenes," *Tetrahedron* **1996**, *52*, 2663.
- 2.2 Cram, D. J.; Tanner, M. E.; Thomas, R. "The Taming of Cyclobutadiene," *Angew. Chem.*, **1991**, *103*, 1048; *Angew Chem, Int. Ed. Engl.* **1991**, *30*, 1024. (b) Warmuth, R. "*o*-Benzyne: Strained Alkyne or Cumulene?-NMR Characterization in a Molecular Container," *Angew Chem, Int. Ed. Engl.* **1997**, 1347
- 2.3 (a) Timmerman, P.; Veerboom, W.; van Veggel, F. C. J. M.; van Hoorn, W. P.; Reinhoudt, D. N. "An Organic Cavity of Nanosize Dimensions," *Angew Chem*,

- Int. Ed. Engl.* **1994**, *33*, 1292. (b) Chopra, N.; Sherman, J. C. "A Bis(carceplex) from a Cyclic Tetramer of Cavitands," *Angew. Chem., Int. Ed. Engl.*, **1997**, *36*, 1727.
- 2.4 (a) Botta, B.; Iacomacci, P.; Di Giovanni, C.; Della Monache, G.; Gacs-Baitz, B.; Botta, M.; Tafi, A.; Corelli, F.; Misiti, D. "The Tetramerization of 2,4-Dimethoxycinnamates. A Novel Route to Calixarenes," *J. Org. Chem.* **1992**, *57*, 3259. (b) Botta, B.; Di Giovanni, C.; Delle Monache, G.; De Rosa, M. C.; Gacs-Baitz, B.; Botta, M.; Corelli, F.; Tafi, A.; Santini, A.; Benedetti, B.; Pedone, C.; Misiti, D. "A Novel Route to Calix[4]arenes. 2. Solution- and Solid State Structural Analysis and Molecular Modeling Studies," *J. Org. Chem.* **1994**, *59*, 1532. (c) Gibb, B. C.; Chapman, R. G.; Sherman, J. C. "Synthesis of Hydroxy-Footed Cavitands," *J. Org. Chem.* **1996**, *61*, 1505. (d) Botta, B.; Di Giovanni, C.; Delle Monache, G.; Salvatore, P.; Gasparrini, F.; Villiani, C.; Botta, M.; Corelli, F.; Tafi, A.; Gacs-Baitz, E.; Santini, A.; Benedetti, E.; Carvalho, C. F.; Misiti, D. "Synthesis of C-alkylcalix[4]arenes. 4. Design, Synthesis, and Computational Studies of Novel Chiral Amido[4]resorcinarenes," *J. Org. Chem.* **1997**, *62*, 932. (e) Botta, B.; Delle Monache, G.; De Rosa, M. C.; Seri, C.; Benedetti, B.; Iacovino, R.; Botta, M.; Corelli, F.; Masignani, V.; Tafi, A.; Gacs-Baitz, E.; Santini, A.; Misiti, D. "Synthesis of C-Alkylcalix[4]arenes. 5. Design, Synthesis, Computational Studies, and Homodimerization of Polymethylene-Bridged Resorc[4]arenes," *J. Org. Chem.* **1997**, *62*, 1788. (g) Curtis, A. D. M. "Novel Calix[4]resorcinarene Glycosides," *Tetrahedron Lett.* **1997**, *38*, 4295.
- 2.5 (a) *Electronic Properties of Conjugated Polymers*; Kuzmany, H.; Mehring, M.; Roth, S., Eds.; Springer: Berlin, 1987. (b) Heeger, A. J.; Kivelson, S.; Schrieffer, J. R.; Su, W.-P. "Solitons in Conducting Polymers," *Rev. Mod. Phys.* **1988**, *60*, 781.
- 2.6 (a) *Introduction to Nonlinear Optical Effects in Molecules and Polymers*; Prasad, P. N. Williams, D. J.; Wiley: New York, 1991. (b) Nie, "Optical Nonlinearity: Phenomena, Applications, and Materials," *W. Adv. Mater.* **1993**, *5*, 520. (c) *Principles and Application of Nonlinear Optical Devices*; Munn, R. W.; Ironside, C. N.; Chapman & Hall: London, 1993.
- 2.7 (a) Schuhmann, W.; Huber, J.; Mirlach, A.; Daub, J. "Covalent Binding of Glucose Oxidase to Functionalized Polyazulenes. The First Application of Polyazulenes in Amperometric Biosensors," *Adv. Mater.* **1993**, *5*, 124. (b) Matsue, T.; Nishizawa, M.; Sawaguchi, T.; Uchida, I. *J. Chem. Soc., Chem. Commun.* **1993**, 1029. (c) Marsella, M. J.; Swager, T. M. "Designing Conducting Polymer-Based Sensors: Selective Ionochromic Response in Crown Ether Containing Polythiophenes," *J. Am. Chem. Soc.* **1993**, *115*, 12214. (d) McCullough, R. D.; Williams, S. P. J. "Toward Tuning Electrical and Optical Properties in Conjugated Polymers Using Side Chains: Highly Conductive Head-to Tail Heteroatom- Functionalized Polythiophenes," *J. Am. Chem. Soc.*

- 1993**, *115*, 11608. (e) Swager, T. M.; Marsella, M. J. "Molecular Recognition and Chemoresistive Materials," *Adv. Mater.* **1994**, *6*, 595. (f) Marsella, M. J.; Carroll, P. J.; Swager, T. M. *J. Am. Chem. Soc.* "Conducting Pseudopolyrotaxanes: A Chemoresistive Response via Molecular Recognition," **1994**, *116*, 9347.
- 2.8 (a) Braun, D.; Heeger, A. "Visible Light Emission from Semiconducting Polymer Diodes," *J. Appl. Phys. Lett.* **1991**, *58*, 1982. (b) Greenham, N. C.; Moratti, S. C. Bradley, D. D. C.; Friend, R. H.; Holmes, A. B. "Efficient Light-Emitting Diodes Based on Polymers with High Electron Affinities," *Nature* **1993**, *365*, 628. (c) Gruener, J.; Wittmann, H. F.; Hamer, P. J.; Friend, R. H.; Huber, J.; Scherf, U.; Muellen, K.; Moratti, S. C.; Holmes, A. B. "Electroluminescence and Photoluminescence Investigations of the Yellow Emission of Devices Based on Ladder-Type Oligo(*p*-Phenylene)s," *Synth. Met.* **1994**, *67*, 181.
- 2.9 (a) Ried, W.; Freitag, D. "Oligophenyls, Oligophenylenes, and Polyphenyls, a Class of Thermally Very Stable Compounds," *Angew. Chem.*, 1968, *80*, 932; *Angew. Chem., mt. Ed. Engl.*, **1968**, *7*, 835. (b) Bohnen, A.; Heitz, W.; Müllen, K.; Rädier, H.-J.; Schenk, R. "Redoxchemical Investigations of Soluble Oligo(*p*-phenylene)s," *Makromol. Chem.* **1991**, *192*, 1679. (c) Grem, G.; Leditzky, G.; Ullrich, B.; Leising, G. "Realization of a Blue-Light Emitting Device Poly(*p*-Phenylene)," *Adv. Mater.* **1992**, *4*, 36.
- 2.10 Reviews: (a) Noren, G. K.; Stille, J. K. "Polyphenylenes," *Macromol. Rev.* **1971**, *5*, 385. (b) Kovacic, P.; Jones, M. B. *Chem. Rev.* **1987**, *87*, 357. (c) Tourillon, G. in *Handbook of Conducting Polymers*; Skotheim, T. A., Ed.; Dekker: New York, 1986. (d) Baughman, R. H.; Bredas, J. L.; Chance, R. R.; Elsenbaumer, R. L.; Shacklette, L. W. "Structural Basis for Semiconducting and Metallic Polymer/Dopant Systems," *Chem. Rev.* **1982**, *82*, 209.
- 2.11 Review: Tour, J. M. "Soluble Oligo- and Polyphenylene," *Adv. Mater.* **1994**, *6*, 190. For some recent examples see: (a) Rehahn, M.; Schlüter, A. D.; Wegner, G.; Feast, W. J. "Soluble Poly(*p*-Phenylenes). 1. Extension of the Yamamoto Synthesis to Dibromobenzenes Substituted with Flexible Side Chain," *Polymer* **1989**, *30*, 1054. (b) Kim, Y. H.; Webster, O. W. "Water Soluble Hyperbranched Polyphenylene: A Unimolecular Micelle," *J. Am. Chem. Soc.* 1990, *112*, 4592. (d) Wallow, T. I.; Novak, B. N. "In Aqua Synthesis of Water Soluble Poly(*p*-Phenylene) Derivatives," *J. Am. Chem. Soc.* **1991**, *113*, 7411. (e) Francois, B.; Zhong, X. F. "Synthesis, Characterization and Doping of Soluble Diblock and Triblock Copolymers Including Poly-*p*-phenylene Sequences," *Synth. Met.* **1991**, *41*, 955. (f) Rehahn, M.; Schlüter, A. D.; Wegner, G. "Soluble Poly(*p*-Phenylenes). 3. Variation of the Length and the Density of the Solubilizing SideChains." *Makromol. Chem.* **1990**, *191*, 1991. (g) Kallitsis, J.K.; Rehahn, M.; Wegner, G. "Synthesis of Telechelic Poly(*p*-Phenylene) Derivatives." *Makromol. Chem.* **1992**, *193*, 1021. (h) Rau, I. U.; Rehahn, M. "Poly(*p*-

Phenylene) with Polar Side Groups. 1. Palladium-Catalyzed Synthesis, Characterization, and Modification of Poly(*p*-Phenylenes) Bearing Butoxymethyl Side Chains.” *Makromol. Chem.* **1993**, 194, 2225. (i) Rau, I. U.; Rehahn, M. “Rigid-Rod Polyelectrolytes: Carboxylated Poly(*p*-Phenylenes) via a Novel Precursor Route,” *Polymer* **1993**, 34, 2889. (j) Wang, G. Y.; Quirk, R. P. “Approaches to Soluble and Processible High Molecular Weight Substituted Poly(*p*-Phenylene)s 1. Synthesis and Characterization of Poly(Benzoyl-1,4-Phenylene) *Polym. Prepr.* **1994**, 35, 712. (k) Huber, J.; Scherf, U. “A Soluble poly(*p*-phenylene) Composed of Cyclophane Units: poly[2,5-(oxydecanoxy)-1,4-phenylene],” *Macromol. Rapid Commun.* **1994**, 15, 897. (l) Balanda, P. B.; Child, A. D.; Reynolds, J. R. “Towards the Synthesis of Highly Functionalized Poly(*p*-phenylene)s. *Polym. Prepr.* **1994**, 35, 257. (m) Grem, G.; Paar, C.; Stampfl, J.; Leising, G.; Huber, J.; Scherf, U. “Soluble Segmented Stepladder Poly(*p*-Phenylenes) for Blue-Light-Emitting Diodes,” *Chem. Mater.* **1995**, 7, 2. (n) Qian, X.; Pena, M. “Palladium Catalysis of Ditriflates for the Preparation of Soluble Poly(phenylene) Derivatives,” *Macromolecules* **1995**, 28, 4415. (o) Qian, X.; Pena, M. R. “Application of Palladium-Catalysis of Triflates for the Preparation of Soluble Oligomeric Poly(phenylene)-Type Material,” *Polym. Prepr.* **1994**, 35, 860. (p) Kim, S.; Child, A. D.; Williams, K. R.; Reynolds, J. R. “Water Soluble Sulfonatopropoxy Substituted Poly(*p*-Phenylenes) Synthesized via Palladium Catalysis,” Kim, S.; Child, A. D.; Williams, K. R.; Reynolds, John R. *Polym. Mater. Sci. Eng.* **1995**, 73, 544. (q) Galda, P.; Rehahn, M. “A Versatile Palladium-Catalyzed Synthesis of *n*-Alkyl-Substituted Oligo-*p*-Phenyls,” *Synthesis* 1996, 5, 614. (r) Fu, T. “Synthesis and Characterization of Soluble Alkoxy-Substituted Poly(*p*-Phenylenes),” *Polym. Prepr.* 1997, 38, 410. (s) Stephens, J. A.; Friend, R. H.; Remmers, M.; Neher, D. “Electronic Properties of Soluble Poly(*p*-phenylene) Derivatives.” *Synth. Met.* **84**, **1997**, 645.

- 2.12 Review: Tour, J. M. “Conjugated Molecules of Exact Length and Constitution. Organic Synthesis for the Construction of Nanoarchitectures,” *Chem. Rev.* **1996**, 96, 537.
- 2.13 Liess, P.; Hensel, V.; Schlüter, A.-D. “Oligophenylene Rods: A Repetitive Approach,” *Liebigs Ann.* **1996**, 1037.
- 2.14 Lewis, P. T.; Strongin, R. M. “Resorcinarenes with deepened polyaromatic lower cavities: Synthesis and structure”, *J. Org. Chem.*, **1997**, 63, 6065.
- 2.15 Beck, P. A. M.S. Dissertation, Louisiana State University, Baton Rouge, LA, 2001.

CHAPTER 3

CONVENIENT SYNTHESIS AND SINGLE-CRYSTAL X-RAY STRUCTURES OF TWO TETRAFLUORO[2,2]PARACYCLOPHANE ISOMERS*

3.1 Introduction.

The functionalization of the methylene bridge carbons of the prototypical hydrocarbon [2,2]*p*-cyclophane (**3.1**) (Figure 3.1) has been of interest for many years.^{3.1} For example, bridge-functionalized **3.1** has recently been used as a poly(*p*-phenylenevinylene) (PPV) precursor.^{3.2} In addition, fluorinated [2,2]*p*-cyclophanes have been attracting increased attention. Poly(*p*-xylylene) polymers formed via the vapor deposition polymerization of cyclophane precursors that are either fully^{3.3} or partially^{3.4} fluorinated at their methylene carbons are materials of current technological interest. Compound **3.2** (Figure 3.1), for example, is a precursor to a polymer (Parylene AF4)^{3.5} which has exhibited promise as an interlayer dielectric material in high-speed integrated circuits due to its low dielectric constant.^{3.6} An obstacle to the commercialization of the fluorinated parylenes is the multistep syntheses required to obtain the fluorinated cyclophane precursors. Recently, an exciting new methodology allowing for the large scale synthesis of **3.2** was reported.^{3.7}

The parylene derived from partially fluorinated **3.3a** (Figure 3.1) is also of interest for technological applications, for example as a coating with enhanced oxidative and thermal stability.^{3.8}

*Reprinted in part with permission from *Tetrahedron Letters*, 2001, Volume 42, No. 21, pages 3555-3557; Alfonso Dávila, Jorge O. Escobedo, Mark W. Read, Frank R. Fronczek and Robert M. Strongin; Improved Synthesis and Single-Crystal X-ray Structure Determination of the Tetrafluoro[2,2]-*p*-cyclophane Isomers. Copyright 2001 Elsevier Science.

Previously, Itoh and coworkers synthesized **3.3a** via a five step sequence from **3.1**.^{3,4} The more recent patented procedure for the preparation of **3.3a** involved a three step bromination-oxidation-fluorination sequence starting with the bromination of **3.1**, followed by separation of the isomers, oxidation with AgOAc or NaOAc and fluorination with SF₄ or Et₂NSF₃.^{3,8} I have developed a mild, convenient two step synthesis of a separable mixture of **3.3a** and **3.3b** (Figure 3.1).

3.2 Discussion.

Known compounds **3.4a** and **3.4b** were prepared via the bromination of [2,2]-*p*-cyclophane (**3.1**) according to Cram's procedure in a 2:3 ratio, respectively.^{3.1a} We reasoned that a mild, direct functional group interconversion of **3.4a** and **3.4b** to the difluorides would be more efficient and less costly than the prior syntheses,^{3,4, 3.8} thereby affording a more attractive alternative for industrial preparation.

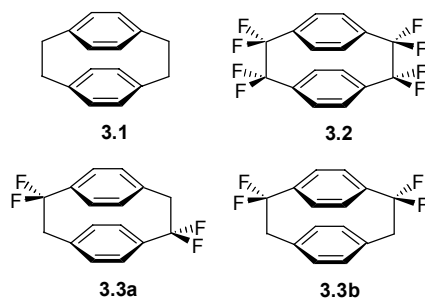
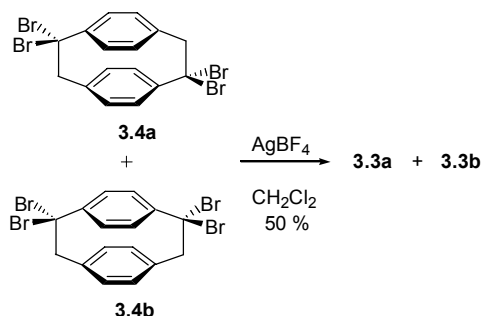

Figure 3.1 Structures of [2,2]-*p*-cyclophane (**3.1**) and its fluorinated derivatives

Bloodworth and Mitchell previously developed a halogen-exchange reaction of geminal dichlorides and diiodides to the corresponding difluorides employing AgBF₄.^{3,9} Based on their procedure we are able to transform the mixture of **3.4a** and **3.4b** (4.72 g, 9 mmol) to the corresponding tetrafluorides **3.3a** and **3.3b** in 50 % isolated yield in a 2:3 ratio via stirring with AgBF₄ (4 equiv) in DCM at rt for 20 h^{3,10} (Scheme 3.1).

Interestingly, the 50 % yield for the difluorination of **3.4a** and **3.4b** is higher than those reported for unstrained dihalides.^{3,9} Separation of **3.3a** and **3.3b** by flash chromatography followed by recrystallization from a 1:1 benzene:hexane solution affords X-ray quality crystals.



Scheme 3.1. Conversion of known tetrabromides **3.4a** and **3.4b** to the fluorinated targets **3.3a** and **3.3b** in a 2:3 ratio.

Compounds **3.3a** and **3.3b**, along with **3.1** and **3.2**, are a homologous series of structurally-related cyclophanes. The crystal structures of **3.1** and **3.2** were previously studied together and were shown to exhibit remarkably similar features. The X-ray crystal structures of **3.3a** and **3.3b** (Figure 3.2) complement the prior X-ray studies of **3.1**^{3,11} and **3.2**.^{3,11c} 1,1,9,9-Tetrafluoro-[2,2]-*p*-cyclophane **3.3a** crystallizes in the monoclinic system with $a=13.8709(5)$, $b=7.8354(5)$, $c=11.6450(9)$ Å, $\beta=99.898(4)^\circ$, space group $C2/c$, and $Z=4$ molecules per cell. 1,1,10,10-Tetrafluoro-[2,2]-*p*-cyclophane **3.3b** crystallizes in the monoclinic system with $a=27.656(2)$, $b=8.1496(9)$, $c=11.364(1)$ Å, $\beta=102.841(8)^\circ$, space group $C2/c$, and $Z=8$ molecules per cell. Both refinements were based on data collected on an Enraf-Nonius CAD4 diffractometer to $\theta=75^\circ$ with Cu $K\alpha$ radiation, yielding $R=0.053$ for all 1281 data for **3.3a** and $R=0.063$ for all 2576 data for **3.3b**. The molecule of **3.3a** lies on a crystallographic inversion center, while that of **3.3b** lies in a general position. The carbon skeletons of **3.3a** and **3.3b** are very similar.

The C-C bridge distance in **3.3a** is 1.545(3) Å, while those in **3.3b** are 1.537(3) and 1.538(4) Å. In **3.3a**, C2 and C5 lie 0.130(2) and 0.162(2) Å, respectively, out of the plane of the other four atoms of the phenyl ring. For **3.3b**, analogous distances are 0.135(2) Å for C2, 0.143(2) Å for C5, 0.158(2) Å for C10, and 0.161(2) Å for C13. The perpendicular distances between these four-atom planes are 3.088(2) Å in **3.3a** and 3.086(2) Å in **3.3b**. C-F distances range 1.359(2) - 1.363(2) Å in **3.3a** and 1.353(3) - 1.370(3) Å in **3.3b**. The F-C-F angle is 104.3(2)° in **3.3a**, and those in **3.3b** are 104.4(1) and 103.6(2)°.

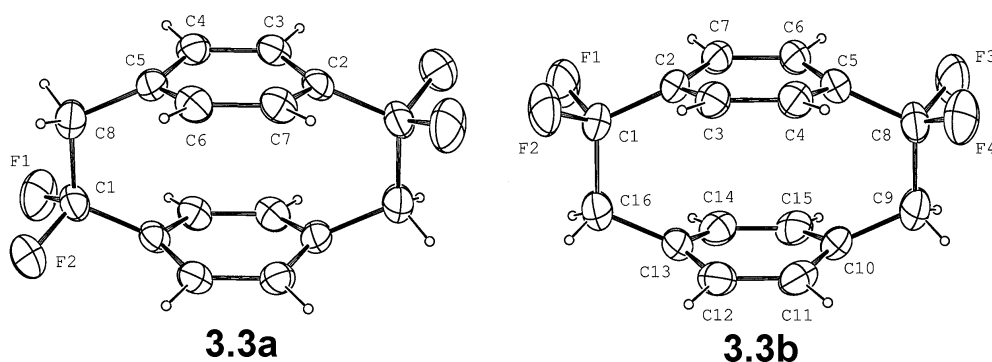

Figure 3.2. X-ray Structures of **3.3a** and **3.3b**

In conclusion, room temperature treatment with AgBF_4 is a mild and convenient technique for introducing fluorines at cyclophane methylene bridge carbons. Parylene precursor cyclophanes **3.3a** and **3.3b** can be directly prepared at room temperature via the corresponding tetrabromide precursors in just two steps from commercially available **3.1**.

3.3 Experimental Section

- **General.** All chemicals were utilized without further purification. Unless otherwise stated, all non-aqueous reactions were carried out in an oxygen free, dry nitrogen atmosphere and in oven-dried glassware. Analytical thin-layer chromatography (TLC) was performed using general purpose 250- μm silica gel on glass (Scientific

Adsorbents Inc.). Flash chromatography columns were prepared with silica gel (Scientific Adsorbents Inc., 32-63 μm particle size, 60 \AA pore size). ^1H , ^{13}C and ^{19}F NMR spectra were obtained with a Bruker AC-250 spectrometer, a Bruker AC-400 spectrometer, or a Bruker AC-500. Mass spectra were acquired using a Bruker Proflex III MALDI Mass Spectrometer.

• **1,1,9,9-Tetrafluoro[2,2]-*p*-cyclophane (3.3a) and 1,1,10,10-tetrafluoro[2,2]-*p*-cyclophane (3.3b).** The mixture of **3.4a:3.4b** (2:3 4.72 g, 9 mmol) is stirred in anhydrous DCM (200 mL) under Ar. AgBF_4 (7.4 g, 38 mmol) is added in small portions through a solid addition funnel. The mixture is stirred 20 h at rt and concentrated *in vacuo*. The black residue was extracted with hot benzene affording a yellowish solid (2.3 g). The residue is sublimed (70 $^\circ\text{C}$, 0.01 mm Hg) affording a white solid (1.25 g, 50%). Column chromatography on silica gel (50 g, 200 mesh) eluting with 1:4 benzene:hexane produced X-ray quality crystals of **3.3b**. Recrystallization of the 1:1 mixture of **3.3a:3.3b** with 1:1 benzene:hexane followed by column chromatography on silica gel (20 g, 200 mesh) eluting with 1:4 benzene:hexane affords X-ray quality crystals of **3.3a**. Data for **3.3a**: mp: 191-193 $^\circ\text{C}$; ^1H -NMR (250 MHz; CDCl_3) δ : 3.61 (t, $J=14.8$ Hz, 4H), 6.96 (dd, 6.80, 8H) ppm. ^{13}C -NMR (125 MHz; CDCl_3) δ : 51.21 (t, $J=33.1$ Hz), 125.86 (t, $J=254.2$ Hz), 129.56 (t, $J=5.8$ Hz), 133.77 (s), 135.03 (t, $J=26.9$ Hz), 138.92 (t, $J=5.1$ Hz) ppm. ^{19}F -NMR (235 MHz; CDCl_3) δ : -91.74 (t, $J=14.8$ Hz, 4F) ppm. HRMS calcd 280.0875, found 280.0874 Data for **3.3b**: mp: 160-161 $^\circ\text{C}$; ^1H -NMR (250 MHz; CDCl_3) δ : 3.59 (t, $J=15$ Hz, 4H), 6.63 (s, 4H), 6.96 (s, 4H) ppm. ^{13}C -NMR (125 MHz; CDCl_3) δ : 50.95 (t, $J=34.0$ Hz), 125.99 (t, $J=254.3$ Hz), 129.65 (t, $J=6.3$ Hz),

133.68 (s), 136.81 (t, $J = 26.9$ Hz), 137.40 (t, $J = 5.3$ Hz) ppm. ^{19}F -NMR (235 MHz; CDCl_3) δ : -92.29 (t, $J = 15$ Hz, 4F) ppm. HRMS calcd 280.0875, found 280.0865.

3.4 References

- 3.1 For example: (a) Dewhirst, K. C.; Cram, D. J.; *J. Am. Chem. Soc.* **1958**, *80*, 3115. (b) Cram, D. J.; Helgeson, R. C. *J. Am. Chem. Soc.* **1966**, *88*, 3516. (c) Chan, C. W.; Wong, H. N. *J. Am. Chem. Soc.* **1985**, *107*, 4790. (d) Stöbbe, M.; Reiser, O.; Näder, R.; de Meijer, A. *Chem. Ber.* **1987**, *120*, 1667. (e) Chan, C. W.; Wong, H. N. *J. Am. Chem. Soc.* **1988**, *110*, 462.
- 3.2 Miao, Y.-J.; Bazan, G. C. *J. Am. Chem. Soc.* **1994**, *116*, 9379.
- 3.3 (a) Chow, S. W.; Pilato, L. A.; Wheelwright, W. L. *J. Org. Chem.* **1970**, *35*, 20. (b) Chow, S. W.; Loeb, W. E.; White, C. E. *J. Appl. Polym. Sci.* **1969**, *13*, 2325.
- 3.4 Itoh, T.; Okuoka, S.; Kubo, M.; Iwatsuki, S. *J. Polym. Sci. A* **1995**, *33*, 359.
- 3.5 Hertler, W. R. *J. Org. Chem.* **1963**, *28*, 2877.
- 3.6 (a) Dabral, S.; Zhang, X.; Wu, X. M.; Yang, G.-R. You, L.; Lang, C. I.; Hwang, K.; Cuan, G.; Chiang, C.; Bakhru, H.; Olson, R.; Moore, J. A.; Lu, T.-M.; McDonald, J. F. *J. Vac. Sci. Technol. B* **1993**, *11*, 1852. (b) Wu, P. K.; Yang, G.-R.; McDonald, J. F.; Lu, T.-M. *J. Electron. Mater.* **1995**, *24*, 53.
- 3.7 (a) Dolbier, W. R., Jr.; Rong, X. X.; Xu, Y. *J. Org. Chem.* **1997**, *62*, 7500. (b) Dolbier, W. R., Jr.; Duan, J.-X.; Roche, A. J. U.S. Patent 5,841,005, **1998**. (c) Dolbier, W. R., Jr.; Duan, J.-X.; Roche, A. J. *Org. Lett.* **2000**, *2*, 1867.
- 3.8 Hiroshi, M. JP 95-208962.
- 3.9 Bloodworth, A. J.; Bowyer, K. J.; Mitchell, J. C. *Tetrahedron Lett.* **1987**, *28*, 5347.
- 3.10 The yield and purification conditions have not yet been fully optimized.
- 3.11 (a) Brown, C. J. *J. Chem. Soc.* **1953**, 3265. (b) Lonsdale, K.; Milledge, J. J.; Rao, K. V. K. *Proc. Roy. Soc.* **1960**, *A255*, 82. (c) Hope, H.; Bernstein, J.; Trueblood, K. N. *Acta Cryst.* **1972**, *B28*, 1733.

CHAPTER 4

AN UNUSUAL SEVEN-BOND H-H SPIN COUPLING*

4.1 Introduction.

This chapter describes my contribution to a former study done by Dr. Norman Bhacca (deceased), Dr. Gary P. Juneau, Dr. David C. Lankin, Dr. Biswapati Mukherjee and Dr. Tapan Seal. They found a rare H-H coupling for tiliacorinine (**4.1**) of 0.4 Hz. DQF-COSY and NOESY NMR studies done by these authors demonstrated that the two sp^2 protons involved in that coupling were seven bonds apart and therefore those protons had to be extremely close. The molecular modeling performed by me of several low-energy conformers of tiliacorinine revealed that the two protons in question could reside 1.84 angstroms from each other.

In NMR spectroscopy, spin-spin interactions between the same or different nuclear species can reveal a variety of structural information. Spatial relationships between protons in a molecule can be typically deduced from measurement of nuclear Overhauser effects. In certain specific instances, through-space proton-proton spin-spin coupling has been used for this purpose.^{4.1} They reported the observation of an unusual seven-bond spin coupling (0.4 Hz) between the resonances of two aromatic protons located on two different benzene rings, that are formally separated by two sp^3 carbon atoms. Bhacca^{4.2} et. al. initially discovered such a long range coupling in 1976,^{4.3} while examining the proton NMR spectra (100 MHz) of several alkaloids.

*Reprinted in part with permission from *Organic Letters*, 2000, Volume 2, No. 24, pages 3813-3815; Norman S. Bhacca, Gary P. Juneau, David C. Lankin, Biswapati Mukherjee, Tapan Seal, Jorge O. Escobedo and Robert M. Strongin; An Unusual Seven-Bond H-H Spin Coupling. Copyright 2000 American Chemical Society.

These alkaloids were extracted from the same plant source: *Tiliacora racemosa* Colebr. (Menispermaceae), a woody climber that grows in the subtropical regions of India where the plant is regarded as an antidote for snake bite. Additionally, it should be pointed out that all alkaloids under study possess the same gross structure, namely, a dibenzo-*p*-dioxin containing bisbenzylisoquinoline with a diphenyl unit (Figure 4.1).^{4,4}

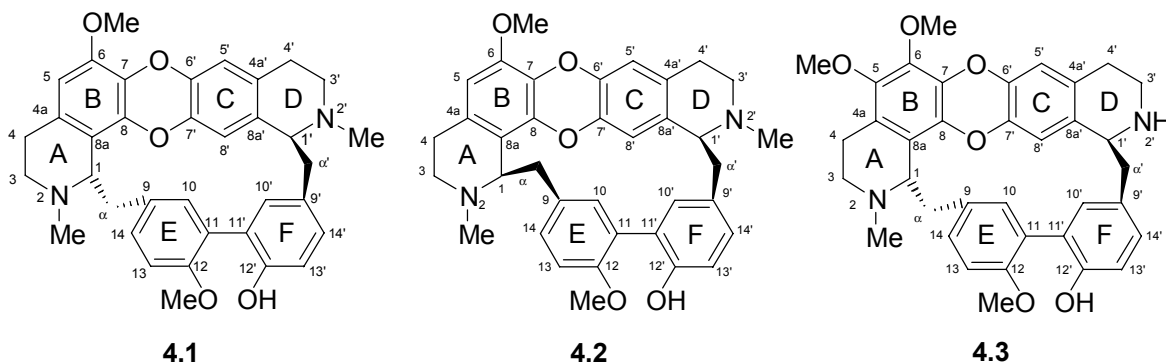

Figure 4.1 Structures and numbering system of the alkaloids tiliacorinine (**4.1**), tiliacorine (**4.2**) and tiliamosine (**4.3**)

4.2 Background

In the 1976 study, the objective was to determine the gross structure, as well as the stereochemical nature, of the newly isolated alkaloid tiliamosine (**4.3**), $C_{36}H_{36}N_2O_6$, that possessed strong hypotensive properties. The comparison of the proton NMR spectral data of **4.3** and its derivatives with those of the two diastereoisomers tiliacorinine (**4.1**) and tiliacorine (**4.2**), $C_{36}H_{36}N_2O_5$, alkaloids of known structures revealed that **4.3**, the alkaloid possessing an extra oxygen atom, is actually a derivative of **4.1**. The methyl group situated on the nitrogen atom, present in the saturated ring D in **4.1** moves to the aromatic ring B in **4.3**. Also replacement of the aromatic hydrogen atom on ring B in **4.3** shifts to the nitrogen atom in ring D (Figure 4.1). However, more importantly, this study demonstrated that the proton NMR spectra of both **4.1** and **4.3** contain an unusual seven-

bond, through-space coupling of 0.4 Hz between the resonances of H-8' located on the ring C, and H-10' situated on the ring F. The two benzene rings C and F are separated by two sp^3 carbon atoms in both molecules (Figure 4.1).

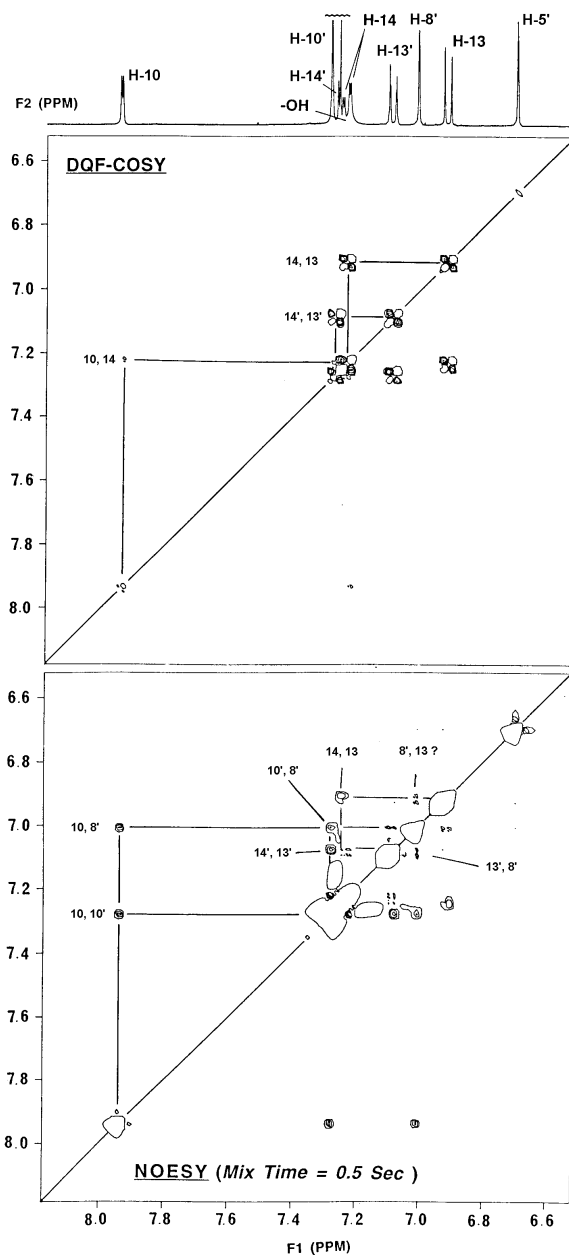

Figure 4.2 Expansion of the DQF-COSY and NOESY spectra ($CDCl_3$, 25 °C, NOESY mix time 0.5 sec) of **4.1**.

The occurrence of such an unusual coupling was established by conducting double resonance experiments on the following proton resonances: (i) when the broad doublet at $\delta = 7.61$ representing H-10' was irradiated, there was ~ 0.4 Hz decrease in line-width of the singlet at $\delta = 8.10$ which corresponds to H-8'. (ii) Conversely, there was ~ 0.4 Hz decrease in the line-width of the H-10' resonance when the H-8' signal was irradiated (Figure 4.2).

At the time of the earlier NMR investigation, it was not possible to perform analogous double-resonance experiments to observe the spin-spin interactions between H-8' and H-10' in the second diastereomer **4.2**. The close proximity and the overlap of the relevant proton signals in the 100 MHz spectrum of **4.2**, made the double-resonance experiments untenable. Hence, this interesting long range coupling study remained half-completed, dormant, and almost forgotten. Recently, the project was resurrected by subjecting **4.2**, as well as **4.1**, to 2D NMR (DQF-COSY and NOESY) examination at 400 MHz. The results of these experiments were then compared with the earlier NMR data obtained at 100 MHz.

The DQF-COSY experiments conducted on the two diastereoisomers clearly showed that: (i) there is no spin-spin interaction among the H-8' and H-10' resonances in **4.2**, and (ii) provided confirmation of the presence of spin-spin coupling between the resonance of H-8' and H-10' in **4.1**. The double-resonance experiments performed at 400 MHz also confirmed the magnitude of the long range coupling between the H-8' and H-10' resonances, as it was determined earlier at 100 MHz.

Nuclear Overhauser enhancements (NOE) at 100 MHz and the 2-D NOESY at 400 MHz (Figure 4.2) experiments conducted on the two diastereoisomers revealed close spatial relationships of the following specific aromatic protons on rings C, E and F:

4.2.1 H-8' on ring C with H-10' on ring F.

4.2.2 H-8' on ring C with H-10 on ring E.

4.2.3 H-10' on ring F with H-10 on ring E.

In compound **4.1** there is >25% NOE between H-8' and H-10', and only 12% NOE between H-8' and H-10, and none between H-10 and H-10'. In **4.2** there is almost equal NOE of 10-15% among all three protons, namely, H-8' and H-10', H-8' and H-10, and H-10 and H-10'.

An examination of the above experimental data clearly indicates that the largest NOE interaction among the aromatic ring protons occurs in **4.1**. They occur between H-8' on ring C and H-10' on ring F, thus making them very close neighbors in space. Furthermore, it is no coincidence that the 0.4 Hz long range coupling of interest occurs only in **4.1**, and it is between the resonance of the same two protons, namely, H-8' and H-10'. Now we combine these two experimental data with the unusually low field ($\delta = 8.10$) occurrence of the H-8' resonance in the tiliacorinine (**4.1**) spectrum, and can explain the occurrence of the unusual seven-bond long range coupling in the following manner.

Although in both diastereoisomers, H-8' has an oxygen function as its *ortho* neighbor, (Figure 4.1), the chemical shifts for H-8' in the two compounds are very different. In **4.2**, H-8' resonates at $\delta = 7.02$, a chemical shift position that is normal for the above mentioned chemical environment, whereas in **4.1**, the H-8' signal is at $\delta = 8.10$, an unusually low downfield position. This downfield shift of 1.08 ppm in H-8' was

attributed to the long range anisotropic deshielding effect of benzene ring F on H-8' located on ring C. This deshielding action of the aromatic ring F on H-8' suggests that H-8' on ring C and H-10' on ring F are located in an approximate 180° plane. This situation occurs only in **4.1**, and not in **4.2**. Thus when we combine the above information we can state that H-8' of ring C and H-10' of ring F are spatially very close, and there is a strong possibility of an orbital overlap between H-8' and H-10'. An orbital overlap of this type could very likely result in a through space, spin-spin coupling between the two interacting protons.^{4,5} At the time of publication, this was the first example of a through-space, seven-bond spin coupling between two aromatic protons that are located on two different benzene rings which are separated by two sp³ carbon atoms.

4.3 Molecular Modeling.

The program SYBYL[®] (Tripos Associates) version 6.4 was used to sketch the tiliacorinine molecule and to obtain several low-energy conformers. The electrostatic repulsion between H-8' on ring C and H-10' on ring F forced them to be separated more than 2.2 Å, and the bonds of the protons (cyan) with their respective rings looked bent (Figure 4.3).

By using SPARTAN[®] and correcting the geometry of this conformation the two protons became closer and the resulting distance changed to 1.84 Å (Figure 4.4). This result concluded that the protons involved with the 0.4 Hz coupling (determined by 2D NMR studies) identified as H-8' and H-10' are the same protons that are closest in space from each other through molecular modeling studies.

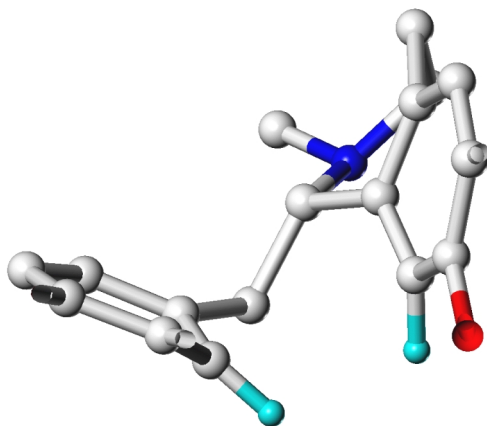

Figure 4.3 Energy-minimized structure of tiliacorinine (**4.1**) showing lack of planarity of the rings due to repulsion between protons (cyan).

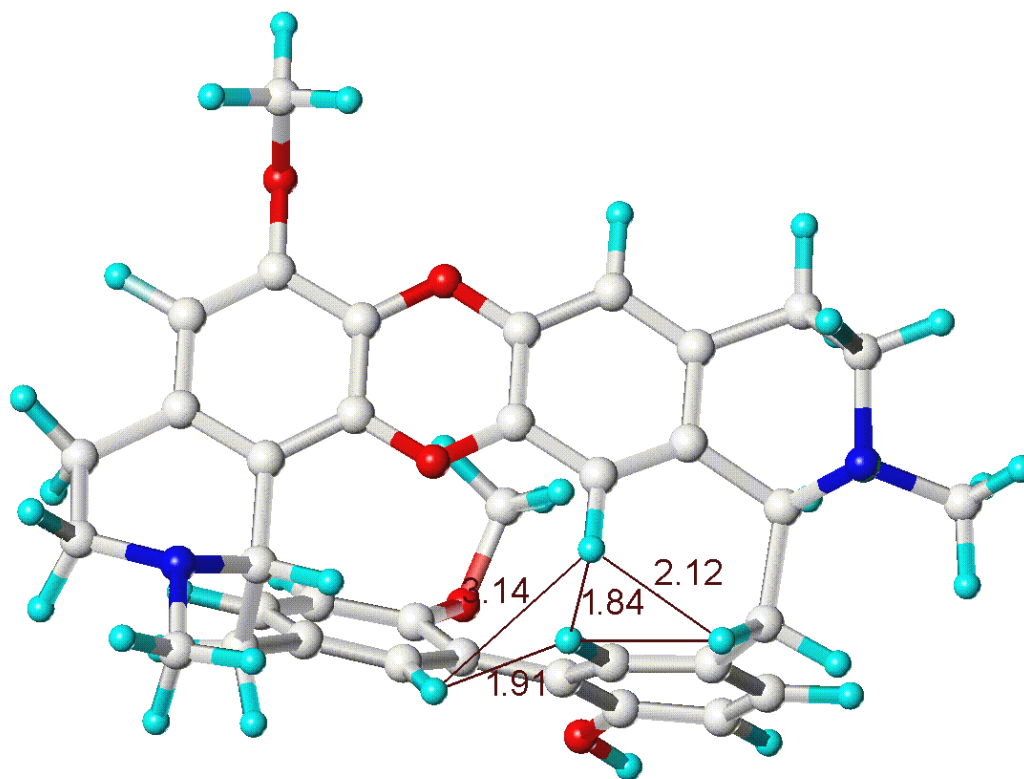

Figure 4.4 Energy-minimized structure of tiliacorinine (**4.1**) after geometry optimization showing the distances in angstroms among the protons on rings C, D, E and F. Note the short distance between H-8' and H-10' of 1.84 Å.

4.4 References:

- 4.1 For example see: Schroeder, H.; Haslinger, E. *Magn. Res. Chem.* **1994**, *32*, 12-15.
- 4.2 Bhacca, N. S.; Juneau, G. P.; Lankin, D. C.; Biswapati, M.; Deal, T.; Escobedo, J. O.; Strongin, R. M. "An Unusual Seven Bond H-H Spin Coupling," *Org. Lett.*; **2000**, *2*(24), 3813-3815.
- 4.3 Quhs, K. P.; Das, P. C.; Mukkerjee, B.; Mukkerjee, R.; Juneau, G. P.; Bhacca, N. S. *Tetrahedron Lett.* **1976**, 4241-4244.
- 4.4 A comprehensive review of the bisbenzylisoquinoline alkaloids has appeared: Schiff, P. L. *J. Nat. Prod.* **1997**, *60*, 934-953.
- 4.5 Comments on the geometric requirements in proton-proton through-space couplings are noted in reference 4.1.

CHAPTER 5

CHROMOPHORE FORMATION IN RESORCINARENE SOLUTIONS*

5.1 Introduction

This was a collaborative work with other members of my research group. My personal contribution to this project involved:

5.1.1 Molecular modeling and design of experiments.

5.1.2 Development of conditions for analysis and isolation by HPLC.

5.1.3 Synthesis and isolation of intermediates.

5.2 Background

In 1872, Baeyer studied the condensation reaction of resorcinol and benzaldehyde in acidic media.^{5.1} Upon the addition of base, the red solution he obtained turned to violet. It is now well-known that Baeyer's reaction created macrocyclic compounds now named resorcinarenes.^{5.2}

There are several recent reviews describing the importance of resorcinarenes.^{5.2} For example, resorcinarenes were the first compounds shown to bind sugars in apolar media.^{5.3} Lewis and Davis^{5.4} synthesized **5.1** and **5.2a** and investigated their properties in the presence of sugars. They observed eleven different solution colors of eleven different heated sugar solutions containing **5.1**.^{5.5} They studied neutral carbohydrates, glucose phosphates, carboxylic acid and amino sugars.

*Reprinted in part with permission from *Journal of the American Chemical Society*, 2002, Volume 124, pages 5000-5009; Ming He, Rolanda J. Johnson, Jorge O. Escobedo, Patricia A. Beck, Kyu Kwang Kim, Nadia N. St. Luce, Claude J. Davis, Patrick T. Lewis, Frank R. Fronczek, Bruce J. Melancon, Anthony A. Mrse, W. Dale Treleaven and Robert M. Strongin; Chromophore Formation in Resorcinarene Solutions and the Visual Detection of Mono- and Oligosaccharides. Copyright 2002 American Chemical Society.

The solution color changes were rapid, quantifiable and reproducible. They also showed that solutions containing **5.2b** exhibited relatively paler color changes in the presence of sugars compared to those containing boronic acids **5.1** and **5.2a** or **5.3a**.^{5,6}

Sugars are hard to analyze due to their great structural similarity as well as transparency in the visible region (they lack chromophores or fluorophores).

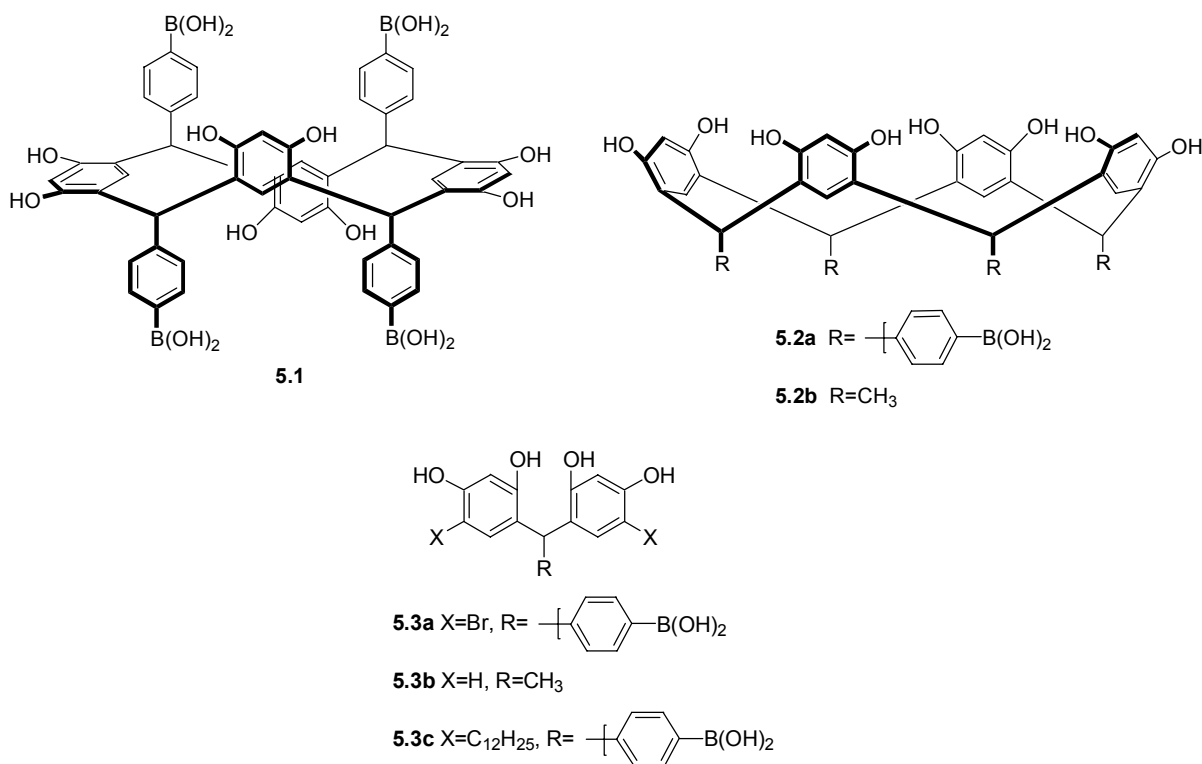

Figure 5.1 Resorcinarenes and related condensation products exhibit color changes in the presence of sugars.

In 1887, Seliwanoff reported a resorcinol color test which was followed by other resorcinol-derived methods.^{5,7} These latter and numerous other related reducing sugar assays, typically require toxic reagents, harsh and often tedious procedures.^{5,8} In the 1990's significant progress was made towards the improved selective and mild detection of monosaccharides via relatively strong solution color changes observable by visual

inspection. The recent advances were due mainly to the pioneering efforts of Shinkai and coworkers. Their studies were based primarily on aniline-functionalized azo dyes containing appended arylboronic acids.^{5.9}

Evidence that xanthenes form and serve as the active chromophores in resorcinarene solutions is presented.

5.3 The Formation and Structure of the Chromophore in Resorcinarene Solutions.

Lewis and Davis^{5.4} found that colorless DMSO solutions of freshly crystallized **5.1** or **5.2a**, (5.2 mM), upon standing in solution for several hours or upon heating at 90 °C for 1 min, developed a pinkish-purple color. The color formation was monitored via UV-vis spectroscopy. The appearance of a new λ_{max} at 535 nm was accompanied by a less intense absorbance at 500 nm.^{5.5} Initial attempts at understanding the origin of the solution color involved heating solutions of **5.1** in the dark or in O₂ degassed conditions. In both cases they found that the color intensities diminished, as evidence by both visual inspection and UV-vis spectroscopy.^{5.5} For instance, heating a solution of **5.1** (5.2 mM in DMSO) under O₂ degassed conditions led to a 61% decrease in absorbance at 536 nm. Light and O₂ apparently promote color formation. In addition, upon acylation of the phenolic hydroxyls of **5.1** and heating a DMSO solution of the resultant octaacetate to reflux, the solution remained colorless.^{5.6} The phenolic hydroxyls thus also play a key role in chromophore formation. This results suggest that the chromophore arises via oxidation of a resorcinol moiety to a quinone.^{5.5,5.6}

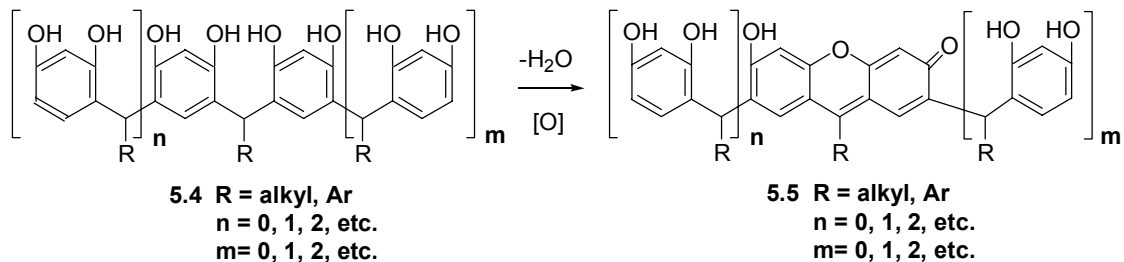

Scheme 5.1. Dehydration and oxidation of methine-bridged resorcinol oligomers leading to a xanthene.

Solutions of resorcinol or benzenboronic acid were heated separately or as an equimolar mixture using the aforementioned conditions and concentrations, with and without added monosaccharides. Only very faint solution colors were observed by visual inspection.^{5.5} This result showed that a methine-bridged resorcinol/aldehyde condensation framework was needed for effective chromophore formation and optical sugar detection. Interestingly, methine-bridged condensation product resorcinarene substructures, of which **5.3a** and **5.3b** are examples, were noted as reaction intermediates in standard xanthene dye syntheses (e.g., the transformation of **5.4** to **5.5**, $n=m=0$, Scheme 5.1).^{5.15}

Xanthenes are among the oldest known synthetic dyes such as fluorescein, rhodamine, **5.6a**, **5.6b** and many others. It has been reported that the colorimetric properties of xanthenes dyes are a function of the ionization state of the C-6 moiety^{5.16} (Figure 5.2).

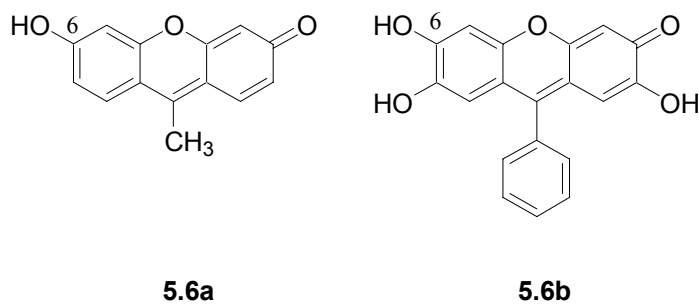

Figure 5.2 Xanthene dyes **5.6a** and **5.6b**.

5.6a and **5.6b** present two absorbance maxima in the visible region.^{5.16} The UV-vis spectrum of **5.6b** (5.0×10^{-6} M) in 9:1 DMSO:H₂O is shown in Figure 5.2. It exhibits a λ_{max} at 530 nm and a less intense λ_{max} at 500 nm. The λ_{max} absorbance values and spectral features are strikingly similar to those observed for colored DMSO solutions of **5.1** as well as **5.2a**, **5.2b** and **5.3a** previously reported.^{5.6}

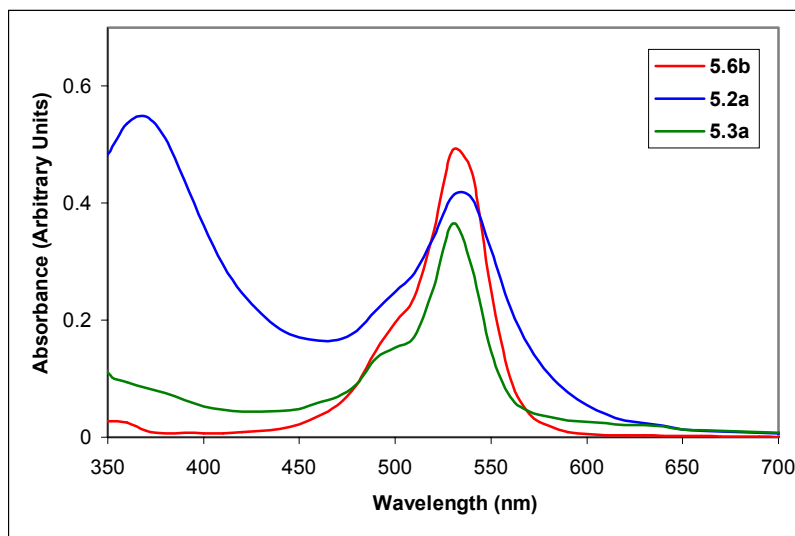

Figure 5.3 **5.2a** (1.0 mg) and **5.3a** (1.0 mg) each in 0.9 mL DMSO were heated to gentle reflux over two minutes and cooled to room temperature before 0.1 mL H₂O was added to each solution. The final concentrations of **5.2a** and **5.3a** in 9:1 DMSO:H₂O are 1.03×10^{-3} M and 1.96×10^{-3} M respectively. A solution of **5.6b** (5.0×10^{-6} M) was prepared at rt in 9:1 DMSO:H₂O.

The formation of a planar xanthene within a resorcinarene framework would lead to a considerable increase in strain energy. Computed-simulated models (Sybil 6.6) showed that in the event of the formation of a xanthene substructure within **5.2b**, an increase in strain energy of 34.2 kcal/mol would occur (Figure 5.4). Prior studies of the related calixarenes (macrocycles formally derived from phenol/formaldehyde condensations) showed that xanthenes did not form in cyclic tetrameric structures.^{5.17} Ring opening to acyclic oligomers could thus be required for xanthene formation from

resorcinarenes. It is known that the condensation reactions producing resorcinarenes are reversible under acidic conditions.^{5.2}

Weinelt and Schneider^{5.18} have reported a detailed study of the genesis of resorcinarene from resorcinol and paraldehyde under acidic conditions. They found that **5.2b** and its macrocyclic stereoisomers interconverted via the intermediacy of acyclic oligomers.

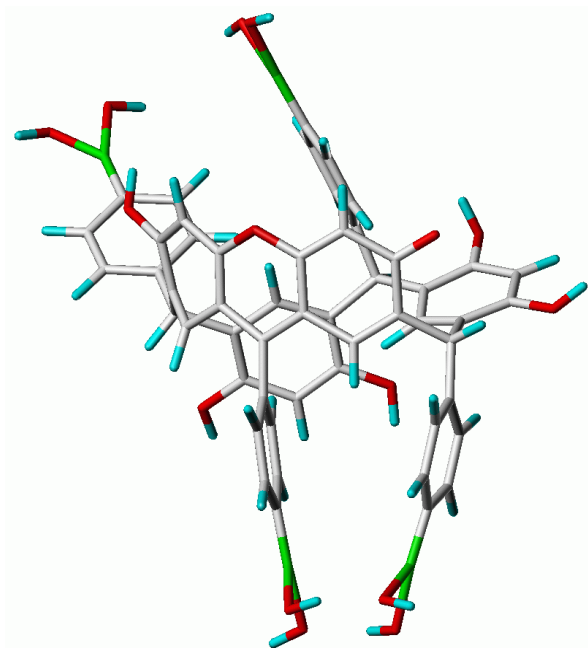
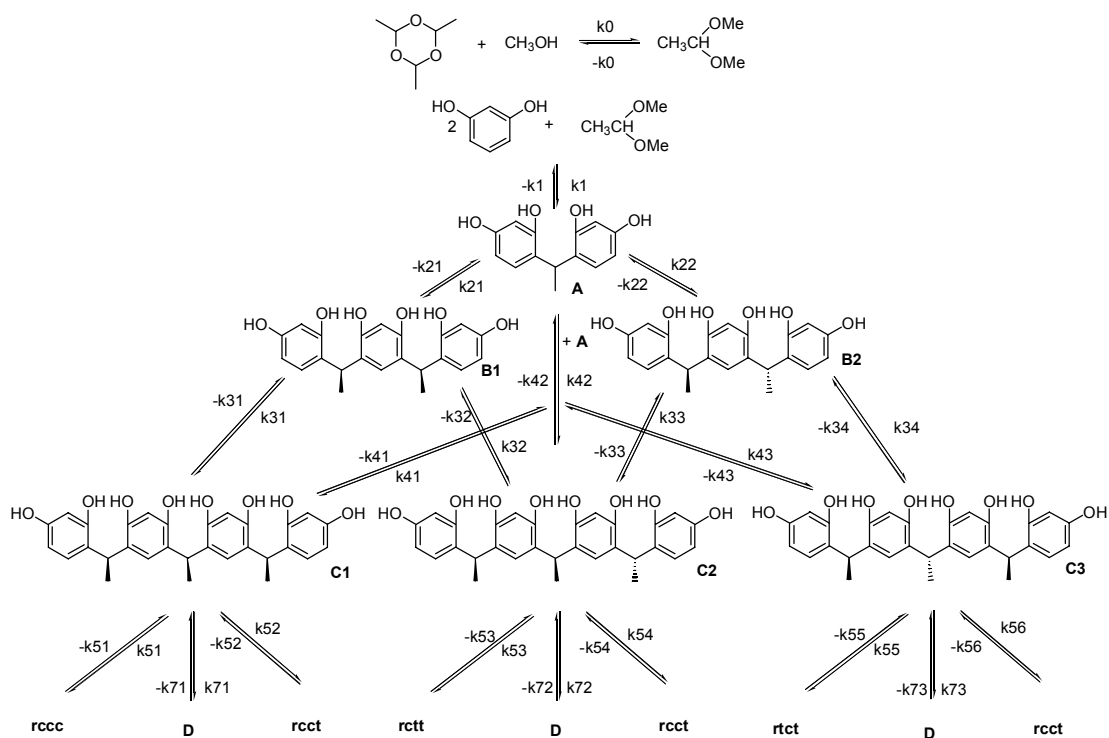

Figure 5.4 Energy-minimized structure (SYBYL[®] 6.6) of a hypothetical macrocyclic xanthene derived from **5.2b**

Their studies included the rapid quenching of the condensation reaction between resorcinol and paraldehyde in MeOH in the presence of anhydrous HCl (Scheme 5.2).



Scheme 5.2 Diagram of the reaction of paraldehyde and resorcinol showing the reversible formation of a variety of intermediates in acidic media including acyclic oligomers and resorcinarenes as reported by Weinelt and Schneider (compound **5.3b** is labeled as **A**).^{5.18}

Compound **5.3b** (r.t.=18 min) was isolated from the reaction mixture by preparative reverse-phase HPLC using a gradient water:methanol 1:1 to 100 % methanol in 20 min (Figure 5.5).

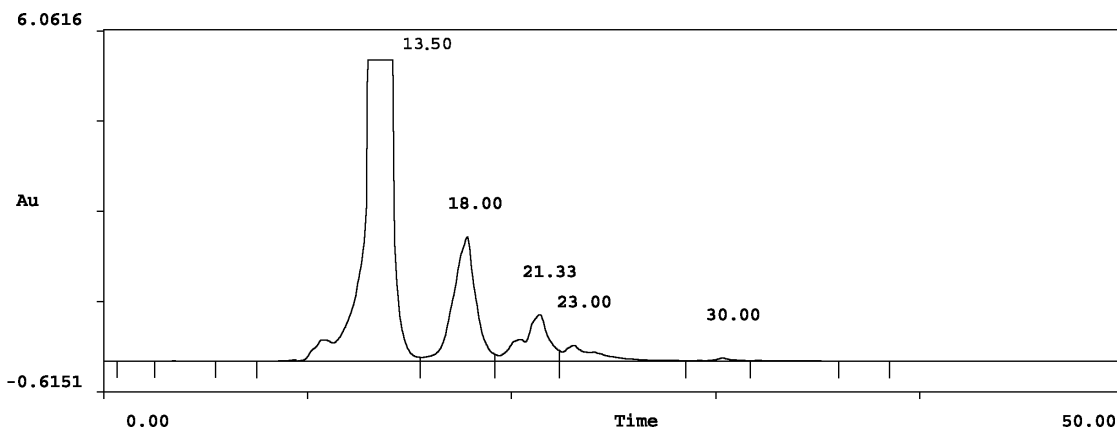

Figure 5.5 Chromatogram of a reaction of resorcinol (r.t.=13.5 min) and acetaldehyde quenched after 10 min according to the procedure reported by Weinelt and Schneider^{5.18} showing the formation of **5.3b** (r.t.=18 min).

Since the opening of a resorcinarene ring has only been previously shown to occur upon the addition of strong acid, the hypothesis of acyclic oligomer formation in aqueous or neat DMSO solutions without added acid warrants further analysis.

^1H and ^{13}C NMR spectra of DMSO- d_6 solutions of **5.1** (5.2 mM), heated at 90 °C for 3 min exhibited no readily observable change in chemical shifts or peak area integrals compared to fresh, colorless samples.^{5.5} Xanthenes are strongly absorbing materials which need be only produced in trace (ca. 0.5 % conversion) amounts to afford solution colors under our conditions.

5.4 Evidence for Acid Formation in DMSO Solutions.

Heating a DMSO (10 mL) solution of freshly recrystallized **5.2b** (100 mg, 18.4 mM) for 8 h at 120 °C followed by analysis via reversed-phase HPLC revealed the formation of numerous new products representing a 74 % conversion of **5.2b** to products based on relative peak areas. It is known that acid production from DMSO is promoted by the presence of O₂ and peroxides.^{5.19} In addition, *in situ* acid formation has been attributed as the cause of certain oxidations in DMSO.^{5.19b} The effect of O₂ on resorcinarene solution color intensity has been observed. Acid formation observed during DMSO decomposition has been inhibited by free radical scavengers.^{5.19c} Under the same thermolysis conditions as noted above, but in the presence of free radical scavengers (either BHT or phenothiazene, 10 mol %), we observe less than 28 % conversion to products by HPLC analysis.

The first X-ray crystal structure of $(\text{CH}_3)_3\text{S}^+\text{CH}_3\text{SO}_3^-$ ^{5.20} was obtained from a thermolysis reaction of **5.2b** in DMSO. It is known that $(\text{CH}_3)_3\text{S}^+\text{CH}_3\text{SO}_3^-$ forms, along with $\text{CH}_3\text{SO}_3\text{H}$, $\text{CH}_3\text{SO}_2\text{H}$ and CH_3SOH (and several other products) via the radical and

acid promoted decomposition of DMSO.^{5.21} These results confirm that strong acids are formed during the thermolysis of DMSO in the presence of O₂.

5.5 Macrocycle Bond Breaking and Oxidation of the Acyclic Products.

Compound **5.7** (Figure 5.6), a rarely observed resorcinarene stereoisomer,^{5.22} was isolated in 2.3 % yield from the thermolysis of **5.2b** in DMSO, via flash column chromatography. The structure of **5.7** was previously assigned (as the octabutyrate derivative) via NMR evidence during the acid-catalyzed condensation/isomerization studies of Schneider.^{5.18} Importantly, stereoisomer **5.7** can only form from **5.2b** via bond rupture and reformation.^{5.18} If **5.7** were a conformer of **5.2b**, the methyl group (C18), would reside outside, rather than above the plane of the macrocycle cavity.

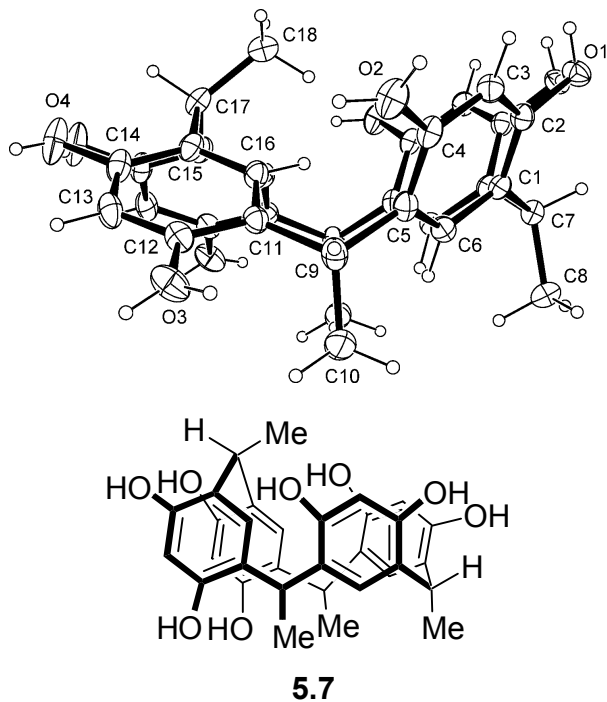

Figure 5.6 Compound **5.7** and ORTEP.

Acyclic products were observed during the thermolysis of **5.2b**. A key product, **5.3b** (also labeled as **A** in Scheme 5.2) was isolated from a broad HPLC fraction eluting from 16-19 min (Figure 5.7).

The ^1H NMR spectrum of the isolate exhibits several peaks including each of the resonances associated with **5.3b**^{5,18} (CH_3OD δ 1.46, d, $^3J = 7.3$ Hz, 4.53, q, $^3J = 7.3$ Hz, 6.18-6.22, m, 6.89, d, $^3J = 8.0$ Hz). Overlay of the ^1H NMR spectrum of the HPLC isolate with a sample of independently synthesized and isolated **5.3b** confirms the assignment (Figure 5.8). In addition, the MALDI MS of the HPLC fraction contains a peak at 245.59 amu (246.26 amu calcd). The production of compounds **5.3b** and **5.7** under our conditions constitutes an important initial link between our investigations and the prior acid-catalyzed macrocycle genesis mechanism studies.^{5,18}

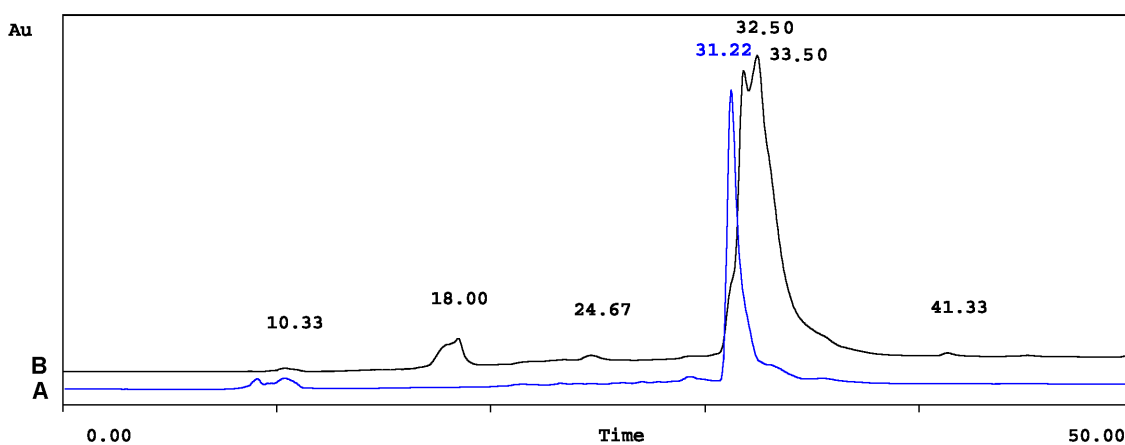

Figure 5.7 (A) Chromatogram of **5.2b** (Control); (B) Chromatogram of the thermolysis products of **5.2b** showing also the formation of **5.3b**.

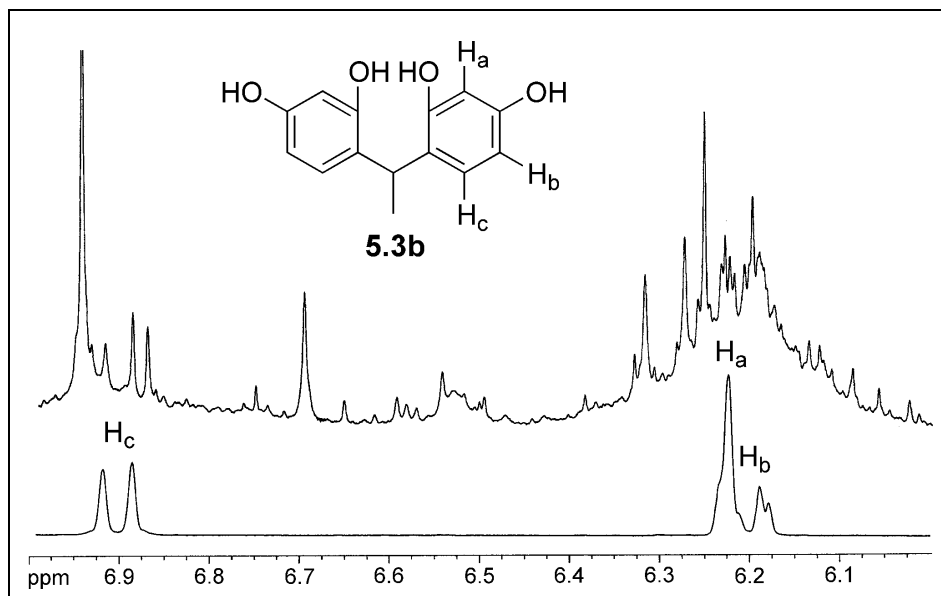

Figure 5.8 Top: expansion of a ^1H NMR spectrum of semipurified thermolysis reaction products of **5.2b** showing the formation of **5.3b**. Bottom: expansion of a ^1H NMR spectrum of pure **5.3b**.

More evidence for higher order oligomer production under our conditions was found involving thermolysis of **5.2b** in DMSO. At least five sets of doublets appear between 0.72 and 1.53 ppm in the ^1H NMR of each of two flash column fractions (TLC $R_F=0.54$ and 0.63 , 9:1 $\text{CH}_2\text{Cl}_2:\text{CH}_3\text{OH}$, δ 1.53, 1.08, 1.01, 0.97, 0.83, 0.72 ppm, and δ : 1.29, 1.15, 1.00, 0.89, 0.84 ppm, CH_3OD , respectively). In addition, the MALDI mass spectrum (anthracene matrix) of other fractions ($R_F=0.29$ and 0.44) exhibit peaks for higher homologues of **5.3b** (entries 1 and 2, Table 5.1). MALDI MS evidence also suggests the formation of xanthene materials not previously reported in previous fragmentation and equilibration studies of **5.2b** (entries 3-6, Table 5.1).^{5.23, 5.24}

Table 5.1. MALDI MS Evidence for the Formation of Acyclic Oxidized and Unoxidized Products from the Thermolysis of **5.2b**

| Entry | Structure | TLC R _F | (<i>m/z</i>) calcd | (<i>m/z</i>) obsd |
|-------|-----------------------------|--------------------|----------------------|---------------------|
| 1 | 5.4 , R=Me, m=1, n=0 | 0.29 | 382.41 | 381.89 |
| 2 | 5.4 , R=Me, m=3, n=2 | 0.44 | 926.36 | 926.28 |
| 3 | 5.6a | 0.44 | 226.23 | 225.61 |
| 4 | 5.5 , R=Me, m+n=4 | 0.26 | 906.01 | 906.33 |
| 5 | 5.5 , R=Me, m+n=3 | 0.84 | 770.79 | 770.82 |
| 6 | 5.5 , R=Me, n=1, m=0 | 0.79 | 362.51 | 361.38 |

Heating an air saturated solution of **5.3b** (0.880 g, 3.576 mmol) dissolved in DMSO (78 mL) at 100 °C for 28 h leads to the formation of several products. The complex ¹H NMR of the crude mixture reveals the presence of resorcinol as the predominant (90 %) product as well as minor conversion to 2',4'-dihydroxy-acetophenone **5.8** (ratio of integrals of resorcinol triplet 6.94 ppm to **5.8** doublet at 7.76 ppm is 153:1, CH₃OD) and very small traces of xanthene **5.6a** (d, 7.65 ppm).

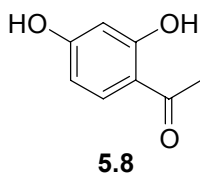

Figure 5.9 2',4'-Dihydroxyacetophenone (**5.8**) formed upon oxidation of a DMSO solution of **5.3b**.

The production of resorcinol and **5.8** (Figure 5.9) is consistent with the reversible opening and fragmentation of the resorcinarenes in acidic media.^{5,18} Furthermore, in acidic media, the addition of water at the methine carbon of **5.4** (R=Ar, n=0, m=0) followed by

elimination has been described as an intermediate step in the synthesis of xanthenes.^{5.26} Better conversion to xanthene **5.6a** from **5.3b** was attained by limiting thermolysis time to 2 h. The ¹H NMR spectrum (DMSO-*d*₆) of the crude reaction mixture clearly shows a doublet at 7.65 ppm characteristic of **5.6a** with improved S/N compared to the 28 h experiment (*vide supra*). Resonances centered at 5.26, 6.49 and 6.60 ppm are also discernable, overlaying with the ¹H NMR of an analytical sample^{5.26} of **5.6a**. Since oxidation to xanthenes can be promoted by peroxides and acid.^{5.26, 5.27} Heating a solution of **5.3b** (50 mg, 0.203 mmol), H₂SO₄ (0.15 mL) and K₂S₂O₈ (1.0 mg) in 1.5 mL MeOH at reflux for 2 h produces the most significant conversion (4 % yield) of **5.3b** to **5.6a** observed to date (Figure 5.10).

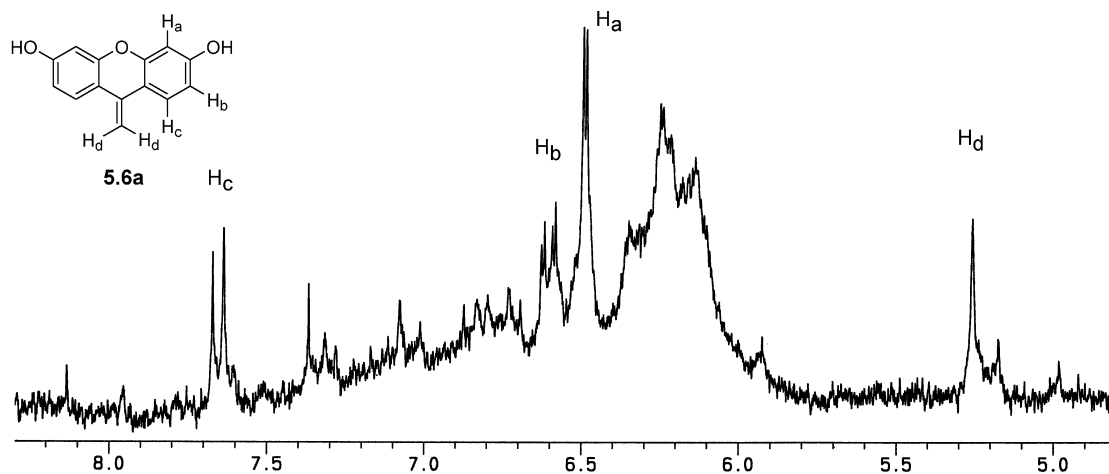

Figure 5.10 ¹H NMR of the products of oxidation of **5.3b** showing the formation of **5.6a** (as its tautomer).

It has been now demonstrated that xanthenes form in solutions containing resorcinarene macrocycles (Scheme 5.1). The O₂-induced radical decomposition of DMSO leads to *in situ* strong acid formation. The acid catalyzes a reverse condensation reaction to afford acyclic oligomers. The acyclic oligomers undergo oxidation also via the action of acid and peroxide.

5.6 Conclusion

Strong evidence that the color observed in Baeyer's initial resorcinarene condensation reaction^{5.1} was due to the presence of xanthenes has been presented. Interestingly, Fischer, who won the Nobel Prize for sugar research, presented his doctoral thesis to Baeyer in 1874 on fluorescein and orcinol dyes.^{5.29}

It has been shown that the colored products existing in solutions of resorcinarene macrocycles can serve as colorimetric indicators. The main finding of the present study is the determination of the origin and structure of the active chromophores.

The investigation of the colorimetric and fluorimetric properties of resorcinarenes, xanthenes and related chromophoric materials is ongoing in our laboratory. Xanthene dyes containing well-positioned boronic acid or related binding moieties should find application as powerful receptors for saccharides and other polar analytes such as carboxylates and phosphates.

The resorcinarenes, however, do offer potential advantages compared to functionalized dye materials. A great attraction is their ease of synthesis in one step on ca. 200 g scale.^{5.2d} Having addressed many of the main mechanistic issues associated with the colorimetric sugar detection process, we are now also focusing on the study and optimization of important applied sensing parameters such as detection selectivity, sensitivity and reversibility in aqueous and biological media.

5.7 Experimental Section

- **General.** Matrix Assisted Laser Desorption Ionization mass spectra were acquired using a Bruker Proflex III MALDI mass spectrometer with either anthracene or dithranol matrices. FT-IR spectra were recorded at room temperature on a Perkin-Elmer 1760X FT-IR spectrophotometer. UV-Visible spectra were recorded at room temperature

on a Spectramax Plus (Molecular Devices). Analytical thin-layer chromatography (TLC) was performed using general purpose silica gel on glass (Scientific Adsorbants). Flash chromatography columns were prepared with silica gel (Scientific Adsorbants, 32-63 μm particle size, 60 \AA). Analytic and preparative-scale HPLC were performed on a CM4000 multiple solvent delivery system (Milton Roy) and a Spectromonitor 5000 photodiode array detector (LDC Analytical) using a Dynamax 60 \AA C18 (21.4 mm ID x 25 cm L) with a flow rate of 5 mL/min. and a gradient of 50% water/MeOH to 100% MeOH in 20 min. unless otherwise stated. The following compounds were prepared according to literature methods: **5.1**,^{5.4} **5.2a**,^{5.4} **5.2b**,^{5.32} **5.3a**,^{5.6} **5.3b**,^{5.18} and **5.6a**.^{5.15} Isotopically labeled D-fructose-2-¹³C was purchased from Isotec. All other chemicals were purchased from Sigma or Aldrich and used without further purification. Proton NMR spectra were acquired in either CD₃OD, CH₃OD or DMSO-*d*₆ on a Bruker DPX-250, DPX-400, or AMX-500 spectrometer. All δ values are reported with (CH₃)₄Si at 0.00 ppm or DMSO at 2.45 ppm as references.

- **X-ray crystallographic data.** Intensity data were collected on a Nonius Kappa CCD diffractometer equipped with MoK α radiation and a graphite monochromator. The sample was cooled to 120 K by an Oxford Cryosystems Cryostream chiller. Data collection parameters and crystallographic data are provided in Supporting Information. Absorption and decay effects were negligible. The structure was solved by direct methods, using SIR97³⁰ and refined using SHELXL97.³¹ H atoms were observed in difference maps, but were constrained to be in idealized positions in the refinement. OH hydrogen atoms are all disordered into two sites, all of which were treated as half

populated. O-H distances were constrained to be 0.84 Å, but otherwise, these H positions were refined.

5.8 References

- 5.1 (a) Baeyer, A. *Ber. Dtsch. Chem. Ges.* **1872**, 5, 25. (b) Baeyer, A. *Ber. Dtsch. Chem. Ges.* **1872**, 5, 280.
- 5.2 (a) Schneider, H.-J.; Schneider, U. *J. Inclusion Phenom.* **1994**, 19, 67. (b) *Container Molecules and Their Guests*, Cram, D. J.; Cram, J. M., The Royal Society of Chemistry: Cambridge, U.K. 1994. (c) Sherman, J. C. *Tetrahedron* **1995**, 51, 3395. (d) Timmerman, P.; Verboom, W.; Reinhoudt, D. N. *Tetrahedron* **1996**, 52, 2663. (e) Jasat, A.; Sherman, J. C. *Chem. Rev.* **1999**, 99, 931. (f) Rudkevich D. M.; Rebek, J. *Eur. J. Org. Chem.* **1999**, 9, 1991.
- 5.3 Aoyama, Y.; Tanaka, Y.; Sugihara, S. *J. Am. Chem. Soc.* **1989**, 111, 5397.
- 5.4 Lewis, P. T.; Davis, C. J.; Saraiva, M.; Treleaven, W. D.; McCarley, T. D.; Strongin, R. M. *J. Org. Chem.* **1997**, 62, 6110.
- 5.5 Davis, C. J.; Lewis, P. T.; McCarroll, M. E.; Read, M. W.; Cueto, R.; Strongin, R. M. *Org. Lett.* **1999**, 1, 331.
- 5.6 Lewis, P. T.; Davis, C. J.; Cabell, L. A.; He, M.; Read, M. W.; McCarroll, M. E.; Strongin, R. M. *Org. Lett.* **2000**, 2, 589.
- 5.7 For example: (a) Seliwanoff, T. *Chem. Ber.* **1887**, 20, 181. (b) Bial, M. *Dtsch. Med. Wehschr.* **1902**, 253. (c) Kulka, R. G. *Biochem J.* **1956**, 63, 542.
- 5.8 Chaplin, M. F. "Monosaccharides," in *Carbohydrate Analysis. A Practical Approach* Chaplin, M. F.; Kennedy, J. F., Eds., Oxford University Press, Oxford, 1994, p 1-40.
- 5.9 Review: (a) James, T. D.; Samankumara Sandanayake, K. R. A. S.; Shinkai, S. *Angew. Chem. Int. Ed. Engl.* **1996**, 35, 1910. More recent examples of boronic acid-based dyes and optical sensing of neutral sugars: (b) Koumoto, K.; Takeuchi, M.; Shinkai, S. *Supramol. Chem.* **1998**, 9, 203. (c) Koumoto, K.; Shinkai, S. *Chem. Lett.* **2000**, 856. (d) Ward, C. J.; Patel, P.; Ashton, P. R.; James, T. D. *Chem. Commun.* **2000**, 229. (d) DiCesare, N.; Lakowicz, J. R. *Org. Lett.* **2001**, 3, 3891.
- 5.10 Recent examples: a) Bertozzi, C. R.; Kiessling, L. L. *Science* **2001**, 291, 2357. (b) Axford, J. *Trends Immunol.* **2001**, 22, 237, and references cited therein.

- 5.11 Solution color changes in response to monosaccharides, maltose, maltotriose and maltotetraose using a resorcinarene-methyl red dye competition process: Rusin, O.; Kral, V. *Tetrahedron Lett.* **2001**, *42*, 4235.
- 5.12 Kennedy, J. F.; Pagliuca, G. "Oligosaccharides," in *Carbohydrate Analysis. A Practical Approach* Chaplin, M. F.; Kennedy, J. F., Eds., Oxford University Press, Oxford, 1994, p 46-62.
- 5.13 Review: LoGuidice, J. M.; Lhermitte, M. *Biomed. Chromatogr.* **1996**, *10*, 290.
- 5.14 Davis, C. J.; Lewis, P. T.; Billodeaux, D. R.; Fronczek, F. R.; Escobedo, J. O.; Strongin, R. M. *Org. Lett.*, **2001**, *3*, 2443.
- 5.15 Sen, R. N.; Sinha, N. N. *J. Am. Chem. Soc.* **1923**, *45*, 2984.
- 5.16 Gupta, S. N.; Linden, S. M.; Wrzyszczyński, A.; Neckers, D. C. *Macromolecules*, **1988**, *21* 51.
- 5.17 Agbaria, K.; Biali, S. E. *J. Org. Chem.* **2001**, *66*, 5842.
- 5.18 Weinelt, F.; Schneider, H.-J. *J. Org. Chem.* **1991**, *56*, 5527.
- 5.19 (a) Gillis, B. T.; Beck, P. E. *J. Org. Chem.* **1963**, *28*, 1388. (b) Santusosso, T. M.; Swern, D. *Tetrahedron Lett.* **1974**, 4255. (c) Emert, J.; Goldenberg, M.; Chiu, G. L. *J. Org. Chem.* **1977**, *42*, 2012.
- 5.20 Fronczek, F. R.; Johnson, R. J.; Strongin, R. M. *Acta Cryst.* **2001**, *E5*, o447-o448.
- 5.21 (a) Chen, C.-T.; Yan, S.-J. *Tetrahedron Lett.* **1969**, 3855. (b) Head, D. L.; McCarty, C. G. *Tetrahedron Lett.* **1973**, 1405.
- 5.22 For the structures of the different possible resorcinarene stereoisomers see reference 5.3d.
- 5.23 In the previous work (reference 5.19), acyclic oligomeric products (**5.3b** and two stereoisomeric trimeric compounds, three resorcinol rings, **5.4**, R=Me, m=1, n=0, Scheme 5.1) were isolated and characterized. Higher order acyclic oligomers (e.g., pentamers and hexamers) were also observed as major reaction products. Methyl ¹H NMR resonances, appearing as several doublets between 0.7 and 2.0 ppm (CH₃OD) that corresponded to neither **5.3b**, **5.4** (R=Me, m=1, n=0), or resorcinarene macrocycles, thus were assigned to acyclics with five or more resorcinol moieties.
- 5.24 Flash column chromatography and TLC analysis of the thermolysis products of **5.2b** were complicated by the multiple product formation and fraction streaking.
- 5.25 Fronczek, F. R.; St. Luce, N. N.; Strongin, R. M. *Acta Cryst.*, **2001**, *C57*, 1423.

- 5.26 Sen, R. N.; Sarkar, N. N. *J. Am. Chem. Soc.* **1925**, *47*, 1079.
- 5.27 Deno, N. C.; Booker, E. L.; Kramer, K. E.; Saines, G. *J. Am. Chem. Soc.* **1969**, *91*, 5237.
- 5.28 Arts, S. J. H. F.; Mombarg, E. J. M.; van Bekkum, H.; Sheldon, R. A. *Synthesis* **1997**, 597.
- 5.29 Fischer, E. Ph.D. Dissertation, Strasbourg University, Strasbourg, France, 1874
- 5.30 Altomare, A., Burla, M. C., Camalli, M., Cascarano, G. L., Giacovazzo, C., Guagliardi, A., Moliterni, A. G. G., Polidori, G. & Spagna, R. *J. Appl. Cryst.* **1999**, *32*, 115.
- 5.31 Sheldrick, G. SHELXL97, University of Göttingen, Germany, 1997.
- 5.32 (a) Niederl, J. B.; Vogel, H. *J. Am. Chem. Soc.* **1940**, *62*, 2512. (b) Erdtmann, H.; Hoegberg, S.; Abramsson, S.; Nilsson, B. *Tetrahedron Lett.* **1968**, 1679. (c) Nilsson, B. *Acta Chem. Scand.* **1968**, 22732. (d) Cram, D. J.; Karbach, S.; Kim, H.-E.; Knobler, C. B.; Maverick, E. F.; Eriscon, J. L.; Helgeson, R. C. *J. Am. Chem. Soc.* **1988**, *110*, 2229.

CHAPTER 6

INVESTIGATION OF THE [60]FULLERENE PHOTOOXIDATION REACTION FOR THE PRESENCE OF THE [5,6]-OPEN OXIDOANNULENE C₆₀O ISOMER*

6.1 Introduction.

The study of fullerene oxides has been an active area of research for over a decade. In 1991 Diederich reported the isolation of minor amounts of C₇₀O from a fullerene synthesis reaction involving the resistive heating of graphite.^{6.1} Wood observed C₆₀O under similar fullerene production conditions.^{6.2} Thorpe showed that oxides of [60]fullerene containing up to four oxygen atoms could be generated electrochemically.^{6.3} In 1992, Smith and co-workers reported the first controlled synthesis, isolation and characterization of C₆₀O via the photooxygenation of [60]fullerene.^{6.4} The structure (6.1) was unambiguously assigned as the epoxide based on detailed spectroscopic evidence. Balch later reported the single crystal X-ray structure of an organometallic derivative of 6.1 which exhibited the epoxide moiety.^{6.5}

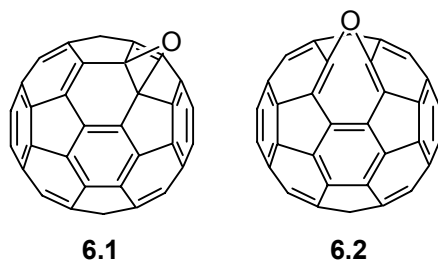

Figure 6.1 Structures of the two possible isomers of C₆₀O: epoxide (6.1) and oxidoannulene (6.2).

*Reprinted in part with permission from *Tetrahedron Letters*, 2002, Volume 43, No. 35, pages 6117-6119; Jorge O. Escobedo, Amy E. Frey and Robert M. Strongin; Investigation of the [60]fullerene photooxidation reaction for the presence of the [5,6]-open oxidoannulene C₆₀O isomer. Copyright 2002 Elsevier Science.

In 2001 Weisman et al. reported the first synthesis and isolation of the [5,6]-open C₆₀O annulene **6.2** (oxa-homo[60]fullerene) isomer.⁶ They obtained **6.2** upon photolysis of C₆₀O₃,⁷ the [60]fullerene [6,6]-closed ozonide. They also found that C₆₀O₃ converts to **6.1** upon thermolytic loss of O₂. The researchers postulated that oxidoannulene **6.2** may have been present as an undetected contaminant in previous work involving epoxide **6.1**. They stated that a reevaluation of prior research involving **6.1** was thus warranted. This prompted us to undertake the current study.

Since the 1992 photooxygenation reaction,^{6,4} epoxide **6.1** has been synthesized and isolated via methods including the reaction of [60]fullerene with dimethyldioxirane,^{6,8} O₃,^{6,9} and MCPBA.^{6,10} Compound **6.1** has served as a substrate for novel fullerene chemistry^{6,11} and has been of long-standing interest due to its unique physical and materials properties.^{6,12} Importantly, if **6.2** has gone undetected in known [60]fullerene epoxidation reactions it could thus potentially impact a number of extensive prior efforts. Isomers **6.1** and **6.2** were reported to display significant overlap on columns routinely used to separate fullerenes.^{6,6} Specific details concerning the analysis of a mixture of **6.1** and **6.2** are not currently known.

6.2 Results and Discussion

Photooxygenation of [60]fullerene (24 mM, 10-15% randomly enriched with carbon-13) in an oxygenated benzene (200 mL) solution containing benzil (0.2 equiv) for 8 h led to ca. 25 % conversion to **6.1**, based on its HPLC integral area ratio to unreacted [60]fullerene. In order to observe all possible products, the crude mixture was concentrated and not subjected to any purification steps. The mixture was dissolved in a 1:1 mixture of *o*-dichlorobenzene-*d*₄ and toluene-*d*₈ (the same solvent mixture used to

acquire the NMR spectrum of **6.2**^{6.6}) for analysis via 125 MHz ¹³C NMR. After 40,960 scans (5.00 second delay time) sixteen intense resonances corresponding to **6.1** were identified. We expanded regions of the spectrum where resonances corresponding to **6.2** would not overlap with those of **6.1**. For instance, according to the published spectrum,^{6.13} compound **6.2** exhibits fifteen resonances between 137.2 ppm and 139.6 ppm. The NMR spectrum of the crude photooxygenation reaction product displays only one resonance in this region (137.4 ppm) which overlaps with a resonance of **6.2**. In addition, peaks at 151.9, 147.8, 144.1, 143.8, 143.5, 143.4, 141.0 and several resonances appearing between 134.7 and 136.4 corresponding to **6.2** are not observed in the NMR spectrum of the crude photooxygenation mixture. Compound **6.2** is thus not detected in the [60]fullerene photooxygenation reaction by ¹³C NMR.

In order to confirm the NMR results mixtures of **6.1** and **6.2** were analyzed by HPLC. First, a standard sample of **6.2** was prepared for analysis according to the reported method^{6.6} via ozonation of [60]fullerene (5 mM) in *o*-xylene at -16 °C in the dark for 7 min, followed by purging with N₂. The [60]fullerene monoozonide eluted at 12.3 min on a Cosmosil Buckyprep column (4.6 x 250 mm, toluene mobile phase, 1 mL/min, λ=330 nm, 0 °C). The ozonide solution was cooled to -16 °C and irradiated with a fluorescent desk lamp for several min. The irradiation was stopped after ca. 95 % conversion, based on HPLC peak areas, to **6.2** which had a 9.3 min retention. Carbon-13 NMR analysis of a crude ozonation/photolysis reaction mixture confirmed the production of **6.2**.

In order to study mixtures of the two oxide isomers with a HPLC mobile phase gradient (1:1 toluene:hexane to 100 % toluene over 20 min, rt), **6.2** elutes at 17.1 min and

6.1 elutes at 17.6 min. We found no trace of **6.2** in the crude photooxygenation reaction mixture via HPLC. In order to verify the HPLC results, we collected the first ca. 25 % of the epoxide eluent. This latter fraction of **6.1** exhibited no trace of **6.2** via HPLC. The first 25 % of this early eluting fraction was then collected and reinjected. No trace of **6.2** was thus observed, even after a double recycle of epoxide-containing forerun material (Figure 6.2).

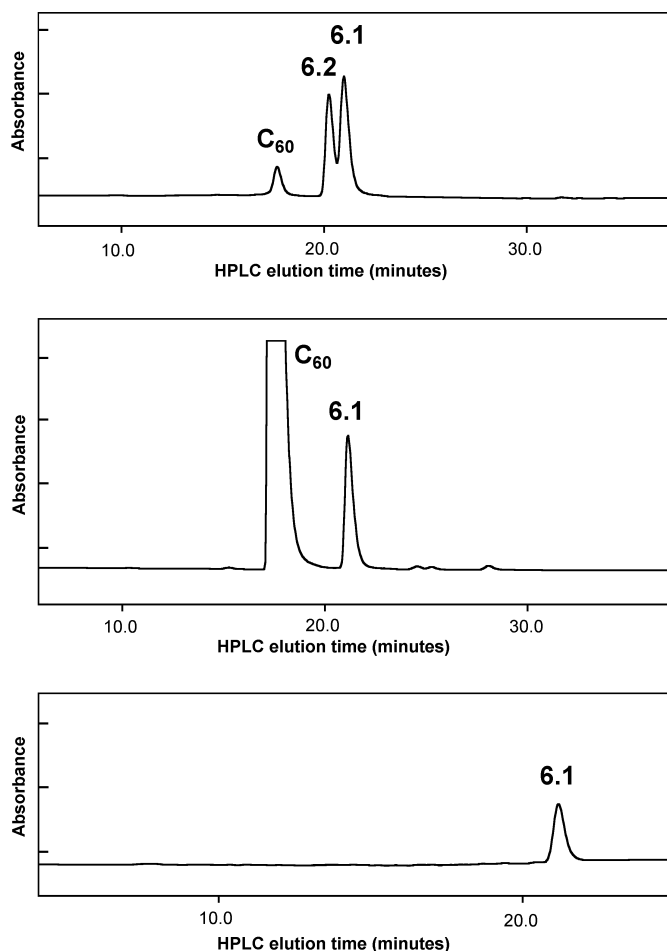

Figure 6.2. HPLC traces: a prepared mixture of [60]fullerene, **6.1** and **6.2** (top), the crude reaction mixture obtained via the photolysis of [60]fullerene in an O₂-saturated benzene solution containing benzil (middle) and recycled epoxide **6.1** early-eluting fractions from the [60]fullerene photolysis reaction (bottom).

The [60]fullerene ozonide is analogous to the dipolar cycloadducts formed via the reaction of [60]fullerene and diazoalkanes or azides. These latter materials, upon loss of

N₂, typically afford [6,6]-open and/or [6,5]-closed cyclopropane or annulene (homofullerene) one atom bridged isomers, depending on reaction conditions.^{6,14} Thermolysis of C₆₀O₃ leads to **6.1**. Photolytic extrusion of O₂ from the [60]fullerene ozonide affords **6.2**. To date, it is the only known reaction in which [6,5]-open **6.2** has been observed experimentally directly from [60]fullerene starting material.^{6,15}

6.3 Conclusion.

In summary, carbon-13 labeling along with ¹³C NMR spectroscopy and an HPLC mobile phase gradient technique were used to analyze [60]fullerene monooxide isomers. No trace of oxidoannulene **6.2** was found in the singlet oxygen sensitized photolysis of [60]fullerene, a major preparative method used for the synthesis and study of epoxide **6.1**.

6.4 References.

- 6.1 Diederich, F.; Ettl, R.; Rubin, Y.; Whetten, R. L.; Beck, R.; Alvarez, M.; Anz, S.; Sehsharma, D.; Wudl, F.; Khemani, K. c.; Koch, A. *Science* **1991**, *252*, 548.
- 6.2 Wood, J. M.; Kahr, B.; Hoke, S. H., II; Dejarme, L.; Cooks, R. G.; Ben-Amotz, D. *J. Am. Chem. Soc.* **1991**, *113*, 5907.
- 6.3 Kalsbeck, W. A.; Thorpe, H. H. *J. Electroanal. Chem.* **1991**, *314*, 363.
- 6.4 Creegan, K. M.; Robbins, J. L.; Win, K.; Millar, J.; Sherwood, R. D.; Tindall, P. J.; Cox, D. M.; Smith, A. B., III; McCauley, J. P., Jr.; Jones, D. R.; Gallagher, R. T. *J. Am. Chem. Soc.* **1992**, *114*, 1103.
- 6.5 Balch, A. L.; Costa, D. A.; Lee, J. W.; Noll, B. C.; Olmstead, M. M. *Inorg. Chem.* **1994**, *33*, 2071.
- 6.6 Weisman, R. B.; Heymann, D.; Bachilo, S. M. *J. Am. Chem. Soc.* **2001**, *123*, 9720.
- 6.7 Heymann, D.; Bachilo, S. M.; Weisman, R. B.; Cataldo, F.; Fokkens, R. H.; Nibbering, N. M. M.; Vis, R. D.; Chibante, L. P. F. *J. Am. Chem. Soc.* **2000**, *122*, 11473.
- 6.8 Elmes, Y.; Silverman, S. K.; Sheu, C.; Kao, M.; Foote, C. S. *Angew. Chem., Int. Ed. Engl.* **1992**, *31*, 351.

- 6.9 (a) Heymann, D.; Chibante, L. P. F. *Chem. Phys. Lett.* **1993**, *207*, 339. (b) Malhotra, R.; Kumar, S.; Satyam, A. *J. Chem. Soc., Chem. Commun.* **1994**, 1339.
- 6.10 Balch, A. L.; Costa, D. A.; Noll, B. C.; Olmstead, M. M. *J. Am. Chem. Soc.* **1995**, *117*, 8926.
- 6.11 Precursor to odd-numbered carbon clusters and isolated dimeric fullerenes, for example: (a) McElvany, S. W.; Callahan, J. H.; Ross, M. M.; Lamb, L. D.; Huffman, D. R. *Science* **1993**, *260*, 1632. (b) Deng, J.-P.; Ju, D. D.; Her, G.-R.; Mou, C.-Y.; Chen, C.-J.; Lin, Y.-Y.; Han, C.-C. *J. Phys Chem.* **1993**, *97*, 11575. (c) Taylor, R. *J. Chem. Soc., Chem. Commun.* **1994**, 1629. (d) Beck, R. D.; Brauchle, G.; Stoermer, C.; Kappes, M. M. *J. Chem. Phys.* **1995**, *102*, 540. (e) Smith, A. B., III; Tokuyama, H.; Strongin, R. M.; Furst, G. t.; Romanow, W. J.; Chait, B. T.; Mizra, U. A.; Haller, I. *J. Am. Chem. Soc.* **1995**, *117*, 9359. (f) Lebedkin, S.; Ballenweig, S.; Gross, J.; Taylor, R.; Krätschmer, W. *Tetrahedron Lett.* **1995**, *36*, 4971.
- 6.12 For example: (a) Vaughan, G. B. M.; Heiney, P. A.; McGhie, A. R.; Jones, D. R.; Strongin, R. M.; Cichy, M. A.; Smith, A. B., III *Chem. Phys.* **1992**, *168*, 185. (b) Cheng, A.; Klein, M. I. *J. Chem. Soc., Faraday Trans.* **1992**, *88*, 1949. (c) Maliszewskij, N. C.; Heiney, P. A.; Jones, D. R.; Strongin, R. M.; Cichy, M. A.; Smith, A. B. *Langmuir* **1993**, *9*, 1439. (d) Cheng, A.; Klein, M. I. *J. Chem. Soc., Faraday Trans.* **1994**, *90*, 253. (e) Fedurco, M.; Costa, D. A.; Balch, A. I.; Fawcett, W. R. *Angew. Chem., Int. Ed. Engl.* **1995**, *34*, 194. (f) Meingast, C.; Roth, G.; Pintschovius, L.; Michel, R. H.; Stoermer, C.; Kappes, M. M.; Heiney, P. A.; Brard, L.; Strongin, R. M.; Smith, A. B., III *Phys. Rev. B* **1996**, *54*, 124. (g) Illescas, B. M.; Martin, N. *J. Org. Chem.* **2000**, *65*, 5986.
- 6.13 See reference 6, Supporting Information.
- 6.14 For example: (a) Diederich, F.; Isaacs, L.; Philp, D. *Chem. Soc. Rev.* **1994**, 243. (b) Prato, M.; Li, Q.; Wudl, F.; Lucchini, V. *J. Am. Chem. Soc.* **1993**, *115*, 1148.
- 6.15 The initial synthesis, isolation and characterization of an oxahomofullerene was of a fluorinated fullerene (C₆₀F₁₈O) in which the oxygen spans fluorinated carbons on a flattened, significantly π -depleted molecule: Boltalina, O. V.; de La Vaissiere; Fowler, P. W.; Hitchcock, P. B.; Sandall, J. P. B.; Troshin, P. A.; Taylor, R. *J. Chem. Soc., Chem. Commun.* **2000**, 1325.

APPENDIX A: ^1H NMR OF OLIGOPHENYLENES

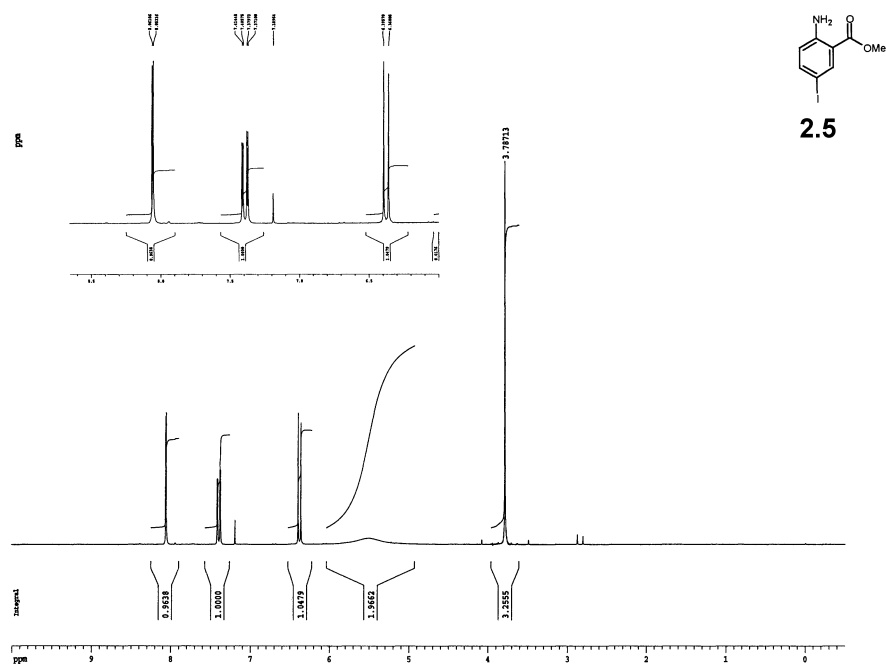

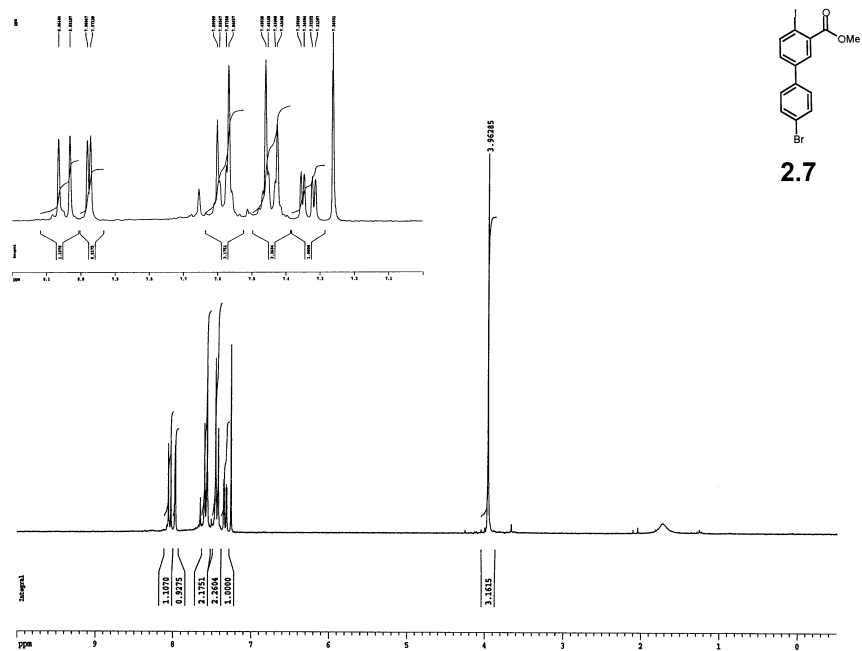

Figure A.3 ¹H NMR of Compound **2.7**

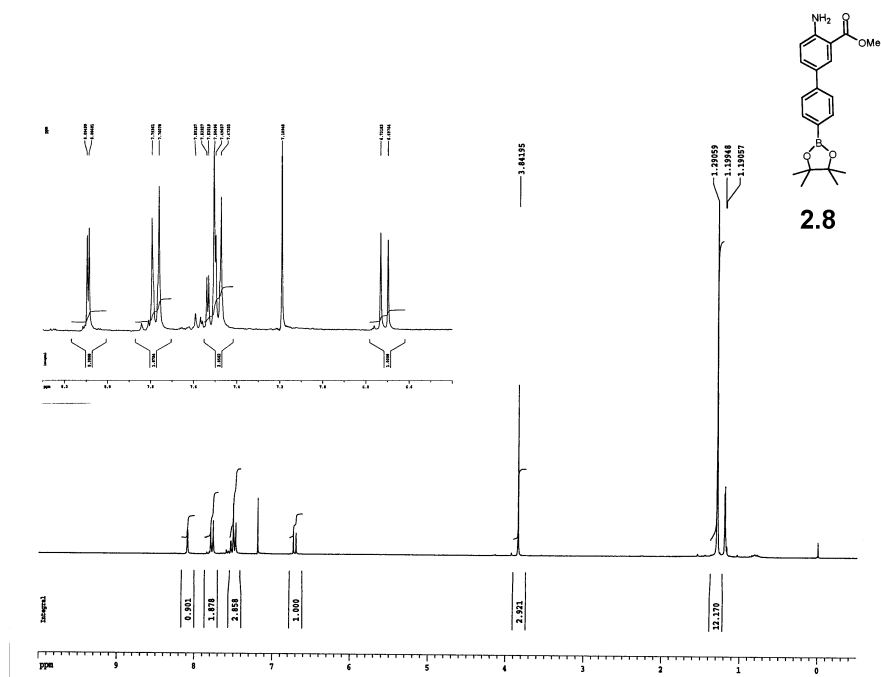

Figure A.4 ¹H NMR of Compound **2.8**

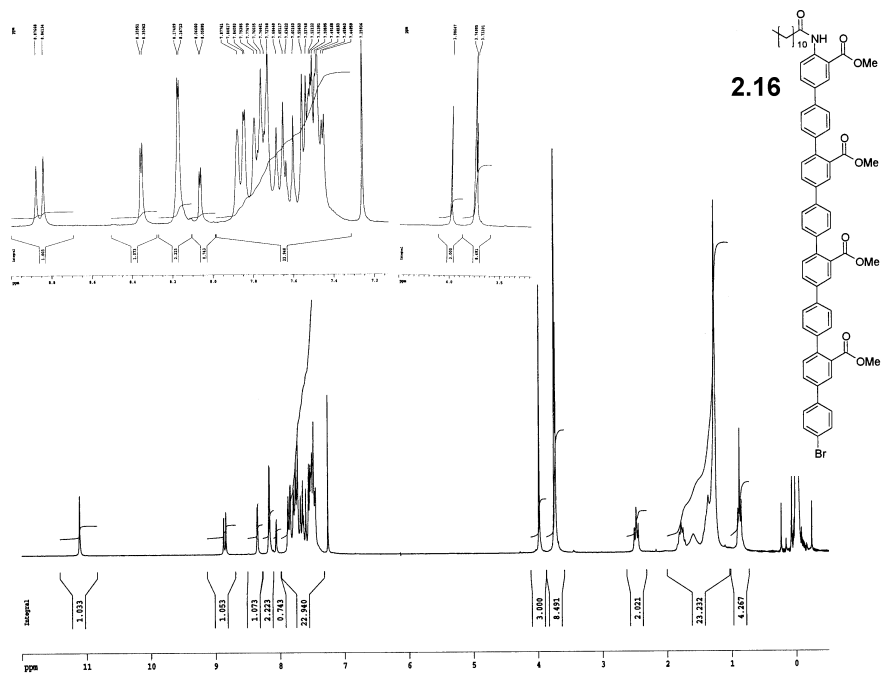

Figure A.9 ¹H NMR of Compound 2.16

APPENDIX B. CHARACTERIZATION DATA FOR COMPOUND 3.3b

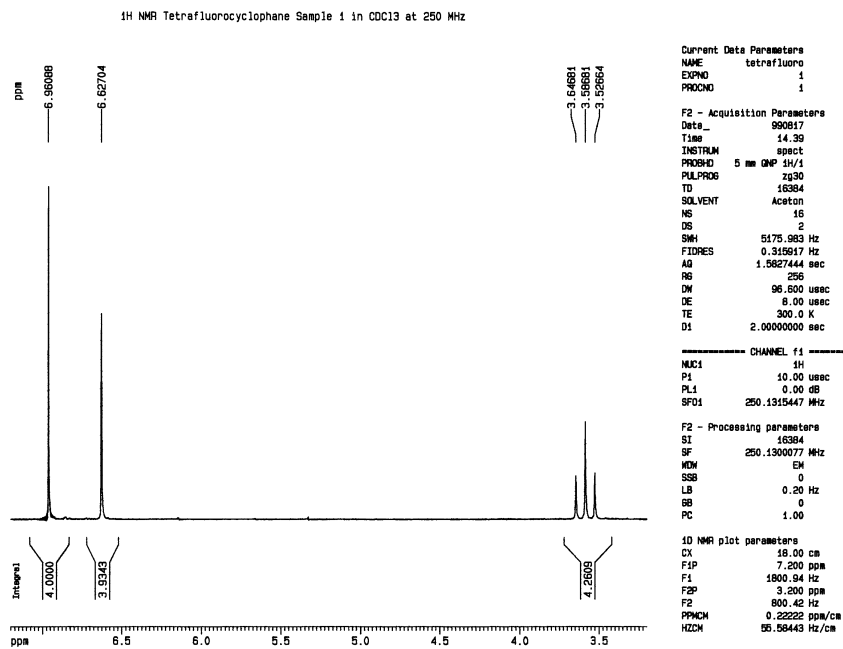

Figure B.1 ¹H NMR of Compound 3.3b

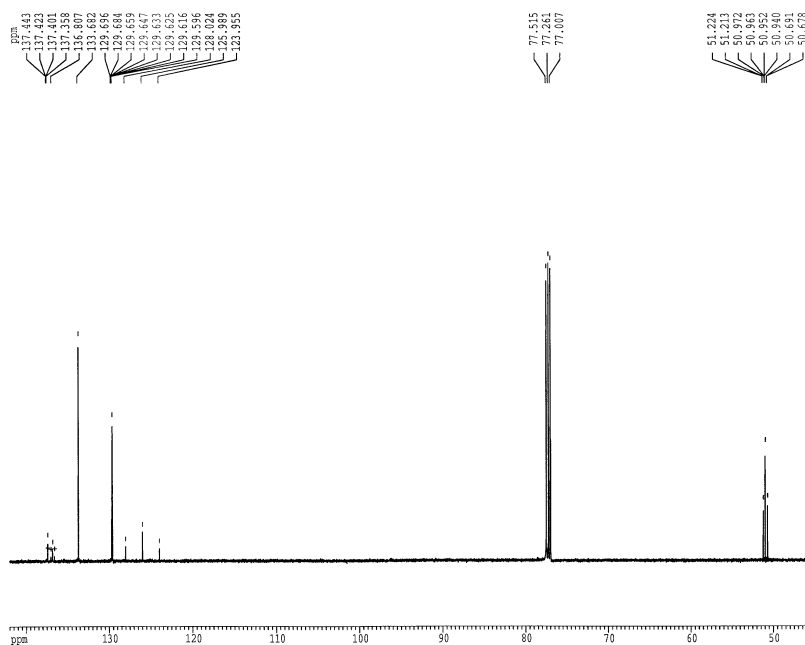

Figure B.2 ¹³C NMR of Compound 3.3b

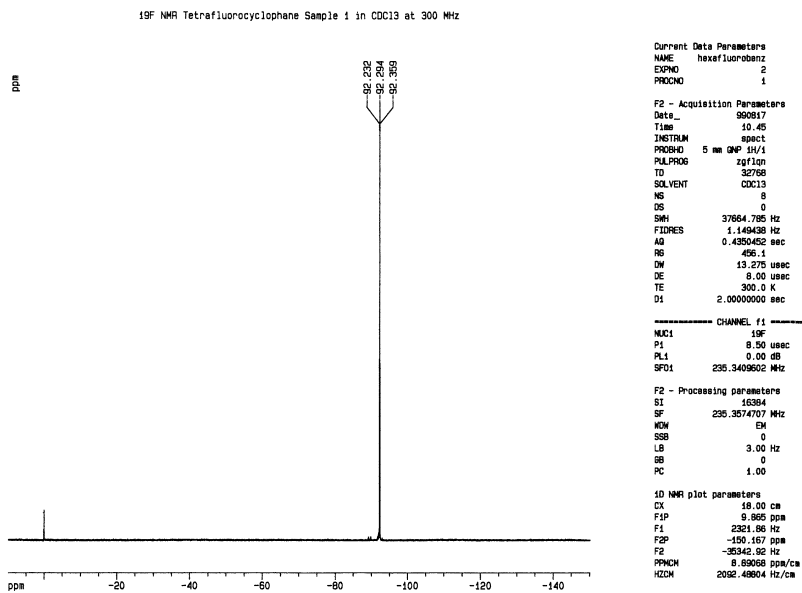

Figure B.3 ^{19}F NMR of Compound **3.3b**.

B.1 CRYSTALLOGRAPHIC DATA FOR COMPOUND 3.3a (CIF FORMAT)

data_3.3a

#####

5. CHEMICAL DATA

```

_chemical_name_systematic
;
;
1,1,9,9-Tetrafluoro-[2,2]-p-cyclophane
;
_chemical_name_common      ?
_chemical_formula_moiety   'C16 H12 F4'
_chemical_formula_structural ?
_chemical_formula_analytical ?
_chemical_formula_sum      'C16 H12 F4'
_chemical_formula_weight   280.27
_chemical_melting_point    ?
_chemical_compound_source  ?

```

```

loop_
  _atom_type_symbol
  _atom_type_description
  _atom_type_scatter_dispersion_real
  _atom_type_scatter_dispersion_imag
  _atom_type_scatter_source
C ? 0.017 0.009 International Tables Vol IV Table 2.3.1
H ? 0.000 0.000 International Tables Vol IV Table 2.3.1
F ? 0.069 0.053 International Tables Vol IV Table 2.3.1

```

```

#=====

```

6. CRYSTAL DATA

```

_symmetry_cell_setting      monoclinic
_symmetry_space_group_name_H-M  'C 1 2/c 1'
_symmetry_space_group_name_Hall  '-C 2yc'
loop_
  _symmetry_equiv_pos_as_xyz
  'x,y,z'
  -x,+y,1/2-z
  -x,-y,-z
  +x,-y,1/2+z
  1/2+x,1/2+y,+z
  1/2-x,1/2+y,1/2-z
  1/2-x,1/2-y,-z
  1/2+x,1/2-y,1/2+z
_cell_length_a              13.8709(5)
_cell_length_b              7.8354(5)
_cell_length_c              11.6450(9)
_cell_angle_alpha           90
_cell_angle_beta            99.898(4)
_cell_angle_gamma           90
_cell_volume                 1246.8(2)
_cell_formula_units_Z       4
_cell_measurement_temperature 296
_cell_measurement_reflns_used 25
_cell_measurement_theta_min 12.5
_cell_measurement_theta_max 43.2
_cell_special_details
;?
;

_exptl_crystal_description   fragment
_exptl_crystal_colour        'colorless'

```

```

_exptl_crystal_size_max      0.48
_exptl_crystal_size_mid     0.18
_exptl_crystal_size_min     0.15
_exptl_crystal_density_meas  ?
_exptl_crystal_density_diffn 1.492
_exptl_crystal_density_method 'none'
_exptl_crystal_F_000        576
_exptl_absorpt_coefficient_mu 1.079
_exptl_absorpt_correction_type psi_scans_(North,_Phillips,_Mathews,_1968)
_exptl_absorpt_correction_T_min 0.9677
_exptl_absorpt_correction_T_max 1.0000

```

#=====

7. EXPERIMENTAL DATA

```

_diffrn_special_details
;?
;

_diffrn_ambient_temperature 296
_diffrn_radiation_wavelength 1.54184
_diffrn_radiation_type      Cu-K\alpha
_diffrn_radiation_source    sealed_tube
_diffrn_radiation_monochromator graphite
_diffrn_measurement_device  Enraf_Nonius_CAD4
_diffrn_measurement_method  \q/2\q
_diffrn_standards_number    3
_diffrn_standards_interval_count ?
_diffrn_standards_interval_time 120
_diffrn_standards_decay_%   2.2

loop_
  _diffrn_standard_refl_index_h
  _diffrn_standard_refl_index_k
  _diffrn_standard_refl_index_l
-1 -3 4
 3 1 1
-3 1 2
_diffrn_reflns_number        3810
_diffrn_reflns_av_R_equivalents 0.017
_diffrn_reflns_limit_h_min   -17
_diffrn_reflns_limit_h_max    17
_diffrn_reflns_limit_k_min    -9
_diffrn_reflns_limit_k_max     8
_diffrn_reflns_limit_l_min   -14

```

```

_diffrn_reflms_limit_l_max      14
_diffrn_reflms_theta_min       2.5
_diffrn_reflms_theta_max       75.0
_reflms_number_total           1281
_reflms_number_observed         1215
_reflms_observed_criterion      >1.0\s(I)

_computing_data_collection      'CAD4_(Enraf-Nonius,_1994)'
_computing_cell_refinement      CAD4_(Enraf-Nonius,_1994)
_computing_data_reduction       'process_MoIEN_(Fair,_1990)'
_computing_structure_solution   Direct_methods_(SIR,_Burla_et_al.,_1989)
_computing_structure_refinement LSFM_MoIEN_(Fair,_1990)
_computing_molecular_graphics   ?
_computing_publication_material BTABLE_PTABLE_CIF_IN_MoIEN_(Fair,_1990)

```

#####

8. REFINEMENT DATA

```

_refine_ls_structure_factor_coef F
_refine_ls_matrix_type          full
_refine_ls_weighting_scheme     '4Fo^2^\s^2^(Fo^2^)+0.0004Fo^4^'
_refine_ls_hydrogen_treatment   calculated_U=1.3_x_bonding_atom
_refine_ls_extinction_method    isotropic_(Zachariasen,_1963)
_refine_ls_extinction_coef      1.8(2)E-5
_refine_ls_abs_structure_Flack   ?
_refine_ls_number_reflms        1215
_refine_ls_number_parameters     92
_refine_ls_number_restraints     0
_refine_ls_number_constraints    0
_refine_ls_abs_structure_details
; ?
;
_refine_ls_R_factor_all          0.053
_refine_ls_R_factor_obs          0.051
_refine_ls_wR_factor_all         0.080
_refine_ls_wR_factor_obs         0.080
_refine_ls_goodness_of_fit_all   4.461
_refine_ls_goodness_of_fit_obs   4.461
_refine_ls_shift/esd_max         0.000
_refine_ls_shift/esd_mean        0.000
_refine_diff_density_max         0.248
_refine_diff_density_min         -0.224

```

#####

9. ATOMIC COORDINATES AND THERMAL PARAMETERS

```
loop_
  _atom_site_label
  _atom_site_fract_x
  _atom_site_fract_y
  _atom_site_fract_z
  _atom_site_U_iso_or_equiv
  _atom_site_thermal_displace_type
  _atom_site_calc_flag
  _atom_site_calc_attached_atom
  _atom_site_type_symbol
F1 0.43775(9) 0.0129(2) 0.3573(1) 0.0975(8) Uij ?? F
F2 0.3710(1) 0.1940(2) 0.2291(1) 0.0924(8) Uij ?? F
C1 0.3780(1) 0.1523(3) 0.3435(1) 0.0601(8) Uij ?? C
C2 0.2207(1) 0.3941(2) 0.6285(1) 0.0490(7) Uij ?? C
C3 0.3015(1) 0.2951(2) 0.6730(1) 0.0526(8) Uij ?? C
C4 0.3795(1) 0.2844(2) 0.6136(2) 0.0564(8) Uij ?? C
C5 0.3765(1) 0.3680(2) 0.5079(1) 0.0561(8) Uij ?? C
C6 0.3056(1) 0.4929(2) 0.4788(2) 0.0581(8) Uij ?? C
C7 0.2276(1) 0.5052(2) 0.5376(2) 0.0546(8) Uij ?? C
C8 0.4320(1) 0.2986(3) 0.4168(2) 0.075(1) Uij ?? C
H3 0.3032 0.2348 0.7441 0.0699 Uiso calc C3 H
H4 0.4355 0.2192 0.6453 0.0751 Uiso calc C4 H
H6 0.3107 0.5708 0.4176 0.0763 Uiso calc C6 H
H7 0.1788 0.5898 0.5160 0.0722 Uiso calc C7 H
H8a 0.4421 0.3890 0.3658 0.0965 Uiso calc C8 H
H8b 0.4935 0.2571 0.4552 0.0965 Uiso calc C8 H
```

```
loop_
  _atom_site_aniso_label
  _atom_site_aniso_U_11
  _atom_site_aniso_U_22
  _atom_site_aniso_U_33
  _atom_site_aniso_U_12
  _atom_site_aniso_U_13
  _atom_site_aniso_U_23
  _atom_site_aniso_type_symbol
F1 0.0768(6) 0.0863(8) 0.140(1) 0.0258(6) 0.0405(6) -0.0123(7) F
F2 0.0933(7) 0.151(1) 0.0560(5) -0.0147(9) 0.0292(5) -0.0003(7) F
C1 0.0601(8) 0.067(1) 0.0535(7) 0.0080(8) 0.0202(6) -0.0082(7) C
C2 0.0556(7) 0.0466(7) 0.0453(6) 0.0027(7) 0.0106(5) -0.0098(6) C
C3 0.0603(8) 0.0562(9) 0.0429(7) 0.0045(7) 0.0036(6) -0.0042(6) C
C4 0.0488(7) 0.0636(9) 0.0580(8) 0.0052(7) 0.0006(7) -0.0105(7) C
```

C5 0.0493(7) 0.0584(8) 0.0612(8) -0.0126(7) 0.0148(6) -0.0145(7) C
C6 0.0748(9) 0.0468(8) 0.0560(8) -0.0090(7) 0.0156(7) -0.0008(7) C
C7 0.0666(8) 0.0433(8) 0.0563(8) 0.0079(7) 0.0096(7) -0.0038(6) C
C8 0.0604(8) 0.088(1) 0.081(1) -0.0140(9) 0.0307(7) -0.021(1) C

10. MOLECULAR GEOMETRY

loop_

_geom_bond_atom_site_label_1
_geom_bond_atom_site_label_2
_geom_bond_distance
_geom_bond_site_symmetry_1
_geom_bond_site_symmetry_2
_geom_bond_publ_flag
F1 C1 1.363(2) .. ?
F2 C1 1.359(2) .. ?
C1 C2 1.506(2) .7_556 ?
C1 C8 1.545(3) .. ?
C2 C3 1.387(2) .. ?
C2 C7 1.386(2) .. ?
C3 C4 1.384(3) .. ?
C3 H3 0.950 .. ?
C4 C5 1.389(3) .. ?
C4 H4 0.950 .. ?
C5 C6 1.388(2) .. ?
C5 C8 1.514(3) .. ?
C6 C7 1.379(3) .. ?
C6 H6 0.950 .. ?
C7 H7 0.950 .. ?
C8 H8a 0.950 .. ?
C8 H8b 0.950 .. ?

loop_

_geom_contact_atom_site_label_1
_geom_contact_atom_site_label_2
_geom_contact_distance
_geom_contact_site_symmetry_1
_geom_contact_site_symmetry_2
_geom_contact_publ_flag
? ? ? ? ? ?

loop_

_geom_angle_atom_site_label_1
_geom_angle_atom_site_label_2

_geom_angle_atom_site_label_3
 _geom_angle
 _geom_angle_site_symmetry_1
 _geom_angle_site_symmetry_2
 _geom_angle_site_symmetry_3
 _geom_angle_publ_flag
 F1 C1 F2 104.3(2) . . . ?
 F1 C1 C2 109.8(2) . . 7_556 ?
 F1 C1 C8 107.6(1) . . . ?
 F2 C1 C2 110.8(1) . . 7_556 ?
 F2 C1 C8 108.0(2) . . . ?
 C2 C1 C8 115.6(2) . 7_556 . ?
 C1 C2 C3 119.4(1) . 7_556 . ?
 C1 C2 C7 120.1(1) . 7_556 . ?
 C3 C2 C7 118.6(2) . . . ?
 C2 C3 C4 119.9(2) . . . ?
 C2 C3 H3 120.1 . . . ?
 C4 C3 H3 120.1 . . . ?
 C3 C4 C5 120.5(2) . . . ?
 C3 C4 H4 119.7 . . . ?
 C5 C4 H4 119.7 . . . ?
 C4 C5 C6 117.4(2) . . . ?
 C4 C5 C8 120.6(2) . . . ?
 C6 C5 C8 120.5(2) . . . ?
 C5 C6 C7 120.8(2) . . . ?
 C5 C6 H6 119.6 . . . ?
 C7 C6 H6 119.6 . . . ?
 C2 C7 C6 119.9(2) . . . ?
 C2 C7 H7 120.1(2) . . . ?
 C6 C7 H7 120.1(2) . . . ?
 C1 C8 C5 113.4(2) . . . ?
 C1 C8 H8a 108.5 . . . ?
 C1 C8 H8b 108.5 . . . ?
 C5 C8 H8a 108.5 . . . ?
 C5 C8 H8b 108.5 . . . ?
 H8a C8 H8b 109.5 . . . ?

loop_
 _geom_torsion_atom_site_label_1
 _geom_torsion_atom_site_label_2
 _geom_torsion_atom_site_label_3
 _geom_torsion_atom_site_label_4
 _geom_torsion
 _geom_torsion_site_symmetry_1
 _geom_torsion_site_symmetry_2
 _geom_torsion_site_symmetry_3

```

    _geom_torsion_site_symmetry_4
    _geom_torsion_publ_flag
F1 C1 C8 C5 -121.5(2) . . . . ?
F2 C1 C8 C5 126.4(2) . . . . ?
C7 C2 C3 C4 -12.1(2) . . . . ?
C3 C2 C7 C6 12.4(2) . . . . ?
C2 C3 C4 C5 -1.9(3) . . . . ?
C3 C4 C5 C6 15.2(3) . . . . ?
C3 C4 C5 C8 -151.1(2) . . . . ?
C4 C5 C6 C7 -15.0(3) . . . . ?
C8 C5 C6 C7 151.4(2) . . . . ?
C4 C5 C8 C1 80.9(2) . . . . ?
C6 C5 C8 C1 -85.0(2) . . . . ?
C5 C6 C7 C2 1.3(3) . . . . ?
# END OF CIF

```

B.2 CRYSTALLOGRAPHIC DATA FOR COMPOUND 3.3b (CIF FORMAT)

data_3.3b

#=====

5. CHEMICAL DATA

```

    _chemical_name_systematic
;
1,1,10,10-Tetrafluoro-[2,2]-p-cyclophane
;
    _chemical_name_common          ?
    _chemical_formula_moiety       'C16 H12 F4'
    _chemical_formula_structural   ?
    _chemical_formula_analytical   ?
    _chemical_formula_sum          'C16 H12 F4'
    _chemical_formula_weight       280.27
    _chemical_melting_point        533-534
    _chemical_compound_source      ?

```

```

loop_
    _atom_type_symbol
    _atom_type_description
    _atom_type_scatter_dispersion_real
    _atom_type_scatter_dispersion_imag
    _atom_type_scatter_source
C ? 0.017 0.009 International_Tables_Vol_IV_Table_2.3.1
H ? 0.000 0.000 International_Tables_Vol_IV_Table_2.3.1

```

#=====

6. CRYSTAL DATA

```

_symmetry_cell_setting      monoclinic
_symmetry_space_group_name_H-M  'C 1 2/c 1'
_symmetry_space_group_name_Hall  '-C 2yc'
loop_
  _symmetry_equiv_pos_as_xyz
    'x,y,z'
    -x,+y,1/2-z
    -x,-y,-z
    +x,-y,1/2+z
    1/2+x,1/2+y,+z
    1/2-x,1/2+y,1/2-z
    1/2-x,1/2-y,-z
    1/2+x,1/2-y,1/2+z
  _cell_length_a            27.656(2)
  _cell_length_b            8.1496(9)
  _cell_length_c            11.364(1)
  _cell_angle_alpha         90
  _cell_angle_beta          102.841(8)
  _cell_angle_gamma         90
  _cell_volume               2497.3(8)
  _cell_formula_units_z     8
  _cell_measurement_temperature  297
  _cell_measurement_reflns_used  25
  _cell_measurement_theta_min  21.7
  _cell_measurement_theta_max  44.8
  _cell_special_details
;?
;

  _exptl_crystal_description  prism
  _exptl_crystal_colour       'colorless'
  _exptl_crystal_size_max     0.45
  _exptl_crystal_size_mid     0.27
  _exptl_crystal_size_min     0.25
  _exptl_crystal_density_meas  ?
  _exptl_crystal_density_diffn  1.490
  _exptl_crystal_density_method  'none'
  _exptl_crystal_F_000        1152

```

_exptl_absorpt_coefficient_mu 1.078
_exptl_absorpt_correction_type psi_scans_(North,_Phillips,_Mathews,_1968)
_exptl_absorpt_correction_T_min 0.8477
_exptl_absorpt_correction_T_max 1.0000

#####

7. EXPERIMENTAL DATA

_diffn_special_details

;

;

_diffn_ambient_temperature 297
_diffn_radiation_wavelength 1.54184
_diffn_radiation_type Cu-K α
_diffn_radiation_source sealed_tube
_diffn_radiation_monochromator graphite
_diffn_measurement_device Enraf_Nonius_CAD4
_diffn_measurement_method $\lambda/2\lambda$
_diffn_standards_number 3
_diffn_standards_interval_count ?
_diffn_standards_interval_time 120
_diffn_standards_decay_% 9.4

loop_

_diffn_standard_refl_index_h
_diffn_standard_refl_index_k
_diffn_standard_refl_index_l
6 -4 -1
-8 -2 4
-8 -2 -8
_diffn_reflns_number 2906
_diffn_reflns_av_R_equivalents 0.020
_diffn_reflns_limit_h_min -33
_diffn_reflns_limit_h_max 34
_diffn_reflns_limit_k_min -10
_diffn_reflns_limit_k_max 0
_diffn_reflns_limit_l_min -14
_diffn_reflns_limit_l_max 0
_diffn_reflns_theta_min 2.5
_diffn_reflns_theta_max 75.0
_reflns_number_total 2576
_reflns_number_observed 2290
_reflns_observed_criterion $>1.0\sigma(I)$
_computing_data_collection 'CAD4_(Enraf-Nonius,_1994)'

```

_computing_cell_refinement      CAD4_(Enraf-Nonius,_1994)
_computing_data_reduction      'process_MoIEN_(Fair,_1990)'
_computing_structure_solution  Direct_methods_(SIR,_Burla_et_al.,_1989)
_computing_structure_refinement LSFM_MoIEN_(Fair,_1990)
_computing_molecular_graphics  ?
_computing_publication_material BTABLE_PTABLE_CIF_IN_MoIEN_(Fair,_1990)

```

```

#=====

```

8. REFINEMENT DATA

```

_refine_ls_structure_factor_coef F
_refine_ls_matrix_type          full
_refine_ls_weighting_scheme     '4Fo^2^/(\s^2^(Fo^2^) + 0.0004 Fo^4^)'
_refine_ls_hydrogen_treatment   calculated_U=1.3_x_bonding_atom
_refine_ls_extinction_method    isotropic_(Zachariasen,_1963)
_refine_ls_extinction_coef      4.5(4)E-6
_refine_ls_abs_structure_Flack  ?
_refine_ls_number_reflns       2290
_refine_ls_number_parameters    182
_refine_ls_number_restraints    0
_refine_ls_number_constraints    0
_refine_ls_abs_structure_details
;?
;
_refine_ls_R_factor_all         0.063
_refine_ls_R_factor_obs         0.058
_refine_ls_wR_factor_all        0.077
_refine_ls_wR_factor_obs        0.077
_refine_ls_goodness_of_fit_all  4.304
_refine_ls_goodness_of_fit_obs  4.308
_refine_ls_shift/esd_max        0.005
_refine_ls_shift/esd_mean       0.001
_refine_diff_density_max        0.184
_refine_diff_density_min        -0.242

```

```

#=====

```

9. ATOMIC COORDINATES AND THERMAL PARAMETERS

```

loop_
_atom_site_label
_atom_site_fract_x
_atom_site_fract_y
_atom_site_fract_z

```

_atom_site_U_iso_or_equiv
 _atom_site_thermal_displace_type
 _atom_site_calc_flag
 _atom_site_calc_attached_atom
 _atom_site_type_symbol
 F1 0.47055(5) 0.0352(2) 0.6113(1) 0.0879(8) Uij ?? F
 F2 0.43495(5) 0.2033(2) 0.7122(1) 0.0836(8) Uij ?? F
 F3 0.27527(6) 0.0747(2) 0.1162(1) 0.0955(9) Uij ?? F
 F4 0.24033(5) 0.2599(2) 0.2020(1) 0.0976(9) Uij ?? F
 C1 0.43930(7) 0.1668(3) 0.5976(2) 0.059(1) Uij ?? C
 C2 0.38979(6) 0.1209(2) 0.5203(1) 0.0508(8) Uij ?? C
 C3 0.34862(7) 0.2170(2) 0.5222(2) 0.0576(9) Uij ?? C
 C4 0.30976(6) 0.2255(2) 0.4223(2) 0.0586(9) Uij ?? C
 C5 0.31225(6) 0.1372(2) 0.3189(2) 0.0540(9) Uij ?? C
 C6 0.34810(7) 0.0176(2) 0.3266(2) 0.0568(9) Uij ?? C
 C7 0.38708(7) 0.0088(2) 0.4265(2) 0.0552(9) Uij ?? C
 C8 0.28563(7) 0.2014(3) 0.1972(2) 0.066(1) Uij ?? C
 C9 0.3133(1) 0.3353(4) 0.1431(2) 0.097(2) Uij ?? C
 C10 0.36228(8) 0.3833(3) 0.2230(2) 0.063(1) Uij ?? C
 C11 0.36470(8) 0.4975(3) 0.3142(2) 0.070(1) Uij ?? C
 C12 0.40287(8) 0.4920(2) 0.4156(2) 0.067(1) Uij ?? C
 C13 0.43897(7) 0.3719(2) 0.4279(2) 0.062(1) Uij ?? C
 C14 0.44237(7) 0.2852(3) 0.3259(2) 0.069(1) Uij ?? C
 C15 0.40431(8) 0.2915(3) 0.2246(2) 0.069(1) Uij ?? C
 C16 0.46569(9) 0.3110(3) 0.5512(2) 0.089(1) Uij ?? C
 H3 0.3471 0.2776 0.5927 0.0746 Uiso calc C3 H
 H4 0.2815 0.2910 0.4240 0.0759 Uiso calc C4 H
 H6 0.3460 -0.0593 0.2628 0.0761 Uiso calc C6 H
 H7 0.4118 -0.0732 0.4312 0.0731 Uiso calc C7 H
 H9a 0.2928 0.4300 0.1286 0.1382 Uiso calc C9 H
 H9b 0.3192 0.2960 0.0688 0.1382 Uiso calc C9 H
 H11 0.3400 0.5801 0.3069 0.0900 Uiso calc C11 H
 H12 0.4044 0.5714 0.4775 0.0888 Uiso calc C12 H
 H14 0.4710 0.2211 0.3255 0.0882 Uiso calc C14 H
 H15 0.4071 0.2315 0.1547 0.0902 Uiso calc C15 H
 H16a 0.4980 0.2765 0.5465 0.1248 Uiso calc C16 H
 H16b 0.4681 0.3991 0.6070 0.1248 Uiso calc C16 H

loop_
 _atom_site_aniso_label
 _atom_site_aniso_U_11
 _atom_site_aniso_U_22
 _atom_site_aniso_U_33
 _atom_site_aniso_U_12
 _atom_site_aniso_U_13

_atom_site_aniso_U_23

_atom_site_aniso_type_symbol

| | | | | | | | |
|-----|-----------|-----------|-----------|------------|------------|------------|---|
| F1 | 0.0770(7) | 0.0908(8) | 0.0971(9) | 0.0208(7) | -0.0179(6) | 0.0012(8) | F |
| F2 | 0.0965(9) | 0.132(1) | 0.0457(5) | -0.0088(8) | -0.0005(6) | -0.0134(7) | F |
| F3 | 0.127(1) | 0.0974(9) | 0.0706(7) | 0.0015(9) | -0.0277(7) | -0.0164(7) | F |
| F4 | 0.0676(7) | 0.128(1) | 0.107(1) | 0.0244(8) | -0.0078(7) | 0.0129(9) | F |
| C1 | 0.066(1) | 0.070(1) | 0.0431(8) | 0.0007(9) | -0.0010(7) | 0.0056(8) | C |
| C2 | 0.0586(8) | 0.0553(9) | 0.0406(7) | -0.0029(8) | 0.0056(6) | 0.0070(7) | C |
| C3 | 0.0648(9) | 0.064(1) | 0.0462(7) | -0.0024(9) | 0.0183(6) | 0.0012(8) | C |
| C4 | 0.0508(8) | 0.065(1) | 0.0612(9) | 0.0009(8) | 0.0158(7) | 0.0055(8) | C |
| C5 | 0.0484(8) | 0.059(1) | 0.0554(9) | -0.0074(8) | 0.0023(7) | 0.0020(8) | C |
| C6 | 0.065(1) | 0.0534(9) | 0.0526(9) | -0.0047(8) | 0.0037(8) | -0.0053(8) | C |
| C7 | 0.0619(9) | 0.0507(9) | 0.0536(8) | 0.0030(8) | 0.0073(7) | 0.0042(7) | C |
| C8 | 0.059(1) | 0.077(1) | 0.063(1) | -0.001(1) | -0.0117(9) | -0.002(1) | C |
| C9 | 0.097(2) | 0.130(2) | 0.072(1) | -0.028(1) | -0.024(1) | 0.041(1) | C |
| C10 | 0.073(1) | 0.070(1) | 0.0506(8) | -0.008(1) | 0.0026(8) | 0.0186(8) | C |
| C11 | 0.072(1) | 0.061(1) | 0.077(1) | 0.0070(9) | 0.0212(8) | 0.0205(9) | C |
| C12 | 0.087(1) | 0.058(1) | 0.061(1) | -0.014(1) | 0.0189(9) | -0.0019(9) | C |
| C13 | 0.0564(9) | 0.070(1) | 0.0596(9) | -0.0179(9) | 0.0034(7) | 0.0096(9) | C |
| C14 | 0.0598(9) | 0.073(1) | 0.076(1) | 0.0028(9) | 0.0259(8) | 0.0156(9) | C |
| C15 | 0.092(1) | 0.070(1) | 0.0512(8) | -0.005(1) | 0.0263(8) | 0.0053(8) | C |
| C16 | 0.079(1) | 0.113(2) | 0.078(1) | -0.036(1) | -0.020(1) | 0.026(1) | C |

10. MOLECULAR GEOMETRY

loop_

_geom_bond_atom_site_label_1

_geom_bond_atom_site_label_2

_geom_bond_distance

_geom_bond_site_symmetry_1

_geom_bond_site_symmetry_2

_geom_bond_publ_flag

F1 C1 1.365(2) .. ?

F2 C1 1.368(2) .. ?

F3 C8 1.370(3) .. ?

F4 C8 1.353(3) .. ?

C1 C2 1.501(2) .. ?

C1 C16 1.537(3) .. ?

C2 C3 1.386(3) .. ?

C2 C7 1.393(2) .. ?

C3 C4 1.381(2) .. ?

C3 H3 0.950 .. ?

C4 C5 1.392(3) .. ?

C4 H4 0.950 .. ?

C5 C6 1.379(3) .. ?
C5 C8 1.509(3) .. ?
C6 C7 1.383(2) .. ?
C6 H6 0.950 .. ?
C7 H7 0.950 .. ?
C8 C9 1.538(4) .. ?
C9 C10 1.505(3) .. ?
C9 H9a 0.950 .. ?
C9 H9b 0.950 .. ?
C10 C11 1.383(3) .. ?
C10 C15 1.379(3) .. ?
C11 C12 1.380(3) .. ?
C11 H11 0.950 .. ?
C12 C13 1.383(3) .. ?
C12 H12 0.950 .. ?
C13 C14 1.379(3) .. ?
C13 C16 1.515(3) .. ?
C14 C15 1.377(3) .. ?
C14 H14 0.950 .. ?
C15 H15 0.950 .. ?
C16 H16a 0.950 .. ?
C16 H16b 0.950 .. ?

loop_
 _geom_contact_atom_site_label_1
 _geom_contact_atom_site_label_2
 _geom_contact_distance
 _geom_contact_site_symmetry_1
 _geom_contact_site_symmetry_2
 _geom_contact_publ_flag
 ? ? ? ? ? ?

loop_
 _geom_angle_atom_site_label_1
 _geom_angle_atom_site_label_2
 _geom_angle_atom_site_label_3
 _geom_angle
 _geom_angle_site_symmetry_1
 _geom_angle_site_symmetry_2
 _geom_angle_site_symmetry_3
 _geom_angle_publ_flag
F1 C1 F2 104.4(1) . . . ?
F1 C1 C2 110.1(2) . . . ?
F1 C1 C16 107.7(2) . . . ?
F2 C1 C2 110.5(2) . . . ?
F2 C1 C16 108.0(2) . . . ?

C2 C1 C16 115.5(2) . . . ?
 C1 C2 C3 119.7(2) . . . ?
 C1 C2 C7 119.9(2) . . . ?
 C3 C2 C7 118.5(1) . . . ?
 C2 C3 C4 120.5(2) . . . ?
 C2 C3 H3 119.8 . . . ?
 C4 C3 H3 119.8 . . . ?
 C3 C4 C5 119.5(2) . . . ?
 C3 C4 H4 120.2 . . . ?
 C5 C4 H4 120.2 . . . ?
 C4 C5 C6 118.8(1) . . . ?
 C4 C5 C8 119.2(2) . . . ?
 C6 C5 C8 120.0(2) . . . ?
 C5 C6 C7 120.4(2) . . . ?
 C5 C6 H6 119.8 . . . ?
 C7 C6 H6 119.8 . . . ?
 C2 C7 C6 119.6(2) . . . ?
 C2 C7 H7 120.2 . . . ?
 C6 C7 H7 120.2 . . . ?
 F3 C8 F4 103.6(2) . . . ?
 F3 C8 C5 109.9(2) . . . ?
 F3 C8 C9 108.3(2) . . . ?
 F4 C8 C5 110.7(2) . . . ?
 F4 C8 C9 108.3(2) . . . ?
 C5 C8 C9 115.3(2) . . . ?
 C8 C9 C10 113.9(2) . . . ?
 C8 C9 H9a 108.4 . . . ?
 C8 C9 H9b 108.4 . . . ?
 C10 C9 H9a 108.4 . . . ?
 C10 C9 H9b 108.4 . . . ?
 H9a C9 H9b 109.5 . . . ?
 C9 C10 C11 120.9(2) . . . ?
 C9 C10 C15 120.7(2) . . . ?
 C11 C10 C15 117.1(2) . . . ?
 C10 C11 C12 120.3(2) . . . ?
 C10 C11 H11 119.8 . . . ?
 C12 C11 H11 119.8 . . . ?
 C11 C12 C13 120.6(2) . . . ?
 C11 C12 H12 119.7 . . . ?
 C13 C12 H12 119.7 . . . ?
 C12 C13 C14 117.4(2) . . . ?
 C12 C13 C16 121.2(2) . . . ?
 C14 C13 C16 120.0(2) . . . ?
 C13 C14 C15 120.1(2) . . . ?
 C13 C14 H14 119.9 . . . ?
 C15 C14 H14 119.9 . . . ?

C10 C15 C14 121.1(2) . . . ?
C10 C15 H15 119.5 . . . ?
C14 C15 H15 119.5 . . . ?
C1 C16 C13 113.3(2) . . . ?
C1 C16 H16a 108.5 . . . ?
C1 C16 H16b 108.5 . . . ?
C13 C16 H16a 108.5 . . . ?
C13 C16 H16b 108.5 . . . ?
H16a C16 H16b 109.5 . . . ?

loop_

 _geom_torsion_atom_site_label_1
 _geom_torsion_atom_site_label_2
 _geom_torsion_atom_site_label_3
 _geom_torsion_atom_site_label_4
 _geom_torsion
 _geom_torsion_site_symmetry_1
 _geom_torsion_site_symmetry_2
 _geom_torsion_site_symmetry_3
 _geom_torsion_site_symmetry_4
 _geom_torsion_publ_flag
F1 C1 C2 C3 161.5(2) ?
F1 C1 C2 C7 -34.1(2) ?
F2 C1 C2 C3 46.7(2) ?
F2 C1 C2 C7 -149.0(2) ?
C16 C1 C2 C3 -76.3(2) ?
C16 C1 C2 C7 88.1(2) ?
F1 C1 C16 C13 117.9(2) ?
F2 C1 C16 C13 -129.8(2) ?
C2 C1 C16 C13 -5.5(3) ?
C1 C2 C3 C4 151.8(2) ?
C7 C2 C3 C4 -12.7(3) ?
C1 C2 C7 C6 -151.9(2) ?
C3 C2 C7 C6 12.6(3) ?
C2 C3 C4 C5 -0.3(3) ?
C3 C4 C5 C6 13.5(3) ?
C3 C4 C5 C8 -150.7(2) ?
C4 C5 C6 C7 -13.6(3) ?
C8 C5 C6 C7 150.5(2) ?
C4 C5 C8 F3 -155.7(2) ?
C4 C5 C8 F4 -41.8(2) ?
C4 C5 C8 C9 81.6(2) ?
C6 C5 C8 F3 40.3(2) ?
C6 C5 C8 F4 154.2(2) ?
C6 C5 C8 C9 -82.5(2) ?
C5 C6 C7 C2 0.5(3) ?

F3 C8 C9 C10 -125.1(2) ?
F4 C8 C9 C10 123.1(2) ?
C5 C8 C9 C10 -1.5(3) ?
C8 C9 C10 C11 -83.8(3) ?
C8 C9 C10 C15 82.5(3) ?
C9 C10 C11 C12 152.2(2) ?
C15 C10 C11 C12 -14.6(3) ?
C9 C10 C15 C14 -151.8(2) ?
C11 C10 C15 C14 15.0(3) ?
C10 C11 C12 C13 -0.4(3) ?
C11 C12 C13 C14 15.3(3) ?
C11 C12 C13 C16 -151.2(2) ?
C12 C13 C14 C15 -14.9(3) ?
C16 C13 C14 C15 151.7(2) ?
C12 C13 C16 C1 88.8(3) ?
C14 C13 C16 C1 -77.3(3) ?
C13 C14 C15 C10 -0.2(3) ?
END OF CIF

APPENDIX C. LETTERS OF PERMISSION

09/23/2002 13:18 FAX 2027768112

002/002

SEP-20-2002 16:15 FROM LSU Chemistry 225 5783458 TO 9120277681123292600 P.01



LOUISIANA STATE UNIVERSITY
AND AGRICULTURAL MECHANICAL COLLEGE
AGS. PUBLICATIONS DIVISION
Department of Chemistry

SEP 23 2002

COPYRIGHT OFFICE

September 20, 2002

American Chemical Society
Copyright Office, Publications Division
1155 16th St., N. W.
Washington, DC 20036

To Whom It May Concern:

I am writing to obtain permission for the use of my contributions to three articles published in "The Journal of the American Chemical Society" and "Organic Letters." I am a graduate student in the Department of Chemistry at Louisiana State University. I am one of the authors on the articles and I would like to include my contributions to the articles in my doctoral dissertation. The articles are:

- "Convenient Iterative Synthesis of an Octameric Carboxylate-Functionalized Oligophenylene Rod with Divergent Endgroups," *Org. Lett.*, 2000, 2(20), 3201-3204.
- "An Unusual Seven Bond H-H Spin Coupling," *Org. Lett.*; 2000, 2(24), 3813-3815.
- "The Mechanism of Chromophore Formation in Resorcinarene Solutions and Visual Detection of Mono- and Oligosaccharides" *J. Am. Chem. Soc.*, 2002, 124(18), 5000-5009.

Thank you for your consideration of this request.

Sincerely,

Jorge O. Escobedo
Phone: (225)-578-3573
Fax: (225)-578-3458
E-mail: jescob1@lsu.edu



American Chemical Society

Publications Division
Copyright Office

1155 Sixteenth Street, NW
Washington DC 20036
Phone: (1) 202-872-4368 or -4367
Fax: (1) 202-776-8112 E-mail: copyright@acs.org

FAX NUMBER: 225-578-3458

DATE: September 23, 2002

MEMORANDUM

TO: Jorge O. Escobedo, Department of Chemistry, Louisiana State University
Baton Rouge, LA 10803-1804

FROM: C. Arleen Courtney, Copyright Associate *C Arleen Courtney*

Thank you for your recent request for permission to include your paper(s) or portions of your paper(s) in your thesis. Permission is now automatically granted; please pay special attention to the implications paragraph below. The Joint Board/Council Committees on Copyrights and Publications recently approved the following:

Copyright permission for published and submitted material from theses and dissertations

ACS extends blanket permission to students to include in their theses and dissertations their own articles, or portions thereof, that have been published in ACS journals or submitted to ACS journals for publication, provided that the ACS copyright credit line is noted on the appropriate page(s).

Publishing implications of electronic publication of theses and dissertation material

Students and their mentors should be aware that posting of theses and dissertation material on the Web prior to submission of material from that thesis or dissertation to an ACS journal may affect publication in that journal. Whether Web posting is considered prior publication may be evaluated on a case-by-case basis by the journal's editor. If an ACS journal editor considers Web posting to be "prior publication", the paper will not be accepted for publication in that journal.

If your paper has not yet been published by ACS, we have no objection to your including part or all of it in your thesis in print and microfilm formats; please note, however, that electronic distribution or Web posting of the unpublished paper as part of your thesis in electronic formats might jeopardize publication of your paper by ACS. Please print the following credit line on the first page of your article: "Reproduced (or 'Reproduced in part') with permission from [JOURNAL NAME], in press (or 'submitted for publication'). Unpublished work copyright [CURRENT YEAR] American Chemical Society." Include appropriate information.

If your paper has already been published by ACS and you want to include part or all of it in your thesis or dissertation, please print the ACS copyright credit line on the first page of your article: "Reproduced (or 'Reproduced in part') with permission from [FULL REFERENCE CITATION.] Copyright [YEAR] American Chemical Society." Include appropriate information.

Note: If you plan to submit your thesis to UMI or to another dissertation distributor, you should not include the unpublished ACS paper in your thesis if the thesis will be disseminated electronically, until ACS has published your paper. After publication of the paper by ACS, you may release the entire thesis (**not the individual ACS article by itself**) for electronic dissemination; ACS's copyright credit line should be printed on the first page of the ACS paper. **Permission is not granted to post any published or unpublished ACS articles on any Web site, including electronic archives.**

Thank you for writing. Questions? Please call me at 202/872-4368 or send e-mail to copyright@acs.org.

4/11/02



ELSEVIER
SCIENCE

10 October 2002

Our ref: HW/smc/October 2002.178

Dr Jorge Escobedo
Louisiana State University
Department of Chemistry
Baton Rouge, LA 70803-1804
USA

Dear Dr Escobedo

TETRAHEDRON LETTERS, Vol 42, No 21, 2001, Page 3555, "Convenient synthesis and ..."; Vol 43, No 35, 2002, Page 6117, "Investigation of the ..."

As per your letter dated 20 September 2002, we hereby grant you permission to reprint the aforementioned material at no charge in your thesis subject to the following conditions:

1. If any part of the material to be used (for example, figures) has appeared in our publication with credit or acknowledgement to another source, permission must also be sought from that source. If such permission is not obtained then that material may not be included in your publication/copies.
2. Suitable acknowledgment to the source must be made, either as a footnote or in a reference list at the end of your publication, as follows:

"Reprinted from Publication title, Vol number, Author(s), Title of article, Pages No., Copyright (Year), with permission from Elsevier Science".
3. Reproduction of this material is confined to the purpose for which permission is hereby given.
4. This permission is granted for non-exclusive world **English** rights only. For other languages please reapply separately for each one required. Permission excludes use in an electronic form. Should you have a specific electronic project in mind please reapply for permission.
5. This includes permission for UMI to supply single copies, on demand, of the complete thesis. Should your thesis be published commercially, please reapply for permission.

Yours sincerely

Helen Wilson
Rights Manager

Your future requests will be handled more quickly if you complete the online form at www.elsevier.com

Elsevier Science, Global Rights Department, PO Box 800, Oxford OX5 1DX, UK
Tel +44 (0)1865 843830 | Fax +44 (0)1865 853333 | www.elsevier.com
vat no. 494 6272 12

*Academic Press • Butterworth-Heinemann • Cell Press • Churchill Livingstone • Engineering Information • Excerpta Medica
The Lancet • MDConsult • MDL • Mosby • North-Holland • Pergamon • ScienceDirect • WB Saunders*

VITA

Jorge Omar Escobedo Córdova was born in Monterrey, Nuevo León, México on April 17, 1962. He graduated in 1984 at the Facultad de Ciencias Químicas, Universidad Autónoma de Nuevo León. In 1994 He obtained the degree of Master of Science in chemistry at the same institution. In 1997 he was awarded with a Fullbright Fellowship for three years which allowed him to be enrolled in a doctoral program at Louisiana State University (LSU) in Baton Rouge, Louisiana. While at LSU, he has been involved in many projects directly and indirectly, giving support to his research group and other groups in the chemistry department under the supervision of Dr. Robert M. Strongin. He synthesized and studied new macrocyclic materials. In 2001, he received an LSU Research Award in Chemistry. He is a member of the American Chemical Society. Jorge Omar Escobedo Córdova is currently a candidate for the degree of Doctor of Philosophy in organic chemistry, which will be awarded on the December 2002 Commencement.