

**BENCH-SCALE COMPOST REACTORS SYSTEM
AND THE SELF-HEATING CAPABILITIES**

A Thesis

**Submitted to the Graduate Faculty of the
Louisiana State University and
Agricultural and Mechanical College
in partial fulfillment of the
requirements for the degree of
Master of Science in Civil Engineering**

in

The Department of Civil and Environmental Engineering

**by
Michael A. Vining
B.S., Texas A&M University, 1994
December 2002**

ACKNOWLEDGMENTS

First and foremost, I would like to thank my initial major professor and advisor Dr. Kyoung S. Ro who guided me throughout this project. In addition, I would also like to thank Dr. Donald D. Adrian who later became my major professor and advisor. I sincerely appreciate both men. Their constant support, encouragement and patience enabled me to complete this project.

I am grateful to my other committee members, Dr. W. David Constant, and Dr. John H. Pardue for their advice and suggestions for improvement. I am also extremely thankful for their patience and flexibility in completing this project.

In closing, I would like to thank my parents, Alden and Rosemarie Vining, for their love and guidance throughout my life.

TABLE OF CONTENTS

ACKNOWLEDGMENTS.....	ii
LIST OF TABLES.....	iv
LIST OF FIGURES.....	v
ABSTRACT.....	vii
CHAPTER 1. INTRODUCTION.....	1
CHAPTER 2. OBJECTIVES AND TASKS.....	4
CHAPTER 3. METHODOLOGY.....	5
3.1 COMPOST REACTOR SYSTEM.....	5
3.2 CHEMICAL ANALYSIS.....	8
3.3 COMPOST MATERIALS.....	8
3.4 EXPERIMENTAL SEQUENCE.....	10
3.5 OVERALL HEAT TRANSFER COEFFICIENTS OF THE COMPOST REACTOR SYSTEMS.....	10
CHAPTER 4. RESULTS AND DISCUSSION.....	13
4.1 OVERALL HEAT TRANSFER COEFFICIENTS OF COMPOST REACTORS.....	13
4.2 COMPOSTING WITH THREE DIFFERENT RECIPES RELEVANT TO LOUISIANA.....	13
CHAPTER 5. CONCLUSIONS.....	22
REFERENCES.....	23
APPENDIX A: WATER TEMPERATURE PROFILE DATA.....	24
APPENDIX B: WATER TEMPERATURE PROFILES.....	68
APPENDIX C: LINEARIZATION OF THE WATER TEMPERATURE PROFILES.....	75
APPENDIX D: TEMPERATURE PROFILE DATA OF COMPOST TRIALS.....	95
APPENDIX E. COMPOST TEMPERATURE PROFILES.....	143
VITA.....	147

LIST OF TABLES

Table 1 – Individual Reactor Component Dimensions.....	7
Table 2 – Sources of Compost Materials.....	9
Table 3 – Components and Characteristics of Compost Mix 1.....	9
Table 4 – Components and Characteristics of Compost Mix 2.....	9
Table 5 – Components and Characteristics of Compost Mix 3.....	9
Table 6 – Operating Parameters for Compost Mix 1.....	10
Table 7 – Operating Parameters for Compost Mix 2.....	10
Table 8 – Operating Parameters for Compost Mix 3.....	10
Table 9 – Linearization of Water Temperature Profiles and U Values Obtained.....	18

LIST OF FIGURES

Figure 1 - Bench-Scale Composting Reactor System.....	6
Figure 2 - Individual Compost Reactor Dimensions.....	7
Figure 3 - Linearization of the Water Temperature Profile R-01-3.5A Trial 1.....	14
Figure 4 - Linearization of the Water Temperature Profile R-10-12 Trial.....	15
Figure 5 - Temperature Profile of Water in R-01-3.5A.....	16
Figure 6 - Temperature Profile of Water in R-10-12.....	17
Figure 7 - Mix 2 Compost Temperature Profile.....	19
Figure 8 - Mix 2 Compost Temperature Profile.....	20
Figure B-1 - Temperature Profile of Water in R-01-3.5B.....	68
Figure B-2 - Temperature Profile of Water in R-01-6.5A.....	69
Figure B-3 - Temperature Profile of Water in R-01-6.5B.....	70
Figure B-4 - Temperature Profile of Water in R-01-8.5A.....	71
Figure B-5 - Temperature Profile of Water in R-01-8.5B.....	72
Figure B-6 - Temperature Profile of Water in R-04-12.....	73
Figure B-7 - Temperature Profile of Water in R-07-12.....	74
Figure C-1 - Linearization of the Water Temperature Profile for R-01-3.5A Trial 2.....	75
Figure C-2 - Linearization of the Water Temperature Profile for R-01-3.5A Trial 3.....	76
Figure C-3 - Linearization of the Water Temperature Profile for R-01-3.5B Trial 1.....	77
Figure C-4 - Linearization of the Water Temperature Profile for R-01-3.5B Trial 2.....	78
Figure C-5 - Linearization of the Water Temperature Profile for R-01-3.5B Trial 3.....	79
Figure C-6 - Linearization of the Water Temperature Profile for R-01-3.5B Trial 4.....	80
Figure C-7 - Linearization of the Water Temperature Profile for R-01-6.5A Trial 1.....	81

Figure C-8 - Linearization of the Water Temperature Profile for R-01-6.5A Trial 2.....	82
Figure C-9 - Linearization of the Water Temperature Profile for R-01-6.5A Trial 3.....	83
Figure C-10 - Linearization of the Water Temperature Profile for R-01-6.5B Trial 1.....	84
Figure C-11 - Linearization of the Water Temperature Profile for R-01-6.5B Trial 2.....	85
Figure C-12 - Linearization of the Water Temperature Profile for R-01-6.5B Trial 3.....	86
Figure C-13 - Linearization of the Water Temperature Profile for R-01-8.5A Trial 1.....	87
Figure C-14 - Linearization of the Water Temperature Profile for R-01-8.5A Trial 2.....	88
Figure C-15 - Linearization of the Water Temperature Profile for R-01-8.5A Trial 3.....	89
Figure C-16 - Linearization of the Water Temperature Profile for R-01-8.5B Trial 1.....	90
Figure C-17 - Linearization of the Water Temperature Profile for R-01-8.5B Trial 2.....	91
Figure C-18 - Linearization of the Water Temperature Profile for R-01-8.5B Trial 3.....	92
Figure C-19 - Linearization of the Water Temperature Profile for R-04-12 Trial 1.....	93
Figure C-20 - Linearization of the Water Temperature Profile for R-07-12 Trial 1.....	94
Figure E-1 - Mix 1 Compost Temperature Profile for Large Reactors.....	143
Figure E-2 - Mix 1 Compost Temperature Profile for Small Reactors.....	144
Figure E-3 - Mix 3 Compost Temperature Profile for Large Reactors.....	145
Figure E-4 - Mix 3 Compost Temperature Profile For Small Reactors.....	146

ABSTRACT

Less expensive bench-scale composting reactor systems which can mimic actual composting process via self-heating are needed. One can achieve such systems without using the expensive temperature feed-back control by properly insulating the bench composting reactors. However, the knowledge of heat generation and transfer in bench composting reactors is essential in properly designing such inexpensive insulation systems.

All compost trial temperature profiles illustrated initial elevated temperature levels followed by a slow gradual temperature decreasing phase. Of all of the variables, the airflow rate, the volume and the overall heat transfer coefficient, seem to have the greatest impact on producing thermophilic temperatures. From the data obtained from the experiments, some design criteria are suggested. An air flow rate of $1 \text{ m}^3/(\text{kg-VS-d})$, an heat transfer coefficient less than $.010 \text{ J}/(\text{m}^2\text{-K-d})$, and a compost volume of ten liters or greater value are parameter guidelines for future research. The guideline of moisture content equal to or greater than 30% held.

With the experiments being a success in producing self-heating elevated temperatures, it is obvious that the precise parameters necessary are still vague. Additional future study is needed to specify the parameters necessary for optimal composting. A better understanding of composting kinetics, energy values of compost components, and mass transfer during water evaporation is needed.

CHAPTER 1. INTRODUCTION

The process of composting has been utilized around the world for years. Under controlled conditions, composting transforms organic materials such as plant matter through complex biogeochemical decomposition into a soil-like material called compost. Traditionally composting has been used by farmers to produce compost to improve soil fertility. Today, composting is also used to reduce the volume of municipal solid wastes (MSW) and turn organic wastes into valuable end products as landfill siting becomes more difficult and expensive. It is a commonplace for wastes such as lawn clippings, hay, kitchen wastes, leaves, manure and wood chips to be composted with sludge produced from publicly owned treatment works (POTWs). In 1991, there were 240 such composting projects in the United States (Outwater, 1994). As people become more aware of the environment, the practice of composting will continue to increase.

Recently, the composting approach has been used as a bioremediation tool for cleaning contaminated soils. The compost microorganisms were found to be effective in mineralizing and/or biotransforming many hazardous chemicals contaminating our soils. Suler (1979), Ryan et al. (1988), Ro et al. (1997), Preston et al. (1996), Wade et al. (1997), William and Myler (1990), all found promising results in their research of composting as a bioremediation method.

Although composting has a great potential to become a cost-effective alternative to treat the soils contaminated with hazardous contaminants, this remediation technology is still in its embryonic stage. Many factors such as physicochemical, biological, and thermodynamical characteristics of compost matrix, contaminants, and environmental conditions will significantly affect the degradation patterns of contaminants and eventually determine the success of the technology. Unfortunately, much of microbial thermogenesis and the heat transfer aspects of composting are not fully understood to date due to the fact that composting has been practiced for a long time as a form of art, rather than based on sound scientific and engineering principles. The microbial thermogenesis and heat transfer control the compost temperature, which strongly affects the degradation of compost and the fate and biotransformation of contaminants. Thorough understanding of the thermodynamics of composting is vital for successfully implementing the remediation composting technology.

Scientists and engineers study the fate of target chemicals and conduct preliminary feasibility and optimization of the remediation composting process using small bench-scale composting reactors before scaling up to pilot- or field-scale operations. However, the bench-scale composting normally cannot achieve the critical thermophilic temperature (i.e., temperature generally higher than 50 °C) by self-heating mechanisms as found in field composting. A relatively high surface area to volume ratio compared to field compost piles results in high conductive and convective heat loss. The heat generated from degrading organic substrates may not be enough to raise and maintain the thermophilic compost temperature. It has been a common perception among composting researchers and practitioners that the minimum size of a pilot compost pile must be at least 25 to 50 cubic yards in order to retain the heat (Hanif, 1995). The need for this large compost pile to achieve the thermophilic temperature is a major impediment for researchers and practitioners because of high capital and operating costs associated with such large size compost piles. It will simply be too expensive to obtain all necessary data to determine preliminary feasibility or to optimize remediation composting.

In order to overcome this problem, external heating mechanisms have been used to enable the complete composting process to occur. For instance, ASTM D5338 (1992) method uses incubators to externally control the temperature of the compost within a reactor system. The incubator in which bench-compost reactors are placed is programmed to set the composting temperature at 35 °C for one day to simulate the initial mesophilic phase, 58 °C for four days, and 50 °C for 28 days to simulate the optimum thermophilic conditions. Finally the mesophilic curing phase is simulated at 35 °C for 45 days. By presetting the temperatures and interval, the reproducibility of data may be improved, but many experts have argued that the ASTM method does not represent the actual composting process. These external heating mechanisms do not really mimic the actual composting process in which self-heating is induced.

A few other researchers used feed-back temperature control and heating systems in order to minimize the heat loss and were able to maintain self-heating induced thermophilic conditions (Cook et al., 1994; Hogan et al., 1989; Magalhaes et al., 1993; Wade et al., 1997). These temperature feed-back systems are very expensive. For instance, the system used by Wade et al. (1997) costs more than \$75,000 for five 50-L reactors. These small bench-scale remediation composting systems require much more precise design and operational parameters in order to be successful. Thorough knowledge of thermogenesis and the heat

transfer characteristics of composting reactors is vital in properly designing and operating bench-scale composting reactors. Unfortunately, the design and operations of most compost systems have been largely based on empirical knowledge, and much of the systematic engineering principles applied to other remediation technologies are absent. As a result, successful design and operation of one type of bench remediation system may not guarantee the success of other types of composting systems.

There is a need for less expensive bench-scale composting reactor systems which can mimic actual composting process via self-heating. One can achieve such systems without using the expensive temperature feed-back control by properly insulating the bench composting reactors. However, the knowledge of heat generation and transfer of bench composting reactors is essential in properly designing of such inexpensive insulation systems. This is the motivation of the current research.

CHAPTER 2. OBJECTIVE AND TASKS

The objective of the research is to study the heat transfer of the bench-scale composting reactors and to investigate the heat transfer characteristics of insulated bench-scale composting reactors. Following are specific tasks to achieve the objective.

1. Construct bench-scale, self-heating compost reactor system.
2. Conduct heat transfer experiments using the bench-scale composting reactor systems.
3. Conduct actual composting trials with a few compost recipes.

CHAPTER 3. METHODOLOGY

3.1 COMPOST REACTOR SYSTEM

The compost reactor system consists of three pairs of reactors and three independent reactors to comprise a total of nine reactors. Each pair of reactors are all of the same volume with an increasing insulation thickness. The three independent reactors have increasing volumes with the same insulation thickness. Each of the reactors are constructed of schedule 40 PVC pipe and are insulated with polystyrene. The compost reactor system is shown in Figure 1.

The air first passes through two condensers in series. Within the condensers, glass wool scrubs the air to remove moisture and impurities. The air is then distributed to each of the nine reactors. Once diverted toward each reactor, the volume of air is regulated by flow meters. Then the air flows into a humidifier to saturate the air with deionized water. From the humidifier, the flow of air is directed through the reactor and then vented into the atmosphere.

The three pairs of reactors are constructed of two four-inch female adapters linked by a piece of four inch diameter pipe. Within these fittings, a screen is placed on the bottom side of the reactor to prevent any of the compost from clogging the air inlet and to uniformly distribute the air. Each of the pairs of reactors are placed within cylinders cut out of one, one and a half and two feet diameter polystyrene respectively. Three other reactors are constructed with two six inch caps linked by a piece of six inch diameter pipe. A screen is also located on the bottom side of the reactor to prevent any of the compost from clogging the air inlet. The three reactors are placed within cylindrical polystyrene configuring an insulation of one foot around each reactor. An individual reactor is shown in Figure 2 and the associated dimensions of each reactor is shown in Table 1.

Each reactor has a specific notation which define its parameters. The notation is a series of three letter and numeral combinations separated by hyphens. The first letter and number combination, the letter “R” for all reactor notations, is an abbreviation for the word “Reactor”. The second letter and number combination designates the approximate volume of the reactor. The third letter and number combination designates the insulation thickness on the side of the reactor and also differentiates between two reactors of identical volumes and side insulation. Two examples are as follows:

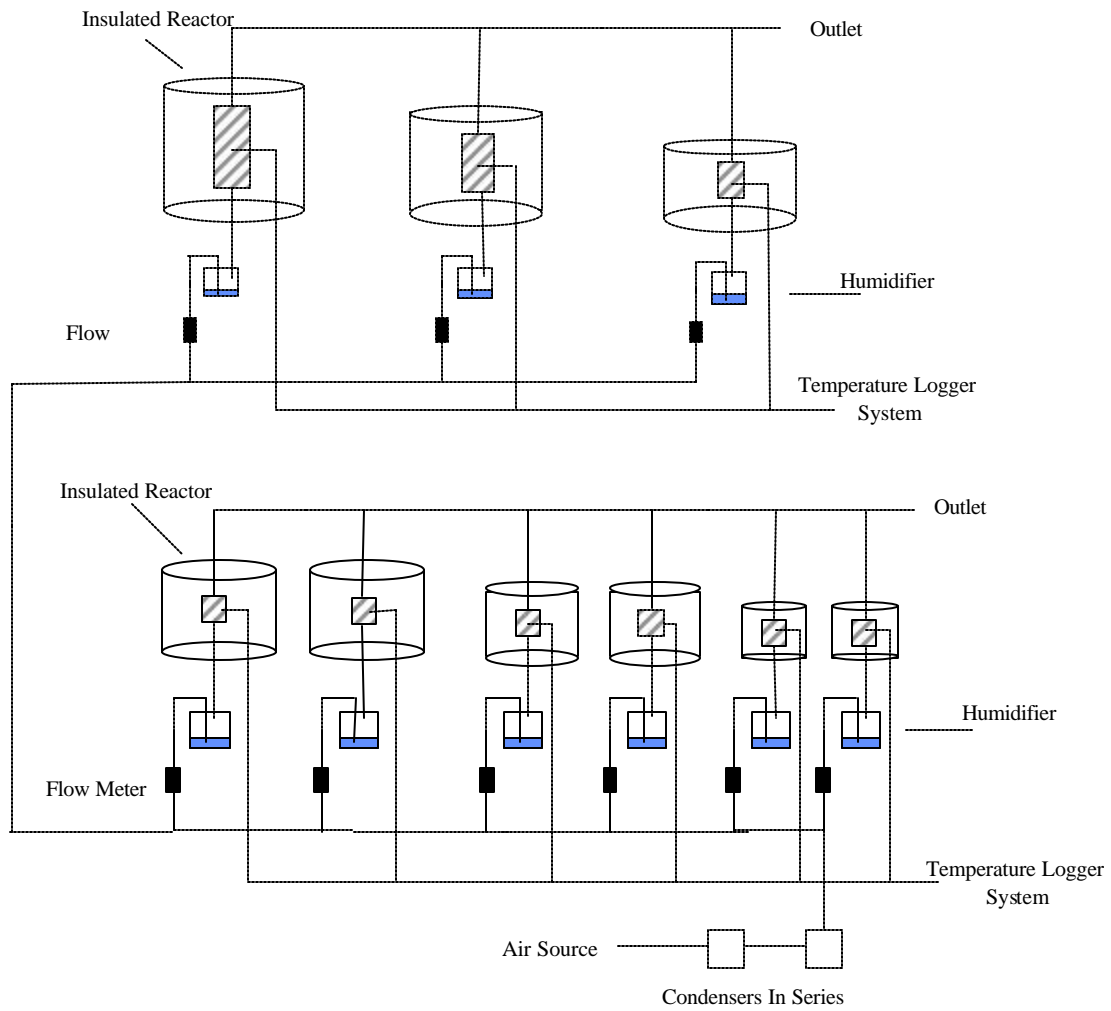

FIGURE 1. Bench-Scale Composting Reactor System

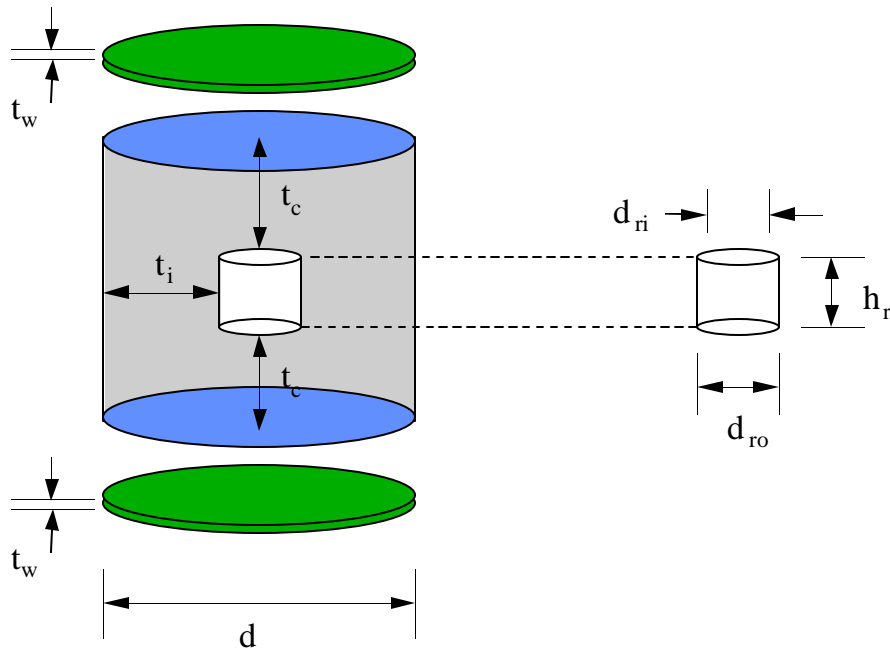

FIGURE 2. Individual Compost Reactor Dimensions

TABLE 1 - Individual Reactor Component Dimensions

Reactor	Outside Diameter of Insulation (d)	Thickness of Wood (t_w)	Height of Top Cover (t_c)	Inside Diameter of PVC Reactor (d_{ri})	Outside Diameter of PVC Reactor (d_{ro})	Height of Reactor (h_r)	Thickness of Insulation (t_i)
R-01-3.5A	0.3048	0.0127	0.0635	0.1143	0.1270	0.1778	0.0825
R-01-3.5B	0.3048	0.0127	0.0635	0.1143	0.1270	0.1778	0.0825
R-01-6.5A	0.4572	0.0127	0.1397	0.1143	0.1270	0.1778	0.1524
R-01-6.5B	0.4572	0.0127	0.1397	0.1143	0.1270	0.1778	0.1524
R-01-8.5A	0.6096	0.0127	0.2032	0.1143	0.1270	0.1778	0.2349
R-01-8.5B	0.6096	0.0127	0.2032	0.1143	0.1270	0.1778	0.2349
R-04-12	0.7620	0.0127	0.3480	0.1575	0.1460	0.254	0.3016
R-07-12	0.7620	0.0127	0.3480	0.1575	0.1460	0.4318	0.3016
R-10-12	0.7620	0.0127	0.3480	0.1575	0.1460	0.5842	0.3016

* ALL DIMENSIONS ARE IN M.

? Reactor R-01-6.5B

This reactor's notation states that it is the "B" reactor of approximately one liter volume with six and one half inches of side insulation.

? Reactor R-07-12

This reactor's notation states that it is the only reactor of approximately seven liters with twelve inches of side insulation

3.2 CHEMICAL ANALYSIS

Chemical analysis of the various compost mixtures and individual wastes were performed throughout the data collection. The solid test method was performed according to the Standard Methods (APHA, 1995) with minimal alterations, to determine dry solids (DS), percent moisture (M), volatile solids (VS) and non-volatile solids (NVS). The moisture content is determined by oven-drying the compost at 104 °C for 24 hours and subtracting the final weight from the initial weight and dividing this number by the initial weight. The volatile solids and non-volatile solids are determined by placing the remaining compost from the moisture content procedure into a furnace at 550 °C for thirty minutes. The difference between the weight of the sample before and after it has been heated at 550°C, estimates the weight of NVS. The difference between the weight of DS and the weight of NVS, estimates the weight of VS.

The Carbon to Nitrogen ratio was determined first by drying each sample for a twenty-four hour period at a temperature of 65 °C. This temperature was chosen to remove the moisture within the waste, but not to remove any organic content in which carbon and nitrogen is present. Once the waste is dried, it is ground into a fine dust. The dust is analyzed by the use of an elemental analyzer (Heraeus CHN-O-Rapid) to determine the amount of carbon and nitrogen, respectively. The Heraeus-CHN-O-Rapid analyzer works by combusting a sample of known mass at high temperatures in the presence of oxygen. With the assistance of some catalytic oxidation agents and reduction agents, all nitrogen is converted to N₂, all carbon is converted to CO₂, all hydrogen is converted to H₂O and all sulfur is converted to SO₂. All other gaseous products are chemically trapped. The four analyte gases are then dynamically separated on specific purge and trap columns, and detected one at a time.

3.3 COMPOST MATERIALS

Throughout the study various types of compost components were analyzed. The wastes which were chosen are all common to South Louisiana. Table 2 lists the assortment of the compost components and the sources.

TABLE 2 - Sources of Compost Materials

Components	Source
Bagasse	Louisiana State University Organic Recycle Research Center, Baton Rouge
Catfish Heads	Tony's Seafood, Baton Rouge
Cotton	Louisiana State University Organic Recycle Research Center, Baton Rouge
Cow Manure	Louisiana State University Dairy Farm Facility, Baton Rouge
Crawfish	Tony's Seafood, Baton Rouge
Lettuce	Albertson Grocery Store, Baton Rouge
Pizza Crust	Mr. Gatti's, Baton Rouge
Potatoes	Albertson Grocery Store, Baton Rouge

A solid test was performed on each individual waste as well as a determination of the carbon to nitrogen ratio. The data gathered from this analysis were studied and three different compost mixes were compiled. Each compost mix represented factors considered to be ideal for composting. Tables 3, 4, and 5 show the components and characteristics of each waste in the compost mix.

TABLE 3 - Components and Characteristics of Compost Mix 1

Waste	Volume (%)	Wet Weight (g)	Moisture (%)	Dry Weight (g)	VS (g/g DS)	Carbon (%)	Nitrogen (%)	C/N Ratio
Bagasse	46.2	1743.2	52.2	833.9	0.94	44.34	0.38	116
Cotton Wastes	30.8	681.4	16.3	570.6	0.81	43.58	1.79	24
Cow Manure	15.4	5500.6	82.6	956.6	0.86	38.36	2.55	15
Crawfish Heads	7.7	-	72.2	-	0.56	37.10	5.34	7

TABLE 4 - Components and Characteristics of Compost Mix 2

Waste	Volume (%)	Wet Weight (g)	Moisture (%)	Dry Weight (g)	VS (g/g DS)	Carbon (%)	Nitrogen (%)	C/N Ratio
Bagasse	46.2	1743.2	52.2	833.9	0.94	44.34	0.38	116
Cotton Wastes	23.1	511.0	16.3	427.9	0.81	43.58	1.79	24
Cow Manure	30.8	11001.2	82.6	1913.1	0.86	38.36	2.55	15

TABLE 5 - Components and Characteristics of Compost Mix 3

Waste	Volume (%)	Wet Weight (g)	Moisture (%)	Dry Weight (g)	VS (g/g DS)	Carbon (%)	Nitrogen (%)	C/N Ratio
Bagasse	46.2	1743.2	52.2	833.9	0.94	44.34	0.38	116
Cotton Wastes	23.1	511.0	16.3	427.9	0.81	43.58	1.79	24
Cow Manure	23.1	5527.7	82.6	1913.1	0.86	38.36	2.55	15
Potatoes	7.7	952.9	74.0	198.3	0.94	36.51	3.58	1

Tables 6, 7, and 8 describe operating conditions of the composting experiments. The initial energy value for each mix was obtained by using reference material stating energy values for each of the components in the mix. By using the weighted average method, the initial energy of the complete mix was calculated.

TABLE 6 - Operating Parameters for Compost Mix 1

Reactor	Wet Weight (g)	Dry weight (g)	VS (g)	Initial Energy (J)	Air Flow (L/d)
R-01-3.5B	190	65.66	49.90	3942	57
R-01-6.5B	189	65.32	49.64	3942	57
R-01-8.5B	189	65.32	49.64	3942	57
R-04-12	757	261.62	198.83	3942	113
R-07-12	1323	457.23	347.49	3942	113
R-10-12	1889	652.84	496.16	3942	113

TABLE 7. Operating Parameters for Compost Mix 2

Reactor	Wet Weight (g)	Dry weight (g)	VS (g)	Initial Energy (J)	Air Flow (L/d)
R-01-3.5B	302	91.72	79.15	4138	136
R-01-6.5B	302	91.72	79.15	4138	136
R-01-8.5B	302	91.72	79.15	4138	136
R-04-12	1204	365.65	315.56	4138	340
R-07-12	2107	639.90	552.23	4138	679
R-10-12	3010	914.14	788.90	4138	1019

TABLE 8 - Operating Parameters for Compost Mix 3

Reactor	Wet Weight (g)	Dry weight (g)	VS (g)	Initial Energy (J)	Air Flow (L/d)
R-01-3.5B	242	78.05	65.95	4188	136
R-01-6.5B	242	78.05	65.95	4188	136
R-01-8.5B	242	78.05	65.95	4188	136
R-04-12	968	312.18	263.79	4188	340
R-07-12	1694	546.32	461.64	4188	679
R-10-12	2420	780.45	659.48	4188	1019

3.4 EXPERIMENTAL SQUENCE

The three sets of reactors were constructed initially. Upon completion of the reactor sets and compost system, three to four water temperature profile trials for each reactor were performed. After the water temperature profiles were completed, a preliminary compost trial was performed. The preliminary compost trial did not produce the anticipated elevated temperatures, as a result, the three reactors with larger volumes and greater insulation were constructed. Only one water temperature profile was performed for each larger reactor. Upon completion of these water temperature profiles, the three compost experiments were initiated. Each experiment utilized the compositions listed in Tables 6, 7, and 8.

3.5 OVERALL HEAT TRANSFER COEFFICIENTS OF THE COMPOST REACTOR SYSTEMS

The overall heat transfer coefficients (U) of each of the reactors in the reactor system are important in understanding and analyzing heat transfer characteristics of the compost system. Assuming negligible heat

loss due to thermal radiation, the following equation is produced from an energy balance around the compost reactor:

$$\frac{dT}{dt} \cdot C_r \cdot V \cdot \rho = \text{Energy Inflow} + \text{Energy Generation} - U \cdot A \cdot (T - T_\infty) \quad (1)$$

Where,

- T = compost temperature (K),
- T_∞ = ambient temperature (K),
- t = time (s),
- C_r = specific heat capacity of compost (J/kg-K),
- V = volume of compost (m^3),
- ρ = dry density of compost (kg/m^3),
- U = overall heat transfer coefficient ($\text{W}/\text{m}^2\text{-K}$),
- A = surface area (m^2).

In order to estimate the overall heat transfer coefficient of the compost reactor, hot water (60 - 80 °C) was placed in the reactors. The decline in temperature was monitored for a specified time enabling the internal temperature to come into equilibrium with the ambient temperature. The temperature profile trials were duplicated numerous times to assure reliability of data. Temperatures of the water in the reactors were measured and recorded every minute for 2 to 6 days using temperature sensor and data logger systems (StowAway™, Ben Meadows Co.).

Without any energy inflow to the reactor and generation, equation 1 can be integrated over time.

$$\int_{T_1}^T \frac{dT}{(T - T_\infty)} = \int_{t_1}^t - \frac{U \cdot A}{C_{rw} \cdot V_w \cdot \rho_w} \cdot dt \quad (2)$$

- where,
- T_1 = water temperature at time t_1 (K),
 - T = water temperature at time t (K),
 - C_{pw} = specific heat capacity of water (J/kg-K),
 - V_w = volume of water (m^3),
 - ρ_w = density of water (kg/m^3).

If we assume U is constant over the temperature ranges we tested, equation 2 become

$$\ln\left(\frac{T - T_\infty}{T_1 - T_\infty}\right) = - \frac{U \cdot A}{C_{rw} \cdot V_w \cdot \rho_w} \cdot (t - t_1) \quad (3)$$

The values of U for each experiment run was determined graphically using equation 3. The data were

plotted $\ln\left(\frac{T - T_\infty}{T_i - T_\infty}\right)$ vs. $t - t_1$, and the slopes were estimated using linear regression.

CHAPTER 4. RESULTS AND DISCUSSION

4.1 OVERALL HEAT TRANSFER COEFFICIENTS OF COMPOSTING REACTORS

The reactors' water temperature profile trials were duplicated at least twice for the smaller reactors, but the water temperature profile trials were only performed once for the larger reactors. The abbreviated set of data points for all water temperature profile trials are shown in Appendix A. Figures 3 and 4 illustrate Trial 1 of the water temperature profiles for R-01-3.5A and R-10-12 reactors. Each figure presents a similar pattern. The initial temperature of the water varies between the 56°C and 88°C. The figures show the water temperature decreasing rapidly initially and then the profile flattens as time continues. The initial rapid decrease in temperature is most likely a result of the reactor system coming into equilibrium. Once equilibrium has occurred, the rate of temperature decrease diminishes. The plots of the water temperature profile trials for the remaining reactor systems are shown in Appendix B.

The data obtained from the water temperature trials were plotted using equation 3. Figures 5 and 6 illustrate the linearization of the water temperature profile for the R-01-3.5A, Trial 1, and R-10-12, Trial 1. The graphs were curve fit using the linear regression to obtain the slope and R^2 values. The U value were obtained by incorporating the slopes for each reactor into equation 3. All R^2 values for the Linearization exceed .9900 except for R-01-8.5B, Trail 2, and R-01-6.5B, Trail 1. Their values are .9846 and .9767 respectively. The remaining plots of the linearization of the water temperature profile are shown in Appendix C. Table 9 summarizes the U value obtained.

4.2 COMPOSTING WITH THREE DIFFERENT RECIPES RELEVANT TO LOUISIANA

Three different compost mixes were used throughout the data collection. During the first compost mix, air was introduced into the system for period of one hour a day. The temperature profile produced initial elevated temperatures into the 50°C range. The second and third compost mix produced elevated temperature up the 70°C range. Air was introduced into the system at a flow rate of approximately 1m³/kg-VS-d during Trial 1 and Trial 2. Each individual reactor produced an unique temperature profile for each of the mixes. Figure 7 shows the larger reactors and the corresponding inlet air temperature profiles for Mix 2. Figure 8 shows the smaller reactors and the corresponding inlet air temperature

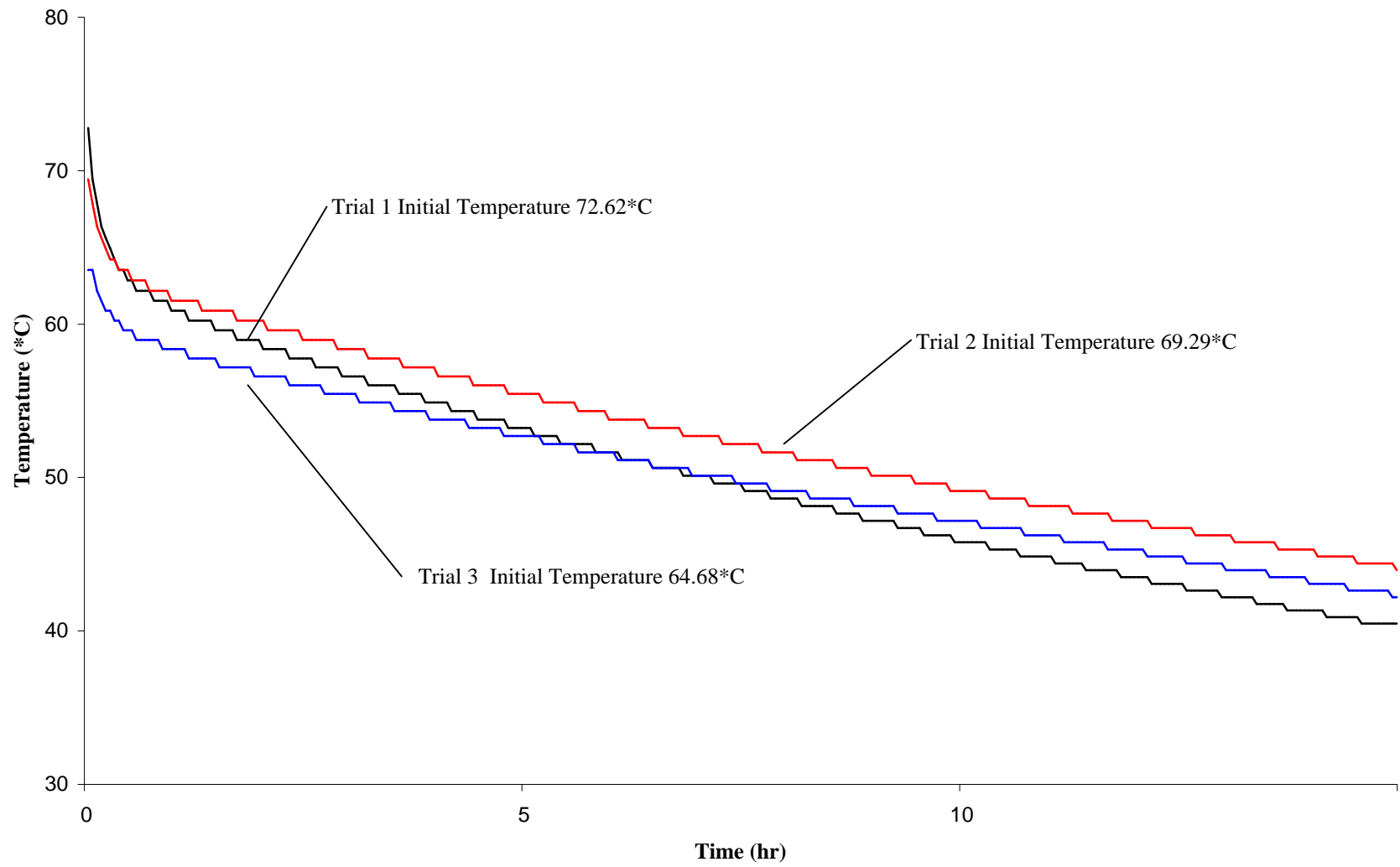

FIGURE 3. Temperature Profile of Water in R-01-3.5A

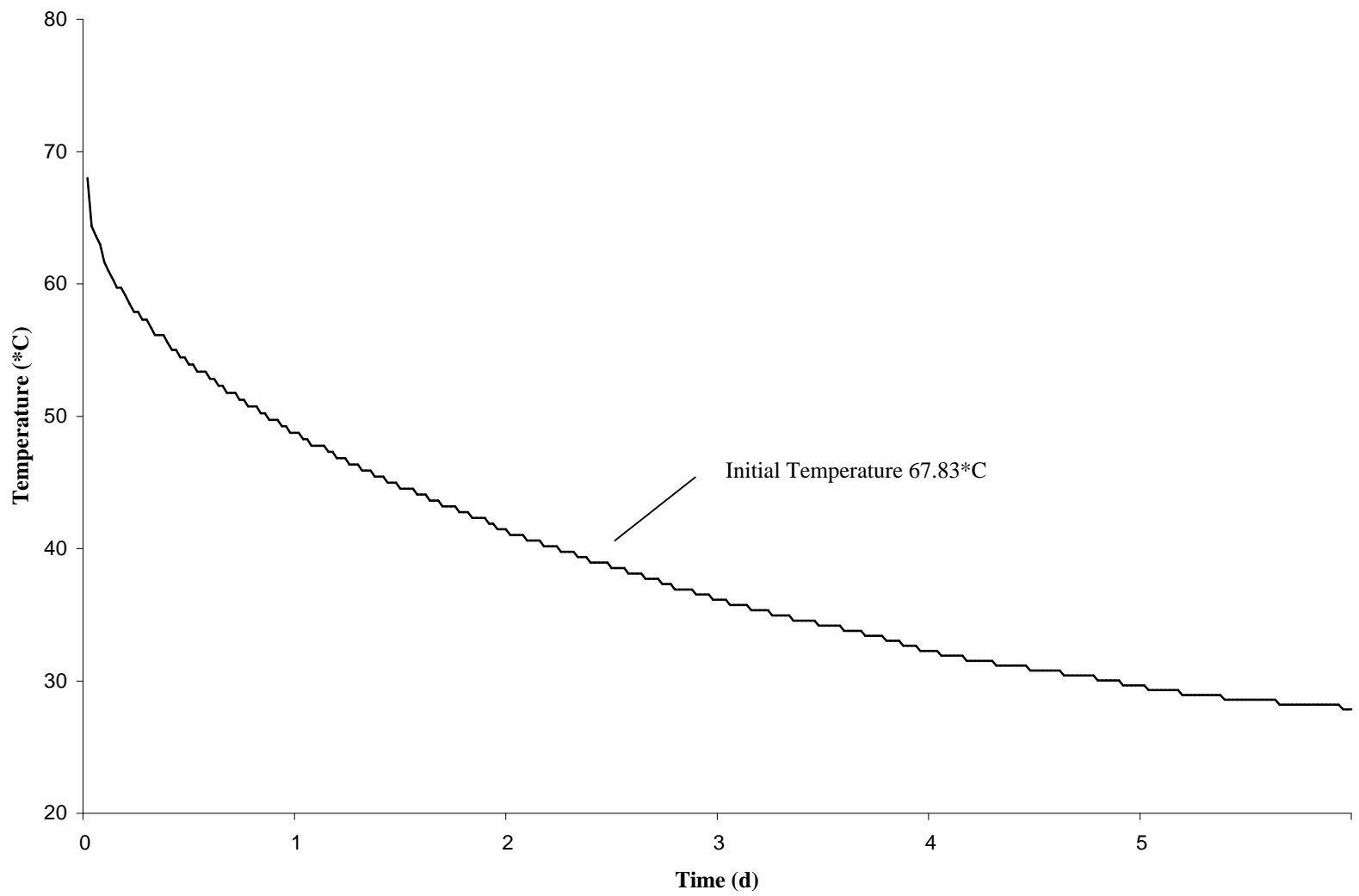

FIGURE 4. Temperature Profile of Water in R-10-12

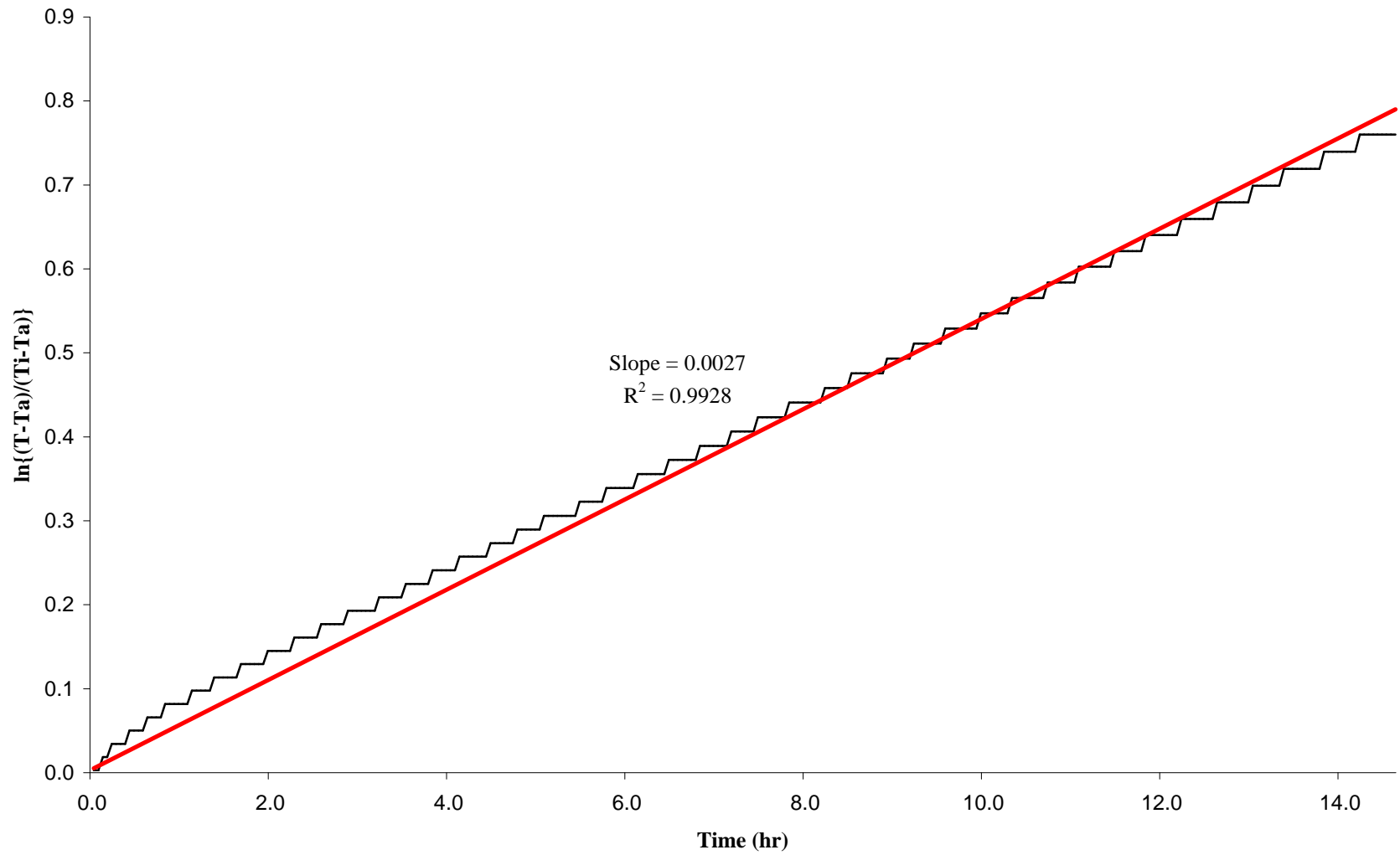

FIGURE 5. Linearization of the Water Temperature Profile for R-01-3.5A Trial 1

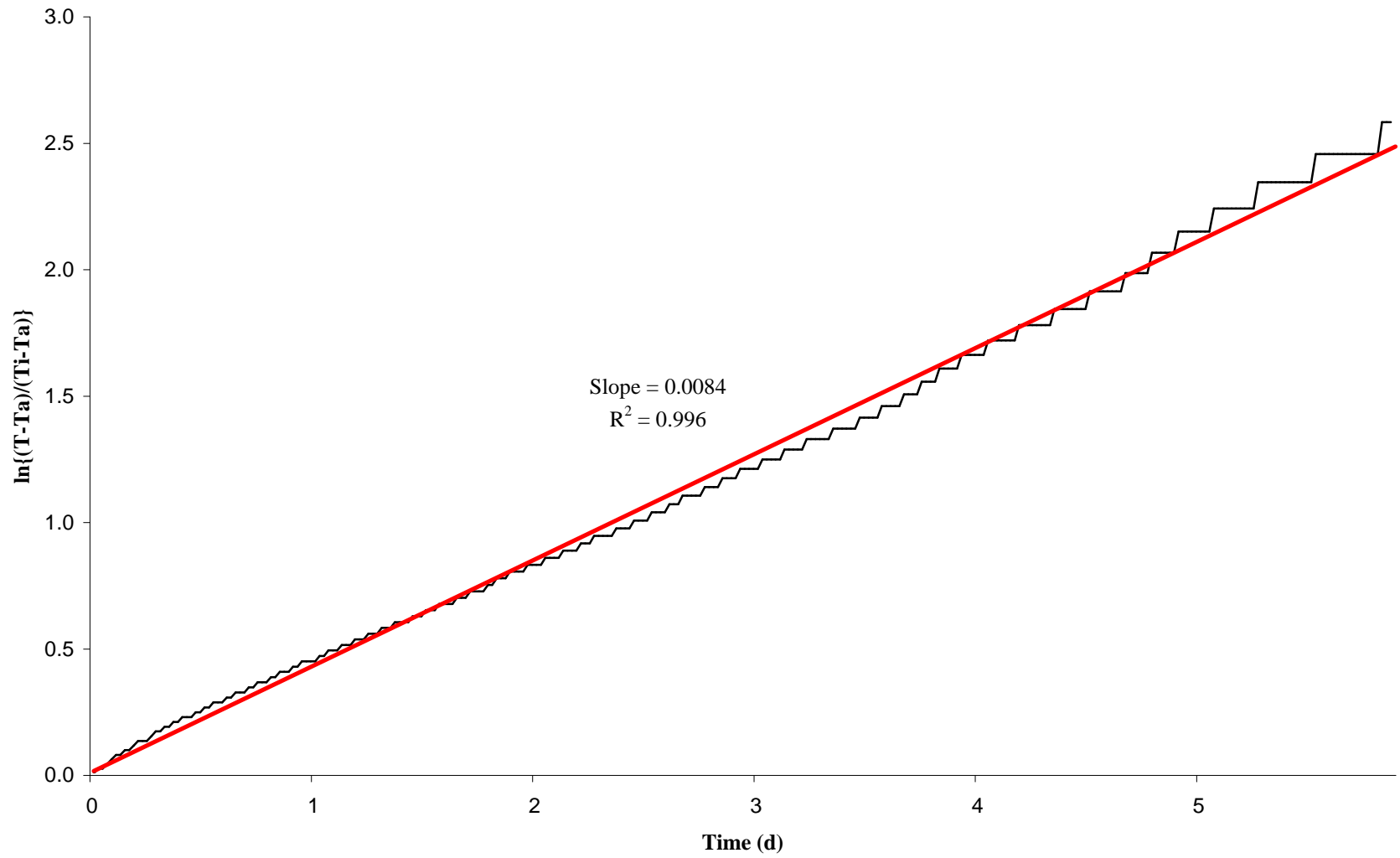

FIGURE 6. Linearization Of The Water Temperature Profile for R-10-12

TABLE 9. Linearization of Water Temperature Profiles and U Values Obtained

Reactor	U (J/m²* K* d)	Standard Deviation
R-01-3.5A	0.0974	0.0093
R-01-3.5B	0.0925	0.0275
R-01-6.5A	0.0453	0.0082
R-01-6.5B	0.0500	0.0117
R-01-8.5A	0.0104	0.0059
R-01-8.5B	0.0192	0.0028
R-04-12	0.0021	
R-07-12	0.0026	
R-10-12	0.0028	

profiles for Mix 2. These two figures illustrate the typical temperature profile pattern of the three compost mixes. Figures showing Mix 1 and Mix 3 are in appendix E. The data supporting all temperature profiles is presented in Appendix D.

The temperatures produced by each reactor are a function of the characteristics and parameters described in the previous tables. In almost all cases, the reactors produce increasing temperature initially and then the temperature decreases until day six of composting. Thermophilic temperatures were only obtained in the R-10-12 reactor during the Mix 2 and Mix 3 trials. The R-10-12 reactors all contained similar values for DS, VS, BVS and Total Initial Energy. The values were the greatest for all reactors resulting from a larger volume of materials. A notable difference in the R-10-12 reactors is the amount of air flow introduced into each reactor. Mix 1 inlet air flow is much less compared to Mix 2 and Mix 3. The minimal amount of inlet air flow may have not allowed for thermophilic temperatures to be produced.

All three mixes contain an initial energy content of approximately 4000. The wet weight, dry weight, VS and BVS of the three mixes are all within the same order of magnitude for each size reactor. The heat transfer coefficient is the largest for the R-01-3.5 reactors and smallest for the R-04, 07, 10-12

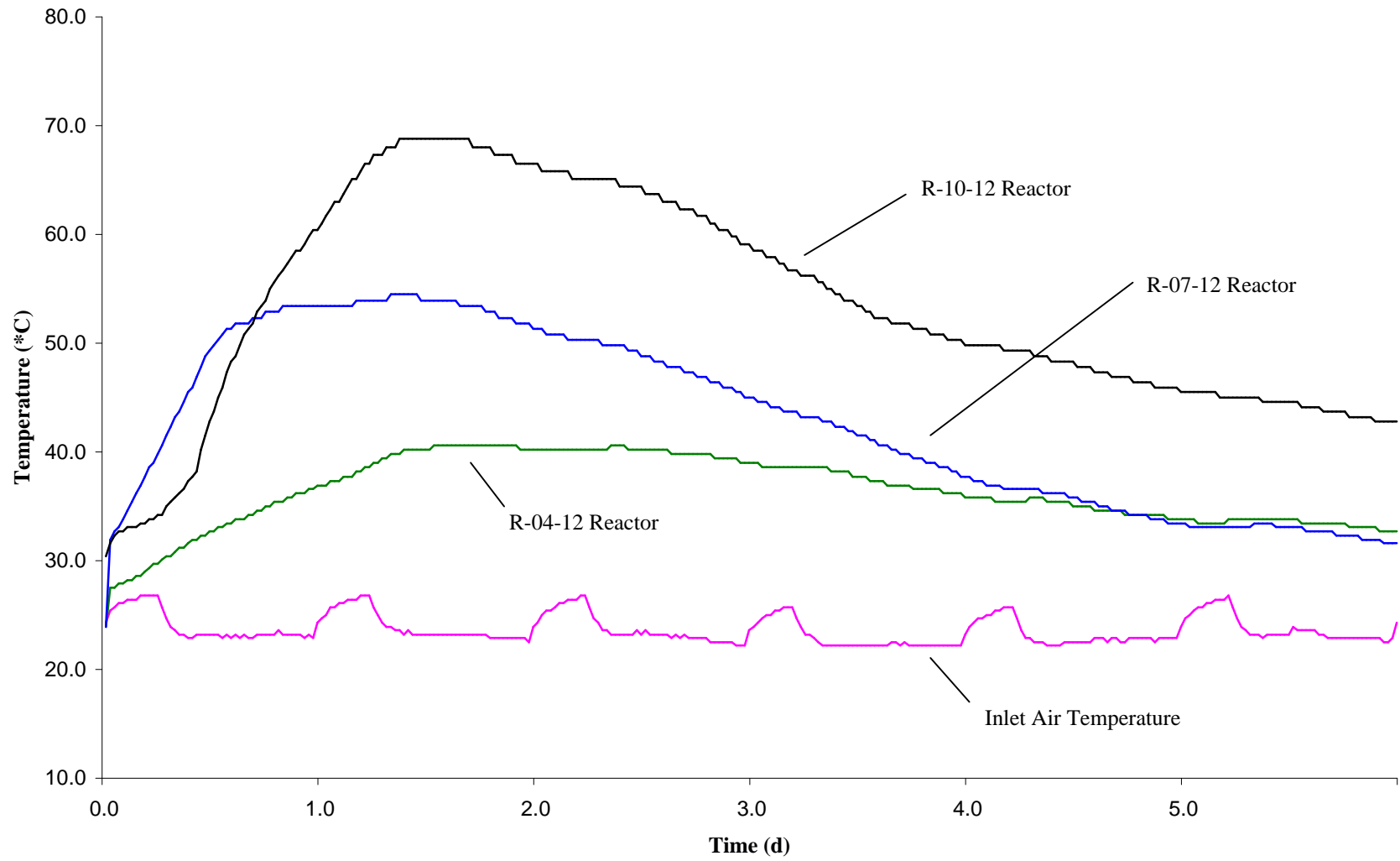

FIGURE 7. Mix 2 Compost Temperature Profiles for Large Reactors

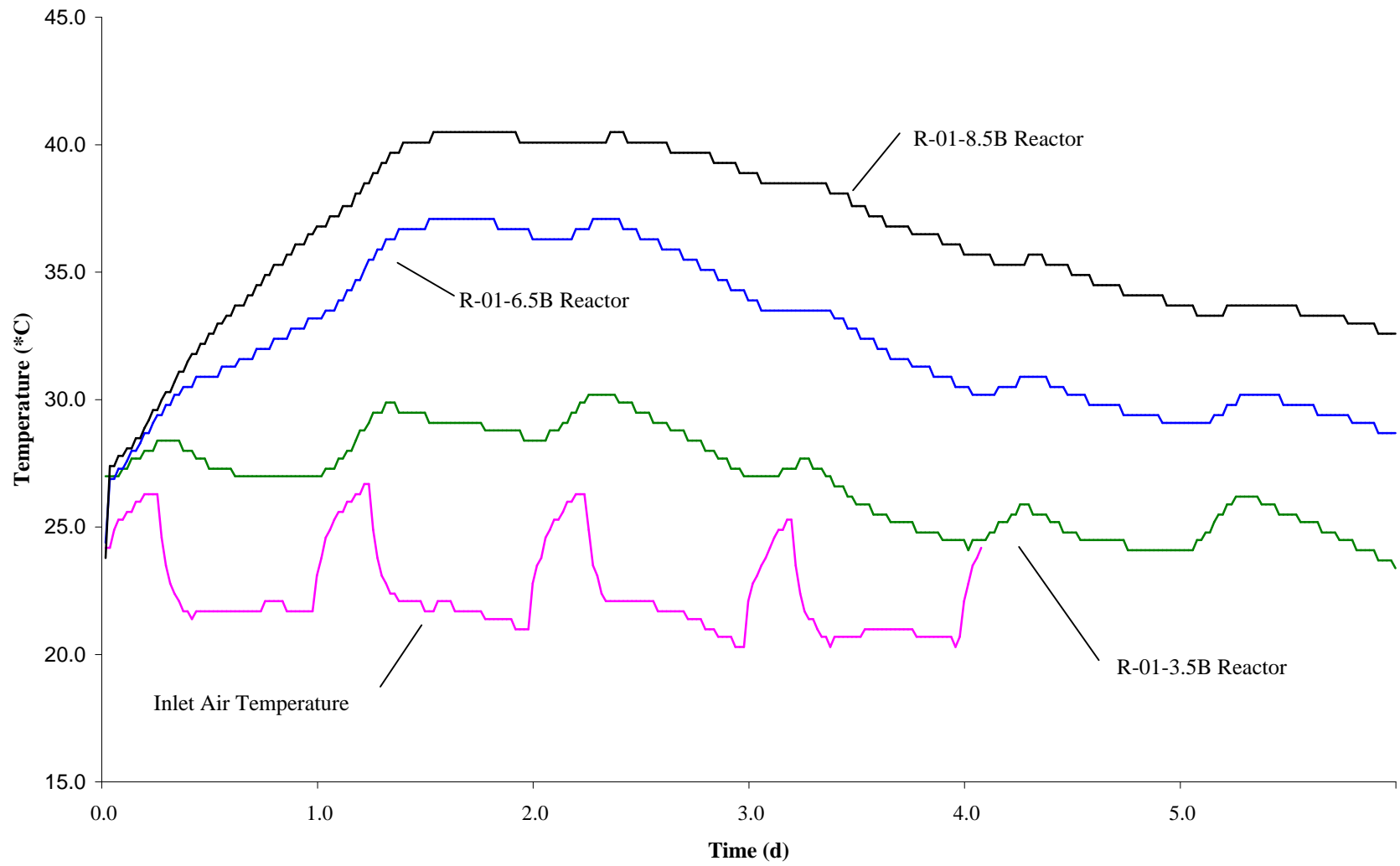

FIGURE 8. Mix 2 Compost Temperature Profiles For Small Reactors

reactors, therefore more heat is capable of being transferred from the reactors with less insulation thickness.

Based on these experiments, the initial observation suggests certain design parameters are necessary to achieve thermophilic temperatures. Not only is the amount of compost material required, but also the chemical make-up is important. A compost mix of adequate, but smaller mass with sufficient DS, VS and BVS content should produce thermophilic temperatures better than a larger mass of compost matrix with inadequate chemical content while still maintaining a minimal moisture content. The data also suggest an U value less than $.010 \text{ J}/(\text{m}^2\text{-K-d})$ as well as an air flow rate of $1 \text{ m}^3/(\text{kg-VS-d})$ should be used as a guide line. While maintaining an air flow rate of $1 \text{ m}^3/(\text{kg-VS-d})$, Mix 2 and Mix 3 R-10-12 reactors produced thermophilic temperatures. The Mix 1 R-10-12 reactor did not produce thermophilic temperatures with an air flow rate greater than of $1 \text{ m}^3/(\text{kg-VS-d})$. The higher flow rate may have had a cooling effect on the compost mix in addition to providing an oxygen supply.

The reactors constructed for these experiments are representative of field scale composting. In a field scale compost pile, the outer layer of material performs the same function as the polystyrene insulation does for the bench-scale reactors. The thermophilic temperatures are produced in the core of the field scale compost pile just as the thermophilic temperatures are produced at the core of the bench-scale reactors. The heating devices of externally heated reactors control the core temperature of the compost. The heating devices may allow a compost mix to achieve thermophilic conditions, when it would otherwise be impossible.

CHAPTER 5. CONCLUSIONS

Self-heating of bench-scale composting can be obtained without the use of high-priced equipment. The compost reactor system used in these experiments, although crude, can be utilized as a foundation in development and design of future bench-scale compost reactors system.

Thermophilic temperatures can be produced enabling the complete breakdown of the compost matrix. The time period of thermophilic temperatures in the experiments were limited, suggesting that the complete breakdown of the compost matrix did not occur. With this noted, changes to the reactor system are necessary.

All compost trial temperature profiles illustrated initial elevated temperature levels followed by a slow gradual temperature decreasing phase. Of all of the variables, the airflow rate, the volume and the overall heat transfer coefficient seem to have the greatest impact on producing thermophilic temperatures. From the data obtained from the experiments, some design criteria is suggested. An air flow rate of $1 \text{ m}^3/(\text{kg-VS-d})$, an heat transfer coefficient less than $.010 \text{ J}/(\text{m}^2\text{-K-d})$ and a compost volume of ten liters or greater value are parameter guidelines for future research. The guideline of moisture content equal to or greater than 30% held.

With the experiments being a success in producing self-heating elevated temperatures, it is obvious that the precise parameters necessary are still vague. Additional future study is needed to specify the parameters necessary for optimal composting. A better understanding of composting kinetics, energy values of compost components and mass transfer of water evaporation is needed.

REFERENCES

- APHA (1995) *Standard Methods for the Examination of Water and Wastewater*. Eds.: Eaton, A.D., Clesceri, L.S., and Greenberg, A.E., American Public Health Association, Washington, DC.
- ASTM D5338 (1992) Standard Test Method for Determining Aerobic Biodegradation of Plastic Materials Under Composting Conditions.
- Cook, A.M. (1987) Biodegradation of s-Triazine Xenobiotics. *FEMS Microbiol. Rev.* 46, 93.
- Hanif, M. (1995) Focus on Composting. *Hazardous Technical Information Services*, May/June, 7.
- Hogan, J.A., Miller, F.C., and Finstein, M.S. (1989) Physical Modeling of the Composting Ecosystem. *Applied Environ. Microbiol.*, May, 1082.
- Magalhaes, A.M.T. et al. (1993) Practical Simulation of Composting in the Laboratory. *Waste Management & Research*, 11, 143.
- Outwater, A.B. (1994) *Reuse of Sludge and Minor Wastewater Residuals*. Lewis Publishers, Ann Arbor, MI.
- Preston, K., Wade, R., Bergs, M., Ro, K.S., and Seiden, S. (1996) Bench Compost Implementation at Naval Surface Warfare Center Crane. Technical Report EL-96-, U.S. Army Engineer Waterways Experiment Station, Vicksburg, MS.
- Ro, K.S., Breitenbeck, G.A., Ghalambor, A. (1997) Composting Technology for Practical and Safe Remediation of Oil-Spill Residuals. Presented in the Oil Spill Research Symposium, May 2, Baton Rouge, LA.
- Ryan, J.R. et al. (1988) Biological Treatment of Hazardous Wastes. *Civil Engineering*, 58 (2), 65.
- Suler, D. (1979) Composting Hazardous Industrial Wastes. *Compost Science/Land Utilization*, July/August, 25.
- USAEC (1993) Windrow Composting Demonstration for Explosives-Contaminated Soils at the Unatilla Depot Activity Herminstron, Oregon. Contract No. DACA31-91-D-0079, Report No. CETHA-TS-CR-93043.
- USATHAMA (1988) Field Demonstration Composting of Explosive Contaminated Sediments at Louisiana Army Ammunition Plant (LAAP) Final Report. Contract No. DAAK-11-85-D-007, Report No. AMXTH-IR-TE-88242, Aberdeen Proving Grounds, MD.
- Wade, R., Ro, K.S., and Seiden, S. (1997) Oxymax Pilot-Scale System Composting and Toxicity of Explosive Contaminated Soils at Naval Surface Warfare Center Crane. Interim Report for Department of the Navy Southern Division, Naval Facilities Engineering Command, Charleston, SC.
- William, R.T. and Myler, C.A. (1990) Bioremediation Using Composting. *Biocycle*, November.

APPENDIX A: WATER TEMPERATURE PROFILE DATA

Trial 1 R-01-3.5A Water Temperature Profile

Ambient Temperature = 20.0°C

Time (hours)	Temperature (*C)	Time (hours)	Temperature (*C)	Time (hours)	Temperature (*C)	Time (hours)	Temperature (*C)
0.000	72.63	2.100	58.22	4.200	54.18	6.300	50.99
0.050	69.29	2.150	58.22	4.250	54.18	6.350	50.99
0.100	67.73	2.200	58.22	4.300	54.18	6.400	50.99
0.150	66.22	2.250	58.22	4.350	54.18	6.450	50.48
0.200	65.49	2.300	57.62	4.400	54.18	6.500	50.48
0.250	64.78	2.350	57.62	4.450	53.63	6.550	50.48
0.300	64.07	2.400	57.62	4.500	53.63	6.600	50.48
0.350	63.38	2.450	57.62	4.550	53.63	6.650	50.48
0.400	63.38	2.500	57.62	4.600	53.63	6.700	50.48
0.450	62.70	2.550	57.62	4.650	53.63	6.750	50.48
0.500	62.70	2.600	57.03	4.700	53.63	6.800	49.97
0.550	62.03	2.650	57.03	4.750	53.63	6.850	49.97
0.600	62.03	2.700	57.03	4.800	53.09	6.900	49.97
0.650	62.03	2.750	57.03	4.850	53.09	6.950	49.97
0.700	62.03	2.800	57.03	4.900	53.09	7.000	49.97
0.750	61.37	2.850	57.03	4.950	53.09	7.050	49.97
0.800	61.37	2.900	56.44	5.000	53.09	7.100	49.97
0.850	61.37	2.950	56.44	5.050	53.09	7.150	49.47
0.900	61.37	3.000	56.44	5.100	52.56	7.200	49.47
0.950	60.72	3.050	56.44	5.150	52.56	7.250	49.47
1.000	60.72	3.100	56.44	5.200	52.56	7.300	49.47
1.050	60.72	3.150	56.44	5.250	52.56	7.350	49.47
1.100	60.72	3.200	55.87	5.300	52.56	7.400	49.47
1.150	60.08	3.250	55.87	5.350	52.56	7.450	49.47
1.200	60.08	3.300	55.87	5.400	52.03	7.500	48.97
1.250	60.08	3.350	55.87	5.450	52.03	7.550	48.97
1.300	60.08	3.400	55.87	5.500	52.03	7.600	48.97
1.350	60.08	3.450	55.87	5.550	52.03	7.650	48.97
1.400	60.08	3.500	55.87	5.600	52.03	7.700	48.97
1.450	59.45	3.550	55.30	5.650	52.03	7.750	48.97
1.500	59.45	3.600	55.30	5.700	52.03	7.800	48.48
1.550	59.45	3.650	55.30	5.750	52.03	7.850	48.48
1.600	59.45	3.700	55.30	5.800	51.50	7.900	48.48
1.650	59.45	3.750	55.30	5.850	51.50	7.950	48.48
1.700	58.83	3.800	55.30	5.900	51.50	8.000	48.48
1.750	58.83	3.850	54.74	5.950	51.50	8.050	48.48
1.800	58.83	3.900	54.74	6.000	51.50	8.100	48.48
1.850	58.83	3.950	54.74	6.050	51.50	8.150	47.99
1.900	58.83	4.000	54.74	6.100	50.99	8.200	47.99
1.950	58.83	4.050	54.74	6.150	50.99	8.250	47.99
2.000	58.22	4.100	54.74	6.200	50.99	8.300	47.99
2.050	58.22	4.150	54.18	6.250	50.99	8.350	47.99

Time (hours)	Temperature (*C)	Time (hours)	Temperature (*C)	Time (hours)	Temperature (*C)
8.400	47.99	10.700	44.71	13.000	42.05
8.450	47.99	10.750	44.71	13.050	42.05
8.500	47.99	10.800	44.71	13.100	42.05
8.550	47.51	10.850	44.71	13.150	42.05
8.600	47.51	10.900	44.71	13.200	42.05
8.650	47.51	10.950	44.71	13.250	42.05
8.700	47.51	11.000	44.71	13.300	42.05
8.750	47.51	11.050	44.26	13.350	41.62
8.800	47.51	11.100	44.26	13.400	41.62
8.850	47.03	11.150	44.26	13.450	41.62
8.900	47.03	11.200	44.26	13.500	41.62
8.950	47.03	11.250	44.26	13.550	41.62
9.000	47.03	11.300	44.26	13.600	41.62
9.050	47.03	11.350	44.26	13.650	41.62
9.100	47.03	11.400	43.81	13.700	41.19
9.150	47.03	11.450	43.81	13.750	41.19
9.200	47.03	11.500	43.81	13.800	41.19
9.250	46.56	11.550	43.81	13.850	41.19
9.300	46.56	11.600	43.81	13.900	41.19
9.350	46.56	11.650	43.81	13.950	41.19
9.400	46.56	11.700	43.81	14.000	41.19
9.450	46.56	11.750	43.81	14.050	41.19
9.500	46.56	11.800	43.37	14.100	41.19
9.550	46.09	11.850	43.37	14.150	40.76
9.600	46.09	11.900	43.37	14.200	40.76
9.650	46.09	11.950	43.37	14.250	40.76
9.700	46.09	12.000	43.37	14.300	40.76
9.750	46.09	12.050	43.37	14.350	40.76
9.800	46.09	12.100	43.37	14.400	40.76
9.850	46.09	12.150	42.93	14.450	40.76
9.900	45.63	12.200	42.93	14.500	40.76
9.950	45.63	12.250	42.93	14.550	40.34
10.000	45.63	12.300	42.93	14.600	40.34
10.050	45.63	12.350	42.93	14.650	40.34
10.100	45.63	12.400	42.93	14.700	40.34
10.150	45.63	12.450	42.93	14.750	40.34
10.200	45.63	12.500	42.93	14.800	40.34
10.250	45.63	12.550	42.49	14.850	40.34
10.300	45.17	12.600	42.49	14.900	40.34
10.350	45.17	12.650	42.49	14.950	40.34
10.400	45.17	12.700	42.49		
10.450	45.17	12.750	42.49		
10.500	45.17	12.800	42.49		
10.550	45.17	12.850	42.49		
10.600	45.17	12.900	42.49		
10.650	44.71	12.950	42.05		

Trial 2 R-01-3.5A Water Temperature Profile

Ambient Temperature = 25.0°C

Time (hours)	Temperature (*C)	Time (hours)	Temperature (*C)	Time (hours)	Temperature (*C)	Time (hours)	Temperature (*C)
0.000	69.29	2.100	59.45	4.200	56.44	6.300	53.63
0.050	67.73	2.150	59.45	4.250	56.44	6.350	53.63
0.100	66.22	2.200	59.45	4.300	56.44	6.400	53.09
0.150	65.49	2.250	59.45	4.350	56.44	6.450	53.09
0.200	64.78	2.300	59.45	4.400	55.87	6.500	53.09
0.250	64.07	2.350	59.45	4.450	55.87	6.550	53.09
0.300	64.07	2.400	59.45	4.500	55.87	6.600	53.09
0.350	63.38	2.450	58.83	4.550	55.87	6.650	53.09
0.400	63.38	2.500	58.83	4.600	55.87	6.700	53.09
0.450	63.38	2.550	58.83	4.650	55.87	6.750	53.09
0.500	62.70	2.600	58.83	4.700	55.87	6.800	52.56
0.550	62.70	2.650	58.83	4.750	55.87	6.850	52.56
0.600	62.70	2.700	58.83	4.800	55.30	6.900	52.56
0.650	62.70	2.750	58.83	4.850	55.30	6.950	52.56
0.700	62.03	2.800	58.83	4.900	55.30	7.000	52.56
0.750	62.03	2.850	58.22	4.950	55.30	7.050	52.56
0.800	62.03	2.900	58.22	5.000	55.30	7.100	52.56
0.850	62.03	2.950	58.22	5.050	55.30	7.150	52.56
0.900	62.03	3.000	58.22	5.100	55.30	7.200	52.56
0.950	61.37	3.050	58.22	5.150	55.30	7.250	52.03
1.000	61.37	3.100	58.22	5.200	54.74	7.300	52.03
1.050	61.37	3.150	58.22	5.250	54.74	7.350	52.03
1.100	61.37	3.200	57.62	5.300	54.74	7.400	52.03
1.150	61.37	3.250	57.62	5.350	54.74	7.450	52.03
1.200	61.37	3.300	57.62	5.400	54.74	7.500	52.03
1.250	61.37	3.350	57.62	5.450	54.74	7.550	52.03
1.300	60.72	3.400	57.62	5.500	54.74	7.600	52.03
1.350	60.72	3.450	57.62	5.550	54.74	7.650	52.03
1.400	60.72	3.500	57.62	5.600	54.18	7.700	51.50
1.450	60.72	3.550	57.62	5.650	54.18	7.750	51.50
1.500	60.72	3.600	57.03	5.700	54.18	7.800	51.50
1.550	60.72	3.650	57.03	5.750	54.18	7.850	51.50
1.600	60.72	3.700	57.03	5.800	54.18	7.900	51.50
1.650	60.72	3.750	57.03	5.850	54.18	7.950	51.50
1.700	60.08	3.800	57.03	5.900	54.18	8.000	51.50
1.750	60.08	3.850	57.03	5.950	53.63	8.050	51.50
1.800	60.08	3.900	57.03	6.000	53.63	8.100	50.99
1.850	60.08	3.950	57.03	6.050	53.63	8.150	50.99
1.900	60.08	4.000	56.44	6.100	53.63	8.200	50.99
1.950	60.08	4.050	56.44	6.150	53.63	8.250	50.99
2.000	60.08	4.100	56.44	6.200	53.63	8.300	50.99
2.050	59.45	4.150	56.44	6.250	53.63	8.350	50.99

Time (hours)	Temperature (*C)	Time (hours)	Temperature (*C)	Time (hours)	Temperature (*C)
8.400	50.99	10.700	48.48	13.000	46.09
8.450	50.99	10.750	47.99	13.050	46.09
8.500	50.99	10.800	47.99	13.100	45.63
8.550	50.48	10.850	47.99	13.150	45.63
8.600	50.48	10.900	47.99	13.200	45.63
8.650	50.48	10.950	47.99	13.250	45.63
8.700	50.48	11.000	47.99	13.300	45.63
8.750	50.48	11.050	47.99	13.350	45.63
8.800	50.48	11.100	47.99	13.400	45.63
8.850	50.48	11.150	47.99	13.450	45.63
8.900	50.48	11.200	47.99	13.500	45.63
8.950	49.97	11.250	47.51	13.550	45.63
9.000	49.97	11.300	47.51	13.600	45.17
9.050	49.97	11.350	47.51	13.650	45.17
9.100	49.97	11.400	47.51	13.700	45.17
9.150	49.97	11.450	47.51	13.750	45.17
9.200	49.97	11.500	47.51	13.800	45.17
9.250	49.97	11.550	47.51	13.850	45.17
9.300	49.97	11.600	47.51	13.900	45.17
9.350	49.97	11.650	47.51	13.950	45.17
9.400	49.97	11.700	47.03	14.000	45.17
9.450	49.47	11.750	47.03	14.050	44.71
9.500	49.47	11.800	47.03	14.100	44.71
9.550	49.47	11.850	47.03	14.150	44.71
9.600	49.47	11.900	47.03	14.200	44.71
9.650	49.47	11.950	47.03	14.250	44.71
9.700	49.47	12.000	47.03	14.300	44.71
9.750	49.47	12.050	47.03	14.350	44.71
9.800	49.47	12.100	47.03	14.400	44.71
9.850	48.97	12.150	46.56	14.450	44.71
9.900	48.97	12.200	46.56	14.500	44.26
9.950	48.97	12.250	46.56	14.550	44.26
10.000	48.97	12.300	46.56	14.600	44.26
10.050	48.97	12.350	46.56	14.650	44.26
10.100	48.97	12.400	46.56	14.700	44.26
10.150	48.97	12.450	46.56	14.750	44.26
10.200	48.97	12.500	46.56	14.800	44.26
10.250	48.97	12.550	46.56	14.850	44.26
10.300	48.48	12.600	46.56	14.900	44.26
10.350	48.48	12.650	46.09	14.950	43.81
10.400	48.48	12.700	46.09		
10.450	48.48	12.750	46.09		
10.500	48.48	12.800	46.09		
10.550	48.48	12.850	46.09		
10.600	48.48	12.900	46.09		
10.650	48.48	12.950	46.09		

Trial 3 R-01-3.5A Water Temperature Profile

Ambient Temperature = 25.0°C

Time (hours)	Temperature (*C)	Time (hours)	Temperature (*C)	Time (hours)	Temperature (*C)	Time (hours)	Temperature (*C)
0.000	63.38	2.100	56.44	4.200	53.63	6.300	50.99
0.050	63.38	2.150	56.44	4.250	53.63	6.350	50.99
0.100	62.03	2.200	56.44	4.300	53.63	6.400	50.99
0.150	61.37	2.250	56.44	4.350	53.09	6.450	50.48
0.200	60.72	2.300	55.87	4.400	53.09	6.500	50.48
0.250	60.72	2.350	55.87	4.450	53.09	6.550	50.48
0.300	60.08	2.400	55.87	4.500	53.09	6.600	50.48
0.350	60.08	2.450	55.87	4.550	53.09	6.650	50.48
0.400	59.45	2.500	55.87	4.600	53.09	6.700	50.48
0.450	59.45	2.550	55.87	4.650	53.09	6.750	50.48
0.500	59.45	2.600	55.87	4.700	53.09	6.800	50.48
0.550	58.83	2.650	55.87	4.750	52.56	6.850	50.48
0.600	58.83	2.700	55.30	4.800	52.56	6.900	49.97
0.650	58.83	2.750	55.30	4.850	52.56	6.950	49.97
0.700	58.83	2.800	55.30	4.900	52.56	7.000	49.97
0.750	58.83	2.850	55.30	4.950	52.56	7.050	49.97
0.800	58.83	2.900	55.30	5.000	52.56	7.100	49.97
0.850	58.22	2.950	55.30	5.050	52.56	7.150	49.97
0.900	58.22	3.000	55.30	5.100	52.56	7.200	49.97
0.950	58.22	3.050	55.30	5.150	52.56	7.250	49.97
1.000	58.22	3.100	54.74	5.200	52.03	7.300	49.97
1.050	58.22	3.150	54.74	5.250	52.03	7.350	49.97
1.100	58.22	3.200	54.74	5.300	52.03	7.400	49.47
1.150	57.62	3.250	54.74	5.350	52.03	7.450	49.47
1.200	57.62	3.300	54.74	5.400	52.03	7.500	49.47
1.250	57.62	3.350	54.74	5.450	52.03	7.550	49.47
1.300	57.62	3.400	54.74	5.500	52.03	7.600	49.47
1.350	57.62	3.450	54.74	5.550	52.03	7.650	49.47
1.400	57.62	3.500	54.18	5.600	51.50	7.700	49.47
1.450	57.62	3.550	54.18	5.650	51.50	7.750	49.47
1.500	57.03	3.600	54.18	5.700	51.50	7.800	48.97
1.550	57.03	3.650	54.18	5.750	51.50	7.850	48.97
1.600	57.03	3.700	54.18	5.800	51.50	7.900	48.97
1.650	57.03	3.750	54.18	5.850	51.50	7.950	48.97
1.700	57.03	3.800	54.18	5.900	51.50	8.000	48.97
1.750	57.03	3.850	54.18	5.950	51.50	8.050	48.97
1.800	57.03	3.900	53.63	6.000	51.50	8.100	48.97
1.850	57.03	3.950	53.63	6.050	50.99	8.150	48.97
1.900	56.44	4.000	53.63	6.100	50.99	8.200	48.97
1.950	56.44	4.050	53.63	6.150	50.99	8.250	48.48
2.000	56.44	4.100	53.63	6.200	50.99	8.300	48.48
2.050	56.44	4.150	53.63	6.250	50.99	8.350	48.48

Time (hours)	Temperature (*C)	Time (hours)	Temperature (*C)	Time (hours)	Temperature (*C)
8.400	48.48	10.700	46.09	13.000	43.81
8.450	48.48	10.750	46.09	13.050	43.81
8.500	48.48	10.800	46.09	13.100	43.81
8.550	48.48	10.850	46.09	13.150	43.81
8.600	48.48	10.900	46.09	13.200	43.81
8.650	48.48	10.950	46.09	13.250	43.81
8.700	48.48	11.000	46.09	13.300	43.81
8.750	47.99	11.050	46.09	13.350	43.81
8.800	47.99	11.100	46.09	13.400	43.81
8.850	47.99	11.150	45.63	13.450	43.81
8.900	47.99	11.200	45.63	13.500	43.37
8.950	47.99	11.250	45.63	13.550	43.37
9.000	47.99	11.300	45.63	13.600	43.37
9.050	47.99	11.350	45.63	13.650	43.37
9.100	47.99	11.400	45.63	13.700	43.37
9.150	47.99	11.450	45.63	13.750	43.37
9.200	47.99	11.500	45.63	13.800	43.37
9.250	47.51	11.550	45.63	13.850	43.37
9.300	47.51	11.600	45.63	13.900	43.37
9.350	47.51	11.650	45.17	13.950	42.93
9.400	47.51	11.700	45.17	14.000	42.93
9.450	47.51	11.750	45.17	14.050	42.93
9.500	47.51	11.800	45.17	14.100	42.93
9.550	47.51	11.850	45.17	14.150	42.93
9.600	47.51	11.900	45.17	14.200	42.93
9.650	47.51	11.950	45.17	14.250	42.93
9.700	47.03	12.000	45.17	14.300	42.93
9.750	47.03	12.050	45.17	14.350	42.93
9.800	47.03	12.100	44.71	14.400	42.49
9.850	47.03	12.150	44.71	14.450	42.49
9.900	47.03	12.200	44.71	14.500	42.49
9.950	47.03	12.250	44.71	14.550	42.49
10.000	47.03	12.300	44.71	14.600	42.49
10.050	47.03	12.350	44.71	14.650	42.49
10.100	47.03	12.400	44.71	14.700	42.49
10.150	47.03	12.450	44.71	14.750	42.49
10.200	46.56	12.500	44.71	14.800	42.49
10.250	46.56	12.550	44.26	14.850	42.49
10.300	46.56	12.600	44.26	14.900	42.05
10.350	46.56	12.650	44.26	14.950	42.05
10.400	46.56	12.700	44.26		
10.450	46.56	12.750	44.26		
10.500	46.56	12.800	44.26		
10.550	46.56	12.850	44.26		
10.600	46.56	12.900	44.26		
10.650	46.56	12.950	44.26		

Trial 1 R-01-3.5B Water Temperature Profile

Ambient Temperature = 19.0°C

Time (hours)	Temperature (*C)	Time (hours)	Temperature (*C)	Time (hours)	Temperature (*C)	Time (hours)	Temperature (*C)
0.000	16.98	2.100	76.29	4.200	74.42	6.300	71.77
0.050	90.17	2.150	76.29	4.250	73.51	6.350	71.77
0.100	88.80	2.200	76.29	4.300	74.42	6.400	71.77
0.150	87.47	2.250	76.29	4.350	73.51	6.450	71.77
0.200	86.19	2.300	76.29	4.400	73.51	6.500	71.77
0.250	86.19	2.350	76.29	4.450	73.51	6.550	71.77
0.300	84.94	2.400	76.29	4.500	73.51	6.600	71.77
0.350	84.94	2.450	76.29	4.550	73.51	6.650	71.77
0.400	83.74	2.500	76.29	4.600	73.51	6.700	71.77
0.450	83.74	2.550	76.29	4.650	73.51	6.750	71.77
0.500	82.57	2.600	76.29	4.700	73.51	6.800	71.77
0.550	82.57	2.650	76.29	4.750	73.51	6.850	71.77
0.600	82.57	2.700	75.34	4.800	73.51	6.900	71.77
0.650	81.44	2.750	75.34	4.850	73.51	6.950	71.77
0.700	81.44	2.800	75.34	4.900	73.51	7.000	71.77
0.750	81.44	2.850	75.34	4.950	73.51	7.050	71.77
0.800	80.34	2.900	75.34	5.000	73.51	7.100	71.77
0.850	80.34	2.950	75.34	5.050	73.51	7.150	71.77
0.900	80.34	3.000	75.34	5.100	73.51	7.200	70.93
0.950	80.34	3.050	75.34	5.150	72.63	7.250	71.77
1.000	79.29	3.100	75.34	5.200	73.51	7.300	70.93
1.050	79.29	3.150	75.34	5.250	72.63	7.350	70.93
1.100	79.29	3.200	75.34	5.300	72.63	7.400	70.93
1.150	79.29	3.250	75.34	5.350	72.63	7.450	70.93
1.200	79.29	3.300	75.34	5.400	72.63	7.500	70.93
1.250	78.27	3.350	75.34	5.450	72.63	7.550	70.93
1.300	78.27	3.400	74.42	5.500	72.63	7.600	70.93
1.350	78.27	3.450	74.42	5.550	72.63	7.650	70.93
1.400	78.27	3.500	74.42	5.600	72.63	7.700	70.93
1.450	78.27	3.550	74.42	5.650	72.63	7.750	70.93
1.500	78.27	3.600	74.42	5.700	72.63	7.800	70.93
1.550	78.27	3.650	74.42	5.750	72.63	7.850	70.93
1.600	78.27	3.700	74.42	5.800	72.63	7.900	70.93
1.650	77.27	3.750	74.42	5.850	72.63	7.950	70.93
1.700	77.27	3.800	74.42	5.900	72.63	8.000	70.93
1.750	77.27	3.850	74.42	5.950	72.63	8.050	70.93
1.800	77.27	3.900	74.42	6.000	72.63	8.100	70.93
1.850	77.27	3.950	74.42	6.050	72.63	8.150	70.93
1.900	77.27	4.000	74.42	6.100	72.63	8.200	70.93
1.950	77.27	4.050	74.42	6.150	72.63	8.250	70.93
2.000	77.27	4.100	74.42	6.200	72.63	8.300	70.10
2.050	77.27	4.150	74.42	6.250	71.77	8.350	70.10

Time (hours)	Temperature (*C)	Time (hours)	Temperature (*C)	Time (hours)	Temperature (*C)
8.400	70.10	10.700	68.50	13.000	66.97
8.450	70.10	10.750	68.50	13.050	66.97
8.500	70.10	10.800	68.50	13.100	66.97
8.550	70.10	10.850	68.50	13.150	66.97
8.600	70.10	10.900	68.50	13.200	66.97
8.650	70.10	10.950	68.50	13.250	66.22
8.700	70.10	11.000	68.50	13.300	66.97
8.750	70.10	11.050	68.50	13.350	66.22
8.800	70.10	11.100	68.50	13.400	66.22
8.850	70.10	11.150	68.50	13.450	66.22
8.900	70.10	11.200	68.50	13.500	66.22
8.950	70.10	11.250	67.73	13.550	66.22
9.000	70.10	11.300	68.50	13.600	66.22
9.050	70.10	11.350	67.73	13.650	66.22
9.100	70.10	11.400	67.73	13.700	66.22
9.150	70.10	11.450	67.73	13.750	66.22
9.200	70.10	11.500	67.73	13.800	66.22
9.250	70.10	11.550	67.73	13.850	66.22
9.300	70.10	11.600	67.73	13.900	66.22
9.350	69.29	11.650	67.73	13.950	66.22
9.400	69.29	11.700	67.73	14.000	66.22
9.450	69.29	11.750	67.73	14.050	66.22
9.500	69.29	11.800	67.73	14.100	66.22
9.550	69.29	11.850	67.73	14.150	66.22
9.600	69.29	11.900	67.73	14.200	66.22
9.650	69.29	11.950	67.73	14.250	66.22
9.700	69.29	12.000	67.73	14.300	66.22
9.750	69.29	12.050	67.73	14.350	65.49
9.800	69.29	12.100	67.73	14.400	65.49
9.850	69.29	12.150	67.73	14.450	65.49
9.900	69.29	12.200	67.73	14.500	65.49
9.950	69.29	12.250	66.97	14.550	65.49
10.000	69.29	12.300	66.97	14.600	65.49
10.050	69.29	12.350	66.97	14.650	65.49
10.100	69.29	12.400	66.97	14.700	65.49
10.150	69.29	12.450	66.97	14.750	65.49
10.200	69.29	12.500	66.97	14.800	65.49
10.250	68.50	12.550	66.97	14.850	65.49
10.300	69.29	12.600	66.97	14.900	65.49
10.350	69.29	12.650	66.97	14.950	65.49
10.400	68.50	12.700	66.97		
10.450	68.50	12.750	66.97		
10.500	68.50	12.800	66.97		
10.550	68.50	12.850	66.97		
10.600	68.50	12.900	66.97		
10.650	68.50	12.950	66.97		

Trial 2 R-01-3.5B Water Temperature Profile

Ambient Temperature = 24.0°C

Time (hours)	Temperature (*C)	Time (hours)	Temperature (*C)	Time (hours)	Temperature (*C)	Time (hours)	Temperature (*C)
0.000	22.23	2.100	52.03	4.200	49.47	6.300	47.03
0.050	60.08	2.150	52.03	4.250	49.47	6.350	47.03
0.100	58.22	2.200	52.03	4.300	49.47	6.400	47.03
0.150	57.62	2.250	52.03	4.350	49.47	6.450	47.03
0.200	57.03	2.300	52.03	4.400	48.97	6.500	46.56
0.250	56.44	2.350	52.03	4.450	48.97	6.550	46.56
0.300	56.44	2.400	52.03	4.500	48.97	6.600	46.56
0.350	55.87	2.450	51.50	4.550	48.97	6.650	46.56
0.400	55.30	2.500	51.50	4.600	48.97	6.700	46.56
0.450	55.30	2.550	51.50	4.650	48.97	6.750	46.56
0.500	55.30	2.600	51.50	4.700	48.97	6.800	46.56
0.550	54.74	2.650	51.50	4.750	48.97	6.850	46.56
0.600	54.74	2.700	51.50	4.800	48.48	6.900	46.09
0.650	54.74	2.750	51.50	4.850	48.48	6.950	46.09
0.700	54.74	2.800	51.50	4.900	48.48	7.000	46.09
0.750	54.18	2.850	50.99	4.950	48.48	7.050	46.09
0.800	54.18	2.900	50.99	5.000	48.48	7.100	46.09
0.850	54.18	2.950	50.99	5.050	48.48	7.150	46.09
0.900	54.18	3.000	50.99	5.100	48.48	7.200	46.09
0.950	54.18	3.050	50.99	5.150	48.48	7.250	46.09
1.000	53.63	3.100	50.99	5.200	47.99	7.300	45.63
1.050	53.63	3.150	50.99	5.250	47.99	7.350	45.63
1.100	53.63	3.200	50.99	5.300	47.99	7.400	45.63
1.150	53.63	3.250	50.48	5.350	47.99	7.450	45.63
1.200	53.63	3.300	50.48	5.400	47.99	7.500	45.63
1.250	53.63	3.350	50.48	5.450	47.99	7.550	45.63
1.300	53.63	3.400	50.48	5.500	47.99	7.600	45.63
1.350	53.09	3.450	50.48	5.550	47.99	7.650	45.63
1.400	53.09	3.500	50.48	5.600	47.99	7.700	45.63
1.450	53.09	3.550	50.48	5.650	47.51	7.750	45.17
1.500	53.09	3.600	49.97	5.700	47.51	7.800	45.17
1.550	53.09	3.650	49.97	5.750	47.51	7.850	45.17
1.600	53.09	3.700	49.97	5.800	47.51	7.900	45.17
1.650	53.09	3.750	49.97	5.850	47.51	7.950	45.17
1.700	52.56	3.800	49.97	5.900	47.51	8.000	45.17
1.750	52.56	3.850	49.97	5.950	47.51	8.050	45.17
1.800	52.56	3.900	49.97	6.000	47.51	8.100	45.17
1.850	52.56	3.950	49.97	6.050	47.03	8.150	44.71
1.900	52.56	4.000	49.97	6.100	47.03	8.200	44.71
1.950	52.56	4.050	49.47	6.150	47.03	8.250	44.71
2.000	52.56	4.100	49.47	6.200	47.03	8.300	44.71
2.050	52.56	4.150	49.47	6.250	47.03	8.350	44.71

Time (hours)	Temperature (*C)	Time (hours)	Temperature (*C)	Time (hours)	Temperature (*C)
8.400	44.71	10.700	42.49	13.000	40.34
8.450	44.71	10.750	42.49	13.050	40.34
8.500	44.71	10.800	42.49	13.100	40.34
8.550	44.71	10.850	42.05	13.150	40.34
8.600	44.26	10.900	42.05	13.200	40.34
8.650	44.26	10.950	42.05	13.250	40.34
8.700	44.26	11.000	42.05	13.300	40.34
8.750	44.26	11.050	42.05	13.350	39.92
8.800	44.26	11.100	42.05	13.400	39.92
8.850	44.26	11.150	42.05	13.450	39.92
8.900	44.26	11.200	42.05	13.500	39.92
8.950	44.26	11.250	42.05	13.550	39.92
9.000	44.26	11.300	41.62	13.600	39.92
9.050	43.81	11.350	41.62	13.650	39.92
9.100	43.81	11.400	41.62	13.700	39.92
9.150	43.81	11.450	41.62	13.750	39.92
9.200	43.81	11.500	41.62	13.800	39.92
9.250	43.81	11.550	41.62	13.850	39.92
9.300	43.81	11.600	41.62	13.900	39.92
9.350	43.81	11.650	41.62	13.950	39.50
9.400	43.81	11.700	41.62	14.000	39.50
9.450	43.81	11.750	41.62	14.050	39.50
9.500	43.37	11.800	41.19	14.100	39.50
9.550	43.37	11.850	41.19	14.150	39.50
9.600	43.37	11.900	41.19	14.200	39.50
9.650	43.37	11.950	41.19	14.250	39.50
9.700	43.37	12.000	41.19	14.300	39.50
9.750	43.37	12.050	41.19	14.350	39.50
9.800	43.37	12.100	41.19	14.400	39.50
9.850	43.37	12.150	41.19	14.450	39.50
9.900	43.37	12.200	41.19	14.500	39.08
9.950	42.93	12.250	41.19	14.550	39.08
10.000	42.93	12.300	40.76	14.600	39.08
10.050	42.93	12.350	40.76	14.650	39.08
10.100	42.93	12.400	40.76	14.700	39.08
10.150	42.93	12.450	40.76	14.750	39.08
10.200	42.93	12.500	40.76	14.800	39.08
10.250	42.93	12.550	40.76	14.850	39.08
10.300	42.93	12.600	40.76	14.900	39.08
10.350	42.93	12.650	40.76	14.950	39.08
10.400	42.49	12.700	40.76		
10.450	42.49	12.750	40.76		
10.500	42.49	12.800	40.76		
10.550	42.49	12.850	40.34		
10.600	42.49	12.900	40.34		
10.650	42.49	12.950	40.34		

Trial 3 R-01-3.5B Water Temperature Profile

Ambient Temperature = 20.0°C

Time (hours)	Temperature (*C)	Time (hours)	Temperature (*C)	Time (hours)	Temperature (*C)	Time (hours)	Temperature (*C)
0.000	19.43	2.100	53.63	4.200	50.48	6.300	47.51
0.050	62.70	2.150	53.63	4.250	50.48	6.350	47.51
0.100	60.72	2.200	53.63	4.300	50.48	6.400	47.51
0.150	60.08	2.250	53.63	4.350	49.97	6.450	47.03
0.200	59.45	2.300	53.63	4.400	49.97	6.500	47.03
0.250	58.83	2.350	53.09	4.450	49.97	6.550	47.03
0.300	58.22	2.400	53.09	4.500	49.97	6.600	47.03
0.350	58.22	2.450	53.09	4.550	49.97	6.650	47.03
0.400	57.62	2.500	53.09	4.600	49.97	6.700	47.03
0.450	57.62	2.550	53.09	4.650	49.97	6.750	47.03
0.500	57.03	2.600	53.09	4.700	49.47	6.800	46.56
0.550	57.03	2.650	52.56	4.750	49.47	6.850	46.56
0.600	57.03	2.700	52.56	4.800	49.47	6.900	46.56
0.650	56.44	2.750	52.56	4.850	49.47	6.950	46.56
0.700	56.44	2.800	52.56	4.900	49.47	7.000	46.56
0.750	56.44	2.850	52.56	4.950	49.47	7.050	46.56
0.800	56.44	2.900	52.56	5.000	48.97	7.100	46.56
0.850	56.44	2.950	52.56	5.050	48.97	7.150	46.09
0.900	55.87	3.000	52.03	5.100	48.97	7.200	46.09
0.950	55.87	3.050	52.03	5.150	48.97	7.250	46.09
1.000	55.87	3.100	52.03	5.200	48.97	7.300	46.09
1.050	55.87	3.150	52.03	5.250	48.97	7.350	46.09
1.100	55.87	3.200	52.03	5.300	48.97	7.400	46.09
1.150	55.30	3.250	52.03	5.350	48.48	7.450	46.09
1.200	55.30	3.300	52.03	5.400	48.48	7.500	45.63
1.250	55.30	3.350	51.50	5.450	48.48	7.550	45.63
1.300	55.30	3.400	51.50	5.500	48.48	7.600	45.63
1.350	55.30	3.450	51.50	5.550	48.48	7.650	45.63
1.400	55.30	3.500	51.50	5.600	48.48	7.700	45.63
1.450	54.74	3.550	51.50	5.650	48.48	7.750	45.63
1.500	54.74	3.600	51.50	5.700	48.48	7.800	45.63
1.550	54.74	3.650	50.99	5.750	47.99	7.850	45.63
1.600	54.74	3.700	50.99	5.800	47.99	7.900	45.17
1.650	54.74	3.750	50.99	5.850	47.99	7.950	45.17
1.700	54.74	3.800	50.99	5.900	47.99	8.000	45.17
1.750	54.18	3.850	50.99	5.950	47.99	8.050	45.17
1.800	54.18	3.900	50.99	6.000	47.99	8.100	45.17
1.850	54.18	3.950	50.99	6.050	47.99	8.150	45.17
1.900	54.18	4.000	50.48	6.100	47.51	8.200	45.17
1.950	54.18	4.050	50.48	6.150	47.51	8.250	44.71
2.000	53.63	4.100	50.48	6.200	47.51	8.300	44.71
2.050	53.63	4.150	50.48	6.250	47.51	8.350	44.71

Time (hours)	Temperature (*C)	Time (hours)	Temperature (*C)	Time (hours)	Temperature (*C)
8.400	44.71	10.700	42.05	13.000	39.92
8.450	44.71	10.750	42.05	13.050	39.92
8.500	44.71	10.800	42.05	13.100	39.92
8.550	44.71	10.850	42.05	13.150	39.92
8.600	44.71	10.900	42.05	13.200	39.50
8.650	44.26	10.950	42.05	13.250	39.50
8.700	44.26	11.000	41.62	13.300	39.50
8.750	44.26	11.050	41.62	13.350	39.50
8.800	44.26	11.100	41.62	13.400	39.50
8.850	44.26	11.150	41.62	13.450	39.50
8.900	44.26	11.200	41.62	13.500	39.50
8.950	44.26	11.250	41.62	13.550	39.50
9.000	43.81	11.300	41.62	13.600	39.50
9.050	43.81	11.350	41.62	13.650	39.08
9.100	43.81	11.400	41.19	13.700	39.08
9.150	43.81	11.450	41.19	13.750	39.08
9.200	43.81	11.500	41.19	13.800	39.08
9.250	43.81	11.550	41.19	13.850	39.08
9.300	43.81	11.600	41.19	13.900	39.08
9.350	43.81	11.650	41.19	13.950	39.08
9.400	43.37	11.700	41.19	14.000	38.67
9.450	43.37	11.750	41.19	14.050	38.67
9.500	43.37	11.800	41.19	14.100	38.67
9.550	43.37	11.850	40.76	14.150	38.26
9.600	43.37	11.900	40.76	14.200	37.85
9.650	43.37	11.950	40.76	14.250	-37.72
9.700	43.37	12.000	40.76	14.300	38.67
9.750	43.37	12.050	40.76	14.350	38.67
9.800	42.93	12.100	40.76	14.400	38.67
9.850	42.93	12.150	40.76	14.450	38.67
9.900	42.93	12.200	40.76	14.500	38.67
9.950	42.93	12.250	40.76	14.550	38.67
10.000	42.93	12.300	40.34	14.600	38.26
10.050	42.93	12.350	40.34	14.650	38.26
10.100	42.93	12.400	40.34	14.700	38.26
10.150	42.93	12.450	40.34	14.750	38.26
10.200	42.49	12.500	40.34	14.800	38.26
10.250	42.49	12.550	40.34	14.850	38.26
10.300	42.49	12.600	40.34	14.900	38.26
10.350	42.49	12.650	40.34	14.950	38.26
10.400	42.49	12.700	40.34		
10.450	42.49	12.750	39.92		
10.500	42.49	12.800	39.92		
10.550	42.49	12.850	39.92		
10.600	42.05	12.900	39.92		
10.650	42.05	12.950	39.92		

Trial 4 R-01-3.5B Water Temperature Profile

Ambient Temperature = 25.0°C

Time (hours)	Temperature (*C)	Time (hours)	Temperature (*C)	Time (hours)	Temperature (*C)	Time (hours)	Temperature (*C)
0.000	23.28	2.100	71.77	4.200	66.22	6.300	62.03
0.050	84.94	2.150	71.77	4.250	66.22	6.350	62.03
0.100	82.57	2.200	70.93	4.300	66.22	6.400	61.37
0.150	81.44	2.250	70.93	4.350	66.22	6.450	61.37
0.200	80.34	2.300	70.93	4.400	66.22	6.500	61.37
0.250	79.29	2.350	70.93	4.450	65.49	6.550	61.37
0.300	78.27	2.400	70.93	4.500	65.49	6.600	61.37
0.350	78.27	2.450	70.93	4.550	65.49	6.650	61.37
0.400	77.27	2.500	70.10	4.600	65.49	6.700	61.37
0.450	77.27	2.550	70.10	4.650	65.49	6.750	60.72
0.500	76.29	2.600	70.10	4.700	65.49	6.800	60.72
0.550	76.29	2.650	70.10	4.750	65.49	6.850	60.72
0.600	76.29	2.700	70.10	4.800	64.78	6.900	60.72
0.650	76.29	2.750	70.10	4.850	64.78	6.950	60.72
0.700	75.34	2.800	70.10	4.900	64.78	7.000	60.72
0.750	75.34	2.850	69.29	4.950	64.78	7.050	60.08
0.800	75.34	2.900	69.29	5.000	64.78	7.100	60.08
0.850	75.34	2.950	69.29	5.050	64.78	7.150	60.08
0.900	75.34	3.000	69.29	5.100	64.07	7.200	60.08
0.950	74.42	3.050	69.29	5.150	64.07	7.250	60.08
1.000	74.42	3.100	69.29	5.200	64.07	7.300	60.08
1.050	74.42	3.150	68.50	5.250	64.07	7.350	60.08
1.100	74.42	3.200	68.50	5.300	64.07	7.400	59.45
1.150	74.42	3.250	68.50	5.350	64.07	7.450	59.45
1.200	74.42	3.300	68.50	5.400	63.38	7.500	59.45
1.250	73.51	3.350	68.50	5.450	63.38	7.550	59.45
1.300	73.51	3.400	68.50	5.500	63.38	7.600	59.45
1.350	73.51	3.450	67.73	5.550	63.38	7.650	59.45
1.400	73.51	3.500	67.73	5.600	63.38	7.700	59.45
1.450	73.51	3.550	67.73	5.650	63.38	7.750	58.83
1.500	73.51	3.600	67.73	5.700	63.38	7.800	58.83
1.550	72.63	3.650	67.73	5.750	62.70	7.850	58.83
1.600	72.63	3.700	67.73	5.800	62.70	7.900	58.83
1.650	72.63	3.750	67.73	5.850	62.70	7.950	58.83
1.700	72.63	3.800	66.97	5.900	62.70	8.000	58.83
1.750	72.63	3.850	66.97	5.950	62.70	8.050	58.83
1.800	72.63	3.900	66.97	6.000	62.70	8.100	58.22
1.850	71.77	3.950	66.97	6.050	62.03	8.150	58.22
1.900	71.77	4.000	66.97	6.100	62.03	8.200	58.22
1.950	71.77	4.050	66.97	6.150	62.03	8.250	58.22
2.000	71.77	4.100	66.97	6.200	62.03	8.300	58.22
2.050	71.77	4.150	66.22	6.250	62.03	8.350	58.22

Time (hours)	Temperature (*C)	Time (hours)	Temperature (*C)	Time (hours)	Temperature (*C)
8.400	58.22	10.700	54.18	13.000	50.99
8.450	57.62	10.750	54.18	13.050	50.99
8.500	57.62	10.800	54.18	13.100	50.99
8.550	57.62	10.850	54.18	13.150	50.48
8.600	57.62	10.900	54.18	13.200	50.48
8.650	57.62	10.950	53.63	13.250	50.48
8.700	57.62	11.000	53.63	13.300	50.48
8.750	57.62	11.050	53.63	13.350	50.48
8.800	57.03	11.100	53.63	13.400	50.48
8.850	57.03	11.150	53.63	13.450	50.48
8.900	57.03	11.200	53.63	13.500	49.97
8.950	57.03	11.250	53.63	13.550	49.97
9.000	57.03	11.300	53.09	13.600	49.97
9.050	57.03	11.350	53.09	13.650	49.97
9.100	57.03	11.400	53.09	13.700	49.97
9.150	56.44	11.450	53.09	13.750	49.97
9.200	56.44	11.500	53.09	13.800	49.97
9.250	56.44	11.550	53.09	13.850	49.97
9.300	56.44	11.600	53.09	13.900	49.47
9.350	56.44	11.650	53.09	13.950	49.47
9.400	56.44	11.700	52.56	14.000	49.47
9.450	56.44	11.750	52.56	14.050	49.47
9.500	56.44	11.800	52.56	14.100	49.47
9.550	55.87	11.850	52.56	14.150	49.47
9.600	55.87	11.900	52.56	14.200	49.47
9.650	55.87	11.950	52.56	14.250	48.97
9.700	55.87	12.000	52.56	14.300	48.97
9.750	55.87	12.050	52.03	14.350	48.97
9.800	55.87	12.100	52.03	14.400	48.97
9.850	55.87	12.150	52.03	14.450	48.97
9.900	55.30	12.200	52.03	14.500	48.97
9.950	55.30	12.250	52.03	14.550	48.97
10.000	55.30	12.300	52.03	14.600	48.48
10.050	55.30	12.350	52.03	14.650	48.48
10.100	55.30	12.400	52.03	14.700	48.48
10.150	55.30	12.450	51.50	14.750	48.48
10.200	55.30	12.500	51.50	14.800	48.48
10.250	54.74	12.550	51.50	14.850	48.48
10.300	54.74	12.600	51.50	14.900	48.48
10.350	54.74	12.650	51.50	14.950	48.48
10.400	54.74	12.700	51.50		
10.450	54.74	12.750	51.50		
10.500	54.74	12.800	50.99		
10.550	54.74	12.850	50.99		
10.600	54.18	12.900	50.99		
10.650	54.18	12.950	50.99		

Trial 1 R-01-6.5A Water Temperature Profile

Ambient Temperature = 25.0°C

Time (hours)	Temperature (*C)	Time (hours)	Temperature (*C)	Time (hours)	Temperature (*C)	Time (hours)	Temperature (*C)
0.000	22.68	3.360	53.19	6.720	46.65	10.080	41.28
0.080	64.18	3.440	53.19	6.800	46.65	10.160	40.85
0.160	62.13	3.520	53.19	6.880	46.19	10.240	40.85
0.240	61.47	3.600	52.65	6.960	46.19	10.320	40.85
0.320	60.82	3.680	52.65	7.040	46.19	10.400	40.85
0.400	60.82	3.760	52.65	7.120	45.73	10.480	40.43
0.480	60.18	3.840	52.13	7.200	45.73	10.560	40.43
0.560	60.18	3.920	52.13	7.280	45.73	10.640	40.43
0.640	60.18	4.000	52.13	7.360	45.73	10.720	40.43
0.720	59.55	4.080	51.60	7.440	45.27	10.800	40.01
0.800	59.55	4.160	51.60	7.520	45.27	10.880	40.01
0.880	58.93	4.240	51.60	7.600	45.27	10.960	40.01
0.960	58.93	4.320	51.08	7.680	44.81	11.040	40.01
1.040	58.93	4.400	51.08	7.760	44.81	11.120	39.59
1.120	58.32	4.480	51.08	7.840	44.81	11.200	39.59
1.200	58.32	4.560	50.57	7.920	44.36	11.280	39.59
1.280	58.32	4.640	50.57	8.000	44.36	11.360	39.59
1.360	58.32	4.720	50.57	8.080	44.36	11.440	39.18
1.440	57.72	4.800	50.06	8.160	43.91	11.520	39.18
1.520	57.72	4.880	50.06	8.240	43.91	11.600	39.18
1.600	57.72	4.960	50.06	8.320	43.91	11.680	39.18
1.680	57.13	5.040	49.56	8.400	43.46	11.760	39.18
1.760	57.13	5.120	49.56	8.480	43.46	11.840	38.77
1.840	56.54	5.200	49.56	8.560	43.46	11.920	38.77
1.920	56.54	5.280	49.56	8.640	43.46	12.000	38.77
2.000	56.54	5.360	49.07	8.720	43.02	12.080	38.77
2.080	56.54	5.440	49.07	8.800	43.02	12.160	38.36
2.160	55.97	5.520	49.07	8.880	43.02	12.240	38.36
2.240	55.97	5.600	48.57	8.960	42.58	12.320	38.36
2.320	55.97	5.680	48.57	9.040	42.58	12.400	38.36
2.400	55.39	5.760	48.57	9.120	42.58	12.480	38.36
2.480	55.39	5.840	48.09	9.200	42.58	12.560	37.95
2.560	55.39	5.920	48.09	9.280	42.14	12.640	37.95
2.640	54.83	6.000	48.09	9.360	42.14	12.720	37.95
2.720	54.83	6.080	47.60	9.440	42.14	12.800	37.95
2.800	54.83	6.160	47.60	9.520	42.14	12.880	37.54
2.880	54.28	6.240	47.60	9.600	41.71	12.960	37.54
2.960	54.28	6.320	47.60	9.680	41.71	13.040	37.54
3.040	54.28	6.400	47.13	9.760	41.71	13.120	37.54
3.120	53.73	6.480	47.13	9.840	41.28	13.200	37.54
3.200	53.73	6.560	47.13	9.920	41.28	13.280	37.14
3.280	53.73	6.640	46.65	10.000	41.28	13.360	37.14

Time (hours)	Temperature (*C)	Time (hours)	Temperature (*C)	Time (hours)	Temperature (*C)
13.440	37.14	17.120	34.01	20.800	31.35
13.520	37.14	17.200	34.01	20.880	31.35
13.600	37.14	17.280	34.01	20.960	31.35
13.680	37.14	17.360	34.01	21.040	31.35
13.760	36.74	17.440	34.01	21.120	31.35
13.840	36.74	17.520	34.01	21.200	30.98
13.920	36.74	17.600	33.62	21.280	30.98
14.000	36.74	17.680	33.62	21.360	30.98
14.080	36.74	17.760	33.62	21.440	30.98
14.160	36.74	17.840	33.62	21.520	30.98
14.240	36.35	17.920	33.62	21.600	30.98
14.320	36.35	18.000	33.62	21.680	30.98
14.400	36.35	18.080	33.62	21.760	30.98
14.480	36.35	18.160	33.24	21.840	30.98
14.560	36.35	18.240	33.24	21.920	30.98
14.640	35.96	18.320	33.24	22.000	30.61
14.720	35.96	18.400	33.24	22.080	30.61
14.800	35.96	18.480	33.24	22.160	30.61
14.880	35.96	18.560	33.24	22.240	30.61
14.960	35.96	18.640	33.24	22.320	30.61
15.040	35.96	18.720	32.86	22.400	30.61
15.120	35.56	18.800	32.86	22.480	30.61
15.200	35.56	18.880	32.86	22.560	30.61
15.280	35.56	18.960	32.86	22.640	30.61
15.360	35.56	19.040	32.86	22.720	30.61
15.440	35.56	19.120	32.86	22.800	30.23
15.520	35.56	19.200	32.48	22.880	30.23
15.600	35.17	19.280	32.48	22.960	30.23
15.680	35.17	19.360	32.48	23.040	30.23
15.760	35.17	19.440	32.48	23.120	30.23
15.840	35.17	19.520	32.48	23.200	30.23
15.920	35.17	19.600	32.48	23.280	30.23
16.000	35.17	19.680	32.10	23.360	30.23
16.080	34.78	19.760	32.10	23.440	30.23
16.160	34.78	19.840	32.10	23.520	30.23
16.240	34.78	19.920	32.10	23.600	30.23
16.320	34.78	20.000	32.10	23.680	30.23
16.400	34.78	20.080	32.10	23.760	29.87
16.480	34.39	20.160	31.73	23.840	29.87
16.560	34.39	20.240	31.73	23.920	29.87
16.640	34.39	20.320	31.73		
16.720	34.39	20.400	31.73		
16.800	34.39	20.480	31.73		
16.880	34.39	20.560	31.73		
16.960	34.39	20.640	31.35		
17.040	34.01	20.720	31.35		

Trial 2 R-01-6.5A Water Temperature Profile

Ambient Temperature = 25.0°C

Time (hours)	Temperature (*C)	Time (hours)	Temperature (*C)	Time (hours)	Temperature (*C)	Time (hours)	Temperature (*C)
0.000	22.68	3.360	48.09	6.720	40.85	10.080	35.56
0.080	58.32	3.440	48.09	6.800	40.43	10.160	35.56
0.160	57.72	3.520	48.09	6.880	40.01	10.240	35.56
0.240	56.54	3.600	47.60	6.960	40.01	10.320	35.17
0.320	55.97	3.680	47.60	7.040	39.59	10.400	35.17
0.400	55.97	3.760	47.60	7.120	39.59	10.480	35.17
0.480	55.39	3.840	47.13	7.200	39.18	10.560	35.17
0.560	55.39	3.920	47.13	7.280	39.18	10.640	35.17
0.640	54.83	4.000	46.65	7.360	39.18	10.720	35.17
0.720	54.83	4.080	46.65	7.440	38.77	10.800	34.78
0.800	54.28	4.160	46.65	7.520	38.77	10.880	34.78
0.880	54.28	4.240	46.19	7.600	38.77	10.960	34.78
0.960	54.28	4.320	46.19	7.680	38.36	11.040	34.78
1.040	53.73	4.400	45.73	7.760	38.36	11.120	34.78
1.120	53.73	4.480	45.73	7.840	38.36	11.200	34.78
1.200	53.73	4.560	45.27	7.920	37.95	11.280	34.39
1.280	53.19	4.640	45.27	8.000	37.95	11.360	34.39
1.360	53.19	4.720	45.27	8.080	37.95	11.440	34.39
1.440	53.19	4.800	44.81	8.160	37.54	11.520	34.39
1.520	52.65	4.880	44.81	8.240	37.54	11.600	34.01
1.600	52.65	4.960	44.81	8.320	37.54	11.680	34.01
1.680	52.65	5.040	44.36	8.400	37.54	11.760	34.01
1.760	52.13	5.120	44.36	8.480	37.14	11.840	34.01
1.840	51.60	5.200	43.91	8.560	37.14	11.920	33.62
1.920	51.60	5.280	43.91	8.640	37.14	12.000	33.62
2.000	51.08	5.360	43.91	8.720	37.14	12.080	33.62
2.080	51.08	5.440	43.46	8.800	36.74	12.160	33.24
2.160	50.57	5.520	43.46	8.880	36.74	12.240	33.24
2.240	50.57	5.600	43.46	8.960	36.74	12.320	32.86
2.320	50.06	5.680	43.02	9.040	36.74	12.400	32.86
2.400	50.06	5.760	43.02	9.120	36.35	12.480	32.86
2.480	50.06	5.840	42.58	9.200	36.35	12.560	32.48
2.560	49.56	5.920	42.58	9.280	36.35	12.640	32.48
2.640	49.56	6.000	42.58	9.360	36.35	12.720	32.10
2.720	49.56	6.080	42.14	9.440	35.96	12.800	32.10
2.800	49.56	6.160	42.14	9.520	35.96	12.880	32.10
2.880	49.07	6.240	42.14	9.600	35.96	12.960	32.10
2.960	49.07	6.320	41.71	9.680	35.96	13.040	31.73
3.040	49.07	6.400	41.71	9.760	35.96	13.120	31.73
3.120	48.57	6.480	41.28	9.840	35.56	13.200	31.73
3.200	48.57	6.560	41.28	9.920	35.56	13.280	31.73
3.280	48.09	6.640	40.85	10.000	35.56	13.360	31.73

Time (hours)	Temperature (*C)	Time (hours)	Temperature (*C)	Time (hours)	Temperature (*C)
13.440	31.35	17.120	27.68	20.800	26.61
13.520	31.35	17.200	27.68	20.880	26.61
13.600	31.35	17.280	27.68	20.960	26.61
13.680	31.35	17.360	27.32	21.040	26.61
13.760	31.35	17.440	27.32	21.120	26.61
13.840	31.35	17.520	27.32	21.200	26.61
13.920	30.98	17.600	27.32	21.280	26.61
14.000	30.98	17.680	27.32	21.360	26.61
14.080	30.98	17.760	27.32	21.440	26.61
14.160	30.98	17.840	26.96	21.520	26.61
14.240	30.98	17.920	26.96	21.600	26.61
14.320	30.98	18.000	26.96	21.680	26.61
14.400	30.98	18.080	26.96	21.760	26.61
14.480	30.98	18.160	26.96	21.840	26.61
14.560	30.98	18.240	26.96	21.920	26.61
14.640	30.61	18.320	26.96	22.000	26.24
14.720	30.61	18.400	26.96	22.080	26.24
14.800	30.61	18.480	26.96	22.160	26.24
14.880	30.61	18.560	26.96	22.240	26.24
14.960	30.61	18.640	26.96	22.320	26.24
15.040	30.61	18.720	26.96	22.400	26.24
15.120	30.61	18.800	26.96	22.480	26.24
15.200	30.61	18.880	26.96	22.560	26.24
15.280	30.23	18.960	26.96	22.640	26.24
15.360	30.23	19.040	26.96	22.720	26.24
15.440	30.23	19.120	26.96	22.800	26.24
15.520	30.23	19.200	26.96	22.880	26.24
15.600	30.23	19.280	26.96	22.960	26.24
15.680	29.87	19.360	26.96	23.040	26.24
15.760	29.87	19.440	26.96	23.120	26.24
15.840	29.87	19.520	26.96	23.200	26.24
15.920	29.49	19.600	26.96	23.280	26.24
16.000	29.49	19.680	26.96	23.360	26.24
16.080	29.49	19.760	26.96	23.440	26.24
16.160	29.13	19.840	26.96	23.520	26.24
16.240	29.13	19.920	26.96	23.600	25.89
16.320	29.13	20.000	26.96	23.680	25.89
16.400	28.77	20.080	26.96	23.760	25.89
16.480	28.77	20.160	26.96	23.840	25.89
16.560	28.40	20.240	26.96	23.920	25.89
16.640	28.40	20.320	26.96		
16.720	28.40	20.400	26.96		
16.800	28.40	20.480	26.61		
16.880	28.04	20.560	26.61		
16.960	28.04	20.640	26.61		
17.040	28.04	20.720	26.61		

Trial 3 R-01-6.5A Water Temperature Profile

Ambient Temperature = 22.0°C

Time (hours)	Temperature (*C)	Time (hours)	Temperature (*C)	Time (hours)	Temperature (*C)	Time (hours)	Temperature (*C)
0.000	21.63	3.360	50.06	6.720	43.46	10.080	39.18
0.080	62.13	3.440	49.56	6.800	43.46	10.160	39.18
0.160	60.18	3.520	49.56	6.880	43.46	10.240	39.18
0.240	59.55	3.600	49.56	6.960	43.46	10.320	38.77
0.320	58.93	3.680	49.07	7.040	43.02	10.400	38.77
0.400	58.32	3.760	49.07	7.120	43.02	10.480	38.77
0.480	57.72	3.840	49.07	7.200	43.02	10.560	38.77
0.560	57.72	3.920	48.57	7.280	42.58	10.640	38.36
0.640	57.13	4.000	48.57	7.360	42.58	10.720	38.36
0.720	57.13	4.080	48.09	7.440	42.58	10.800	38.36
0.800	56.54	4.160	48.09	7.520	42.58	10.880	38.36
0.880	56.54	4.240	48.09	7.600	42.14	10.960	37.95
0.960	55.97	4.320	47.60	7.680	42.14	11.040	37.95
1.040	55.97	4.400	47.60	7.760	42.14	11.120	37.95
1.120	55.39	4.480	47.60	7.840	42.14	11.200	37.95
1.200	55.39	4.560	47.60	7.920	41.71	11.280	37.95
1.280	54.83	4.640	47.13	8.000	41.71	11.360	37.54
1.360	54.83	4.720	47.13	8.080	41.71	11.440	37.54
1.440	54.83	4.800	47.13	8.160	41.71	11.520	37.54
1.520	54.28	4.880	46.65	8.240	41.28	11.600	37.54
1.600	54.28	4.960	46.65	8.320	41.28	11.680	37.14
1.680	54.28	5.040	46.65	8.400	41.28	11.760	37.14
1.760	53.73	5.120	46.19	8.480	41.28	11.840	37.14
1.840	53.73	5.200	46.19	8.560	40.85	11.920	37.14
1.920	53.19	5.280	46.19	8.640	40.85	12.000	37.14
2.000	53.19	5.360	45.73	8.720	40.85	12.080	36.74
2.080	53.19	5.440	45.73	8.800	40.85	12.160	36.74
2.160	52.65	5.520	45.73	8.880	40.43	12.240	36.74
2.240	52.65	5.600	45.27	8.960	40.43	12.320	36.74
2.320	52.13	5.680	45.27	9.040	40.43	12.400	36.74
2.400	52.13	5.760	45.27	9.120	40.43	12.480	36.35
2.480	52.13	5.840	44.81	9.200	40.01	12.560	36.35
2.560	51.60	5.920	44.81	9.280	40.01	12.640	36.35
2.640	51.60	6.000	44.81	9.360	40.01	12.720	36.35
2.720	51.60	6.080	44.81	9.440	40.01	12.800	36.35
2.800	51.08	6.160	44.36	9.520	40.01	12.880	35.96
2.880	51.08	6.240	44.36	9.600	39.59	12.960	35.96
2.960	50.57	6.320	44.36	9.680	39.59	13.040	35.96
3.040	50.57	6.400	43.91	9.760	39.59	13.120	35.96
3.120	50.57	6.480	43.91	9.840	39.59	13.200	35.96
3.200	50.06	6.560	43.91	9.920	39.18	13.280	35.56
3.280	50.06	6.640	43.91	10.000	39.18	13.360	35.56

Time (hours)	Temperature (*C)	Time (hours)	Temperature (*C)	Time (hours)	Temperature (*C)
13.440	35.56	17.120	32.48	20.800	30.23
13.520	35.56	17.200	32.10	20.880	30.23
13.600	35.56	17.280	32.10	20.960	29.87
13.680	35.17	17.360	32.10	21.040	29.87
13.760	35.17	17.440	32.10	21.120	29.87
13.840	35.17	17.520	32.10	21.200	29.87
13.920	35.17	17.600	32.10	21.280	29.87
14.000	35.17	17.680	32.10	21.360	29.87
14.080	34.78	17.760	31.73	21.440	29.87
14.160	34.78	17.840	31.73	21.520	29.87
14.240	34.78	17.920	31.73	21.600	29.87
14.320	34.78	18.000	31.73	21.680	29.49
14.400	34.78	18.080	31.73	21.760	29.49
14.480	34.39	18.160	31.73	21.840	29.49
14.560	34.39	18.240	31.73	21.920	29.49
14.640	34.39	18.320	31.35	22.000	29.49
14.720	34.39	18.400	31.35	22.080	29.49
14.800	34.39	18.480	31.35	22.160	29.49
14.880	34.01	18.560	31.35	22.240	29.49
14.960	34.01	18.640	31.35	22.320	29.49
15.040	34.01	18.720	31.35	22.400	29.49
15.120	34.01	18.800	31.35	22.480	29.49
15.200	34.01	18.880	31.35	22.560	29.49
15.280	34.01	18.960	30.98	22.640	29.13
15.360	33.62	19.040	30.98	22.720	29.13
15.440	33.62	19.120	30.98	22.800	29.13
15.520	33.62	19.200	30.98	22.880	29.13
15.600	33.62	19.280	30.98	22.960	29.13
15.680	33.62	19.360	30.98	23.040	29.13
15.760	33.24	19.440	30.98	23.120	29.13
15.840	33.24	19.520	30.98	23.200	29.13
15.920	33.24	19.600	30.98	23.280	29.13
16.000	33.24	19.680	30.98	23.360	29.13
16.080	33.24	19.760	30.61	23.440	29.13
16.160	33.24	19.840	30.61	23.520	29.13
16.240	32.86	19.920	30.61	23.600	29.13
16.320	32.86	20.000	30.61	23.680	29.13
16.400	32.86	20.080	30.61	23.760	29.13
16.480	32.86	20.160	30.61	23.840	28.77
16.560	32.86	20.240	30.61	23.920	28.77
16.640	32.86	20.320	30.61		
16.720	32.48	20.400	30.23		
16.800	32.48	20.480	30.23		
16.880	32.48	20.560	30.23		
16.960	32.48	20.640	30.23		
17.040	32.48	20.720	30.23		

Trial 1 R-01-6.5B Water Temperature Profile

Ambient Temperature = 25.0°C

Time (hours)	Temperature (*C)	Time (hours)	Temperature (*C)	Time (hours)	Temperature (*C)	Time (hours)	Temperature (*C)
0.000	24.10	3.360	52.65	6.720	46.65	10.080	41.28
0.080	58.93	3.440	52.65	6.800	46.19	10.160	41.28
0.160	57.72	3.520	52.13	6.880	46.19	10.240	41.28
0.240	57.72	3.600	52.13	6.960	46.19	10.320	41.28
0.320	57.72	3.680	52.13	7.040	45.73	10.400	40.85
0.400	57.72	3.760	51.60	7.120	45.73	10.480	40.85
0.480	57.72	3.840	51.60	7.200	45.73	10.560	40.85
0.560	57.72	3.920	51.60	7.280	45.73	10.640	40.85
0.640	57.72	4.000	51.08	7.360	45.27	10.720	40.43
0.720	57.13	4.080	51.08	7.440	45.27	10.800	40.43
0.800	57.13	4.160	51.08	7.520	45.27	10.880	40.43
0.880	57.13	4.240	51.08	7.600	44.81	10.960	40.43
0.960	57.13	4.320	50.57	7.680	44.81	11.040	40.43
1.040	57.13	4.400	50.57	7.760	44.81	11.120	40.01
1.120	56.54	4.480	50.57	7.840	44.81	11.200	40.01
1.200	56.54	4.560	50.06	7.920	44.36	11.280	40.01
1.280	56.54	4.640	50.06	8.000	44.36	11.360	40.01
1.360	56.54	4.720	50.06	8.080	44.36	11.440	39.59
1.440	55.97	4.800	50.06	8.160	44.36	11.520	39.59
1.520	55.97	4.880	49.56	8.240	43.91	11.600	39.59
1.600	55.97	4.960	49.56	8.320	43.91	11.680	39.59
1.680	55.97	5.040	49.56	8.400	43.91	11.760	39.59
1.760	55.97	5.120	49.07	8.480	43.46	11.840	39.18
1.840	55.39	5.200	49.07	8.560	43.46	11.920	39.18
1.920	55.39	5.280	49.07	8.640	43.46	12.000	39.18
2.000	55.39	5.360	48.57	8.720	43.46	12.080	39.18
2.080	54.83	5.440	48.57	8.800	43.02	12.160	39.18
2.160	54.83	5.520	48.57	8.880	43.02	12.240	38.77
2.240	54.83	5.600	48.57	8.960	43.02	12.320	38.77
2.320	54.83	5.680	48.09	9.040	43.02	12.400	38.77
2.400	54.28	5.760	48.09	9.120	42.58	12.480	38.77
2.480	54.28	5.840	48.09	9.200	42.58	12.560	38.77
2.560	54.28	5.920	47.60	9.280	42.58	12.640	38.36
2.640	53.73	6.000	47.60	9.360	42.58	12.720	38.36
2.720	53.73	6.080	47.60	9.440	42.14	12.800	38.36
2.800	53.73	6.160	47.60	9.520	42.14	12.880	38.36
2.880	53.73	6.240	47.13	9.600	42.14	12.960	38.36
2.960	53.19	6.320	47.13	9.680	42.14	13.040	37.95
3.040	53.19	6.400	47.13	9.760	41.71	13.120	37.95
3.120	53.19	6.480	46.65	9.840	41.71	13.200	37.95
3.200	52.65	6.560	46.65	9.920	41.71	13.280	37.95
3.280	52.65	6.640	46.65	10.000	41.71	13.360	37.95

Time (hours)	Temperature (*C)	Time (hours)	Temperature (*C)	Time (hours)	Temperature (*C)
13.440	37.95	17.120	34.39	20.800	31.35
13.520	37.54	17.200	34.39	20.880	30.98
13.600	37.54	17.280	34.39	20.960	30.98
13.680	37.54	17.360	34.39	21.040	30.98
13.760	37.54	17.440	34.39	21.120	30.98
13.840	37.54	17.520	34.01	21.200	30.98
13.920	37.14	17.600	34.01	21.280	30.98
14.000	37.14	17.680	34.01	21.360	30.61
14.080	37.14	17.760	34.01	21.440	30.61
14.160	37.14	17.840	34.01	21.520	30.61
14.240	37.14	17.920	33.62	21.600	30.61
14.320	37.14	18.000	33.62	21.680	30.61
14.400	36.74	18.080	33.62	21.760	30.23
14.480	36.74	18.160	33.62	21.840	30.23
14.560	36.74	18.240	33.62	21.920	30.23
14.640	36.74	18.320	33.62	22.000	30.23
14.720	36.74	18.400	33.24	22.080	30.23
14.800	36.74	18.480	33.24	22.160	29.87
14.880	36.35	18.560	33.24	22.240	29.87
14.960	36.35	18.640	33.24	22.320	29.87
15.040	36.35	18.720	33.24	22.400	29.87
15.120	36.35	18.800	32.86	22.480	29.87
15.200	36.35	18.880	32.86	22.560	29.87
15.280	35.96	18.960	32.86	22.640	29.49
15.360	35.96	19.040	32.86	22.720	29.49
15.440	35.96	19.120	32.86	22.800	29.49
15.520	35.96	19.200	32.48	22.880	29.49
15.600	35.96	19.280	32.48	22.960	29.49
15.680	35.96	19.360	32.48	23.040	29.49
15.760	35.56	19.440	32.48	23.120	29.13
15.840	35.56	19.520	32.48	23.200	29.13
15.920	35.56	19.600	32.10	23.280	29.13
16.000	35.56	19.680	32.10	23.360	29.13
16.080	35.56	19.760	32.10	23.440	29.13
16.160	35.56	19.840	32.10	23.520	29.13
16.240	35.17	19.920	32.10	23.600	28.77
16.320	35.17	20.000	31.73	23.680	28.77
16.400	35.17	20.080	31.73	23.760	28.77
16.480	35.17	20.160	31.73	23.840	28.77
16.560	35.17	20.240	31.73	23.920	28.77
16.640	34.78	20.320	31.73		
16.720	34.78	20.400	31.35		
16.800	34.78	20.480	31.35		
16.880	34.78	20.560	31.35		
16.960	34.78	20.640	31.35		
17.040	34.39	20.720	31.35		

Trial 2 R-01-6.5B Water Temperature Profile

Ambient Temperature = 25.0°C

Time (hours)	Temperature (*C)	Time (hours)	Temperature (*C)	Time (hours)	Temperature (*C)	Time (hours)	Temperature (*C)
0.000	23.28	3.360	52.56	6.720	46.56	10.080	41.62
0.080	64.07	3.440	52.56	6.800	46.56	10.160	41.19
0.160	62.03	3.520	52.03	6.880	46.09	10.240	41.19
0.240	61.37	3.600	52.03	6.960	46.09	10.320	41.19
0.320	60.72	3.680	52.03	7.040	46.09	10.400	41.19
0.400	60.08	3.760	51.50	7.120	45.63	10.480	41.19
0.480	59.45	3.840	51.50	7.200	45.63	10.560	40.76
0.560	59.45	3.920	51.50	7.280	45.63	10.640	40.76
0.640	59.45	4.000	51.50	7.360	45.17	10.720	40.76
0.720	58.83	4.080	50.99	7.440	45.17	10.800	40.76
0.800	58.83	4.160	50.99	7.520	45.17	10.880	40.34
0.880	58.22	4.240	50.99	7.600	44.71	10.960	40.34
0.960	58.22	4.320	50.48	7.680	44.71	11.040	40.34
1.040	58.22	4.400	50.48	7.760	44.71	11.120	40.34
1.120	57.62	4.480	50.48	7.840	44.71	11.200	40.34
1.200	57.62	4.560	49.97	7.920	44.26	11.280	39.92
1.280	57.62	4.640	49.97	8.000	44.26	11.360	39.92
1.360	57.03	4.720	49.97	8.080	44.26	11.440	39.92
1.440	57.03	4.800	49.97	8.160	43.81	11.520	39.92
1.520	57.03	4.880	49.47	8.240	43.81	11.600	39.92
1.600	56.44	4.960	49.47	8.320	43.81	11.680	39.50
1.680	56.44	5.040	49.47	8.400	43.81	11.760	39.50
1.760	56.44	5.120	48.97	8.480	43.37	11.840	39.50
1.840	55.87	5.200	48.97	8.560	43.37	11.920	39.50
1.920	55.87	5.280	48.97	8.640	43.37	12.000	39.50
2.000	55.87	5.360	48.97	8.720	43.37	12.080	39.08
2.080	55.30	5.440	48.48	8.800	42.93	12.160	39.08
2.160	55.30	5.520	48.48	8.880	42.93	12.240	39.08
2.240	55.30	5.600	48.48	8.960	42.93	12.320	39.08
2.320	54.74	5.680	48.48	9.040	42.93	12.400	39.08
2.400	54.74	5.760	47.99	9.120	42.49	12.480	38.67
2.480	54.74	5.840	47.99	9.200	42.49	12.560	38.67
2.560	54.18	5.920	47.99	9.280	42.49	12.640	38.67
2.640	54.18	6.000	47.99	9.360	42.49	12.720	38.67
2.720	54.18	6.080	47.51	9.440	42.05	12.800	38.67
2.800	53.63	6.160	47.51	9.520	42.05	12.880	38.67
2.880	53.63	6.240	47.51	9.600	42.05	12.960	38.26
2.960	53.63	6.320	47.03	9.680	42.05	13.040	38.26
3.040	53.09	6.400	47.03	9.760	42.05	13.120	38.26
3.120	53.09	6.480	47.03	9.840	41.62	13.200	38.26
3.200	53.09	6.560	46.56	9.920	41.62	13.280	38.26
3.280	52.56	6.640	46.56	10.000	41.62	13.360	38.26

Time (hours)	Temperature (*C)	Time (hours)	Temperature (*C)	Time (hours)	Temperature (*C)
13.440	37.85	17.120	35.07	20.800	32.01
13.520	37.85	17.200	35.07	20.880	32.01
13.600	37.85	17.280	35.07	20.960	32.01
13.680	37.85	17.360	35.07	21.040	32.01
13.760	37.85	17.440	35.07	21.120	32.01
13.840	37.85	17.520	34.68	21.200	32.01
13.920	37.44	17.600	34.68	21.280	31.63
14.000	37.44	17.680	34.68	21.360	31.63
14.080	37.44	17.760	34.68	21.440	31.63
14.160	37.44	17.840	34.68	21.520	31.63
14.240	37.44	17.920	34.68	21.600	31.63
14.320	37.44	18.000	34.68	21.680	31.63
14.400	37.04	18.080	34.29	21.760	31.63
14.480	37.04	18.160	34.29	21.840	31.63
14.560	37.04	18.240	34.29	21.920	31.25
14.640	37.04	18.320	34.29	22.000	31.25
14.720	37.04	18.400	34.29	22.080	31.25
14.800	37.04	18.480	34.29	22.160	31.25
14.880	36.64	18.560	33.91	22.240	31.25
14.960	36.64	18.640	33.91	22.320	31.25
15.040	36.64	18.720	33.91	22.400	31.25
15.120	36.64	18.800	33.91	22.480	31.25
15.200	36.64	18.880	33.91	22.560	31.25
15.280	36.64	18.960	33.91	22.640	31.25
15.360	36.25	19.040	33.52	22.720	31.25
15.440	36.25	19.120	33.52	22.800	30.88
15.520	36.25	19.200	33.52	22.880	30.88
15.600	36.25	19.280	33.52	22.960	30.88
15.680	36.25	19.360	33.52	23.040	30.88
15.760	36.25	19.440	33.52	23.120	30.88
15.840	36.25	19.520	33.14	23.200	30.88
15.920	35.85	19.600	33.14	23.280	30.88
16.000	35.85	19.680	33.14	23.360	30.88
16.080	35.85	19.760	33.14	23.440	30.88
16.160	35.85	19.840	33.14	23.520	30.88
16.240	35.85	19.920	32.76	23.600	30.51
16.320	35.85	20.000	32.76	23.680	30.51
16.400	35.85	20.080	32.76	23.760	30.51
16.480	35.46	20.160	32.76	23.840	30.51
16.560	35.46	20.240	32.76	23.920	30.51
16.640	35.46	20.320	32.38		
16.720	35.46	20.400	32.38		
16.800	35.46	20.480	32.38		
16.880	35.46	20.560	32.38		
16.960	35.07	20.640	32.38		
17.040	35.07	20.720	32.38		

Trial 3 R-01-6.5B Water Temperature Profile

Ambient Temperature = 22.0°C

Time (hours)	Temperature (*C)	Time (hours)	Temperature (*C)	Time (hours)	Temperature (*C)	Time (hours)	Temperature (*C)
0.000	21.88	3.360	52.56	6.720	46.56	10.080	42.05
0.080	63.38	3.440	52.56	6.800	46.56	10.160	42.05
0.160	62.03	3.520	52.03	6.880	46.09	10.240	41.62
0.240	61.37	3.600	52.03	6.960	46.09	10.320	41.62
0.320	60.72	3.680	52.03	7.040	46.09	10.400	41.62
0.400	60.08	3.760	51.50	7.120	46.09	10.480	41.62
0.480	60.08	3.840	51.50	7.200	45.63	10.560	41.19
0.560	59.45	3.920	51.50	7.280	45.63	10.640	41.19
0.640	59.45	4.000	51.50	7.360	45.63	10.720	41.19
0.720	58.83	4.080	50.99	7.440	45.63	10.800	41.19
0.800	58.83	4.160	50.99	7.520	45.17	10.880	41.19
0.880	58.22	4.240	50.99	7.600	45.17	10.960	40.76
0.960	58.22	4.320	50.48	7.680	45.17	11.040	40.76
1.040	58.22	4.400	50.48	7.760	44.71	11.120	40.76
1.120	57.62	4.480	50.48	7.840	44.71	11.200	40.76
1.200	57.62	4.560	50.48	7.920	44.71	11.280	40.34
1.280	57.03	4.640	49.97	8.000	44.71	11.360	40.34
1.360	57.03	4.720	49.97	8.080	44.26	11.440	40.34
1.440	57.03	4.800	49.97	8.160	44.26	11.520	40.34
1.520	56.44	4.880	49.97	8.240	44.26	11.600	39.92
1.600	56.44	4.960	49.47	8.320	44.26	11.680	39.92
1.680	56.44	5.040	49.47	8.400	44.26	11.760	39.92
1.760	55.87	5.120	49.47	8.480	43.81	11.840	39.92
1.840	55.87	5.200	48.97	8.560	43.81	11.920	39.50
1.920	55.30	5.280	48.97	8.640	43.81	12.000	39.50
2.000	55.30	5.360	48.97	8.720	43.81	12.080	39.50
2.080	55.30	5.440	48.48	8.800	43.81	12.160	39.50
2.160	55.30	5.520	48.48	8.880	43.37	12.240	39.08
2.240	54.74	5.600	48.48	8.960	43.37	12.320	39.08
2.320	54.74	5.680	48.48	9.040	43.37	12.400	39.08
2.400	54.18	5.760	47.99	9.120	43.37	12.480	39.08
2.480	54.18	5.840	47.99	9.200	42.93	12.560	38.67
2.560	54.18	5.920	47.99	9.280	42.93	12.640	38.67
2.640	53.63	6.000	47.99	9.360	42.93	12.720	38.67
2.720	53.63	6.080	47.51	9.440	42.93	12.800	38.67
2.800	53.63	6.160	47.51	9.520	42.93	12.880	38.26
2.880	53.63	6.240	47.51	9.600	42.49	12.960	38.26
2.960	53.09	6.320	47.03	9.680	42.49	13.040	38.26
3.040	53.09	6.400	47.03	9.760	42.49	13.120	38.26
3.120	53.09	6.480	47.03	9.840	42.49	13.200	37.85
3.200	52.56	6.560	47.03	9.920	42.05	13.280	37.85
3.280	52.56	6.640	46.56	10.000	42.05	13.360	37.85

Time (hours)	Temperature (*C)	Time (hours)	Temperature (*C)	Time (hours)	Temperature (*C)
13.440	37.85	17.120	34.29	20.800	32.01
13.520	37.85	17.200	34.29	20.880	32.01
13.600	37.44	17.280	34.29	20.960	32.01
13.680	37.44	17.360	34.29	21.040	31.63
13.760	37.44	17.440	34.29	21.120	31.63
13.840	37.44	17.520	34.29	21.200	31.63
13.920	37.44	17.600	33.91	21.280	31.63
14.000	37.04	17.680	33.91	21.360	31.63
14.080	37.04	17.760	33.91	21.440	31.63
14.160	37.04	17.840	33.91	21.520	31.63
14.240	37.04	17.920	33.91	21.600	31.63
14.320	37.04	18.000	33.91	21.680	31.63
14.400	36.64	18.080	33.52	21.760	31.25
14.480	36.64	18.160	33.52	21.840	31.25
14.560	36.64	18.240	33.52	21.920	31.25
14.640	36.64	18.320	33.52	22.000	31.25
14.720	36.64	18.400	33.52	22.080	31.25
14.800	36.25	18.480	33.52	22.160	31.25
14.880	36.25	18.560	33.52	22.240	31.25
14.960	36.25	18.640	33.14	22.320	31.25
15.040	36.25	18.720	33.14	22.400	31.25
15.120	36.25	18.800	33.14	22.480	30.88
15.200	35.85	18.880	33.14	22.560	30.88
15.280	35.85	18.960	33.14	22.640	30.88
15.360	35.85	19.040	33.14	22.720	30.88
15.440	35.85	19.120	33.14	22.800	30.88
15.520	35.85	19.200	32.76	22.880	30.88
15.600	35.85	19.280	32.76	22.960	30.88
15.680	35.46	19.360	32.76	23.040	30.51
15.760	35.46	19.440	32.76	23.120	30.51
15.840	35.46	19.520	32.76	23.200	30.51
15.920	35.46	19.600	32.76	23.280	30.51
16.000	35.46	19.680	32.38	23.360	30.51
16.080	35.07	19.760	32.38	23.440	30.51
16.160	35.07	19.840	32.38	23.520	30.51
16.240	35.07	19.920	32.38	23.600	30.13
16.320	35.07	20.000	32.38	23.680	30.13
16.400	35.07	20.080	32.38	23.760	30.13
16.480	35.07	20.160	32.38	23.840	30.13
16.560	34.68	20.240	32.38	23.920	30.13
16.640	34.68	20.320	32.38		
16.720	34.68	20.400	32.01		
16.800	34.68	20.480	32.01		
16.880	34.68	20.560	32.01		
16.960	34.68	20.640	32.01		
17.040	34.29	20.720	32.01		

Trial 1 R-01-8.5A Water Temperature Profile

Ambient Temperture = 25.0*C

Time (hours)	Temperature (*C)	Time (hours)	Temperature (*C)	Time (hours)	Temperature (*C)	Time (hours)	Temperature (*C)
0.000	78.38	10.080	55.97	20.160	46.19	30.240	40.01
0.240	72.74	10.320	55.39	20.400	46.19	30.480	40.01
0.480	71.03	10.560	55.39	20.640	45.73	30.720	40.01
0.720	69.40	10.800	54.83	20.880	45.73	30.960	39.59
0.960	69.40	11.040	54.83	21.120	45.73	31.200	39.59
1.200	68.61	11.280	54.28	21.360	45.27	31.440	39.59
1.440	67.83	11.520	54.28	21.600	45.27	31.680	39.59
1.680	67.07	11.760	53.73	21.840	44.81	31.920	39.18
1.920	66.33	12.000	53.73	22.080	44.81	32.160	39.18
2.160	66.33	12.240	53.73	22.320	44.81	32.400	39.18
2.400	65.59	12.480	53.19	22.560	44.36	32.640	39.18
2.640	65.59	12.720	53.19	22.800	44.36	32.880	38.77
2.880	64.88	12.960	52.65	23.040	44.36	33.120	38.77
3.120	64.88	13.200	52.65	23.280	43.91	33.360	38.77
3.360	64.18	13.440	52.13	23.520	43.91	33.600	38.36
3.600	64.18	13.680	52.13	23.760	43.91	33.840	38.36
3.840	63.48	13.920	51.60	24.000	43.46	34.080	38.36
4.080	63.48	14.160	51.60	24.240	43.46	34.320	38.36
4.320	62.80	14.400	51.60	24.480	43.46	34.560	37.95
4.560	62.80	14.640	51.08	24.720	43.02	34.800	37.95
4.800	62.13	14.880	51.08	24.960	43.02	35.040	37.95
5.040	62.13	15.120	50.57	25.200	43.02	35.280	37.95
5.280	61.47	15.360	50.57	25.440	42.58	35.520	37.54
5.520	61.47	15.600	50.06	25.680	42.58	35.760	37.54
5.760	60.82	15.840	50.06	25.920	42.58	36.000	37.54
6.000	60.18	16.080	49.56	26.160	42.14	36.240	37.54
6.240	60.18	16.320	49.56	26.400	42.14	36.480	37.14
6.480	60.18	16.560	49.07	26.640	42.14	36.720	37.14
6.720	59.55	16.800	49.07	26.880	42.14	36.960	37.14
6.960	59.55	17.040	48.57	27.120	41.71	37.200	36.74
7.200	58.93	17.280	48.57	27.360	41.71	37.440	36.74
7.440	58.93	17.520	48.57	27.600	41.71	37.680	36.74
7.680	58.32	17.760	48.09	27.840	41.28	37.920	36.74
7.920	58.32	18.000	48.09	28.080	41.28	38.160	36.35
8.160	57.72	18.240	47.60	28.320	41.28	38.400	36.35
8.400	57.72	18.480	47.60	28.560	40.85	38.640	36.35
8.640	57.13	18.720	47.60	28.800	40.85	38.880	36.35
8.880	57.13	18.960	47.13	29.040	40.85	39.120	35.96
9.120	56.54	19.200	47.13	29.280	40.43	39.360	35.96
9.360	56.54	19.440	46.65	29.520	40.43	39.600	35.96
9.600	55.97	19.680	46.65	29.760	40.43	39.840	35.56
9.840	55.97	19.920	46.65	30.000	40.43	40.080	35.56

Time (hours)	Temperature (*C)	Time (hours)	Temperature (*C)	Time (hours)	Temperature (*C)
40.320	35.56	51.360	31.35	62.400	28.40
40.560	35.56	51.600	31.35	62.640	28.40
40.800	35.17	51.840	31.35	62.880	28.40
41.040	35.17	52.080	31.35	63.120	28.40
41.280	35.17	52.320	30.98	63.360	28.40
41.520	34.78	52.560	30.98	63.600	28.40
41.760	34.78	52.800	30.98	63.840	28.40
42.000	34.78	53.040	30.98	64.080	28.40
42.240	34.39	53.280	30.61	64.320	28.04
42.480	34.39	53.520	30.61	64.560	28.04
42.720	34.39	53.760	30.61	64.800	28.04
42.960	34.01	54.000	30.61	65.040	28.04
43.200	34.01	54.240	30.61	65.280	28.04
43.440	34.01	54.480	30.61	65.520	28.04
43.680	34.01	54.720	30.23	65.760	27.68
43.920	34.01	54.960	30.23	66.000	27.68
44.160	33.62	55.200	30.23	66.240	27.68
44.400	33.62	55.440	30.23	66.480	27.68
44.640	33.62	55.680	30.23	66.720	27.68
44.880	33.62	55.920	29.87	66.960	27.68
45.120	33.24	56.160	29.87	67.200	27.68
45.360	33.24	56.400	29.87	67.440	27.68
45.600	33.24	56.640	29.87	67.680	27.68
45.840	33.24	56.880	29.87	67.920	27.32
46.080	33.24	57.120	29.87	68.160	27.32
46.320	32.86	57.360	29.49	68.400	27.32
46.560	32.86	57.600	29.49	68.640	27.32
46.800	32.86	57.840	29.49	68.880	27.32
47.040	32.86	58.080	29.49	69.120	27.32
47.280	32.86	58.320	29.49	69.360	27.32
47.520	32.48	58.560	29.49	69.600	27.32
47.760	32.48	58.800	29.49	69.840	27.32
48.000	32.48	59.040	29.49	70.080	27.32
48.240	32.48	59.280	29.13	70.320	27.32
48.480	32.48	59.520	29.13	70.560	27.32
48.720	32.10	59.760	29.13	70.800	26.96
48.960	32.10	60.000	29.13	71.040	26.96
49.200	32.10	60.240	29.13	71.280	26.96
49.440	32.10	60.480	29.13	71.520	26.96
49.680	32.10	60.720	29.13	71.760	26.96
49.920	31.73	60.960	28.77		
50.160	31.73	61.200	28.77		
50.400	31.73	61.440	28.77		
50.640	31.73	61.680	28.77		
50.880	31.73	61.920	28.77		
51.120	31.35	62.160	28.77		

Trial 2 R-01-8.5A Water Temperature Profile

Ambient Temperature = 22.0°C

Time (hours)	Temperature (*C)	Time (hours)	Temperature (*C)	Time (hours)	Temperature (*C)	Time (hours)	Temperature (*C)
0.000	70.10	10.080	49.97	20.160	42.49	30.240	37.44
0.240	64.78	10.320	49.47	20.400	42.49	30.480	37.44
0.480	62.70	10.560	49.47	20.640	42.49	30.720	37.04
0.720	62.03	10.800	49.47	20.880	42.05	30.960	37.04
0.960	61.37	11.040	48.97	21.120	42.05	31.200	37.04
1.200	60.72	11.280	48.97	21.360	42.05	31.440	37.04
1.440	60.08	11.520	48.48	21.600	41.62	31.680	36.64
1.680	60.08	11.760	48.48	21.840	41.62	31.920	36.64
1.920	59.45	12.000	47.99	22.080	41.62	32.160	36.64
2.160	58.83	12.240	47.99	22.320	41.19	32.400	36.64
2.400	58.83	12.480	47.99	22.560	41.19	32.640	36.25
2.640	58.22	12.720	47.51	22.800	41.19	32.880	36.25
2.880	58.22	12.960	47.51	23.040	40.76	33.120	36.25
3.120	57.62	13.200	47.03	23.280	40.76	33.360	36.25
3.360	57.03	13.440	46.56	23.520	40.76	33.600	35.85
3.600	57.03	13.680	44.71	23.760	40.76	33.840	35.85
3.840	56.44	13.920	47.03	24.000	40.34	34.080	35.85
4.080	56.44	14.160	46.56	24.240	40.34	34.320	35.85
4.320	55.87	14.400	46.56	24.480	40.34	34.560	35.46
4.560	55.87	14.640	46.56	24.720	39.92	34.800	35.46
4.800	55.30	14.880	46.09	24.960	39.92	35.040	35.46
5.040	55.30	15.120	46.09	25.200	39.92	35.280	35.46
5.280	54.74	15.360	45.63	25.440	39.50	35.520	35.07
5.520	54.74	15.600	45.63	25.680	39.50	35.760	35.07
5.760	54.18	15.840	45.63	25.920	39.50	36.000	35.07
6.000	54.18	16.080	45.17	26.160	39.08	36.240	35.07
6.240	53.63	16.320	45.17	26.400	39.08	36.480	34.68
6.480	53.63	16.560	45.17	26.640	39.08	36.720	34.68
6.720	53.09	16.800	44.71	26.880	39.08	36.960	34.68
6.960	53.09	17.040	44.71	27.120	38.67	37.200	34.68
7.200	52.56	17.280	44.26	27.360	38.67	37.440	34.68
7.440	52.56	17.520	44.26	27.600	38.67	37.680	34.68
7.680	52.03	17.760	44.26	27.840	38.26	37.920	34.29
7.920	52.03	18.000	43.81	28.080	38.26	38.160	34.29
8.160	51.50	18.240	43.81	28.320	38.26	38.400	34.29
8.400	51.50	18.480	43.81	28.560	38.26	38.640	34.29
8.640	50.99	18.720	43.37	28.800	37.85	38.880	34.29
8.880	50.99	18.960	43.37	29.040	37.85	39.120	33.91
9.120	50.99	19.200	43.37	29.280	37.85	39.360	33.91
9.360	50.48	19.440	42.93	29.520	37.85	39.600	33.91
9.600	50.48	19.680	42.93	29.760	37.44	39.840	33.91
9.840	49.97	19.920	42.93	30.000	37.44	40.080	33.91

Time (hours)	Temperature (*C)
40.320	33.52
40.560	33.52
40.800	33.52
41.040	33.52
41.280	33.52
41.520	33.14
41.760	33.14
42.000	33.14
42.240	33.14
42.480	33.14
42.720	32.76
42.960	32.76
43.200	32.76
43.440	32.76
43.680	32.76
43.920	32.38
44.160	32.38
44.400	32.38
44.640	32.38
44.880	32.38
45.120	32.38
45.360	32.38
45.600	32.01
45.840	32.01
46.080	32.01
46.320	32.01
46.560	32.01
46.800	32.01
47.040	32.01
47.280	32.01
47.520	31.63
47.760	31.63
48.000	31.63
48.240	23.99

Trial 3 R-01-8.5A Water Temperature Profile

Ambient Temperature = 26.0°C

Time (hours)	Temperature (*C)	Time (hours)	Temperature (*C)	Time (hours)	Temperature (*C)	Time (hours)	Temperature (*C)
0.000	66.97	10.080	50.99	20.160	43.81	30.240	39.08
0.240	62.70	10.320	50.48	20.400	43.81	30.480	38.67
0.480	61.37	10.560	50.48	20.640	43.37	30.720	38.67
0.720	60.72	10.800	50.48	20.880	43.37	30.960	38.67
0.960	60.72	11.040	49.97	21.120	43.37	31.200	38.67
1.200	60.08	11.280	49.97	21.360	42.93	31.440	38.26
1.440	59.45	11.520	49.97	21.600	42.93	31.680	38.26
1.680	59.45	11.760	49.47	21.840	42.93	31.920	38.26
1.920	58.83	12.000	49.47	22.080	42.93	32.160	38.26
2.160	58.83	12.240	48.97	22.320	42.49	32.400	37.85
2.400	58.22	12.480	48.97	22.560	42.49	32.640	37.85
2.640	58.22	12.720	48.97	22.800	42.49	32.880	37.85
2.880	57.62	12.960	48.48	23.040	42.49	33.120	37.85
3.120	57.62	13.200	48.48	23.280	42.05	33.360	37.44
3.360	57.03	13.440	48.48	23.520	42.05	33.600	37.44
3.600	57.03	13.680	47.99	23.760	42.05	33.840	37.44
3.840	56.44	13.920	47.99	24.000	41.62	34.080	37.44
4.080	56.44	14.160	47.99	24.240	41.62	34.320	37.04
4.320	55.87	14.400	47.51	24.480	41.62	34.560	37.04
4.560	55.87	14.640	47.51	24.720	41.62	34.800	37.04
4.800	55.87	14.880	47.51	24.960	41.19	35.040	37.04
5.040	55.30	15.120	47.03	25.200	41.19	35.280	36.64
5.280	55.30	15.360	47.03	25.440	41.19	35.520	36.64
5.520	54.74	15.600	47.03	25.680	41.19	35.760	36.64
5.760	54.74	15.840	46.56	25.920	40.76	36.000	36.64
6.000	54.18	16.080	46.56	26.160	40.76	36.240	36.64
6.240	54.18	16.320	46.09	26.400	40.76	36.480	36.25
6.480	54.18	16.560	46.09	26.640	40.76	36.720	36.25
6.720	53.63	16.800	46.09	26.880	40.34	36.960	36.25
6.960	53.63	17.040	45.63	27.120	40.34	37.200	36.25
7.200	53.09	17.280	45.63	27.360	40.34	37.440	36.25
7.440	53.09	17.520	45.63	27.600	40.34	37.680	35.85
7.680	53.09	17.760	45.17	27.840	39.92	37.920	35.85
7.920	52.56	18.000	45.17	28.080	39.92	38.160	35.85
8.160	52.56	18.240	45.17	28.320	39.92	38.400	35.85
8.400	52.03	18.480	44.71	28.560	39.92	38.640	35.85
8.640	52.03	18.720	44.71	28.800	39.50	38.880	35.46
8.880	52.03	18.960	44.71	29.040	39.50	39.120	35.46
9.120	51.50	19.200	44.26	29.280	39.50	39.360	35.46
9.360	51.50	19.440	44.26	29.520	39.50	39.600	35.46
9.600	50.99	19.680	44.26	29.760	39.08	39.840	35.46
9.840	50.99	19.920	43.81	30.000	39.08	40.080	35.07

Time (hours)	Temperature (*C)	Time (hours)	Temperature (*C)	Time (hours)	Temperature (*C)
40.320	35.07	51.360	31.63	62.400	29.03
40.560	35.07	51.600	31.63	62.640	28.66
40.800	35.07	51.840	31.63	62.880	28.66
41.040	34.68	52.080	31.63	63.120	28.66
41.280	34.68	52.320	31.63	63.360	28.66
41.520	34.68	52.560	31.25	63.600	28.66
41.760	34.68	52.800	31.25	63.840	28.66
42.000	34.68	53.040	31.25	64.080	28.66
42.240	34.29	53.280	31.25	64.320	28.66
42.480	34.29	53.520	31.25	64.560	28.66
42.720	34.29	53.760	30.88	64.800	28.29
42.960	34.29	54.000	30.88	65.040	28.29
43.200	33.91	54.240	30.88	65.280	28.29
43.440	33.91	54.480	30.88	65.520	28.29
43.680	33.91	54.720	30.88	65.760	28.29
43.920	33.91	54.960	30.88	66.000	28.29
44.160	33.91	55.200	30.51	66.240	28.29
44.400	33.52	55.440	30.51	66.480	28.29
44.640	33.52	55.680	30.51	66.720	27.93
44.880	33.52	55.920	30.51	66.960	27.93
45.120	33.52	56.160	30.51	67.200	27.93
45.360	33.52	56.400	30.13	67.440	27.93
45.600	33.14	56.640	30.13	67.680	27.93
45.840	33.14	56.880	30.13	67.920	27.93
46.080	33.14	57.120	30.13	68.160	27.93
46.320	33.14	57.360	30.13	68.400	27.93
46.560	33.14	57.600	30.13	68.640	27.93
46.800	32.76	57.840	29.76	68.880	27.57
47.040	32.76	58.080	29.76	69.120	27.57
47.280	32.76	58.320	29.76	69.360	27.57
47.520	32.76	58.560	29.76	69.600	27.57
47.760	32.76	58.800	29.76	69.840	27.57
48.000	32.76	59.040	29.76	70.080	27.57
48.240	32.38	59.280	29.76	70.320	27.57
48.480	32.38	59.520	29.39	70.560	27.57
48.720	32.38	59.760	29.39	70.800	27.22
48.960	32.38	60.000	29.39	71.040	27.22
49.200	32.38	60.240	29.39	71.280	27.22
49.440	32.38	60.480	29.39	71.520	27.22
49.680	32.01	60.720	29.39	71.760	27.22
49.920	32.01	60.960	29.03		
50.160	32.01	61.200	29.03		
50.400	32.01	61.440	29.03		
50.640	32.01	61.680	29.03		
50.880	32.01	61.920	29.03		
51.120	31.63	62.160	29.03		

Trial 1 R-01-8.5B Water Temperature Profile

Ambient Temperature = 25.0°C

Time (hours)	Temperature (*C)	Time (hours)	Temperature (*C)	Time (hours)	Temperature (*C)	Time (hours)	Temperature (*C)
0.000	19.89	10.080	47.13	20.160	39.59	30.240	35.56
0.240	54.83	10.320	47.13	20.400	39.59	30.480	35.17
0.480	56.54	10.560	46.65	20.640	39.18	30.720	35.17
0.720	56.54	10.800	46.65	20.880	39.18	30.960	35.17
0.960	56.54	11.040	46.19	21.120	39.18	31.200	35.17
1.200	55.97	11.280	46.19	21.360	38.77	31.440	34.78
1.440	55.39	11.520	45.73	21.600	38.77	31.680	34.78
1.680	55.39	11.760	45.73	21.840	38.77	31.920	34.78
1.920	55.39	12.000	45.27	22.080	38.36	32.160	34.39
2.160	54.83	12.240	45.27	22.320	38.36	32.400	34.39
2.400	54.83	12.480	45.27	22.560	38.36	32.640	34.39
2.640	54.28	12.720	44.81	22.800	38.36	32.880	34.39
2.880	54.28	12.960	44.81	23.040	37.95	33.120	34.01
3.120	53.73	13.200	44.36	23.280	37.95	33.360	34.01
3.360	53.73	13.440	44.36	23.520	37.95	33.600	34.01
3.600	53.19	13.680	44.36	23.760	37.95	33.840	34.01
3.840	53.19	13.920	43.91	24.000	37.54	34.080	34.01
4.080	52.65	14.160	43.91	24.240	37.54	34.320	33.62
4.320	52.65	14.400	43.46	24.480	37.54	34.560	33.62
4.560	52.13	14.640	43.46	24.720	37.54	34.800	33.62
4.800	52.13	14.880	43.46	24.960	37.54	35.040	33.24
5.040	51.60	15.120	43.02	25.200	37.54	35.280	33.24
5.280	51.60	15.360	43.02	25.440	37.54	35.520	33.24
5.520	51.08	15.600	43.02	25.680	37.14	35.760	33.24
5.760	51.08	15.840	42.58	25.920	37.14	36.000	33.24
6.000	50.57	16.080	42.58	26.160	37.14	36.240	32.86
6.240	50.57	16.320	42.14	26.400	37.14	36.480	32.86
6.480	50.06	16.560	42.14	26.640	37.14	36.720	32.86
6.720	50.06	16.800	42.14	26.880	36.74	36.960	32.86
6.960	49.56	17.040	41.71	27.120	36.74	37.200	32.48
7.200	49.56	17.280	41.71	27.360	36.74	37.440	32.48
7.440	49.56	17.520	41.28	27.600	36.74	37.680	32.48
7.680	49.07	17.760	41.28	27.840	36.35	37.920	32.48
7.920	48.57	18.000	41.28	28.080	36.35	38.160	32.10
8.160	48.57	18.240	40.85	28.320	36.35	38.400	32.10
8.400	48.57	18.480	40.85	28.560	36.35	38.640	32.10
8.640	48.09	18.720	40.43	28.800	35.96	38.880	32.10
8.880	48.09	18.960	40.43	29.040	35.96	39.120	32.10
9.120	47.60	19.200	40.43	29.280	35.96	39.360	31.73
9.360	47.60	19.440	40.01	29.520	35.56	39.600	31.73
9.600	47.60	19.680	40.01	29.760	35.56	39.840	31.73
9.840	47.13	19.920	40.01	30.000	35.56	40.080	31.35

Time (hours)	Temperature (*C)	Time (hours)	Temperature (*C)	Time (hours)	Temperature (*C)
40.320	31.35	51.360	28.77	62.400	26.61
40.560	31.35	51.600	28.77	62.640	26.61
40.800	31.35	51.840	28.77	62.880	26.61
41.040	30.98	52.080	28.77	63.120	26.61
41.280	30.98	52.320	28.77	63.360	26.61
41.520	30.98	52.560	28.77	63.600	26.61
41.760	30.98	52.800	28.40	63.840	26.24
42.000	30.61	53.040	28.40	64.080	26.24
42.240	30.61	53.280	28.40	64.320	26.24
42.480	30.61	53.520	28.40	64.560	26.24
42.720	30.61	53.760	28.40	64.800	26.24
42.960	30.23	54.000	28.40	65.040	26.24
43.200	30.23	54.240	28.04	65.280	26.24
43.440	30.23	54.480	28.04	65.520	25.89
43.680	29.87	54.720	28.04	65.760	25.89
43.920	29.87	54.960	28.04	66.000	25.89
44.160	29.87	55.200	28.04	66.240	25.89
44.400	29.87	55.440	28.04	66.480	25.89
44.640	29.49	55.680	28.04	66.720	25.89
44.880	29.49	55.920	27.68	66.960	25.53
45.120	29.49	56.160	27.68	67.200	25.53
45.360	29.49	56.400	27.68	67.440	25.53
45.600	29.49	56.640	27.68	67.680	25.53
45.840	29.49	56.880	27.68	67.920	25.53
46.080	29.13	57.120	27.68	68.160	25.53
46.320	29.13	57.360	27.32	68.400	25.53
46.560	29.13	57.600	27.32	68.640	25.53
46.800	29.13	57.840	27.32	68.880	25.17
47.040	29.13	58.080	27.32	69.120	25.17
47.280	29.13	58.320	27.32	69.360	25.17
47.520	29.13	58.560	27.32	69.600	25.17
47.760	29.13	58.800	27.32	69.840	25.17
48.000	29.13	59.040	27.32	70.080	25.17
48.240	29.13	59.280	26.96	70.320	25.17
48.480	29.13	59.520	26.96	70.560	25.17
48.720	29.13	59.760	26.96	70.800	25.17
48.960	29.13	60.000	26.96	71.040	25.17
49.200	29.13	60.240	26.96	71.280	25.17
49.440	29.13	60.480	26.96	71.520	25.17
49.680	29.13	60.720	26.96	71.760	25.17
49.920	29.13	60.960	26.96		
50.160	29.13	61.200	26.96		
50.400	29.13	61.440	26.96		
50.640	29.13	61.680	26.61		
50.880	29.13	61.920	26.61		
51.120	29.13	62.160	26.61		

Trial 2 R-01-8.5B Water Temperature Profile

Ambient Temperature = 20.0°C

Time (hours)	Temperature (*C)	Time (hours)	Temperature (*C)	Time (hours)	Temperature (*C)	Time (hours)	Temperature (*C)
0.000	17.79	10.080	48.09	20.160	40.43	30.240	35.96
0.240	61.47	10.320	47.60	20.400	40.43	30.480	35.56
0.480	59.55	10.560	47.60	20.640	40.43	30.720	35.56
0.720	58.32	10.800	47.60	20.880	40.01	30.960	35.56
0.960	57.72	11.040	47.13	21.120	40.01	31.200	35.56
1.200	57.13	11.280	47.13	21.360	40.01	31.440	35.56
1.440	57.13	11.520	46.65	21.600	39.59	31.680	35.17
1.680	56.54	11.760	46.65	21.840	39.59	31.920	35.17
1.920	55.97	12.000	46.19	22.080	39.59	32.160	35.17
2.160	55.97	12.240	46.19	22.320	39.18	32.400	35.17
2.400	55.39	12.480	45.73	22.560	39.18	32.640	34.78
2.640	55.39	12.720	45.73	22.800	39.18	32.880	34.78
2.880	54.83	12.960	45.73	23.040	38.77	33.120	34.78
3.120	54.83	13.200	45.27	23.280	38.77	33.360	34.78
3.360	54.28	13.440	45.27	23.520	38.77	33.600	34.78
3.600	54.28	13.680	44.81	23.760	38.36	33.840	34.39
3.840	53.73	13.920	44.81	24.000	38.36	34.080	34.39
4.080	53.73	14.160	44.81	24.240	38.36	34.320	34.39
4.320	53.19	14.400	44.36	24.480	37.95	34.560	34.39
4.560	53.19	14.640	44.36	24.720	37.95	34.800	34.39
4.800	52.65	14.880	43.91	24.960	37.95	35.040	34.01
5.040	52.65	15.120	43.91	25.200	37.95	35.280	34.01
5.280	52.13	15.360	43.46	25.440	37.54	35.520	34.01
5.520	52.13	15.600	43.46	25.680	37.54	35.760	34.01
5.760	52.13	15.840	43.46	25.920	37.54	36.000	34.01
6.000	51.60	16.080	43.02	26.160	37.14	36.240	33.62
6.240	51.60	16.320	43.02	26.400	37.14	36.480	33.62
6.480	51.08	16.560	43.02	26.640	37.14	36.720	33.62
6.720	51.08	16.800	42.58	26.880	37.14	36.960	33.62
6.960	50.57	17.040	42.58	27.120	36.74	37.200	33.62
7.200	50.57	17.280	42.14	27.360	36.74	37.440	33.24
7.440	50.06	17.520	42.14	27.600	36.74	37.680	33.24
7.680	50.06	17.760	42.14	27.840	36.74	37.920	33.24
7.920	50.06	18.000	41.71	28.080	36.35	38.160	33.24
8.160	49.56	18.240	41.71	28.320	36.35	38.400	33.24
8.400	49.56	18.480	41.71	28.560	36.35	38.640	33.24
8.640	49.07	18.720	41.28	28.800	36.35	38.880	32.86
8.880	49.07	18.960	41.28	29.040	36.35	39.120	32.86
9.120	48.57	19.200	41.28	29.280	35.96	39.360	32.86
9.360	48.57	19.440	40.85	29.520	35.96	39.600	32.86
9.600	48.57	19.680	40.85	29.760	35.96	39.840	32.86
9.840	48.09	19.920	40.85	30.000	35.96	40.080	32.48

Time (hours)	Temperature (*C)	Time (hours)	Temperature (*C)	Time (hours)	Temperature (*C)
40.320	32.48	51.360	29.49	62.400	27.68
40.560	32.48	51.600	29.49	62.640	27.68
40.800	32.48	51.840	29.49	62.880	27.68
41.040	32.48	52.080	29.49	63.120	27.68
41.280	32.10	52.320	29.49	63.360	27.68
41.520	32.10	52.560	29.49	63.600	27.68
41.760	32.10	52.800	29.13	63.840	27.68
42.000	32.10	53.040	29.13	64.080	27.68
42.240	32.10	53.280	29.13	64.320	27.32
42.480	31.73	53.520	29.13	64.560	27.32
42.720	31.73	53.760	29.13	64.800	27.32
42.960	31.73	54.000	29.13	65.040	27.32
43.200	31.73	54.240	29.13	65.280	27.32
43.440	31.73	54.480	28.77	65.520	27.32
43.680	31.35	54.720	28.77	65.760	27.32
43.920	31.35	54.960	28.77	66.000	27.32
44.160	31.35	55.200	28.77	66.240	27.32
44.400	31.35	55.440	28.77	66.480	27.32
44.640	31.35	55.680	28.77	66.720	26.96
44.880	30.98	55.920	28.77	66.960	26.96
45.120	30.98	56.160	28.77	67.200	26.96
45.360	30.98	56.400	28.77	67.440	26.96
45.600	30.98	56.640	28.40	67.680	26.96
45.840	30.98	56.880	28.40	67.920	26.96
46.080	30.61	57.120	28.40	68.160	26.96
46.320	30.61	57.360	28.40	68.400	26.96
46.560	30.61	57.600	28.40	68.640	26.61
46.800	30.61	57.840	28.40	68.880	26.61
47.040	30.61	58.080	28.40	69.120	26.61
47.280	30.61	58.320	28.40	69.360	26.61
47.520	30.23	58.560	28.40	69.600	26.61
47.760	30.23	58.800	28.40	69.840	26.61
48.000	30.23	59.040	28.04	70.080	26.61
48.240	30.23	59.280	28.04	70.320	26.61
48.480	30.23	59.520	28.04	70.560	26.61
48.720	30.23	59.760	28.04	70.800	26.61
48.960	29.87	60.000	28.04	71.040	26.61
49.200	29.87	60.240	28.04	71.280	26.61
49.440	29.87	60.480	28.04	71.520	26.24
49.680	29.87	60.720	28.04	71.760	26.24
49.920	29.87	60.960	28.04		
50.160	29.87	61.200	28.04		
50.400	29.87	61.440	28.04		
50.640	29.49	61.680	27.68		
50.880	29.49	61.920	27.68		
51.120	29.49	62.160	27.68		

Trial 3 R-01-8.5B Water Temperature Profile

Ambient Temperature = 25.0°C

Time (hours)	Temperature (*C)	Time (hours)	Temperature (*C)	Time (hours)	Temperature (*C)	Time (hours)	Temperature (*C)
0.000	24.82	10.080	49.07	20.160	42.14	30.240	36.74
0.240	60.82	10.320	49.07	20.400	41.71	30.480	36.74
0.480	59.55	10.560	48.57	20.640	41.71	30.720	36.35
0.720	58.93	10.800	48.57	20.880	41.28	30.960	36.35
0.960	58.32	11.040	48.09	21.120	41.28	31.200	36.35
1.200	58.32	11.280	48.09	21.360	41.28	31.440	36.35
1.440	57.72	11.520	48.09	21.600	40.85	31.680	35.96
1.680	57.13	11.760	47.60	21.840	40.85	31.920	35.96
1.920	57.13	12.000	47.60	22.080	40.85	32.160	35.96
2.160	56.54	12.240	47.60	22.320	40.43	32.400	35.96
2.400	56.54	12.480	47.13	22.560	40.43	32.640	35.56
2.640	55.97	12.720	47.13	22.800	40.43	32.880	35.56
2.880	55.97	12.960	47.13	23.040	40.01	33.120	35.56
3.120	55.39	13.200	46.65	23.280	40.01	33.360	35.56
3.360	55.39	13.440	46.65	23.520	40.01	33.600	35.56
3.600	54.83	13.680	46.19	23.760	39.59	33.840	35.17
3.840	54.83	13.920	46.19	24.000	39.59	34.080	35.17
4.080	54.28	14.160	46.19	24.240	39.59	34.320	35.17
4.320	54.28	14.400	45.73	24.480	39.59	34.560	34.78
4.560	53.73	14.640	45.73	24.720	39.18	34.800	34.78
4.800	53.73	14.880	45.27	24.960	39.18	35.040	34.78
5.040	53.73	15.120	45.27	25.200	39.18	35.280	34.78
5.280	53.19	15.360	45.27	25.440	38.77	35.520	34.39
5.520	53.19	15.600	44.81	25.680	38.77	35.760	34.39
5.760	52.65	15.840	44.81	25.920	38.77	36.000	34.39
6.000	52.65	16.080	44.81	26.160	38.36	36.240	34.39
6.240	52.13	16.320	44.36	26.400	38.36	36.480	34.01
6.480	52.13	16.560	44.36	26.640	38.36	36.720	34.01
6.720	52.13	16.800	43.91	26.880	38.36	36.960	34.01
6.960	51.60	17.040	43.91	27.120	37.95	37.200	34.01
7.200	51.60	17.280	43.91	27.360	37.95	37.440	34.01
7.440	51.60	17.520	43.46	27.600	37.95	37.680	33.62
7.680	51.08	17.760	43.46	27.840	37.95	37.920	33.62
7.920	51.08	18.000	43.46	28.080	37.54	38.160	33.62
8.160	50.57	18.240	43.02	28.320	37.54	38.400	33.62
8.400	50.57	18.480	43.02	28.560	37.54	38.640	33.24
8.640	50.06	18.720	43.02	28.800	37.54	38.880	33.24
8.880	50.06	18.960	42.58	29.040	37.14	39.120	33.24
9.120	50.06	19.200	42.58	29.280	37.14	39.360	33.24
9.360	49.56	19.440	42.14	29.520	37.14	39.600	32.86
9.600	49.56	19.680	42.14	29.760	36.74	39.840	32.86
9.840	49.56	19.920	42.14	30.000	36.74	40.080	32.86

Time (hours)	Temperature (*C)	Time (hours)	Temperature (*C)	Time (hours)	Temperature (*C)
40.320	32.86	51.360	29.13	62.400	26.96
40.560	32.48	51.600	29.13	62.640	26.96
40.800	32.48	51.840	29.13	62.880	26.61
41.040	32.48	52.080	29.13	63.120	26.61
41.280	32.48	52.320	28.77	63.360	26.61
41.520	32.10	52.560	28.77	63.600	26.61
41.760	32.10	52.800	28.77	63.840	26.61
42.000	32.10	53.040	28.77	64.080	26.61
42.240	32.10	53.280	28.77	64.320	26.61
42.480	31.73	53.520	28.77	64.560	26.24
42.720	31.73	53.760	28.77	64.800	26.24
42.960	31.73	54.000	28.40	65.040	26.24
43.200	31.73	54.240	28.40	65.280	26.24
43.440	31.35	54.480	28.40	65.520	26.24
43.680	31.35	54.720	28.40	65.760	26.24
43.920	31.35	54.960	28.40	66.000	26.24
44.160	31.35	55.200	28.40	66.240	25.89
44.400	30.98	55.440	28.40	66.480	25.89
44.640	30.98	55.680	28.40	66.720	25.89
44.880	30.98	55.920	28.04	66.960	25.89
45.120	30.98	56.160	28.04	67.200	25.89
45.360	30.61	56.400	28.04	67.440	25.89
45.600	30.61	56.640	28.04	67.680	25.53
45.840	30.61	56.880	28.04	67.920	25.53
46.080	30.61	57.120	28.04	68.160	25.53
46.320	30.61	57.360	28.04	68.400	25.53
46.560	30.23	57.600	28.04	68.640	25.53
46.800	30.23	57.840	27.68	68.880	25.53
47.040	30.23	58.080	27.68	69.120	25.17
47.280	30.23	58.320	27.68	69.360	25.17
47.520	29.87	58.560	27.68	69.600	25.17
47.760	29.87	58.800	27.68	69.840	25.17
48.000	29.87	59.040	27.68	70.080	25.17
48.240	29.87	59.280	27.68	70.320	25.17
48.480	29.87	59.520	27.32	70.560	25.17
48.720	29.87	59.760	27.32	70.800	25.17
48.960	29.49	60.000	27.32	71.040	24.82
49.200	29.49	60.240	27.32	71.280	24.82
49.440	29.49	60.480	27.32	71.520	24.82
49.680	29.49	60.720	27.32	71.760	24.82
49.920	29.49	60.960	27.32		
50.160	29.49	61.200	26.96		
50.400	29.49	61.440	26.96		
50.640	29.13	61.680	26.96		
50.880	29.13	61.920	26.96		
51.120	29.13	62.160	26.96		

Trial 1 R-04-12 Water Temperature Profile

Ambient Temperature = 25.0°C

Time (days)	Temperature (*C)	Time (days)	Temperature (*C)	Time (days)	Temperature (*C)	Time (days)	Temperature (*C)
0.000	54.55	0.840	44.57	1.680	38.14	2.520	33.42
0.020	52.39	0.860	44.12	1.700	37.74	2.540	33.42
0.040	52.39	0.880	44.12	1.720	37.74	2.560	33.42
0.060	52.39	0.900	43.67	1.740	37.33	2.580	33.42
0.080	51.86	0.920	43.67	1.760	37.33	2.600	33.04
0.100	51.86	0.940	43.23	1.780	37.33	2.620	33.04
0.120	51.86	0.960	43.23	1.800	37.33	2.640	33.04
0.140	51.34	0.980	43.23	1.820	36.93	2.660	33.04
0.160	51.34	1.000	42.79	1.840	36.93	2.680	33.04
0.180	51.34	1.020	42.79	1.860	36.93	2.700	32.66
0.200	50.82	1.040	42.79	1.880	36.53	2.720	32.66
0.220	50.82	1.060	42.35	1.900	36.53	2.740	32.66
0.240	50.82	1.080	42.35	1.920	36.53	2.760	32.66
0.260	50.32	1.100	42.35	1.940	36.14	2.780	32.28
0.280	50.32	1.120	41.92	1.960	36.14	2.800	32.28
0.300	49.81	1.140	41.92	1.980	36.14	2.820	32.28
0.320	49.81	1.160	41.48	2.000	35.74	2.840	32.28
0.340	49.81	1.180	41.48	2.020	35.74	2.860	32.28
0.360	49.31	1.200	41.48	2.040	35.74	2.880	31.91
0.380	49.31	1.220	41.06	2.060	35.74	2.900	31.91
0.400	48.82	1.240	41.06	2.080	35.35	2.920	31.91
0.420	48.82	1.260	41.06	2.100	35.35	2.940	31.91
0.440	48.33	1.280	40.63	2.120	35.35	2.960	31.53
0.460	48.33	1.300	40.63	2.140	35.35	2.980	31.53
0.480	48.33	1.320	40.63	2.160	34.96	3.000	31.53
0.500	47.84	1.340	40.21	2.180	34.96	3.020	31.53
0.520	47.84	1.360	40.21	2.200	34.96	3.040	31.53
0.540	47.36	1.380	40.21	2.220	34.96	3.060	31.53
0.560	47.36	1.400	39.79	2.240	34.57	3.080	31.16
0.580	46.88	1.420	39.79	2.260	34.57	3.100	31.16
0.600	46.88	1.440	39.79	2.280	34.57	3.120	31.16
0.620	46.88	1.460	39.38	2.300	34.57	3.140	31.16
0.640	46.42	1.480	39.38	2.320	34.18	3.160	31.16
0.660	46.42	1.500	39.38	2.340	34.18	3.180	31.16
0.680	45.95	1.520	38.96	2.360	34.18	3.200	31.16
0.700	45.95	1.540	38.96	2.380	34.18	3.220	31.16
0.720	45.48	1.560	38.55	2.400	34.18	3.240	30.78
0.740	45.48	1.580	38.55	2.420	33.80	3.260	30.78
0.760	45.03	1.600	38.55	2.440	33.80	3.280	30.78
0.780	45.03	1.620	38.55	2.460	33.80	3.300	30.78
0.800	44.57	1.640	38.14	2.480	33.80	3.320	30.78
0.820	44.57	1.660	38.14	2.500	33.42	3.340	30.78

Time (days)	Temperature (*C)	Time (days)	Temperature (*C)	Time (days)	Temperature (*C)
3.360	30.78	4.280	28.21	5.200	26.77
3.380	30.41	4.300	28.21	5.220	26.77
3.400	30.41	4.320	28.21	5.240	26.77
3.420	30.41	4.340	28.21	5.260	26.77
3.440	30.41	4.360	28.21	5.280	26.77
3.460	30.41	4.380	28.21	5.300	26.77
3.480	30.41	4.400	28.21	5.320	26.77
3.500	30.41	4.420	28.21	5.340	26.77
3.520	30.04	4.440	28.21	5.360	26.77
3.540	30.04	4.460	28.21	5.380	26.77
3.560	30.04	4.480	27.85	5.400	26.77
3.580	30.04	4.500	27.85	5.420	26.77
3.600	30.04	4.520	27.85	5.440	26.41
3.620	30.04	4.540	27.85	5.460	26.41
3.640	29.67	4.560	27.85	5.480	26.41
3.660	29.67	4.580	27.85	5.500	26.41
3.680	29.67	4.600	27.85	5.520	26.41
3.700	29.67	4.620	27.85	5.540	26.41
3.720	29.67	4.640	27.85	5.560	26.41
3.740	29.67	4.660	27.85	5.580	26.41
3.760	29.67	4.680	27.49	5.600	26.41
3.780	29.31	4.700	27.49	5.620	26.41
3.800	29.31	4.720	27.49	5.640	26.41
3.820	29.31	4.740	27.49	5.660	26.41
3.840	29.31	4.760	27.49	5.680	26.41
3.860	29.31	4.780	27.49	5.700	26.41
3.880	29.31	4.800	27.49	5.720	26.41
3.900	28.94	4.820	27.49	5.740	26.06
3.920	28.94	4.840	27.49	5.760	26.06
3.940	28.94	4.860	27.13	5.780	26.06
3.960	28.94	4.880	27.13	5.800	26.06
3.980	28.94	4.900	27.13	5.820	26.06
4.000	28.94	4.920	27.13	5.840	26.06
4.020	28.94	4.940	27.13	5.860	26.06
4.040	28.58	4.960	27.13	5.880	26.06
4.060	28.58	4.980	27.13	5.900	26.06
4.080	28.58	5.000	27.13	5.920	26.06
4.100	28.58	5.020	27.13	5.940	26.06
4.120	28.58	5.040	27.13	5.960	25.70
4.140	28.58	5.060	26.77	5.980	25.70
4.160	28.58	5.080	26.77		
4.180	28.58	5.100	26.77		
4.200	28.58	5.120	26.77		
4.220	28.58	5.140	26.77		
4.240	28.58	5.160	26.77		
4.260	28.21	5.180	26.77		

Trial 1 R-07-12 Water Temperature Profile

Ambient Temperature = 25.0°C

Time (days)	Temperature (*C)	Time (days)	Temperature (*C)	Time (days)	Temperature (*C)	Time (days)	Temperature (*C)
0.000	62.13	0.840	49.56	1.680	43.02	2.520	37.54
0.020	58.93	0.860	49.56	1.700	42.58	2.540	37.54
0.040	58.32	0.880	49.07	1.720	42.58	2.560	37.54
0.060	57.72	0.900	49.07	1.740	42.58	2.580	37.54
0.080	57.13	0.920	49.07	1.760	42.58	2.600	37.14
0.100	57.13	0.940	48.57	1.780	42.14	2.620	37.14
0.120	56.54	0.960	48.57	1.800	42.14	2.640	37.14
0.140	56.54	0.980	48.09	1.820	42.14	2.660	37.14
0.160	56.54	1.000	48.09	1.840	41.71	2.680	37.14
0.180	55.97	1.020	48.09	1.860	41.71	2.700	36.74
0.200	55.97	1.040	47.60	1.880	41.71	2.720	36.74
0.220	55.39	1.060	47.60	1.900	41.28	2.740	36.74
0.240	55.39	1.080	47.60	1.920	41.28	2.760	36.35
0.260	54.83	1.100	47.13	1.940	41.28	2.780	36.35
0.280	54.83	1.120	47.13	1.960	40.85	2.800	36.35
0.300	54.83	1.140	47.13	1.980	40.85	2.820	36.35
0.320	54.28	1.160	46.65	2.000	40.85	2.840	35.96
0.340	54.28	1.180	46.65	2.020	40.85	2.860	35.96
0.360	54.28	1.200	46.65	2.040	40.43	2.880	35.96
0.380	53.73	1.220	46.19	2.060	40.43	2.900	35.96
0.400	53.73	1.240	46.19	2.080	40.43	2.920	35.56
0.420	53.19	1.260	46.19	2.100	40.01	2.940	35.56
0.440	53.19	1.280	45.73	2.120	40.01	2.960	35.56
0.460	53.19	1.300	45.73	2.140	40.01	2.980	35.56
0.480	52.65	1.320	45.73	2.160	40.01	3.000	35.17
0.500	52.65	1.340	45.27	2.180	39.59	3.020	35.17
0.520	52.65	1.360	45.27	2.200	39.59	3.040	35.17
0.540	52.13	1.380	45.27	2.220	39.59	3.060	35.17
0.560	52.13	1.400	44.81	2.240	39.18	3.080	34.78
0.580	52.13	1.420	44.81	2.260	39.18	3.100	34.78
0.600	51.60	1.440	44.81	2.280	39.18	3.120	34.78
0.620	51.60	1.460	44.36	2.300	39.18	3.140	34.78
0.640	51.60	1.480	44.36	2.320	38.77	3.160	34.39
0.660	51.08	1.500	44.36	2.340	38.77	3.180	34.39
0.680	51.08	1.520	43.91	2.360	38.77	3.200	34.39
0.700	50.57	1.540	43.91	2.380	38.36	3.220	34.39
0.720	50.57	1.560	43.91	2.400	38.36	3.240	34.01
0.740	50.57	1.580	43.46	2.420	38.36	3.260	34.01
0.760	50.06	1.600	43.46	2.440	38.36	3.280	34.01
0.780	50.06	1.620	43.46	2.460	37.95	3.300	34.01
0.800	50.06	1.640	43.02	2.480	37.95	3.320	34.01
0.820	49.56	1.660	43.02	2.500	37.95	3.340	33.62

Time (days)	Temperature (*C)	Time (days)	Temperature (*C)	Time (days)	Temperature (*C)
3.360	33.62	4.280	30.23	5.200	28.04
3.380	33.62	4.300	30.23	5.220	28.04
3.400	33.62	4.320	30.23	5.240	28.04
3.420	33.62	4.340	30.23	5.260	28.04
3.440	33.24	4.360	30.23	5.280	28.04
3.460	33.24	4.380	30.23	5.300	27.68
3.480	33.24	4.400	29.87	5.320	27.68
3.500	33.24	4.420	29.87	5.340	27.68
3.520	33.24	4.440	29.87	5.360	27.68
3.540	32.86	4.460	29.87	5.380	27.68
3.560	32.86	4.480	29.87	5.400	27.68
3.580	32.86	4.500	29.87	5.420	27.68
3.600	32.86	4.520	29.87	5.440	27.68
3.620	32.48	4.540	29.87	5.460	27.68
3.640	32.48	4.560	29.49	5.480	27.32
3.660	32.48	4.580	29.49	5.500	27.32
3.680	32.48	4.600	29.49	5.520	27.32
3.700	32.48	4.620	29.49	5.540	27.32
3.720	32.10	4.640	29.49	5.560	27.32
3.740	32.10	4.660	29.49		
3.760	32.10	4.680	29.49		
3.780	32.10	4.700	29.13		
3.800	32.10	4.720	29.13		
3.820	31.73	4.740	29.13		
3.840	31.73	4.760	29.13		
3.860	31.73	4.780	29.13		
3.880	31.73	4.800	29.13		
3.900	31.73	4.820	29.13		
3.920	31.35	4.840	28.77		
3.940	31.35	4.860	28.77		
3.960	31.35	4.880	28.77		
3.980	31.35	4.900	28.77		
4.000	31.35	4.920	28.77		
4.020	30.98	4.940	28.77		
4.040	30.98	4.960	28.40		
4.060	30.98	4.980	28.40		
4.080	30.98	5.000	28.40		
4.100	30.98	5.020	28.40		
4.120	30.98	5.040	28.40		
4.140	30.61	5.060	28.40		
4.160	30.61	5.080	28.40		
4.180	30.61	5.100	28.40		
4.200	30.61	5.120	28.04		
4.220	30.61	5.140	28.04		
4.240	30.61	5.160	28.04		
4.260	30.23	5.180	28.04		

Trial 1 R-10-12 Water Temperature Profile

Ambient Temperature = 25.0°C

Time (days)	Temperature (*C)	Time (days)	Temperature (*C)	Time (days)	Temperature (*C)	Time (days)	Temperature (*C)
0.000	67.83	0.840	50.06	1.680	43.02	2.520	38.36
0.020	64.18	0.860	49.56	1.700	43.02	2.540	38.36
0.040	63.48	0.880	49.56	1.720	43.02	2.560	37.95
0.060	62.80	0.900	49.56	1.740	43.02	2.580	37.95
0.080	61.47	0.920	49.07	1.760	42.58	2.600	37.95
0.100	60.82	0.940	49.07	1.780	42.58	2.620	37.95
0.120	60.18	0.960	48.57	1.800	42.58	2.640	37.54
0.140	59.55	0.980	48.57	1.820	42.14	2.660	37.54
0.160	59.55	1.000	48.57	1.840	42.14	2.680	37.54
0.180	58.93	1.020	48.09	1.860	42.14	2.700	37.54
0.200	58.32	1.040	48.09	1.880	42.14	2.720	37.14
0.220	57.72	1.060	47.60	1.900	41.71	2.740	37.14
0.240	57.72	1.080	47.60	1.920	41.71	2.760	37.14
0.260	57.13	1.100	47.60	1.940	41.28	2.780	36.74
0.280	57.13	1.120	47.60	1.960	41.28	2.800	36.74
0.300	56.54	1.140	47.13	1.980	41.28	2.820	36.74
0.320	55.97	1.160	47.13	2.000	40.85	2.840	36.74
0.340	55.97	1.180	46.65	2.020	40.85	2.860	36.74
0.360	55.97	1.200	46.65	2.040	40.85	2.880	36.35
0.380	55.39	1.220	46.65	2.060	40.85	2.900	36.35
0.400	54.83	1.240	46.19	2.080	40.43	2.920	36.35
0.420	54.83	1.260	46.19	2.100	40.43	2.940	36.35
0.440	54.28	1.280	46.19	2.120	40.43	2.960	35.96
0.460	54.28	1.300	45.73	2.140	40.43	2.980	35.96
0.480	53.73	1.320	45.73	2.160	40.01	3.000	35.96
0.500	53.73	1.340	45.73	2.180	40.01	3.020	35.96
0.520	53.19	1.360	45.27	2.200	40.01	3.040	35.56
0.540	53.19	1.380	45.27	2.220	40.01	3.060	35.56
0.560	53.19	1.400	45.27	2.240	39.59	3.080	35.56
0.580	52.65	1.420	44.81	2.260	39.59	3.100	35.56
0.600	52.65	1.440	44.81	2.280	39.59	3.120	35.56
0.620	52.13	1.460	44.81	2.300	39.59	3.140	35.17
0.640	52.13	1.480	44.36	2.320	39.18	3.160	35.17
0.660	51.60	1.500	44.36	2.340	39.18	3.180	35.17
0.680	51.60	1.520	44.36	2.360	39.18	3.200	35.17
0.700	51.60	1.540	44.36	2.380	38.77	3.220	35.17
0.720	51.08	1.560	43.91	2.400	38.77	3.240	34.78
0.740	51.08	1.580	43.91	2.420	38.77	3.260	34.78
0.760	50.57	1.600	43.91	2.440	38.77	3.280	34.78
0.780	50.57	1.620	43.46	2.460	38.77	3.300	34.78
0.800	50.57	1.640	43.46	2.480	38.36	3.320	34.78
0.820	50.06	1.660	43.46	2.500	38.36	3.340	34.39

Time (days)	Temperature (*C)	Time (days)	Temperature (*C)	Time (days)	Temperature (*C)
3.360	34.39	4.280	31.35	5.200	28.77
3.380	34.39	4.300	30.98	5.220	28.77
3.400	34.39	4.320	30.98	5.240	28.77
3.420	34.39	4.340	30.98	5.260	28.77
3.440	34.39	4.360	30.98	5.280	28.77
3.460	34.01	4.380	30.98	5.300	28.77
3.480	34.01	4.400	30.98	5.320	28.77
3.500	34.01	4.420	30.98	5.340	28.77
3.520	34.01	4.440	30.98	5.360	28.77
3.540	34.01	4.460	30.61	5.380	28.40
3.560	34.01	4.480	30.61	5.400	28.40
3.580	33.62	4.500	30.61	5.420	28.40
3.600	33.62	4.520	30.61	5.440	28.40
3.620	33.62	4.540	30.61	5.460	28.40
3.640	33.62	4.560	30.61	5.480	28.40
3.660	33.62	4.580	30.61	5.500	28.40
3.680	33.24	4.600	30.61	5.520	28.40
3.700	33.24	4.620	30.23	5.540	28.40
3.720	33.24	4.640	30.23	5.560	28.40
3.740	33.24	4.660	30.23	5.580	28.40
3.760	33.24	4.680	30.23	5.600	28.40
3.780	32.86	4.700	30.23	5.620	28.40
3.800	32.86	4.720	30.23	5.640	28.04
3.820	32.86	4.740	30.23	5.660	28.04
3.840	32.86	4.760	30.23	5.680	28.04
3.860	32.48	4.780	29.87	5.700	28.04
3.880	32.48	4.800	29.87	5.720	28.04
3.900	32.48	4.820	29.87	5.740	28.04
3.920	32.48	4.840	29.87	5.760	28.04
3.940	32.10	4.860	29.87	5.780	28.04
3.960	32.10	4.880	29.87	5.800	28.04
3.980	32.10	4.900	29.49	5.820	28.04
4.000	32.10	4.920	29.49	5.840	28.04
4.020	32.10	4.940	29.49	5.860	28.04
4.040	31.73	4.960	29.49	5.880	28.04
4.060	31.73	4.980	29.49	5.900	28.04
4.080	31.73	5.000	29.49	5.920	28.04
4.100	31.73	5.020	29.13	5.940	27.68
4.120	31.73	5.040	29.13	5.960	27.68
4.140	31.73	5.060	29.13	5.980	27.68
4.160	31.35	5.080	29.13		
4.180	31.35	5.100	29.13		
4.200	31.35	5.120	29.13		
4.220	31.35	5.140	29.13		
4.240	31.35	5.160	29.13		
4.260	31.35	5.180	28.77		

APPENDIX B: WATER TEMPERATURE PROFILES

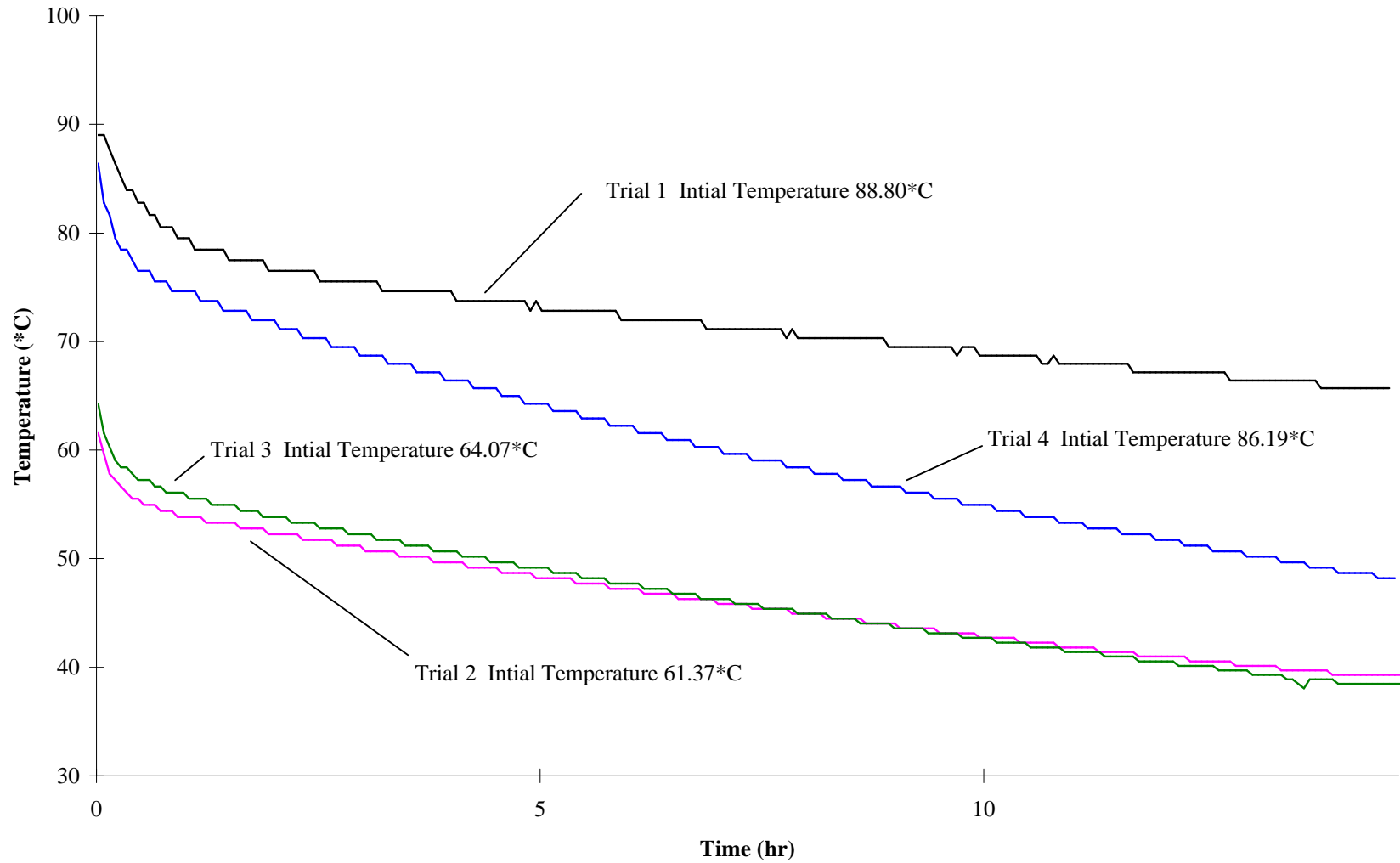

FIGURE B-1. Temperature Profile of Water in R-01-3.5B.

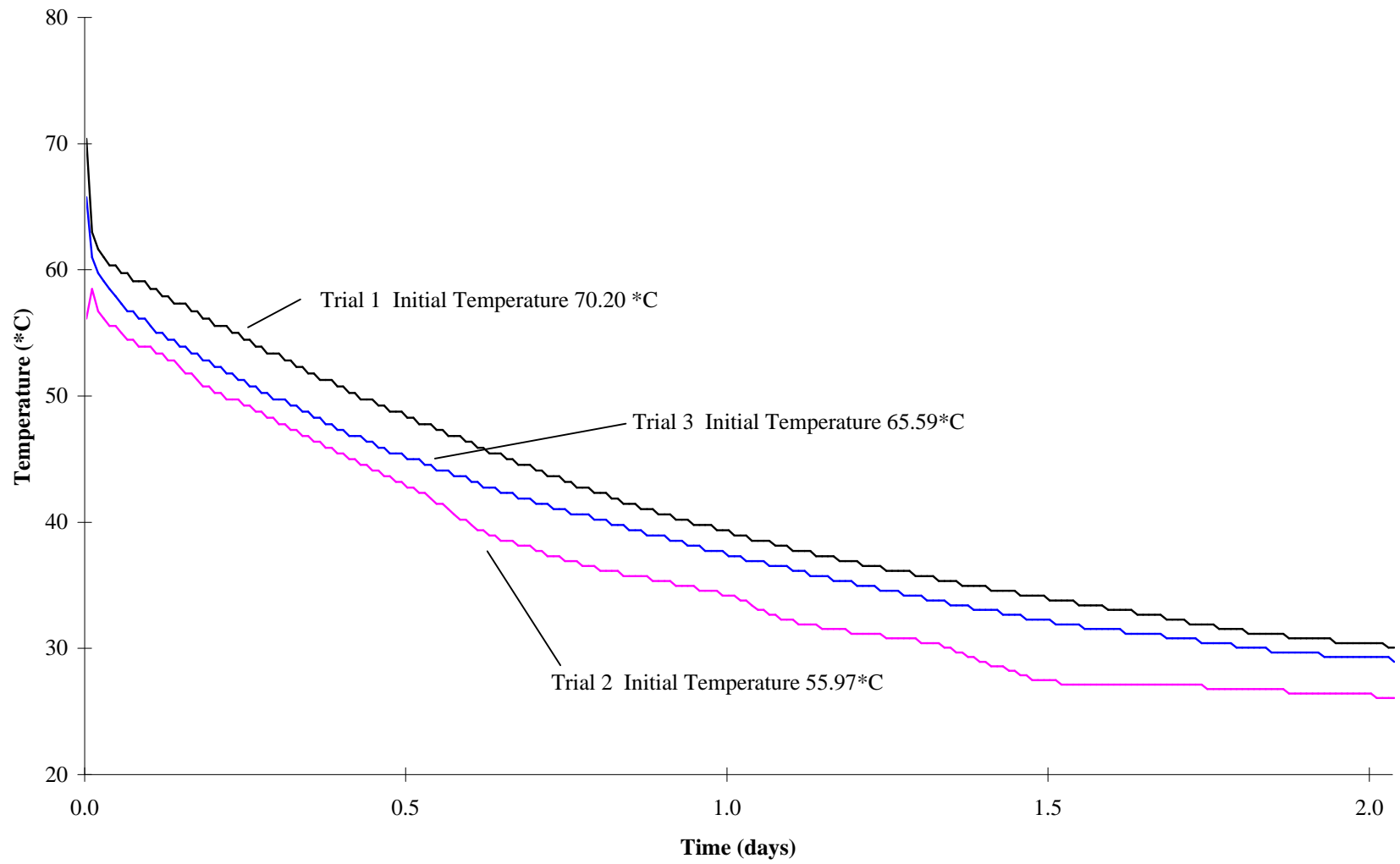

FIGURE B-2. Temperature Profile of Water in R-01-6.5A.

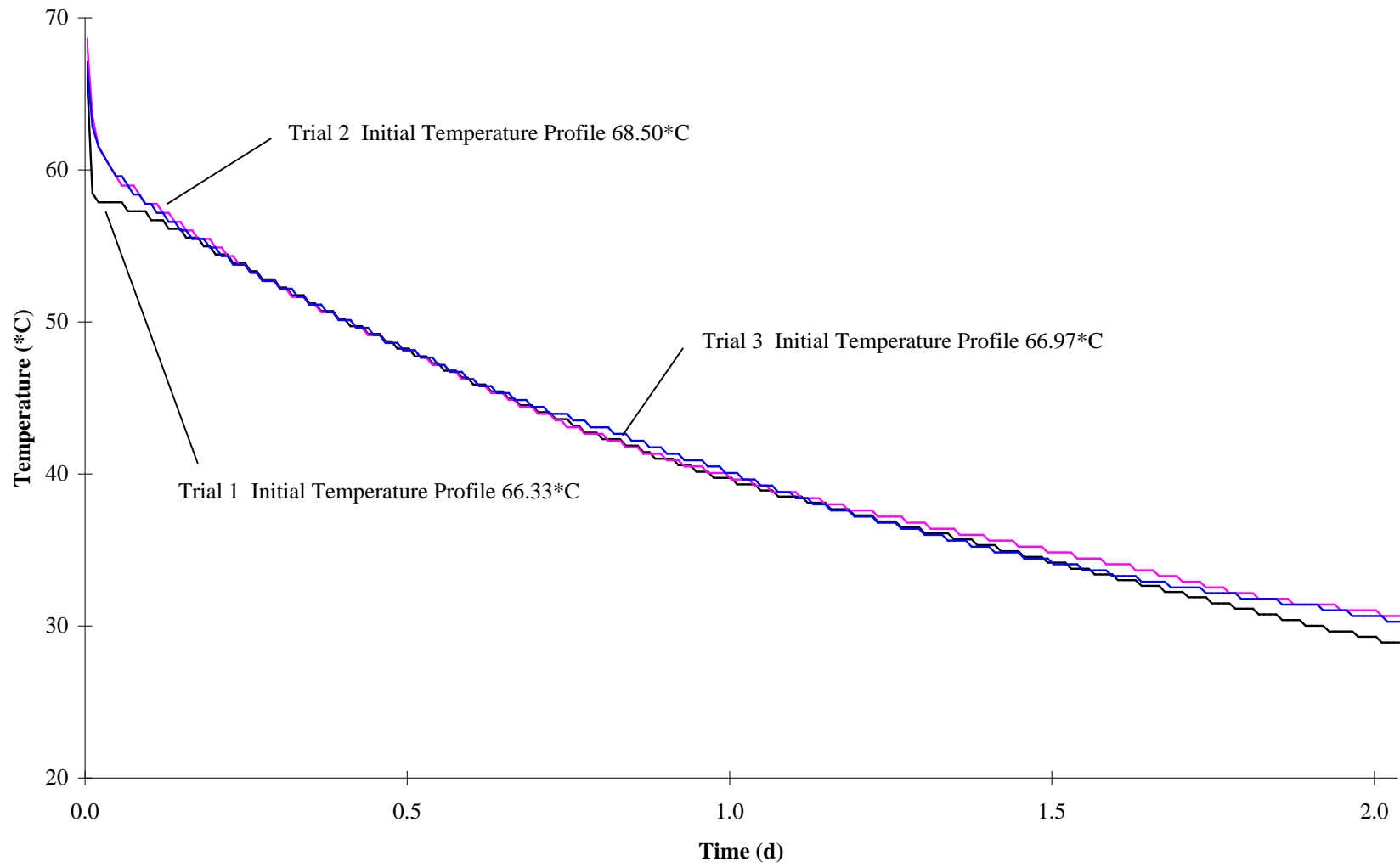

FIGURE B-3. Temperature Profile of Water in R-01-6.5B.

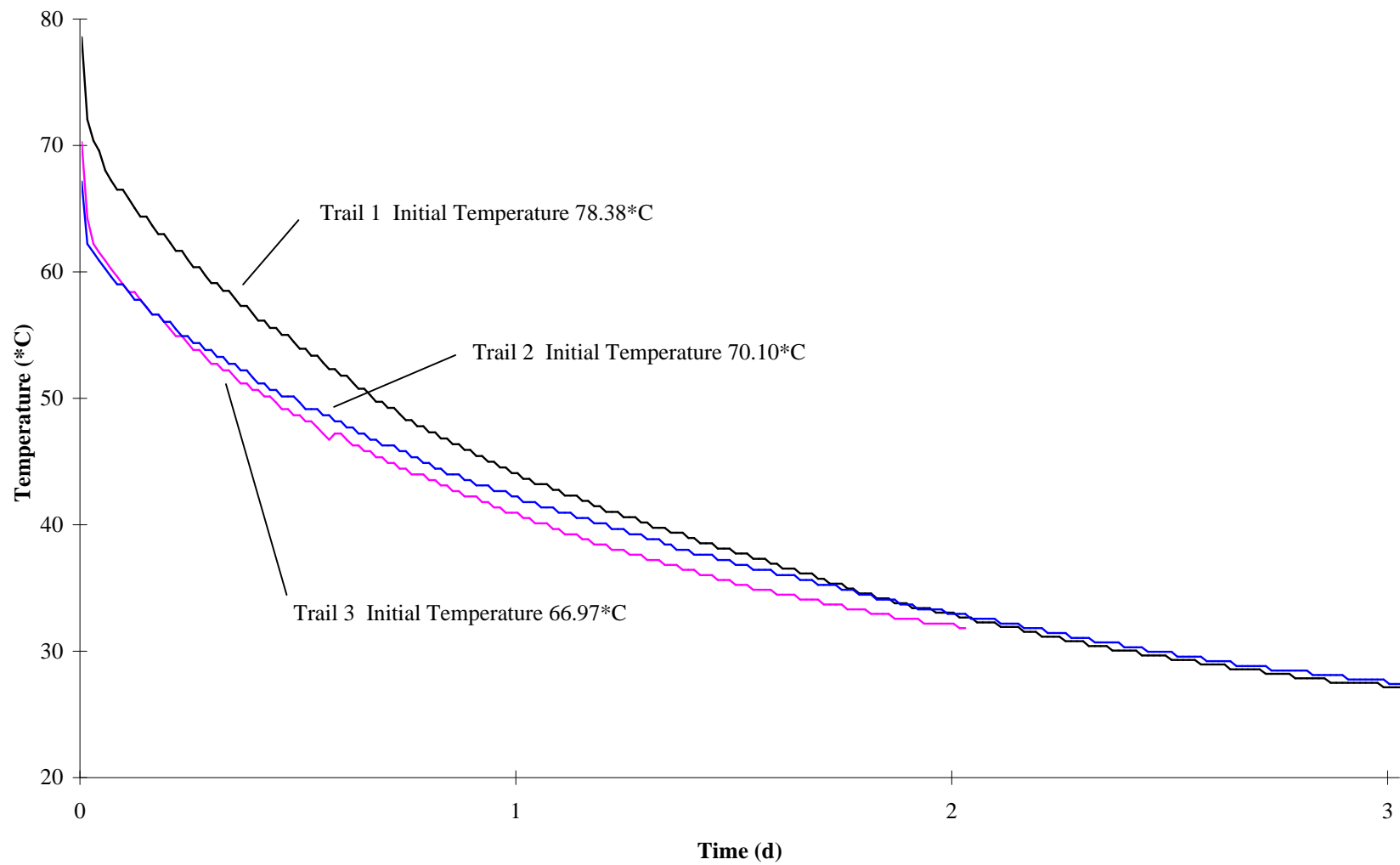

FIGURE B-4. Temperature Profile of Water in R-01-8.5A.

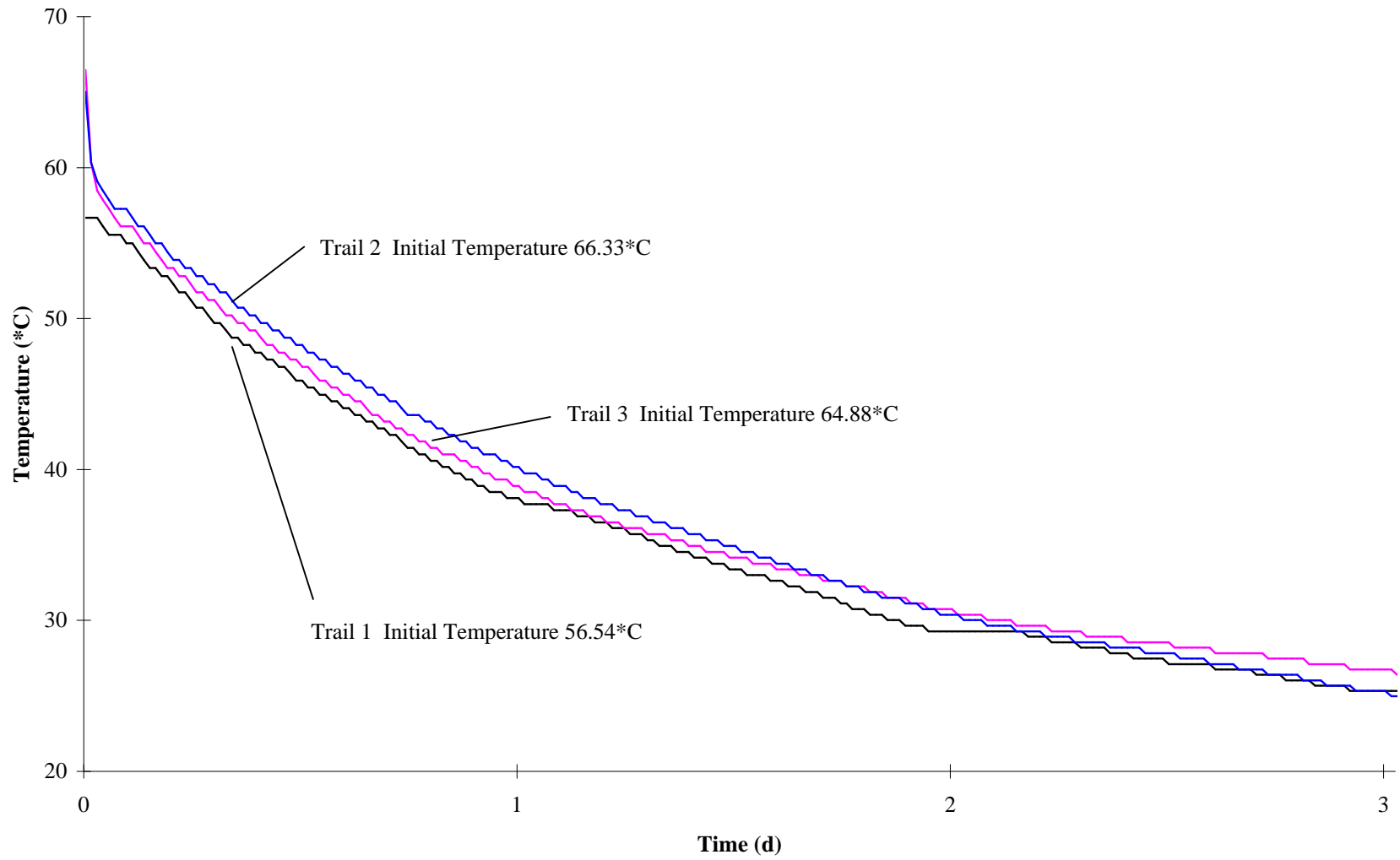

FIGURE B-5. Temperature Profile of Water in R-01-8.5B.

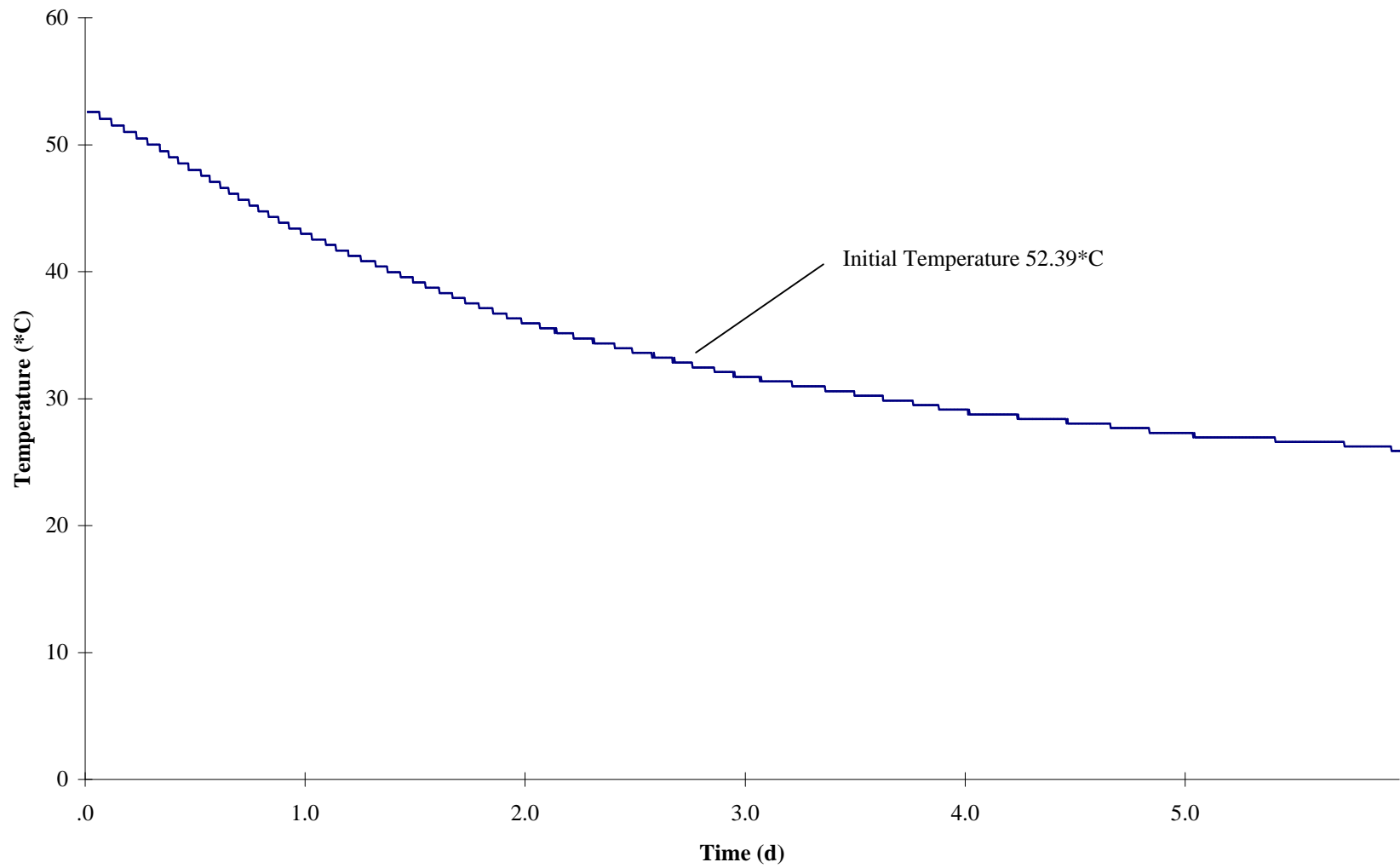

FIGURE B-6. Temperature Profile of Water in R-04-12.

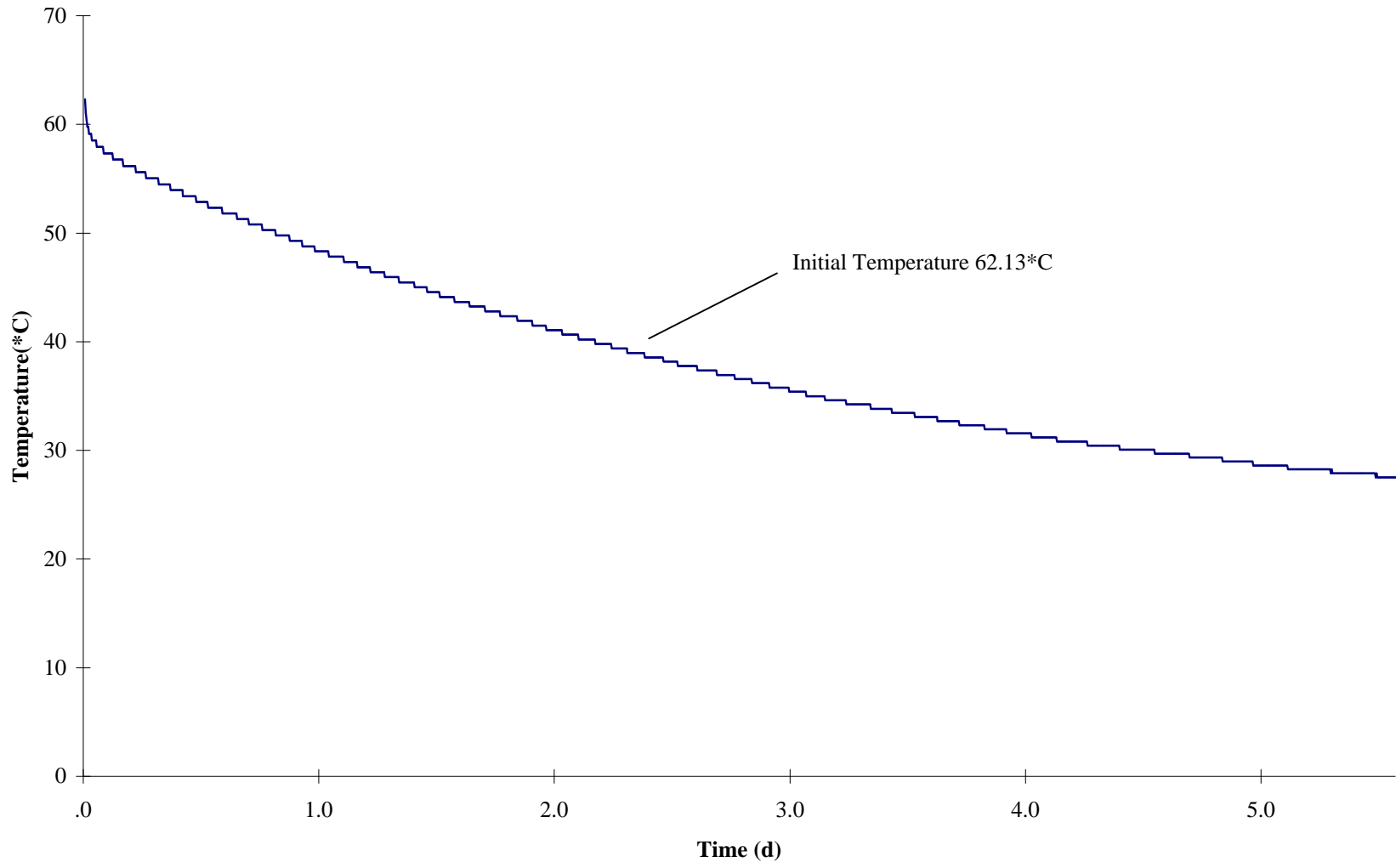

FIGURE B-7. Temperature Profile of Water in R-07-12.

APPENDIX C: LINEARIZATION OF THE WATER TEMPERATURE PROFILES

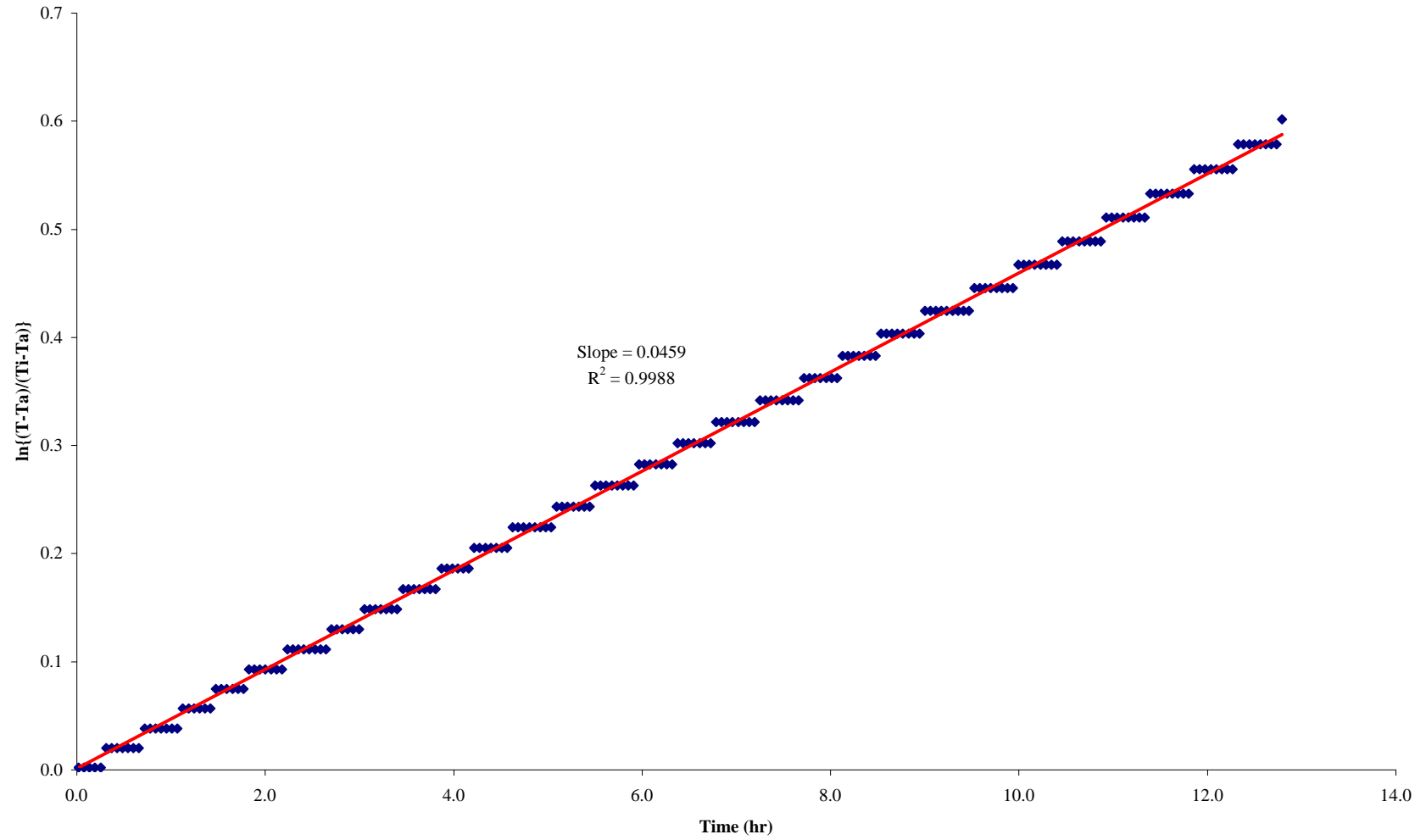

FIGURE C-1. Linearization of the Water Temperature Profile for R-01-3.5A Trial 2.

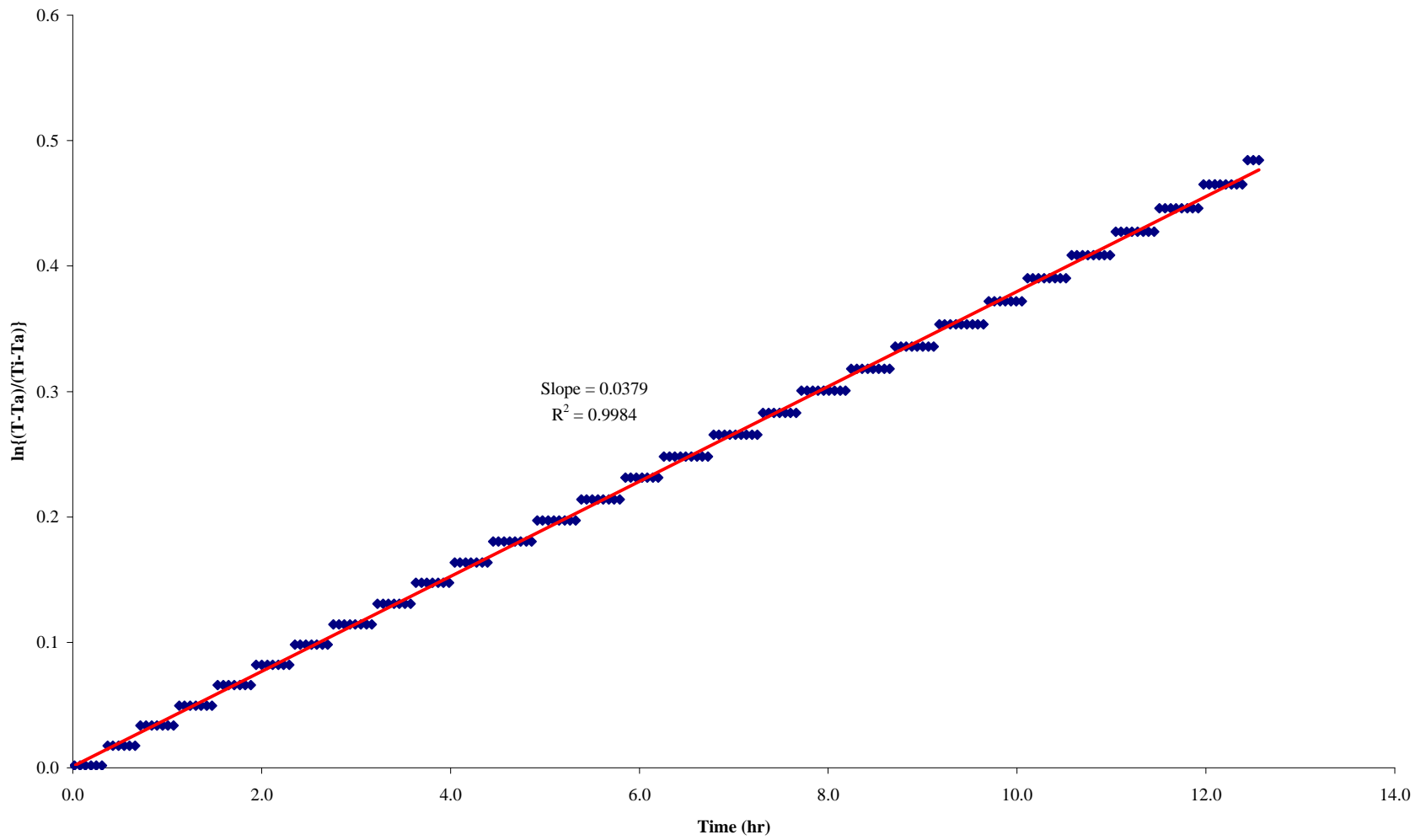

FIGURE C-2. Linearization of the Water Temperature Profile for R-01-3.5A Trial 3.

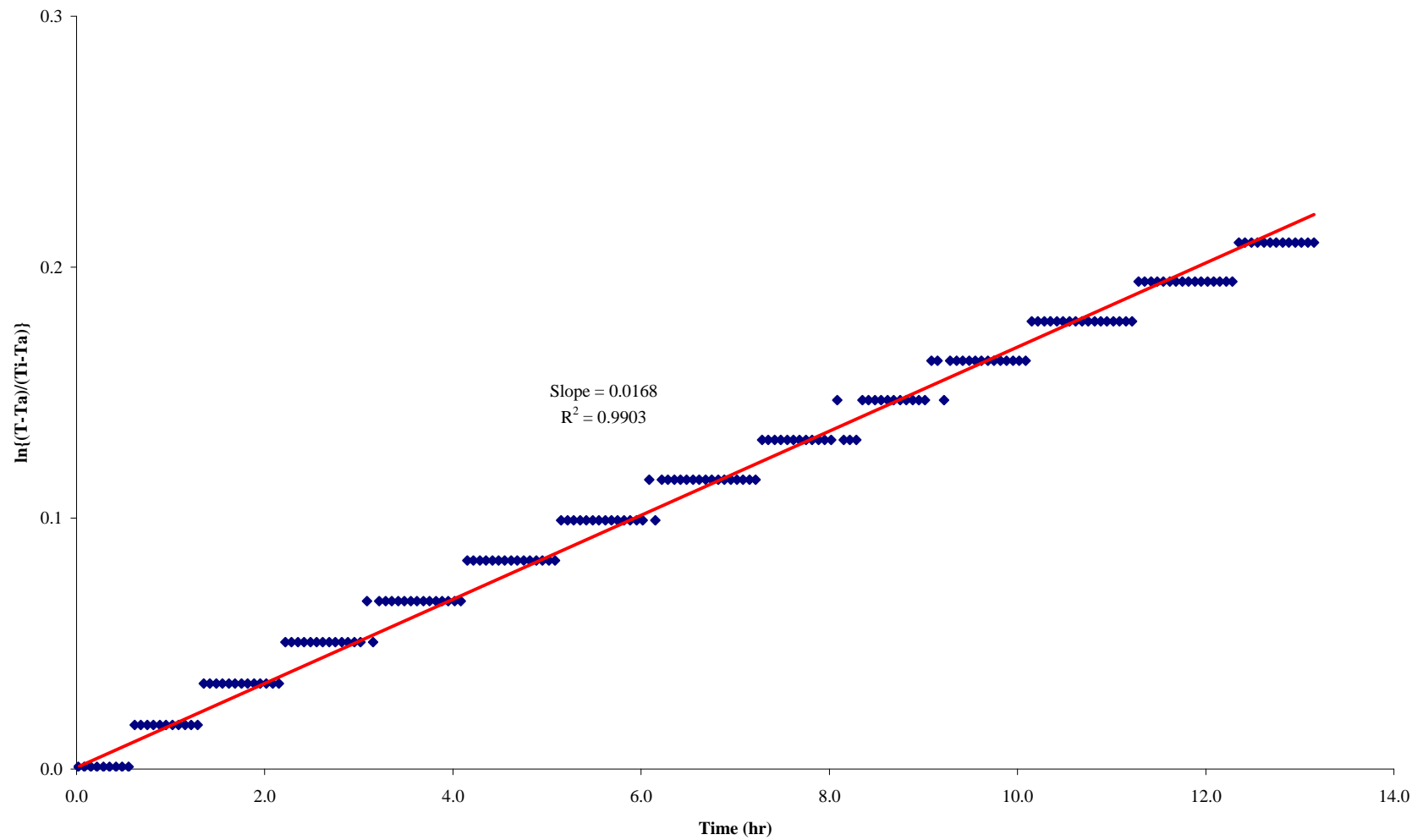

FIGURE C-3. Linearization of the Water Temperature Profile for R-01-3.5B Trial 1.

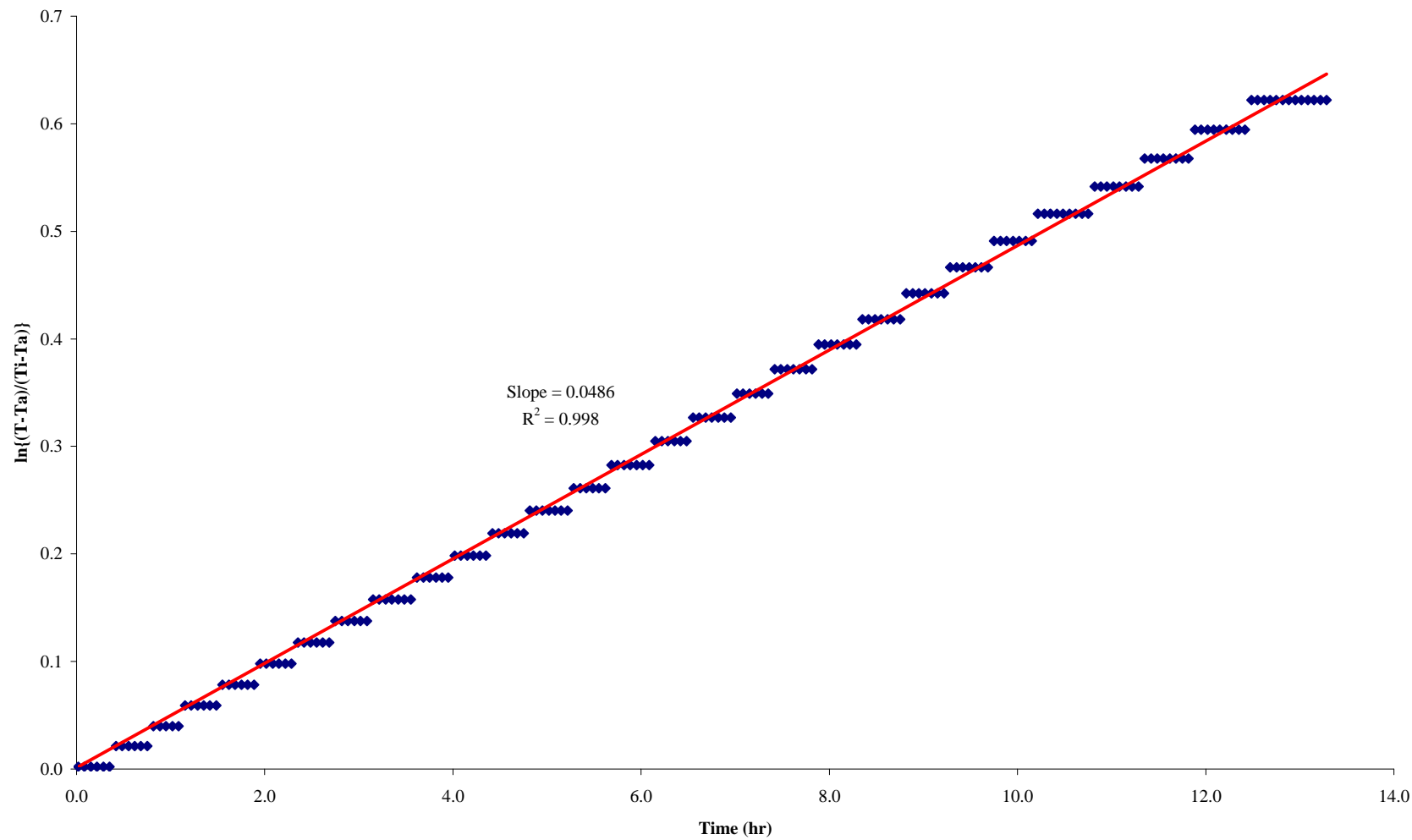

FIGURE C-4. Linearization of the Water Temperature Profile for R-01-3.5B Trial 2.

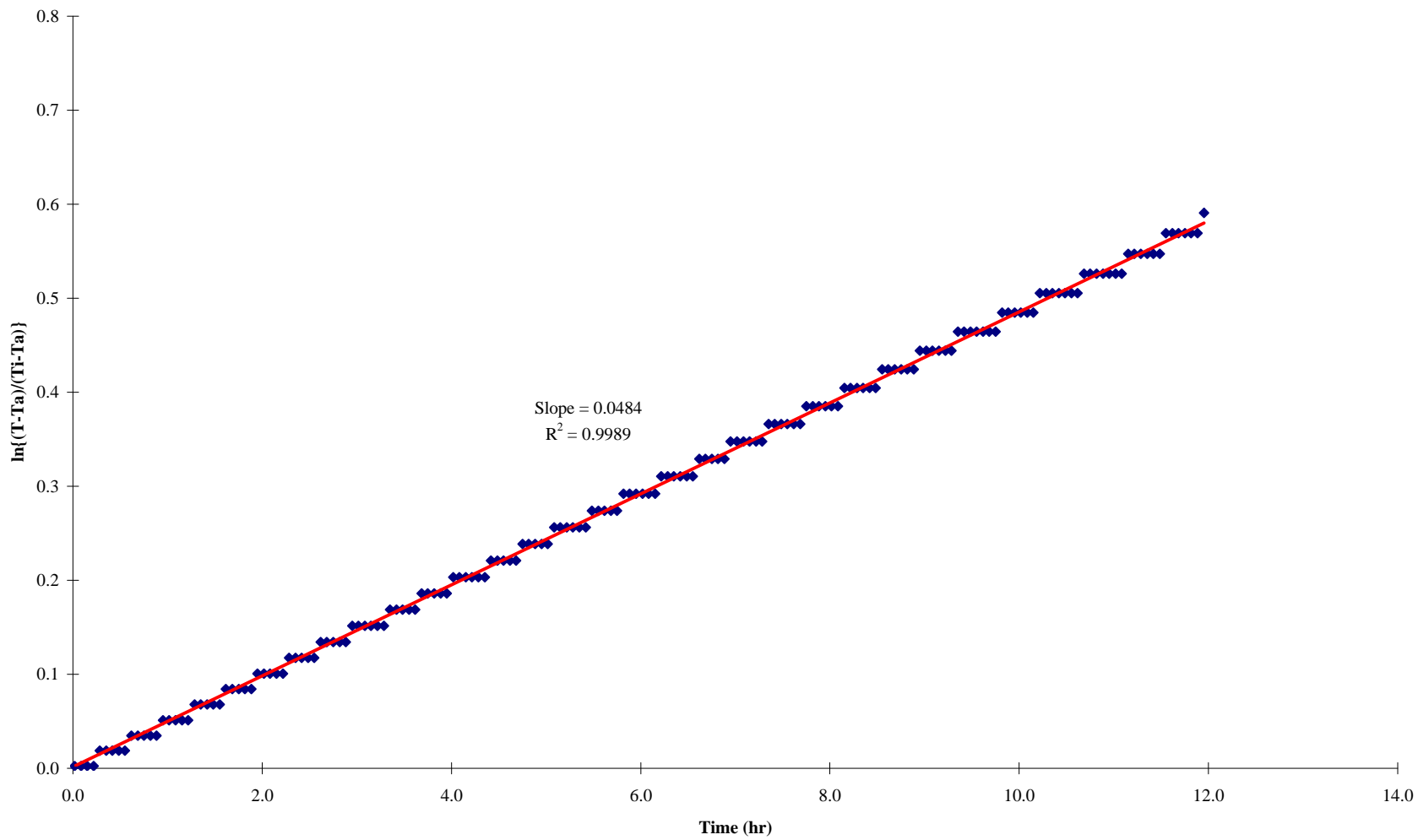

FIGURE C-5. Linearization of the Water Temperature Profile for R-01-3.5B Trial 3.

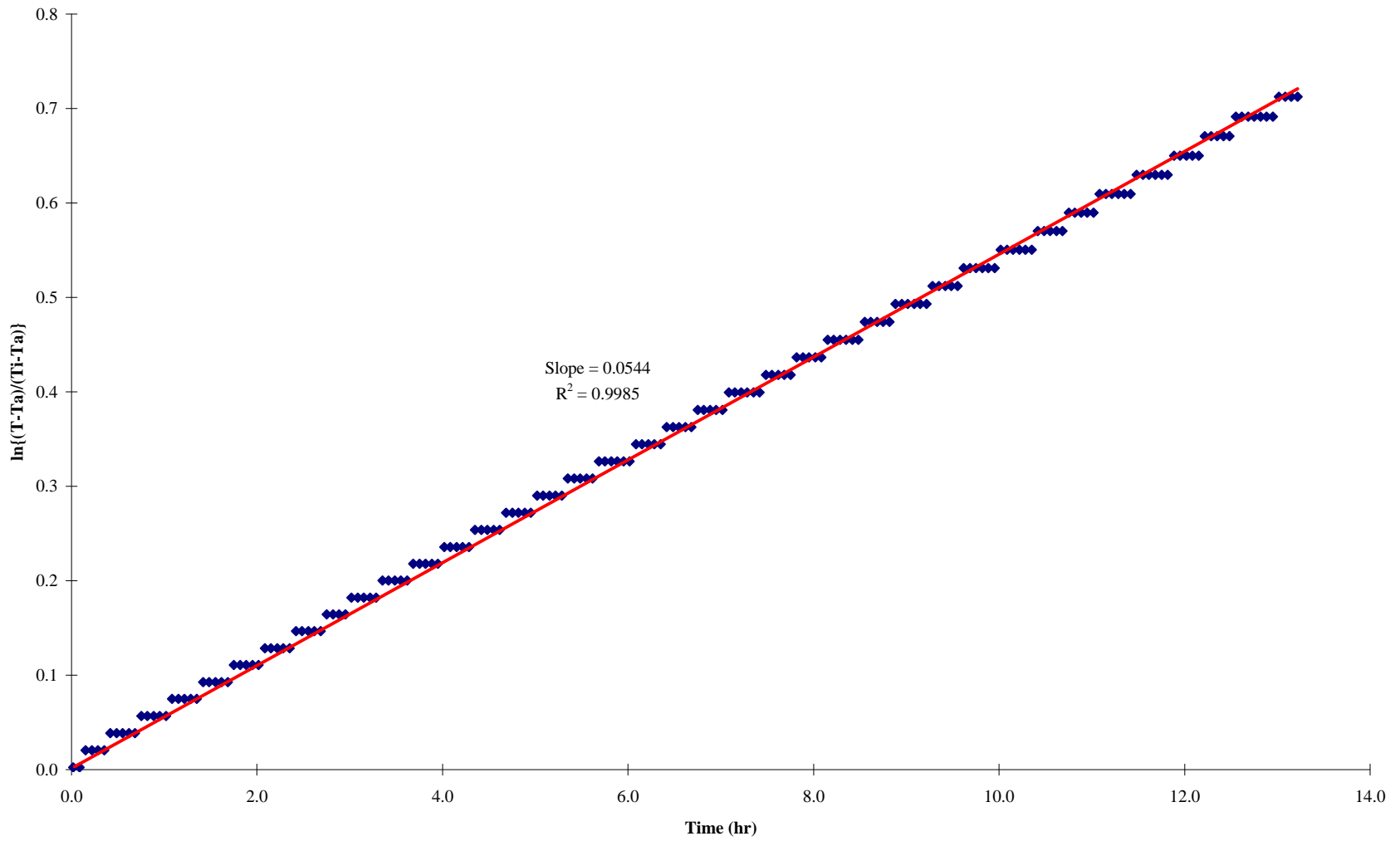

FIGURE C-6. Linearization of the Water Temperature Profile for R-01-3.5B Trial 4.

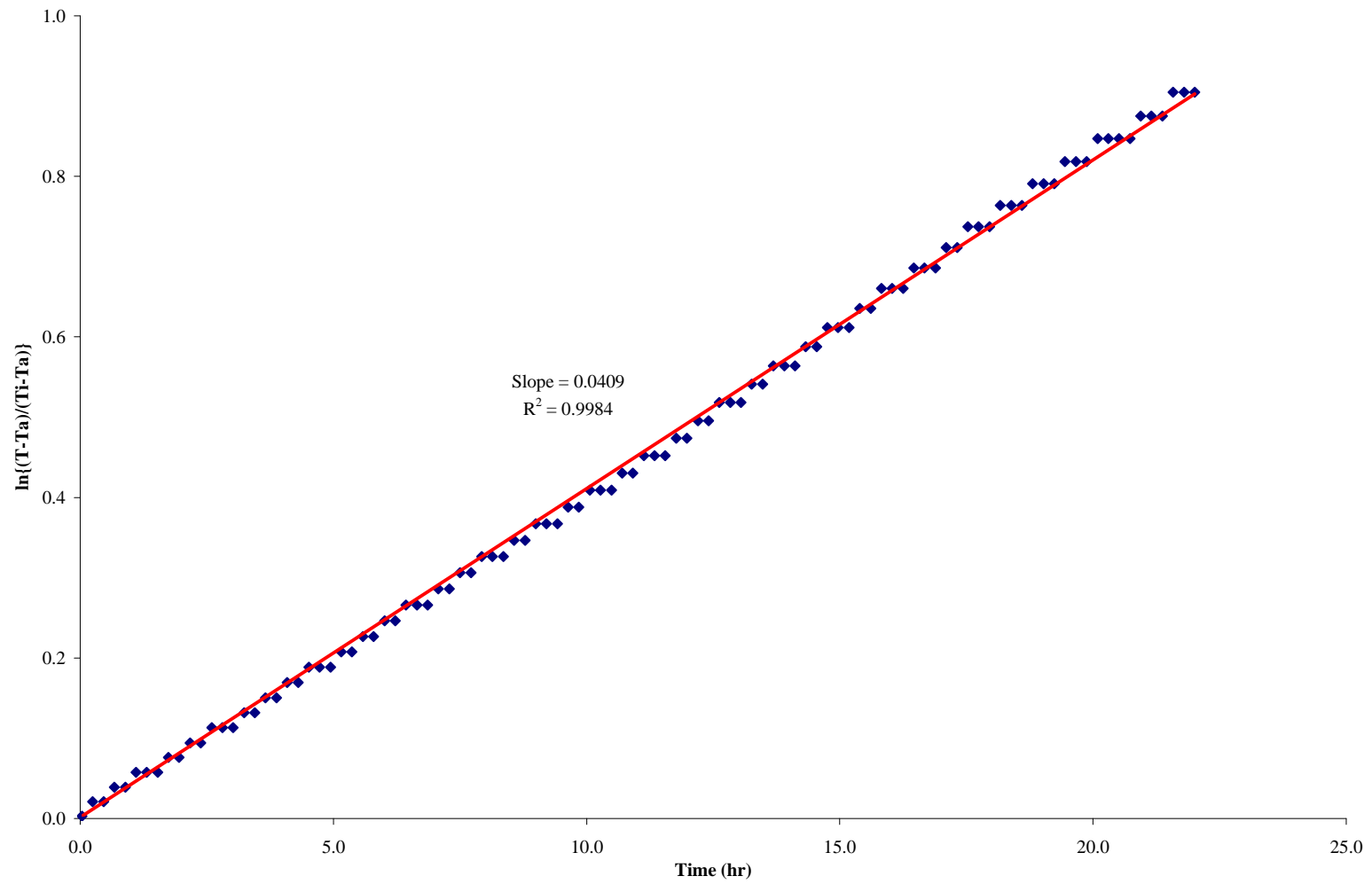

FIGURE C-7. Linearization of the Water Temperature Profile for R-01-6.5A Trial 1.

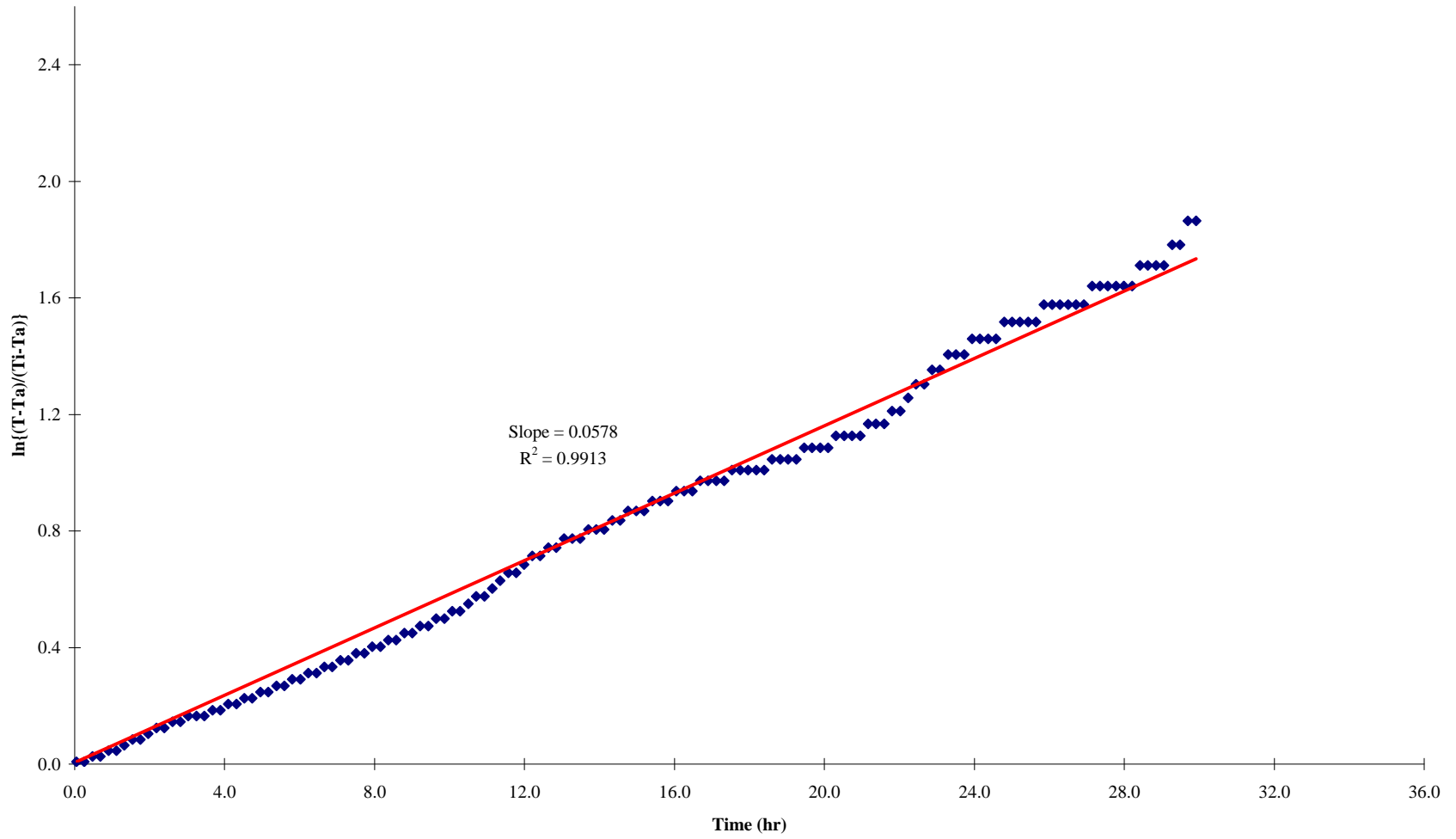

FIGURE C-8. Linearization of the Water Temperature Profile for R-01-6.5A Trial 2.

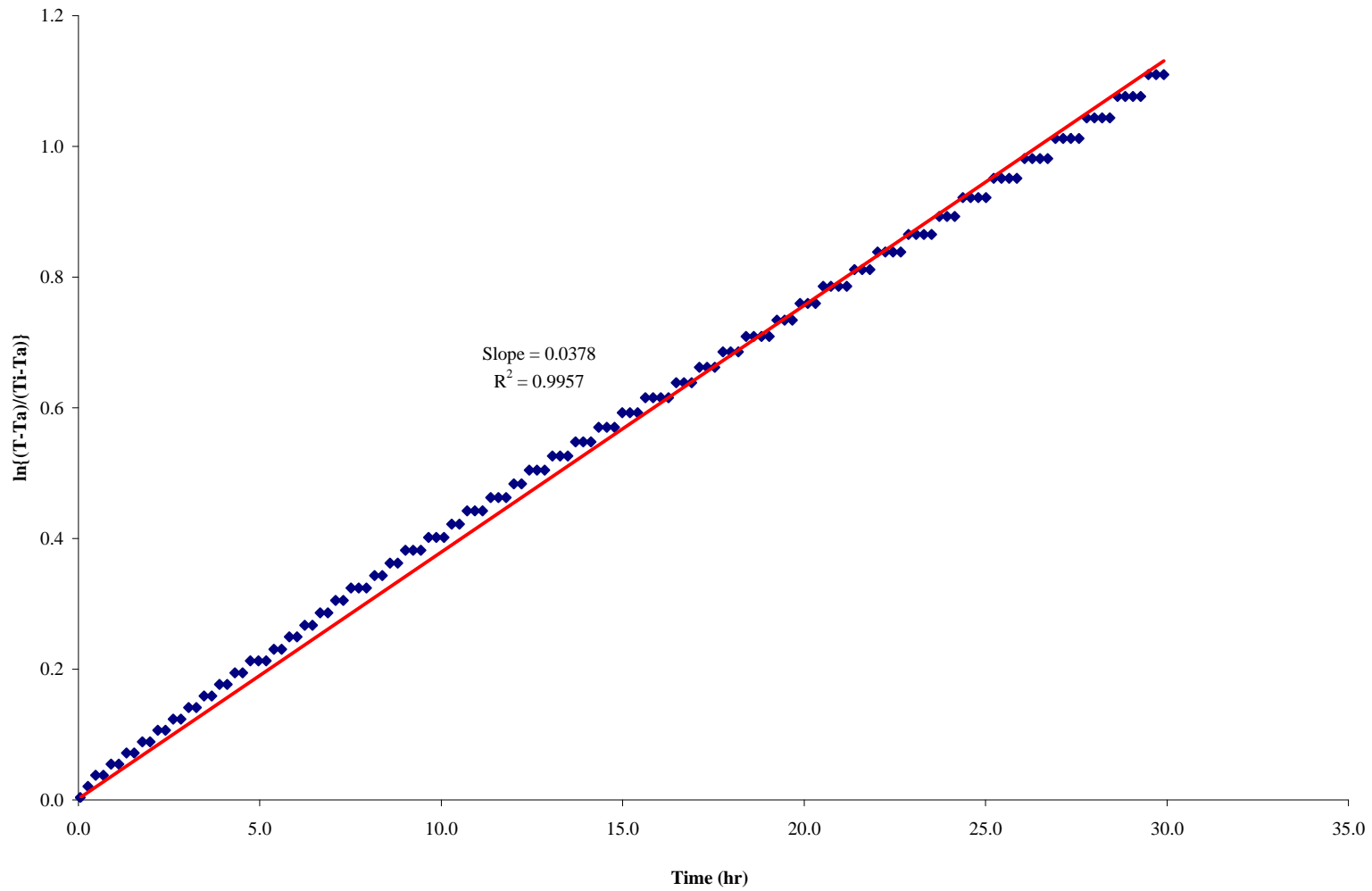

FIGURE C-9. Linearization of the Water Temperature Profile for R-01-6.5A Trial 3.

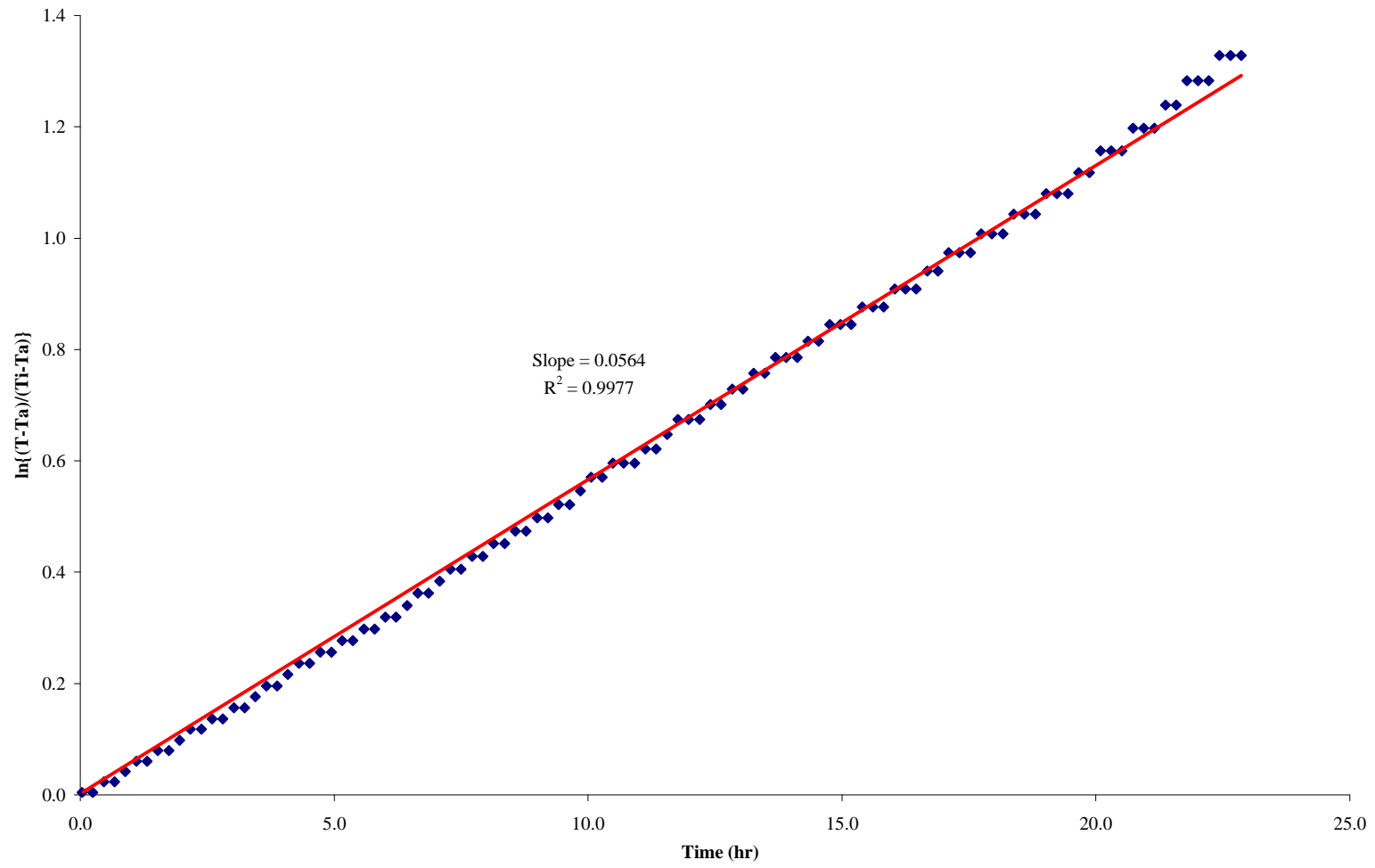

FIGURE C-10. Linearization of the Water Temperature Profile for R-01-6.5B Trial 1.

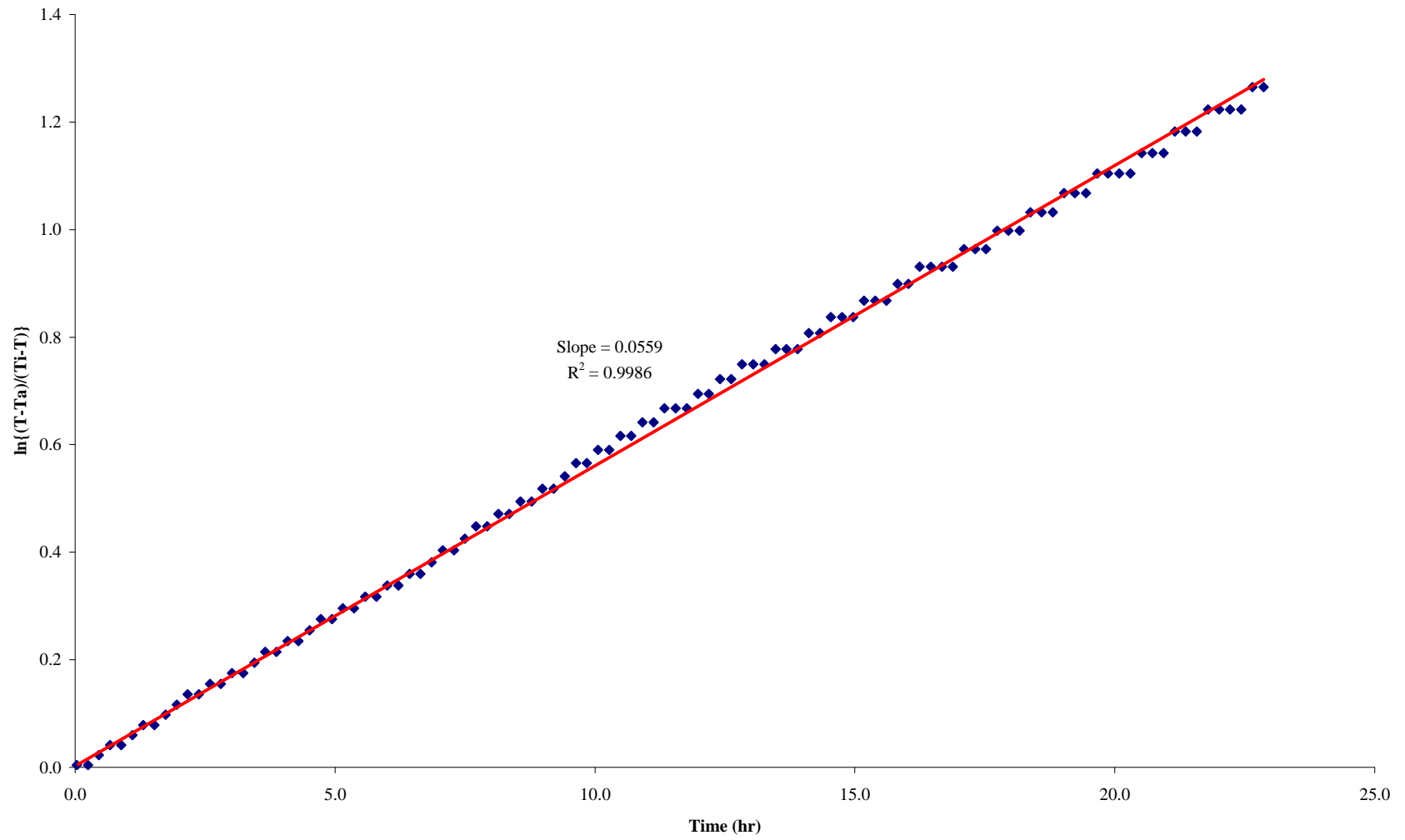

FIGURE C-11. Linearization of the Water Temperature Profile for R-01-6.5B Trial 2.

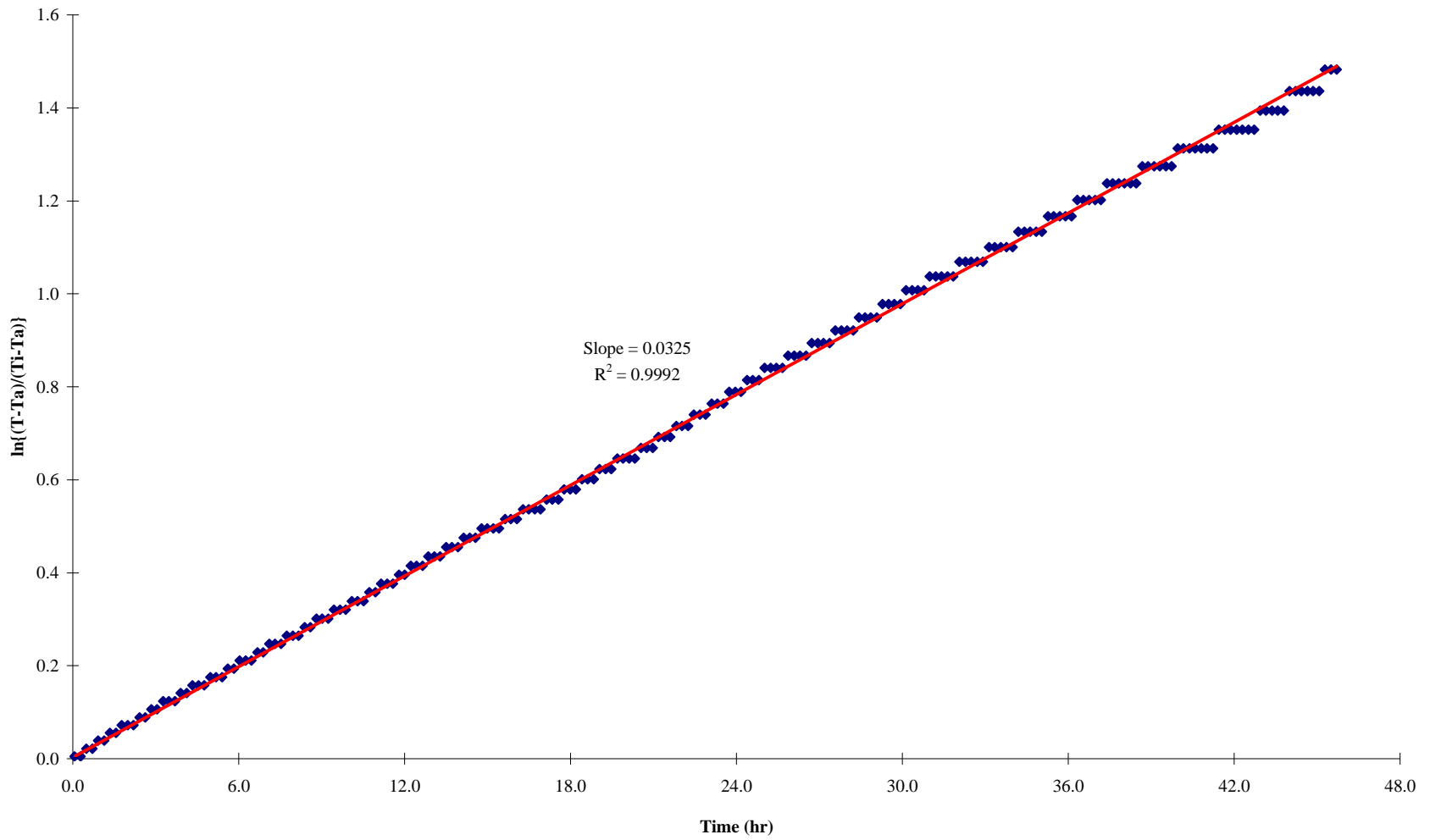

FIGURE C-12. Linearization of the Water Temperature Profile for R-01-6.5B Trial 3.

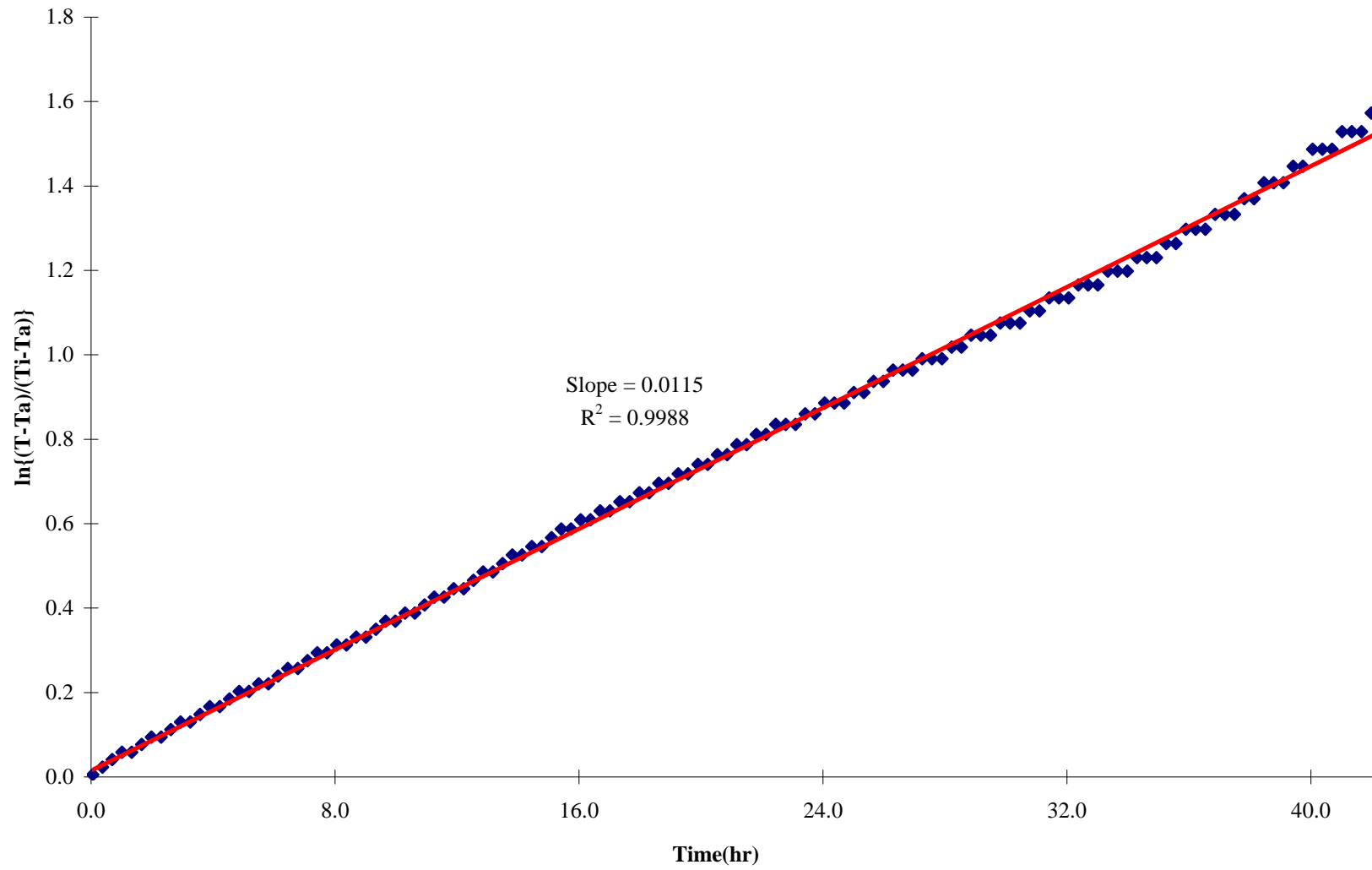

FIGURE C-13. Linearization of the Water Temperature Profile for R-01-8.5A Trial 1.

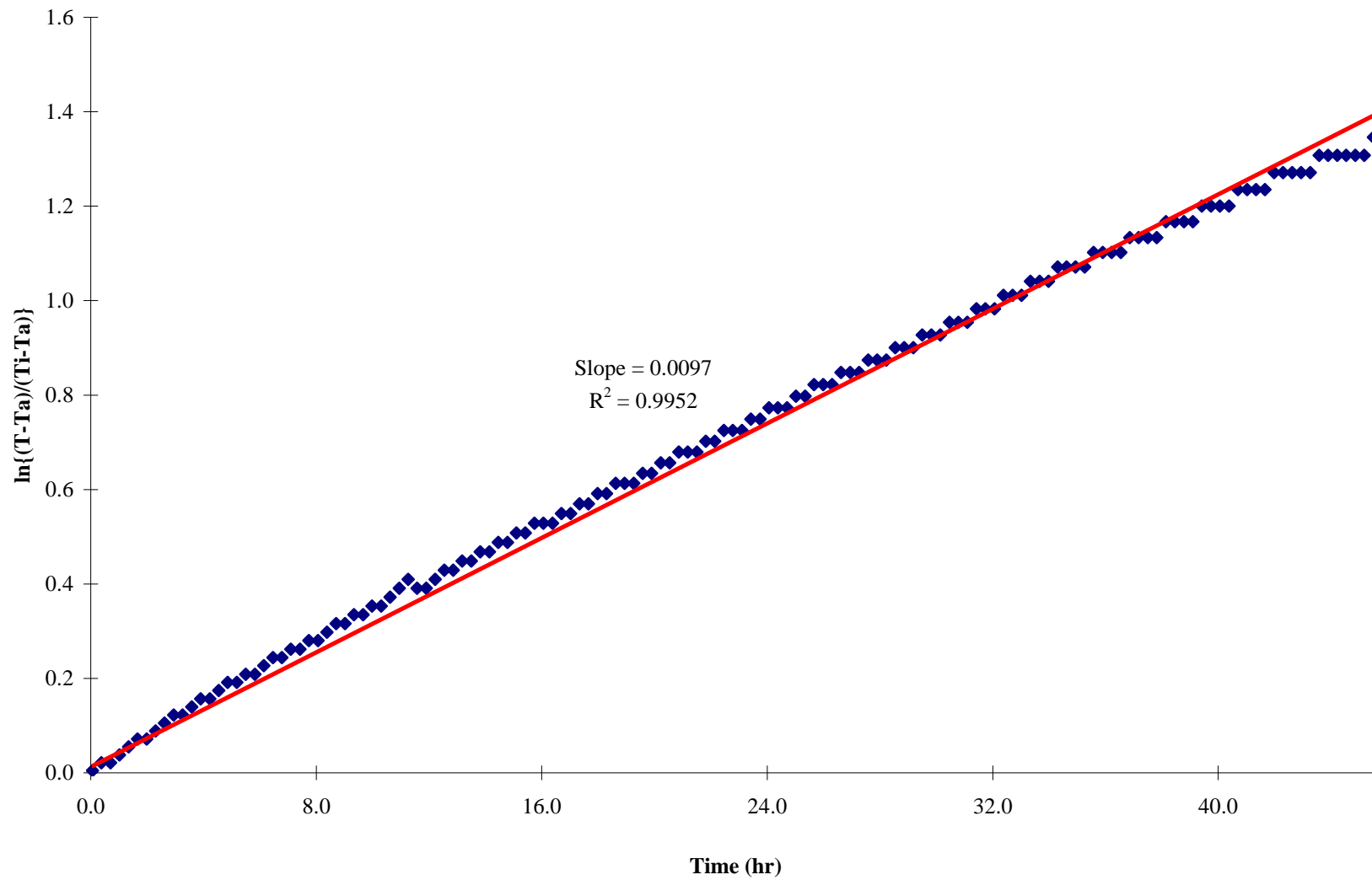

FIGURE C-14. Linearization of Water Temperature Profile for R-01-8.5A Trial 2.

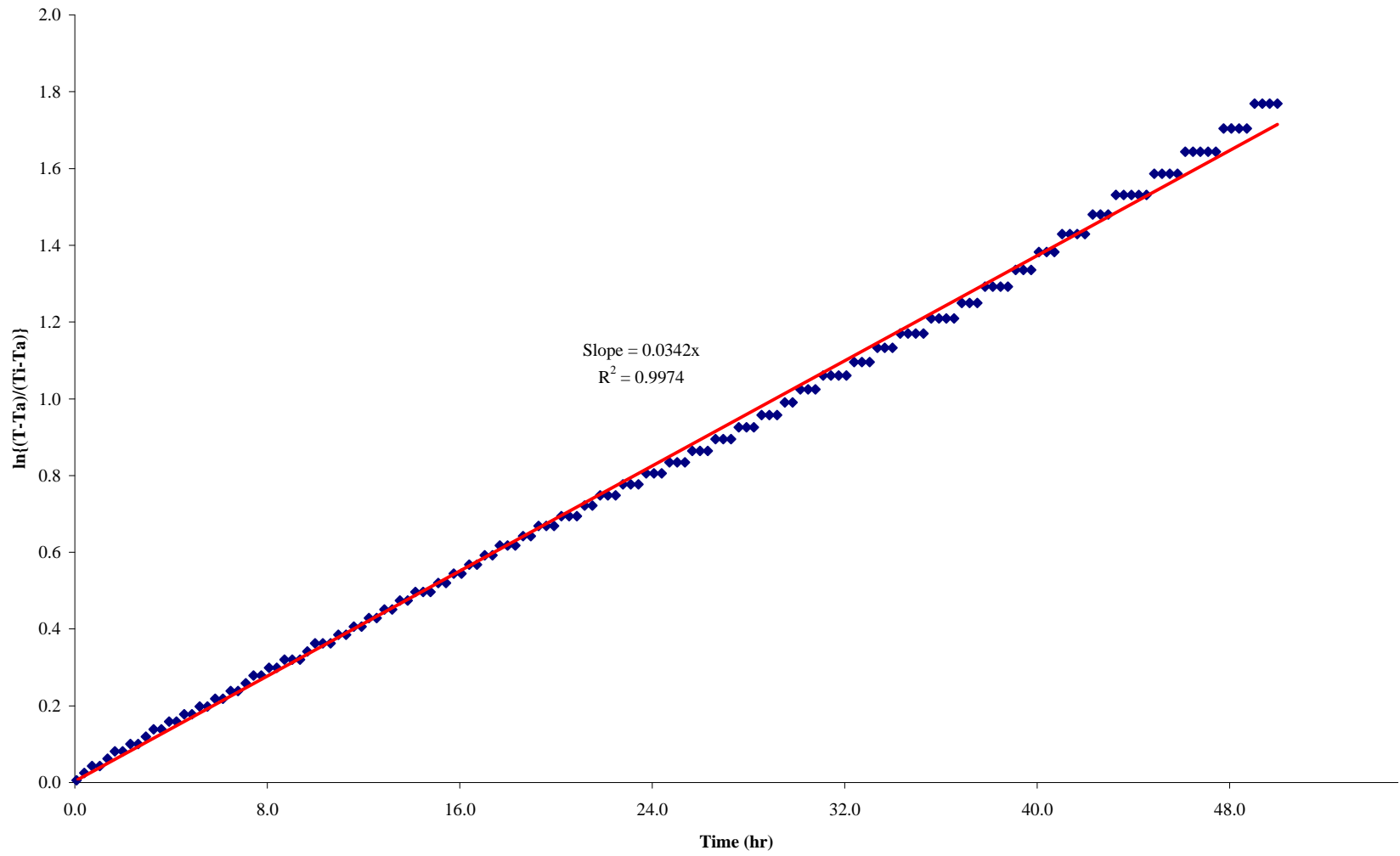

FIGURE C-15. Linearization of the Water Temperature Profile for R-01-8.5A Trial 3.

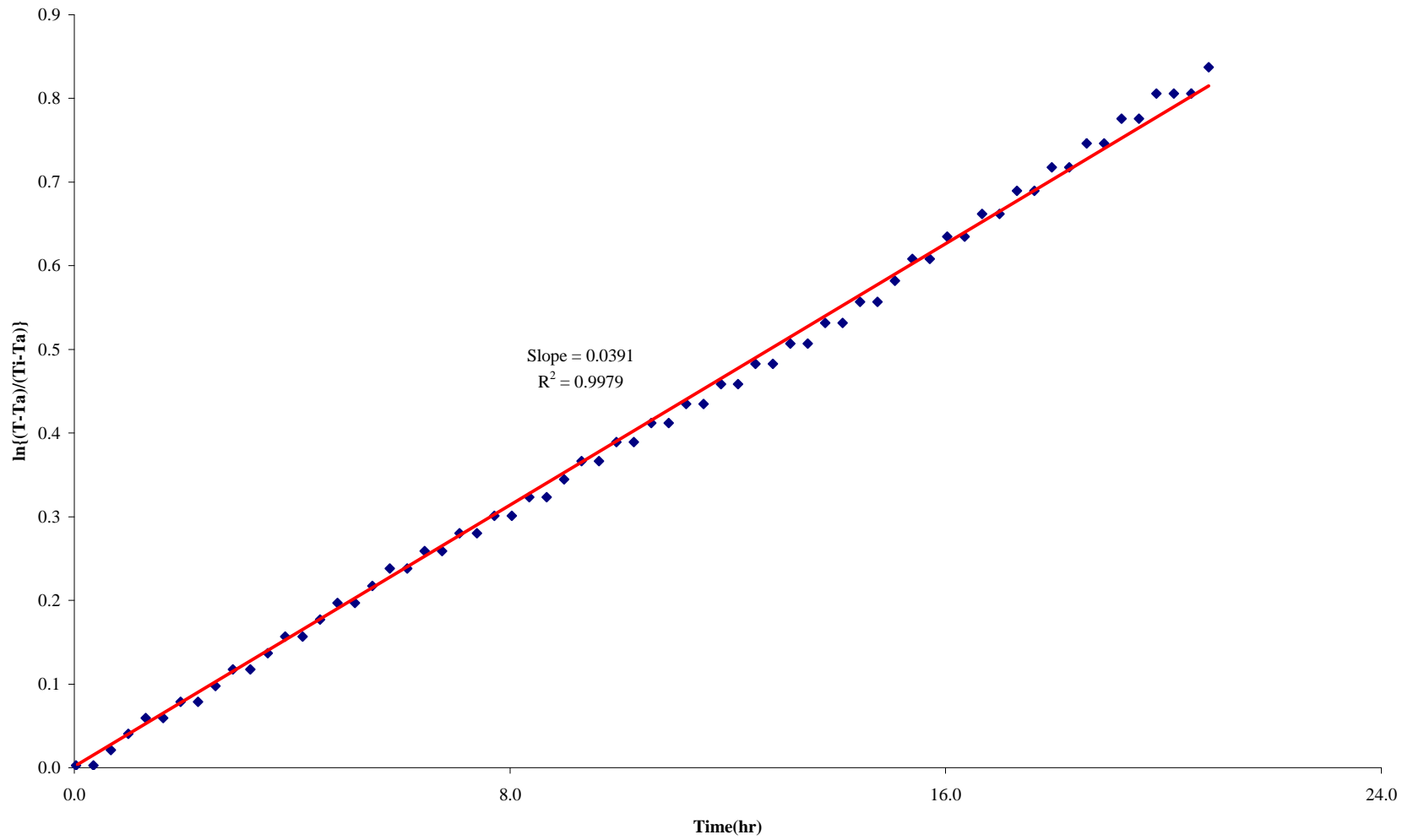

FIGURE C-16. Linearization of the Water Temperature Profile for R-01-8.5B Trial 1.

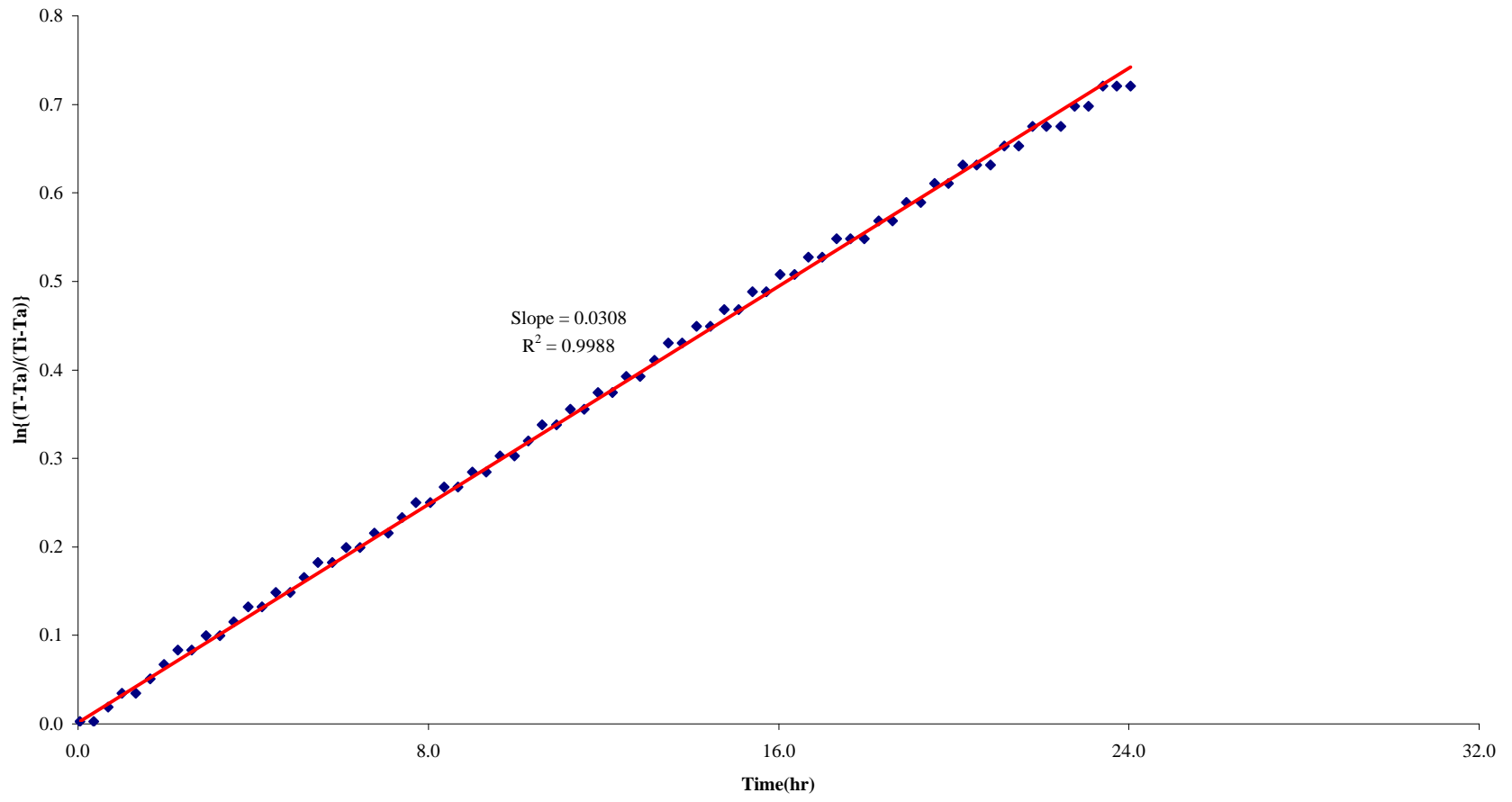

FIGURE C-17. Linearization of the Water Temperature Profile for R-01-8.5B Trial 2.

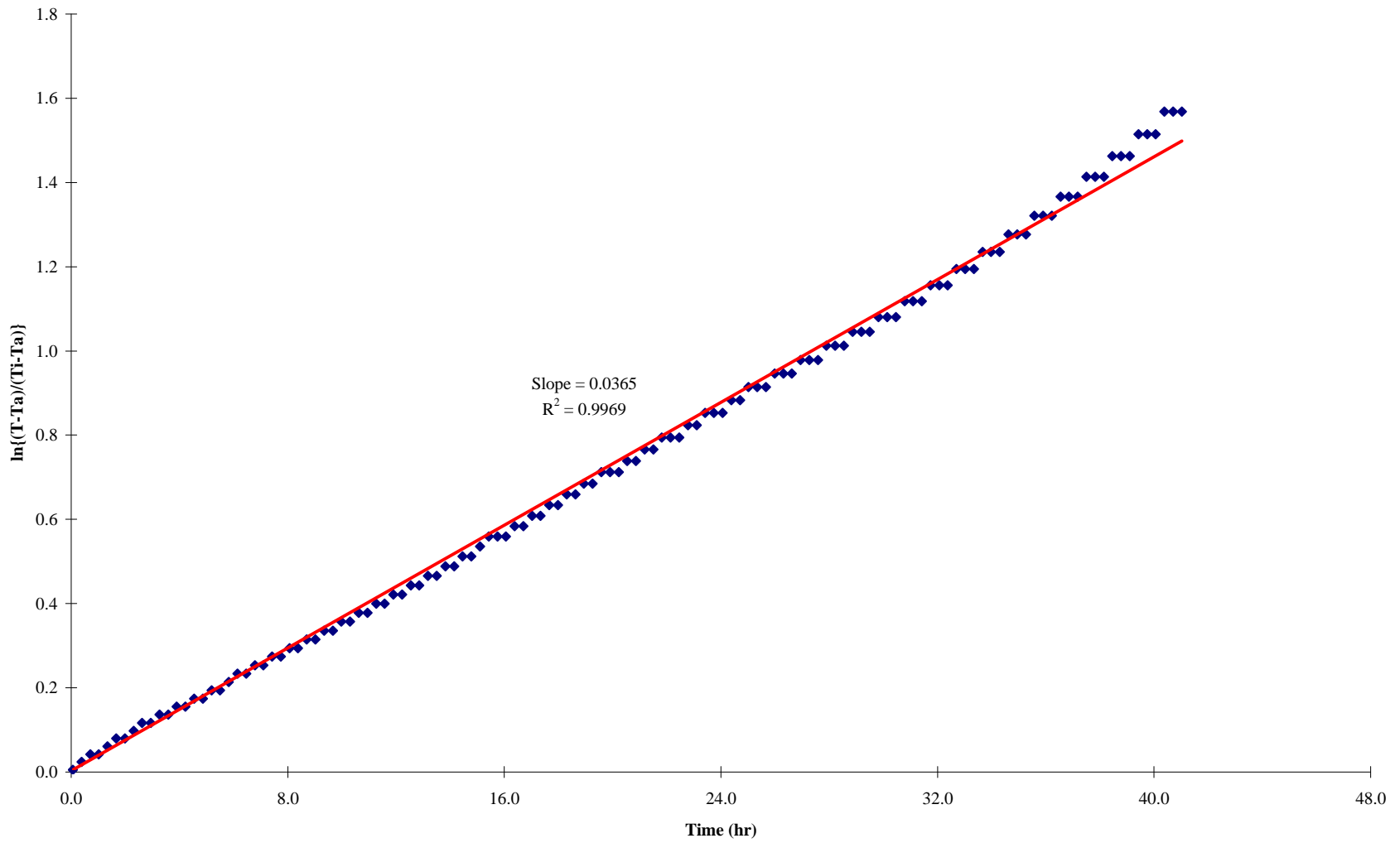

FIGURE C-18. Linearization of the Water Temperature Profile for R-01-8.5B Trial 3.

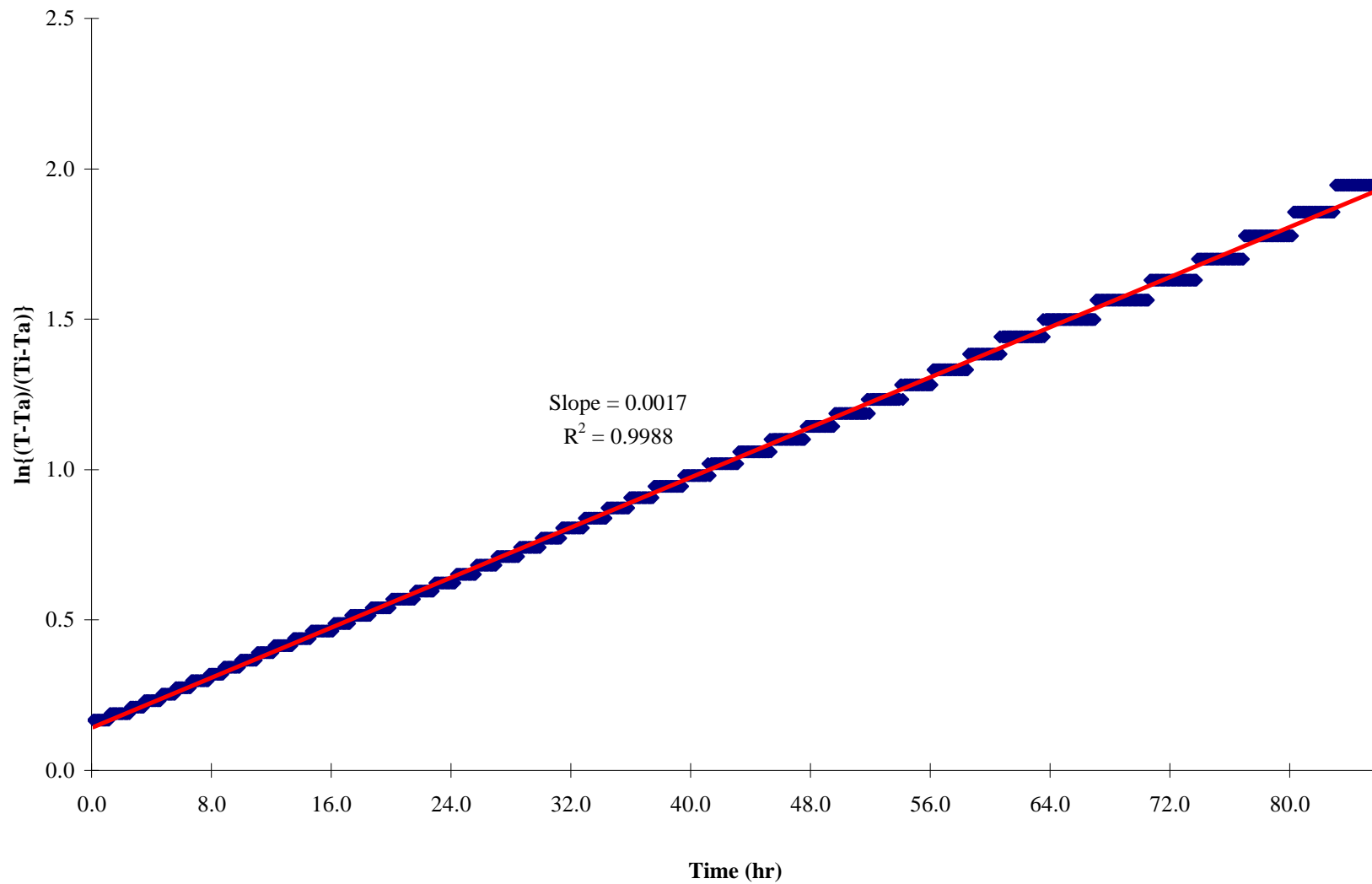

FIGURE C-19. Linearization of the Water Temperature Profile for R-04-12 Trial 1.

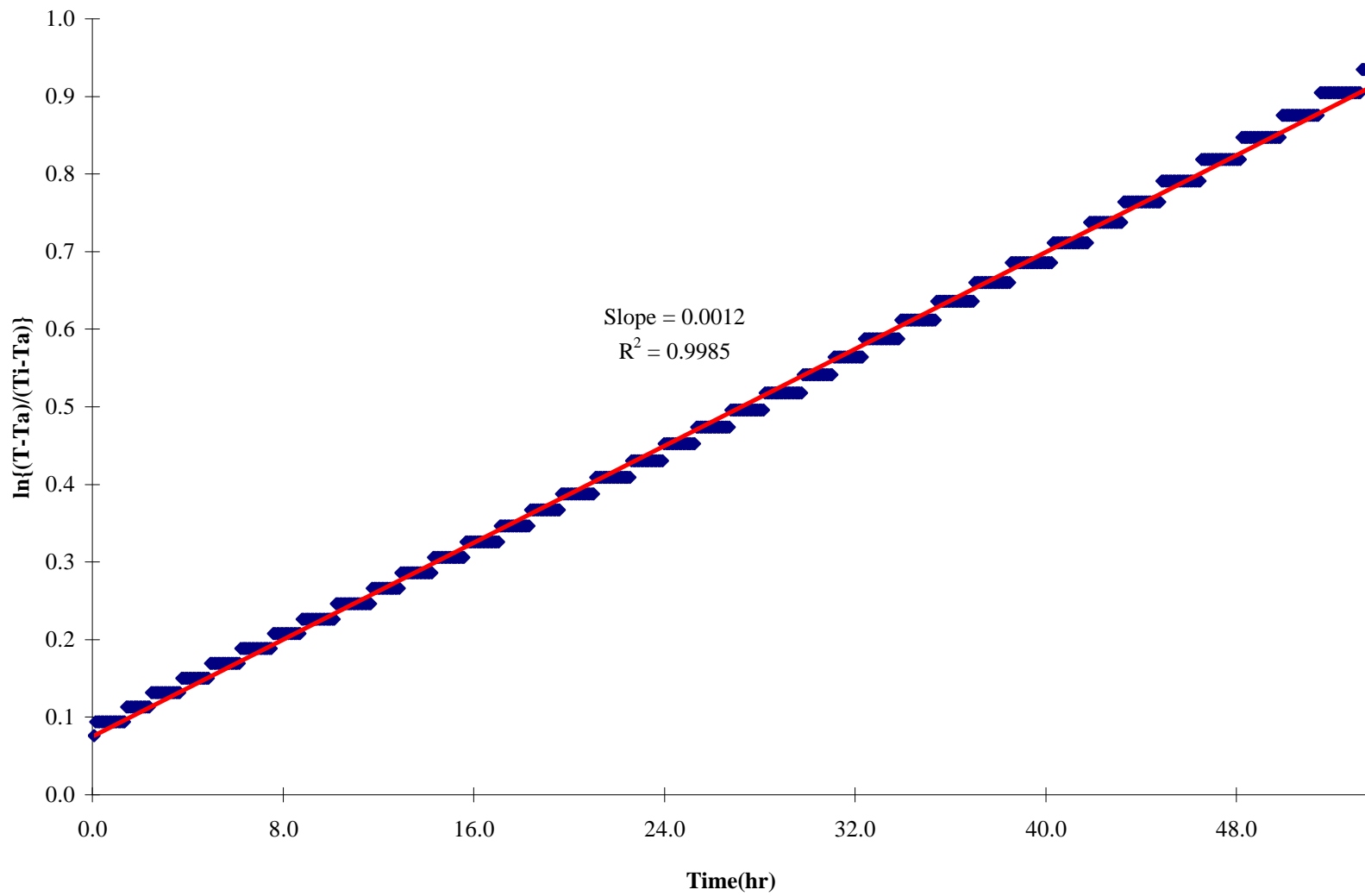

FIGURE C-20. Linearization of the Water Temperature Profile for R-07-12 Trial 1.

APPENDIX D: TEMPERATURE PROFILE DATA OF COMPOST TRIALS

Mix 1 R-01-3.5B Air Temperature Profile

Temperature Logging Started: 1230 on 5/23/96

Stopped: 1045 on 5/28/96

<u>Time</u> <u>(days)</u>	<u>Temperature</u> <u>(*C)</u>	<u>Time</u> <u>(days)</u>	<u>Temperature</u> <u>(*C)</u>	<u>Time</u> <u>(days)</u>	<u>Temperature</u> <u>(*C)</u>	<u>Time</u> <u>(days)</u>	<u>Temperature</u> <u>(*C)</u>
				1.680	24.5	2.520	22.0
				1.700	24.5	2.540	22.7
				1.720	24.5	2.560	23.4
				1.740	24.8	2.580	23.7
				1.760	24.8	2.600	24.1
				1.780	24.8	2.620	24.1
				1.800	23.4	2.640	24.5
				1.820	22.3	2.660	24.5
				1.840	22.0	2.680	24.8
		1.020	22.0	1.860	21.6	2.700	25.2
		1.040	21.6	1.880	21.3	2.720	25.2
		1.060	21.6	1.900	21.3	2.740	25.2
		1.080	21.3	1.920	22.7	2.760	25.2
		1.100	21.3	1.940	22.0	2.780	23.4
		1.120	21.3	1.960	22.0	2.800	22.7
		1.140	21.3	1.980	22.0	2.820	22.3
		1.160	21.3	2.000	21.6	2.840	22.0
		1.180	21.3	2.020	21.6	2.860	22.0
		1.200	21.3	2.040	21.6	2.880	21.6
		1.220	21.3	2.060	21.6	2.900	21.6
		1.240	21.3	2.080	21.3	2.920	21.6
		1.260	21.3	2.100	21.3	2.940	21.6
		1.280	21.3	2.120	21.3	2.960	21.3
		1.300	21.3	2.140	21.3	2.980	21.6
		1.320	20.9	2.160	21.3	3.000	21.6
		1.340	20.9	2.180	21.3	3.020	21.6
		1.360	20.9	2.200	21.3	3.040	21.3
		1.380	20.9	2.220	21.3	3.060	21.6
		1.400	20.9	2.240	21.3	3.080	21.6
		1.420	20.6	2.260	21.3	3.100	21.6
		1.440	20.6	2.280	21.3	3.120	21.6
		1.460	20.6	2.300	21.3	3.140	21.6
		1.480	20.6	2.320	21.3	3.160	21.6
		1.500	20.9	2.340	21.3	3.180	21.6
		1.520	21.6	2.360	21.3	3.200	21.6
		1.540	22.3	2.380	21.3	3.220	21.6
		1.560	22.7	2.400	20.9	3.240	21.6
		1.580	23.0	2.420	20.9	3.260	21.6
		1.600	23.4	2.440	20.9	3.280	21.6
		1.620	23.7	2.460	20.9	3.300	21.6
		1.640	23.7	2.480	20.9	3.320	21.6
		1.660	24.1	2.500	21.3	3.340	21.6

Time (days)	Temperature (*C)	Time (days)	Temperature (*C)	Time (days)	Temperature (*C)
3.360	21.6	4.280	22.0	5.200	21.6
3.380	21.3	4.300	22.0	5.220	21.6
3.400	21.3	4.320	21.6	5.240	21.6
3.420	21.3	4.340	21.6	5.260	21.6
3.440	21.3	4.360	21.6	5.280	21.3
3.460	21.3	4.380	21.6	5.300	21.3
3.480	20.9	4.400	21.6	5.320	21.3
3.500	21.6	4.420	21.6	5.340	21.3
3.520	22.3	4.440	21.3	5.360	21.3
3.540	23.0	4.460	21.3	5.380	21.3
3.560	23.4	4.480	21.3	5.400	21.3
3.580	24.1	4.500	22.0	5.420	21.3
3.600	24.5	4.520	23.0	5.440	21.3
3.620	24.5	4.540	23.7	5.460	21.3
3.640	24.8	4.560	24.5	5.480	20.9
3.660	24.8	4.580	24.8	5.500	22.0
3.680	25.2	4.600	25.2	5.520	23.0
3.700	25.5	4.620	25.2	5.540	23.7
3.720	25.5	4.640	25.5	5.560	24.5
3.740	25.5	4.660	25.9	5.580	24.8
3.760	25.9	4.680	25.9	5.600	25.2
3.780	25.9	4.700	26.2	5.620	25.5
3.800	23.7	4.720	26.2	5.640	25.5
3.820	23.0	4.740	26.6	5.660	25.5
3.840	22.7	4.760	24.1	5.680	25.9
3.860	22.3	4.780	23.4	5.700	25.9
3.880	22.0	4.800	22.7	5.720	25.9
3.900	22.0	4.820	22.3	5.740	25.9
3.920	22.0	4.840	22.0	5.760	26.2
3.940	22.0	4.860	22.0	5.780	26.2
3.960	21.6	4.880	21.6	5.800	24.1
3.980	21.6	4.900	21.6	5.820	23.0
4.000	21.6	4.920	21.6	5.840	22.7
4.020	21.6	4.940	21.6	5.860	22.3
4.040	22.0	4.960	21.6	5.880	22.0
4.060	22.0	4.980	21.6	5.900	22.0
4.080	22.0	5.000	21.6	5.920	22.0
4.100	22.0	5.020	21.6		
4.120	22.0	5.040	21.6		
4.140	22.3	5.060	21.6		
4.160	22.0	5.080	21.6		
4.180	22.3	5.100	21.6		
4.200	22.0	5.120	21.6		
4.220	22.3	5.140	21.6		
4.240	22.3	5.160	22.0		
4.260	22.0	5.180	21.6		

Mix 1 R-01-3.5B Temperature Profile

Temperature Logging Started: 1045 on 5/22/96

Stopped: 1045 on 5/28/96

<u>Time</u> <u>(days)</u>	<u>Temperature</u> <u>(*C)</u>	<u>Time</u> <u>(days)</u>	<u>Temperature</u> <u>(*C)</u>	<u>Time</u> <u>(days)</u>	<u>Temperature</u> <u>(*C)</u>	<u>Time</u> <u>(days)</u>	<u>Temperature</u> <u>(*C)</u>
.000	-37.7	.840	-37.7	1.680	-37.7	2.520	22.9
.020	-37.7	.860	-37.7	1.700	-37.7	2.540	22.9
.040	-37.7	.880	-37.7	1.720	-37.7	2.560	22.9
.060	-37.7	.900	-37.7	1.740	-37.7	2.580	22.9
.080	-37.7	.920	-37.7	1.760	-37.7	2.600	22.9
.100	-37.7	.940	-37.7	1.780	-37.7	2.620	23.3
.120	-37.7	.960	-37.7	1.800	-37.7	2.640	23.6
.140	-37.7	.980	-37.7	1.820	-37.7	2.660	24.4
.160	-37.7	1.000	-37.7	1.840	-37.7	2.680	24.7
.180	-37.7	1.020	-37.7	1.860	-37.7	2.700	25.1
.200	-37.7	1.040	-37.7	1.880	-37.7	2.720	25.4
.220	-37.7	1.060	-37.7	1.900	-37.7	2.740	25.8
.240	-37.7	1.080	-37.7	1.920	-37.7	2.760	25.8
.260	-37.7	1.100	-37.7	1.940	-37.7	2.780	25.4
.280	-37.7	1.120	-37.7	1.960	-37.7	2.800	-37.7
.300	-37.7	1.140	-37.7	1.980	-37.7	2.820	-37.7
.320	-37.7	1.160	-37.7	2.000	-37.7	2.840	-37.7
.340	-37.7	1.180	-37.7	2.020	-37.7	2.860	-37.7
.360	-37.7	1.200	-37.7	2.040	-37.7	2.880	-37.7
.380	-37.7	1.220	-37.7	2.060	-37.7	2.900	-37.7
.400	-37.7	1.240	-37.7	2.080	-37.7	2.920	-37.7
.420	-37.7	1.260	-37.7	2.100	24.0	2.940	-37.7
.440	-37.7	1.280	-37.7	2.120	23.6	2.960	-37.7
.460	-37.7	1.300	-37.7	2.140	23.6	2.980	-37.7
.480	-37.7	1.320	-37.7	2.160	23.6	3.000	-37.7
.500	-37.7	1.340	-37.7	2.180	23.6	3.020	-37.7
.520	-37.7	1.360	-37.7	2.200	23.3	3.040	-37.7
.540	-37.7	1.380	-37.7	2.220	23.3	3.060	-37.7
.560	-37.7	1.400	-37.7	2.240	23.3	3.080	-37.7
.580	-37.7	1.420	-37.7	2.260	23.3	3.100	-37.7
.600	-37.7	1.440	-37.7	2.280	23.3	3.120	-37.7
.620	-37.7	1.460	-37.7	2.300	23.3	3.140	-37.7
.640	-37.7	1.480	-37.7	2.320	23.3	3.160	-37.7
.660	-37.7	1.500	-37.7	2.340	23.3	3.180	-37.7
.680	-37.7	1.520	-37.7	2.360	23.3	3.200	-37.7
.700	-37.7	1.540	-37.7	2.380	23.3	3.220	-37.7
.720	-37.7	1.560	-37.7	2.400	22.9	3.240	-37.7
.740	-37.7	1.580	-37.7	2.420	22.9	3.260	-37.7
.760	-37.7	1.600	-37.7	2.440	22.9	3.280	-37.7
.780	-37.7	1.620	-37.7	2.460	22.9	3.300	-37.7
.800	-37.7	1.640	-37.7	2.480	22.9	3.320	-37.7
.820	-37.7	1.660	-37.7	2.500	22.9	3.340	-37.7

Time (days)	Temperature (*C)	Time (days)	Temperature (*C)	Time (days)	Temperature (*C)
3.360	-37.7	4.280	-37.7	5.200	22.6
3.380	-37.7	4.300	-37.7	5.220	22.6
3.400	-37.7	4.320	-37.7	5.240	22.6
3.420	-37.7	4.340	-37.7	5.260	22.6
3.440	-37.7	4.360	-37.7	5.280	22.6
3.460	-37.7	4.380	-37.7	5.300	22.2
3.480	-36.4	4.400	-37.7	5.320	22.2
3.500	-36.4	4.420	-37.7	5.340	22.2
3.520	-36.4	4.440	-37.7	5.360	22.2
3.540	-36.4	4.460	-37.7	5.380	22.2
3.560	-33.9	4.480	-37.7	5.400	22.2
3.580	-37.7	4.500	-37.7	5.420	22.2
3.600	-37.7	4.520	-37.7	5.440	22.2
3.620	-37.7	4.540	-37.7	5.460	22.2
3.640	-37.7	4.560	-37.7	5.480	22.2
3.660	-37.7	4.580	-37.7	5.500	21.9
3.680	-37.7	4.600	-37.7	5.520	21.9
3.700	-37.7	4.620	-37.7	5.540	21.9
3.720	-37.7	4.640	-37.7	5.560	21.9
3.740	-37.7	4.660	-37.7	5.580	21.9
3.760	-37.7	4.680	-37.7	5.600	22.2
3.780	-37.7	4.700	-37.7	5.620	22.6
3.800	-37.7	4.720	-37.7	5.640	22.9
3.820	-37.7	4.740	-37.7	5.660	23.3
3.840	-37.7	4.760	25.4	5.680	23.6
3.860	-37.7	4.780	25.8	5.700	24.0
3.880	-37.7	4.800	25.8	5.720	24.4
3.900	-37.7	4.820	26.1	5.740	24.7
3.920	-37.7	4.840	25.8	5.760	25.1
3.940	-37.7	4.860	25.4	5.780	25.1
3.960	-37.7	4.880	25.1	5.800	25.4
3.980	-37.7	4.900	24.7	5.820	25.4
4.000	-37.7	4.920	24.4	5.840	25.8
4.020	-37.7	4.940	24.0	5.860	25.8
4.040	-37.7	4.960	23.6	5.880	25.4
4.060	-37.7	4.980	23.6	5.900	25.4
4.080	-37.7	5.000	23.3	5.920	24.7
4.100	-37.7	5.020	22.9	5.940	24.4
4.120	-37.7	5.040	22.9	5.960	24.0
4.140	-37.7	5.060	22.9	5.980	24.0
4.160	-37.7	5.080	22.6		
4.180	-37.7	5.100	22.6		
4.200	-37.7	5.120	22.6		
4.220	-37.7	5.140	22.6		
4.240	-37.7	5.160	22.6		
4.260	-37.7	5.180	22.6		

Mix 1 R-01-6.5B Temperature Profile

Temperature Logging Started: 1045 on 5/22/96

Stopped: 1045 on 5/28/96

<u>Time</u> <u>(days)</u>	<u>Temperature</u> <u>(*C)</u>	<u>Time</u> <u>(days)</u>	<u>Temperature</u> <u>(*C)</u>	<u>Time</u> <u>(days)</u>	<u>Temperature</u> <u>(*C)</u>	<u>Time</u> <u>(days)</u>	<u>Temperature</u> <u>(*C)</u>
.000	24.3	.840	28.6	1.680	24.3	2.520	23.2
.020	27.5	.860	29.0	1.700	24.6	2.540	23.2
.040	27.5	.880	28.6	1.720	25.0	2.560	23.2
.060	27.5	.900	28.2	1.740	25.4	2.580	23.2
.080	27.5	.920	27.9	1.760	25.7	2.600	23.2
.100	27.9	.940	27.5	1.780	25.7	2.620	23.6
.120	28.2	.960	27.2	1.800	26.1	2.640	23.9
.140	28.6	.980	26.8	1.820	26.4	2.660	24.3
.160	28.6	1.000	26.8	1.840	26.4	2.680	24.6
.180	28.6	1.020	26.1	1.860	26.4	2.700	25.0
.200	28.6	1.040	25.7	1.880	26.4	2.720	25.4
.220	28.6	1.060	25.4	1.900	25.7	2.740	25.7
.240	28.2	1.080	25.0	1.920	25.4	2.760	25.7
.260	27.9	1.100	25.0	1.940	25.0	2.780	26.1
.280	27.5	1.120	24.6	1.960	24.6	2.800	26.4
.300	27.2	1.140	24.6	1.980	24.6	2.820	26.4
.320	27.2	1.160	24.3	2.000	24.6	2.840	26.8
.340	26.8	1.180	24.3	2.020	24.6	2.860	26.4
.360	26.4	1.200	24.3	2.040	24.6	2.880	26.1
.380	26.1	1.220	23.9	2.060	24.3	2.900	25.7
.400	26.1	1.240	23.9	2.080	24.3	2.920	25.4
.420	26.1	1.260	23.9	2.100	24.3	2.940	25.0
.440	26.1	1.280	23.9	2.120	23.9	2.960	25.0
.460	26.1	1.300	23.6	2.140	23.9	2.980	24.6
.480	26.1	1.320	23.6	2.160	23.9	3.000	24.3
.500	26.1	1.340	23.6	2.180	23.9	3.020	24.3
.520	25.7	1.360	23.6	2.200	23.9	3.040	24.3
.540	25.7	1.380	23.6	2.220	23.9	3.060	23.9
.560	25.7	1.400	23.6	2.240	23.6	3.080	23.9
.580	25.7	1.420	23.6	2.260	23.6	3.100	23.9
.600	25.7	1.440	23.6	2.280	23.6	3.120	23.9
.620	25.7	1.460	23.2	2.300	23.6	3.140	23.9
.640	26.1	1.480	23.2	2.320	23.6	3.160	23.6
.660	26.4	1.500	23.2	2.340	23.6	3.180	23.6
.680	26.8	1.520	23.2	2.360	23.6	3.200	23.6
.700	26.8	1.540	22.9	2.380	23.6	3.220	23.6
.720	27.2	1.560	22.9	2.400	23.6	3.240	23.6
.740	27.5	1.580	22.9	2.420	23.6	3.260	23.6
.760	27.9	1.600	23.2	2.440	23.2	3.280	23.6
.780	27.9	1.620	23.6	2.460	23.2	3.300	23.6
.800	28.2	1.640	23.6	2.480	23.2	3.320	23.6
.820	28.6	1.660	23.9	2.500	23.2	3.340	23.6

Time (days)	Temperature (*C)	Time (days)	Temperature (*C)	Time (days)	Temperature (*C)
3.360	23.6	4.280	23.6	5.200	23.2
3.380	23.6	4.300	23.6	5.220	23.2
3.400	23.6	4.320	23.6	5.240	23.2
3.420	23.6	4.340	23.6	5.260	23.2
3.440	23.6	4.360	23.6	5.280	23.2
3.460	23.6	4.380	23.6	5.300	22.9
3.480	23.6	4.400	23.6	5.320	22.9
3.500	23.2	4.420	23.6	5.340	22.9
3.520	23.2	4.440	23.6	5.360	22.9
3.540	23.2	4.460	23.2	5.380	22.9
3.560	23.2	4.480	23.2	5.400	22.9
3.580	23.2	4.500	23.2	5.420	22.9
3.600	23.6	4.520	23.2	5.440	22.9
3.620	23.6	4.540	23.2	5.460	22.5
3.640	23.9	4.560	22.9	5.480	22.5
3.660	24.3	4.580	23.2	5.500	22.5
3.680	24.6	4.600	23.2	5.520	22.5
3.700	25.0	4.620	23.6	5.540	22.5
3.720	25.4	4.640	23.9	5.560	22.5
3.740	25.7	4.660	24.3	5.580	22.5
3.760	25.7	4.680	24.6	5.600	22.9
3.780	26.1	4.700	25.0	5.620	23.2
3.800	26.4	4.720	25.4	5.640	23.6
3.820	26.4	4.740	25.7	5.660	23.9
3.840	26.4	4.760	25.7	5.680	24.3
3.860	26.8	4.780	26.1	5.700	24.6
3.880	26.4	4.800	26.4	5.720	25.0
3.900	26.1	4.820	26.4	5.740	25.4
3.920	25.7	4.840	26.1	5.760	25.7
3.940	25.4	4.860	25.7	5.780	25.7
3.960	25.0	4.880	25.4	5.800	26.1
3.980	24.6	4.900	25.0	5.820	26.1
4.000	24.6	4.920	24.6	5.840	26.4
4.020	24.3	4.940	24.3	5.860	26.4
4.040	24.3	4.960	24.3	5.880	26.1
4.060	23.9	4.980	23.9	5.900	25.7
4.080	23.9	5.000	23.9	5.920	25.4
4.100	23.9	5.020	23.6	5.940	25.0
4.120	23.9	5.040	23.6	5.960	24.6
4.140	23.6	5.060	23.2	5.980	24.3
4.160	23.6	5.080	23.2		
4.180	23.6	5.100	23.2		
4.200	23.6	5.120	23.2		
4.220	23.9	5.140	23.2		
4.240	23.6	5.160	23.2		
4.260	23.9	5.180	23.2		

Mix 1 R-01-8.5B Temperature Profile

Temperature Logging Started: 1045 on 5/22/96

Stopped: 1045 on 5/28/96

<u>Time</u> <u>(days)</u>	<u>Temperature</u> <u>(*C)</u>	<u>Time</u> <u>(days)</u>	<u>Temperature</u> <u>(*C)</u>	<u>Time</u> <u>(days)</u>	<u>Temperature</u> <u>(*C)</u>	<u>Time</u> <u>(days)</u>	<u>Temperature</u> <u>(*C)</u>
.000	24.1	.840	28.8	1.680	24.5	2.520	23.7
.020	27.7	.860	28.8	1.700	24.8	2.540	23.7
.040	27.7	.880	28.8	1.720	25.2	2.560	23.4
.060	28.0	.900	28.4	1.740	25.2	2.580	23.7
.080	28.0	.920	28.4	1.760	25.5	2.600	23.7
.100	28.4	.940	28.0	1.780	25.5	2.620	24.1
.120	29.1	.960	28.0	1.800	25.9	2.640	24.1
.140	29.5	.980	27.7	1.820	25.9	2.660	24.5
.160	29.9	1.000	27.7	1.840	26.2	2.680	24.8
.180	30.2	1.020	27.0	1.860	26.2	2.700	25.2
.200	30.2	1.040	26.6	1.880	26.2	2.720	25.2
.220	30.2	1.060	26.2	1.900	25.9	2.740	25.5
.240	29.9	1.080	25.9	1.920	25.5	2.760	25.5
.260	29.5	1.100	25.5	1.940	25.2	2.780	25.9
.280	29.5	1.120	25.5	1.960	25.2	2.800	25.9
.300	28.8	1.140	25.2	1.980	25.2	2.820	26.2
.320	28.4	1.160	25.2	2.000	25.2	2.840	26.2
.340	28.0	1.180	25.2	2.020	24.8	2.860	26.2
.360	27.7	1.200	25.2	2.040	24.8	2.880	25.9
.380	27.3	1.220	25.2	2.060	24.8	2.900	25.5
.400	27.3	1.240	24.8	2.080	24.8	2.920	25.5
.420	27.3	1.260	24.8	2.100	24.8	2.940	25.2
.440	27.3	1.280	24.8	2.120	24.8	2.960	25.2
.460	27.3	1.300	24.5	2.140	24.5	2.980	24.8
.480	27.0	1.320	24.5	2.160	24.5	3.000	24.8
.500	27.0	1.340	24.5	2.180	24.5	3.020	24.5
.520	26.6	1.360	24.5	2.200	24.5	3.040	24.5
.540	26.6	1.380	24.5	2.220	24.5	3.060	24.5
.560	26.6	1.400	24.5	2.240	24.5	3.080	24.5
.580	26.6	1.420	24.1	2.260	24.5	3.100	24.5
.600	26.6	1.440	24.1	2.280	24.5	3.120	24.1
.620	26.6	1.460	24.1	2.300	24.1	3.140	24.1
.640	27.0	1.480	24.1	2.320	24.1	3.160	24.1
.660	27.0	1.500	23.7	2.340	24.1	3.180	24.1
.680	27.3	1.520	23.7	2.360	24.1	3.200	24.1
.700	27.3	1.540	23.7	2.380	24.1	3.220	24.1
.720	27.7	1.560	23.7	2.400	24.1	3.240	24.1
.740	27.7	1.580	23.7	2.420	24.1	3.260	24.1
.760	28.0	1.600	23.7	2.440	23.7	3.280	24.1
.780	28.0	1.620	23.7	2.460	23.7	3.300	24.1
.800	28.4	1.640	24.1	2.480	23.7	3.320	24.1
.820	28.4	1.660	24.5	2.500	23.7	3.340	24.1

Time (days)	Temperature (*C)	Time (days)	Temperature (*C)	Time (days)	Temperature (*C)
3.360	24.1	4.280	24.1	5.200	23.7
3.380	24.1	4.300	24.1	5.220	23.7
3.400	24.1	4.320	24.1	5.240	23.7
3.420	24.1	4.340	24.1	5.260	23.7
3.440	23.7	4.360	24.1	5.280	23.7
3.460	23.7	4.380	24.1	5.300	23.7
3.480	23.7	4.400	24.1	5.320	23.7
3.500	23.7	4.420	24.1	5.340	23.4
3.520	23.7	4.440	23.7	5.360	23.4
3.540	23.4	4.460	23.7	5.380	23.4
3.560	23.4	4.480	23.7	5.400	23.4
3.580	23.4	4.500	23.7	5.420	23.4
3.600	23.7	4.520	23.4	5.440	23.0
3.620	24.1	4.540	23.4	5.460	23.0
3.640	24.1	4.560	23.4	5.480	23.0
3.660	24.5	4.580	23.4	5.500	23.0
3.680	24.8	4.600	23.7	5.520	23.0
3.700	25.2	4.620	24.1	5.540	23.0
3.720	25.2	4.640	24.1	5.560	22.7
3.740	25.5	4.660	24.5	5.580	23.0
3.760	25.5	4.680	24.8	5.600	23.4
3.780	25.9	4.700	25.2	5.620	23.4
3.800	25.9	4.720	25.2	5.640	23.7
3.820	26.2	4.740	25.5	5.660	24.1
3.840	26.2	4.760	25.5	5.680	24.5
3.860	26.2	4.780	25.9	5.700	24.8
3.880	26.2	4.800	26.2	5.720	25.2
3.900	25.9	4.820	26.2	5.740	25.2
3.920	25.5	4.840	25.9	5.760	25.5
3.940	25.2	4.860	25.5	5.780	25.9
3.960	25.2	4.880	25.5	5.800	25.9
3.980	24.8	4.900	25.2	5.820	25.9
4.000	24.8	4.920	24.8	5.840	26.2
4.020	24.5	4.940	24.8	5.860	26.2
4.040	24.5	4.960	24.5	5.880	25.9
4.060	24.5	4.980	24.5	5.900	25.5
4.080	24.5	5.000	24.1	5.920	25.2
4.100	24.5	5.020	24.1	5.940	25.2
4.120	24.1	5.040	24.1	5.960	24.8
4.140	24.1	5.060	23.7	5.980	24.8
4.160	24.1	5.080	23.7		
4.180	24.1	5.100	23.7		
4.200	24.1	5.120	23.7		
4.220	24.1	5.140	23.7		
4.240	24.5	5.160	23.7		
4.260	24.1	5.180	23.7		

Mix 1 R-04-12 Temperature Profile

Temperature Logging Sta: Started: 1045 on 5/22/96

Stopped: 1045 on 5/28/96

<u>Time</u> <u>(days)</u>	<u>Temperature</u> <u>(*C)</u>	<u>Time</u> <u>(days)</u>	<u>Temperature</u> <u>(*C)</u>	<u>Time</u> <u>(days)</u>	<u>Temperature</u> <u>(*C)</u>	<u>Time</u> <u>(days)</u>	<u>Temperature</u> <u>(*C)</u>
.000	24.3	.840	32.7	1.680	27.9	2.520	26.8
.020	30.0	.860	33.0	1.700	27.9	2.540	26.8
.040	30.8	.880	33.0	1.720	28.2	2.560	26.8
.060	31.9	.900	33.0	1.740	28.2	2.580	26.8
.080	33.4	.920	33.0	1.760	28.6	2.600	26.8
.100	34.6	.940	32.7	1.780	28.6	2.620	27.1
.120	36.1	.960	32.7	1.800	28.9	2.640	27.1
.140	37.3	.980	32.3	1.820	28.9	2.660	27.5
.160	38.1	1.000	31.9	1.840	29.3	2.680	27.5
.180	38.6	1.020	31.5	1.860	29.3	2.700	27.9
.200	39.0	1.040	30.8	1.880	29.3	2.720	27.9
.220	38.6	1.060	30.4	1.900	29.3	2.740	28.2
.240	38.6	1.080	29.7	1.920	28.9	2.760	28.6
.260	38.1	1.100	29.7	1.940	28.9	2.780	28.6
.280	37.3	1.120	29.3	1.960	28.6	2.800	28.6
.300	36.9	1.140	28.9	1.980	28.2	2.820	28.9
.320	36.5	1.160	28.9	2.000	28.2	2.840	28.9
.340	36.1	1.180	28.6	2.020	28.2	2.860	28.9
.360	35.4	1.200	28.6	2.040	28.2	2.880	28.9
.380	35.0	1.220	28.2	2.060	27.9	2.900	28.6
.400	34.6	1.240	28.2	2.080	27.9	2.920	28.6
.420	34.2	1.260	28.2	2.100	27.9	2.940	28.2
.440	34.2	1.280	27.9	2.120	27.9	2.960	28.2
.460	33.8	1.300	27.9	2.140	27.5	2.980	27.9
.480	33.4	1.320	27.9	2.160	27.5	3.000	27.5
.500	33.0	1.340	27.9	2.180	27.5	3.020	27.5
.520	32.7	1.360	27.9	2.200	27.5	3.040	27.5
.540	32.7	1.380	27.9	2.220	27.5	3.060	27.1
.560	32.3	1.400	27.5	2.240	27.5	3.080	27.1
.580	31.9	1.420	27.5	2.260	27.1	3.100	27.1
.600	31.9	1.440	27.5	2.280	27.1	3.120	27.1
.620	31.9	1.460	27.5	2.300	27.1	3.140	26.8
.640	31.9	1.480	27.5	2.320	27.1	3.160	26.8
.660	31.9	1.500	27.5	2.340	27.1	3.180	26.8
.680	31.9	1.520	27.1	2.360	27.1	3.200	26.8
.700	31.9	1.540	27.1	2.380	27.1	3.220	26.8
.720	31.9	1.560	27.1	2.400	27.1	3.240	26.8
.740	32.3	1.580	27.1	2.420	27.1	3.260	26.8
.760	32.3	1.600	27.1	2.440	27.1	3.280	26.8
.780	32.3	1.620	27.1	2.460	27.1	3.300	26.8
.800	32.7	1.640	27.1	2.480	27.1	3.320	26.8
.820	32.7	1.660	27.5	2.500	26.8	3.340	26.8

Time (days)	Temperature (*C)	Time (days)	Temperature (*C)	Time (days)	Temperature (*C)
3.360	26.8	4.280	26.4	5.200	25.3
3.380	26.8	4.300	26.4	5.220	25.3
3.400	26.8	4.320	26.4	5.240	25.3
3.420	26.8	4.340	26.1	5.260	25.3
3.440	26.4	4.360	26.1	5.280	25.3
3.460	26.4	4.380	26.1	5.300	25.3
3.480	26.4	4.400	26.1	5.320	25.3
3.500	26.4	4.420	26.1	5.340	25.3
3.520	26.4	4.440	26.1	5.360	25.3
3.540	26.4	4.460	26.1	5.380	25.3
3.560	26.4	4.480	26.1	5.400	25.0
3.580	26.1	4.500	25.7	5.420	25.0
3.600	26.4	4.520	25.7	5.440	25.0
3.620	26.4	4.540	25.7	5.460	25.0
3.640	26.4	4.560	25.7	5.480	25.0
3.660	26.8	4.580	25.7	5.500	25.0
3.680	27.1	4.600	25.7	5.520	25.0
3.700	27.1	4.620	25.7	5.540	25.0
3.720	27.5	4.640	26.1	5.560	24.6
3.740	27.5	4.660	26.4	5.580	24.6
3.760	27.9	4.680	26.4	5.600	25.0
3.780	27.9	4.700	26.8	5.620	25.0
3.800	28.2	4.720	27.1	5.640	25.3
3.820	28.2	4.740	27.1	5.660	25.7
3.840	28.2	4.760	27.5	5.680	25.7
3.860	28.6	4.780	27.5	5.700	26.1
3.880	28.6	4.800	27.9	5.720	26.4
3.900	28.2	4.820	27.9	5.740	26.4
3.920	28.2	4.840	27.9	5.760	26.8
3.940	27.9	4.860	27.9	5.780	26.8
3.960	27.5	4.880	27.5	5.800	27.1
3.980	27.5	4.900	27.1	5.820	27.1
4.000	27.1	4.920	27.1	5.840	27.1
4.020	26.8	4.940	26.8	5.860	27.5
4.040	26.8	4.960	26.4	5.880	27.5
4.060	26.8	4.980	26.4	5.900	27.1
4.080	26.4	5.000	26.1	5.920	27.1
4.100	26.4	5.020	26.1	5.940	26.8
4.120	26.4	5.040	25.7	5.960	26.4
4.140	26.4	5.060	25.7	5.980	26.4
4.160	26.4	5.080	25.7		
4.180	26.4	5.100	25.7		
4.200	26.4	5.120	25.7		
4.220	26.4	5.140	25.3		
4.240	26.4	5.160	25.3		
4.260	26.4	5.180	25.3		

Mix 1 R-07-12 Temperature Profile

Temperature Logging Started: 1045 on 5/22/96

Stopped: 1045 on 5/28/96

<u>Time</u> <u>(days)</u>	<u>Temperature</u> <u>(*C)</u>	<u>Time</u> <u>(days)</u>	<u>Temperature</u> <u>(*C)</u>	<u>Time</u> <u>(days)</u>	<u>Temperature</u> <u>(*C)</u>	<u>Time</u> <u>(days)</u>	<u>Temperature</u> <u>(*C)</u>
.000	24.1	.840	35.2	1.680	29.9	2.520	29.1
.020	29.5	.860	35.6	1.700	29.9	2.540	29.1
.040	31.0	.880	35.6	1.720	30.2	2.560	29.1
.060	32.5	.900	35.6	1.740	30.2	2.580	29.1
.080	34.0	.920	35.6	1.760	30.6	2.600	29.1
.100	36.0	.940	35.6	1.780	30.6	2.620	29.1
.120	38.4	.960	35.6	1.800	31.0	2.640	29.1
.140	40.4	.980	35.2	1.820	31.0	2.660	29.1
.160	41.7	1.000	35.2	1.840	31.4	2.680	29.5
.180	42.6	1.020	34.8	1.860	31.4	2.700	29.5
.200	43.5	1.040	34.0	1.880	31.4	2.720	29.5
.220	43.5	1.060	33.6	1.900	31.4	2.740	29.9
.240	43.5	1.080	33.2	1.920	31.4	2.760	29.9
.260	43.0	1.100	32.9	1.940	31.4	2.780	30.2
.280	43.0	1.120	32.5	1.960	31.4	2.800	30.2
.300	42.6	1.140	32.1	1.980	31.4	2.820	30.6
.320	41.7	1.160	31.7	2.000	31.0	2.840	30.6
.340	41.3	1.180	31.4	2.020	31.0	2.860	30.6
.360	40.9	1.200	31.4	2.040	31.0	2.880	30.6
.380	40.0	1.220	31.0	2.060	30.6	2.900	30.6
.400	39.6	1.240	31.0	2.080	30.6	2.920	30.6
.420	39.2	1.260	30.6	2.100	30.6	2.940	30.6
.440	38.4	1.280	30.6	2.120	30.6	2.960	30.2
.460	38.0	1.300	30.6	2.140	30.6	2.980	30.2
.480	37.5	1.320	30.2	2.160	30.2	3.000	29.9
.500	37.1	1.340	30.2	2.180	30.2	3.020	29.9
.520	36.7	1.360	30.2	2.200	30.2	3.040	29.5
.540	36.4	1.380	30.2	2.220	30.2	3.060	29.5
.560	36.0	1.400	30.2	2.240	30.2	3.080	29.1
.580	35.6	1.420	29.9	2.260	29.9	3.100	29.1
.600	35.6	1.440	29.9	2.280	29.9	3.120	29.1
.620	35.2	1.460	29.9	2.300	29.9	3.140	28.8
.640	34.8	1.480	29.9	2.320	29.9	3.160	28.8
.660	34.8	1.500	29.9	2.340	29.9	3.180	28.8
.680	34.8	1.520	29.9	2.360	29.9	3.200	28.8
.700	34.8	1.540	29.5	2.380	29.5	3.220	28.4
.720	34.8	1.560	29.5	2.400	29.5	3.240	28.4
.740	34.8	1.580	29.5	2.420	29.5	3.260	28.4
.760	34.8	1.600	29.5	2.440	29.5	3.280	28.4
.780	34.8	1.620	29.5	2.460	29.5	3.300	28.4
.800	35.2	1.640	29.5	2.480	29.5	3.320	28.4
.820	35.2	1.660	29.5	2.500	29.5	3.340	28.0

Time (days)	Temperature (*C)	Time (days)	Temperature (*C)	Time (days)	Temperature (*C)
3.360	28.0	4.280	27.3	5.200	26.2
3.380	28.0	4.300	27.3	5.220	26.2
3.400	28.0	4.320	27.3	5.240	25.9
3.420	28.0	4.340	27.3	5.260	25.9
3.440	28.0	4.360	27.3	5.280	25.9
3.460	28.0	4.380	27.3	5.300	25.9
3.480	28.0	4.400	27.3	5.320	25.9
3.500	27.7	4.420	27.3	5.340	25.9
3.520	27.7	4.440	27.0	5.360	25.9
3.540	27.7	4.460	27.0	5.380	25.9
3.560	27.7	4.480	27.0	5.400	25.5
3.580	27.7	4.500	27.0	5.420	25.5
3.600	27.7	4.520	27.0	5.440	25.5
3.620	27.7	4.540	27.0	5.460	25.5
3.640	27.7	4.560	26.6	5.480	25.5
3.660	27.7	4.580	26.6	5.500	25.5
3.680	28.0	4.600	26.6	5.520	25.5
3.700	28.0	4.620	26.6	5.540	25.5
3.720	28.4	4.640	26.6	5.560	25.5
3.740	28.4	4.660	27.0	5.580	25.5
3.760	28.8	4.680	27.0	5.600	25.2
3.780	28.8	4.700	27.3	5.620	25.5
3.800	29.1	4.720	27.3	5.640	25.5
3.820	29.1	4.740	27.3	5.660	25.5
3.840	29.1	4.760	27.7	5.680	25.9
3.860	29.5	4.780	27.7	5.700	25.9
3.880	29.5	4.800	28.0	5.720	26.2
3.900	29.5	4.820	28.0	5.740	26.2
3.920	29.5	4.840	28.4	5.760	26.6
3.940	29.1	4.860	28.4	5.780	26.6
3.960	29.1	4.880	28.0	5.800	27.0
3.980	28.8	4.900	28.0	5.820	27.0
4.000	28.8	4.920	28.0	5.840	27.3
4.020	28.4	4.940	27.7	5.860	27.3
4.040	28.4	4.960	27.7	5.880	27.3
4.060	28.0	4.980	27.3	5.900	27.3
4.080	28.0	5.000	27.3	5.920	27.3
4.100	28.0	5.020	27.0	5.940	27.3
4.120	27.7	5.040	27.0	5.960	27.0
4.140	27.7	5.060	26.6	5.980	27.0
4.160	27.7	5.080	26.6		
4.180	27.7	5.100	26.6		
4.200	27.3	5.120	26.2		
4.220	27.3	5.140	26.2		
4.240	27.3	5.160	26.2		
4.260	27.3	5.180	26.2		

Mix 1 R-10-12 Temperature Profile

Temperature Logging Started: 1045 on 5/22/96

Stopped: 1045 on 5/28/96

<u>Time</u> <u>(days)</u>	<u>Temperature</u> <u>(*C)</u>	<u>Time</u> <u>(days)</u>	<u>Temperature</u> <u>(*C)</u>	<u>Time</u> <u>(days)</u>	<u>Temperature</u> <u>(*C)</u>	<u>Time</u> <u>(days)</u>	<u>Temperature</u> <u>(*C)</u>
.000	24.1	.840	51.1	1.680	48.1	2.520	44.4
.020	29.9	.860	51.1	1.700	48.1	2.540	44.4
.040	31.4	.880	51.6	1.720	47.6	2.560	44.4
.060	33.6	.900	51.6	1.740	47.6	2.580	44.4
.080	36.0	.920	52.1	1.760	47.6	2.600	43.9
.100	39.2	.940	52.1	1.780	47.1	2.620	43.9
.120	42.1	.960	52.1	1.800	47.1	2.640	43.5
.140	44.8	.980	52.1	1.820	47.1	2.660	43.5
.160	47.1	1.000	52.7	1.840	46.7	2.680	43.0
.180	48.6	1.020	51.6	1.860	46.7	2.700	43.0
.200	49.6	1.040	50.6	1.880	46.7	2.720	42.6
.220	50.6	1.060	50.1	1.900	46.7	2.740	42.1
.240	50.6	1.080	49.6	1.920	46.7	2.760	42.1
.260	51.1	1.100	51.1	1.940	46.7	2.780	42.1
.280	51.1	1.120	52.1	1.960	47.1	2.800	41.7
.300	51.1	1.140	52.7	1.980	47.1	2.820	41.7
.320	51.1	1.160	52.1	2.000	46.7	2.840	41.7
.340	51.1	1.180	51.6	2.020	46.7	2.860	41.7
.360	51.1	1.200	50.6	2.040	46.7	2.880	41.7
.380	51.1	1.220	50.1	2.060	46.2	2.900	42.1
.400	51.1	1.240	49.6	2.080	46.2	2.920	42.1
.420	51.1	1.260	49.6	2.100	46.2	2.940	42.6
.440	51.1	1.280	49.1	2.120	46.2	2.960	42.6
.460	51.1	1.300	48.6	2.140	46.2	2.980	42.6
.480	51.1	1.320	48.1	2.160	46.2	3.000	42.6
.500	51.1	1.340	47.6	2.180	45.7	3.020	42.6
.520	51.1	1.360	47.6	2.200	45.7	3.040	42.6
.540	50.6	1.380	48.1	2.220	45.7	3.060	42.6
.560	50.6	1.400	48.6	2.240	45.7	3.080	42.6
.580	50.6	1.420	49.1	2.260	45.7	3.100	42.1
.600	50.6	1.440	49.6	2.280	45.3	3.120	42.1
.620	50.6	1.460	49.6	2.300	45.3	3.140	42.1
.640	50.6	1.480	49.6	2.320	45.3	3.160	42.1
.660	50.6	1.500	49.6	2.340	45.3	3.180	42.1
.680	50.1	1.520	50.1	2.360	45.3	3.200	42.1
.700	50.1	1.540	50.1	2.380	45.3	3.220	42.1
.720	50.1	1.560	50.1	2.400	44.8	3.240	42.1
.740	50.1	1.580	49.6	2.420	44.8	3.260	42.1
.760	50.6	1.600	49.6	2.440	44.8	3.280	42.1
.780	50.6	1.620	49.1	2.460	44.8	3.300	42.1
.800	50.6	1.640	48.6	2.480	44.8	3.320	41.7
.820	51.1	1.660	48.6	2.500	44.4	3.340	41.7

Time (days)	Temperature (*C)	Time (days)	Temperature (*C)	Time (days)	Temperature (*C)
3.360	41.7	4.280	40.9	5.200	40.4
3.380	41.7	4.300	40.9	5.220	40.4
3.400	41.7	4.320	40.4	5.240	40.0
3.420	41.7	4.340	40.4	5.260	40.0
3.440	41.7	4.360	40.4	5.280	40.0
3.460	41.7	4.380	40.4	5.300	40.0
3.480	41.7	4.400	40.4	5.320	40.0
3.500	41.7	4.420	40.4	5.340	40.0
3.520	41.7	4.440	40.4	5.360	40.0
3.540	41.7	4.460	40.4	5.380	40.0
3.560	41.7	4.480	40.4	5.400	40.0
3.580	41.3	4.500	40.4	5.420	40.0
3.600	41.3	4.520	40.4	5.440	39.6
3.620	40.9	4.540	40.4	5.460	39.6
3.640	40.9	4.560	40.4	5.480	39.6
3.660	40.4	4.580	40.4	5.500	39.6
3.680	40.4	4.600	40.0	5.520	39.6
3.700	40.4	4.620	39.6	5.540	39.6
3.720	40.4	4.640	39.6	5.560	39.6
3.740	40.0	4.660	39.6	5.580	39.2
3.760	40.0	4.680	39.2	5.600	38.8
3.780	40.0	4.700	39.2	5.620	38.8
3.800	40.0	4.720	39.2	5.640	38.4
3.820	40.0	4.740	39.2	5.660	38.4
3.840	40.0	4.760	39.2	5.680	38.4
3.860	40.0	4.780	39.2	5.700	38.4
3.880	40.0	4.800	39.2	5.720	38.4
3.900	40.4	4.820	39.2	5.740	38.4
3.920	40.9	4.840	39.2	5.760	38.4
3.940	40.9	4.860	39.6	5.780	38.4
3.960	40.9	4.880	40.0	5.800	38.4
3.980	40.9	4.900	40.0	5.820	38.4
4.000	41.3	4.920	40.4	5.840	38.4
4.020	41.3	4.940	40.4	5.860	38.4
4.040	41.3	4.960	40.4	5.880	38.8
4.060	41.3	4.980	40.4	5.900	39.2
4.080	41.3	5.000	40.4	5.920	39.6
4.100	41.3	5.020	40.4	5.940	40.0
4.120	40.9	5.040	40.4	5.960	40.4
4.140	40.9	5.060	40.4	5.980	40.4
4.160	40.9	5.080	40.4		
4.180	40.9	5.100	40.4		
4.200	40.9	5.120	40.4		
4.220	40.9	5.140	40.4		
4.240	40.9	5.160	40.4		
4.260	40.9	5.180	40.4		

Mix 1 R-10-12 Air Temperature Profile

Temperature Logging Started: 1230 on 5/23/96

Stopped: 1045 on 5/28/96

<u>Time</u> <u>(days)</u>	<u>Temperature</u> <u>(*C)</u>	<u>Time</u> <u>(days)</u>	<u>Temperature</u> <u>(*C)</u>	<u>Time</u> <u>(days)</u>	<u>Temperature</u> <u>(*C)</u>	<u>Time</u> <u>(days)</u>	<u>Temperature</u> <u>(*C)</u>
				1.680	24.8	2.520	23.4
				1.700	25.2	2.540	23.7
				1.720	25.2	2.560	24.1
				1.740	25.2	2.580	24.5
				1.760	25.2	2.600	24.5
				1.780	25.5	2.620	24.8
				1.800	24.5	2.640	24.8
				1.820	23.7	2.660	25.2
				1.840	23.4	2.680	25.2
		1.020	23.4	1.860	23.0	2.700	25.5
		1.040	23.4	1.880	23.0	2.720	25.5
		1.060	23.0	1.900	23.0	2.740	25.5
		1.080	23.0	1.920	23.7	2.760	25.5
		1.100	23.0	1.940	23.4	2.780	24.5
		1.120	23.0	1.960	23.4	2.800	24.1
		1.140	23.0	1.980	23.0	2.820	23.7
		1.160	23.0	2.000	23.0	2.840	23.4
		1.180	23.0	2.020	23.0	2.860	23.4
		1.200	23.0	2.040	23.0	2.880	23.0
		1.220	23.0	2.060	23.0	2.900	23.0
		1.240	23.0	2.080	22.7	2.920	23.0
		1.260	23.0	2.100	22.7	2.940	23.0
		1.280	23.0	2.120	22.7	2.960	23.0
		1.300	23.0	2.140	22.7	2.980	23.0
		1.320	22.7	2.160	22.7	3.000	23.0
		1.340	22.7	2.180	22.7	3.020	23.0
		1.360	22.7	2.200	22.7	3.040	23.0
		1.380	22.7	2.220	22.7	3.060	23.0
		1.400	22.7	2.240	22.7	3.080	23.0
		1.420	22.7	2.260	22.7	3.100	23.0
		1.440	22.7	2.280	22.7	3.120	23.0
		1.460	22.3	2.300	22.7	3.140	23.0
		1.480	22.3	2.320	22.7	3.160	23.0
		1.500	22.7	2.340	22.7	3.180	23.0
		1.520	23.4	2.360	22.7	3.200	23.0
		1.540	23.4	2.380	22.7	3.220	23.0
		1.560	23.7	2.400	22.7	3.240	23.0
		1.580	24.1	2.420	22.7	3.260	23.0
		1.600	24.5	2.440	22.7	3.280	23.0
		1.620	24.5	2.460	22.7	3.300	23.0
		1.640	24.8	2.480	22.7	3.320	23.0
		1.660	24.8	2.500	23.0	3.340	23.0

Time (days)	Temperature (*C)	Time (days)	Temperature (*C)	Time (days)	Temperature (*C)
3.360	23.0	4.280	23.0	5.200	22.7
3.380	23.0	4.300	23.0	5.220	22.7
3.400	22.7	4.320	23.0	5.240	22.7
3.420	22.7	4.340	23.0	5.260	22.7
3.440	22.7	4.360	23.0	5.280	22.7
3.460	22.7	4.380	23.0	5.300	22.3
3.480	22.7	4.400	23.0	5.320	22.7
3.500	23.0	4.420	22.7	5.340	22.3
3.520	23.7	4.440	22.7	5.360	22.3
3.540	24.1	4.460	22.7	5.380	22.3
3.560	24.5	4.480	22.7	5.400	22.3
3.580	24.8	4.500	23.0	5.420	22.3
3.600	24.8	4.520	23.7	5.440	22.3
3.620	24.8	4.540	24.1	5.460	22.3
3.640	25.2	4.560	24.5	5.480	22.3
3.660	25.2	4.580	24.8	5.500	22.7
3.680	25.5	4.600	24.8	5.520	23.4
3.700	25.5	4.620	25.2	5.540	23.7
3.720	25.5	4.640	25.2	5.560	24.1
3.740	25.5	4.660	25.2	5.580	24.5
3.760	25.5	4.680	25.5	5.600	24.8
3.780	25.5	4.700	25.5	5.620	24.8
3.800	24.5	4.720	25.5	5.640	25.2
3.820	24.1	4.740	25.5	5.660	25.2
3.840	23.7	4.760	24.5	5.680	25.5
3.860	23.4	4.780	24.1	5.700	25.5
3.880	23.4	4.800	23.7	5.720	25.9
3.900	23.4	4.820	23.4	5.740	25.9
3.920	23.4	4.840	23.4	5.760	25.9
3.940	23.0	4.860	23.0	5.780	25.9
3.960	23.0	4.880	23.0	5.800	24.5
3.980	23.0	4.900	22.7	5.820	24.1
4.000	23.0	4.920	22.7	5.840	23.7
4.020	23.0	4.940	22.7	5.860	23.4
4.040	23.0	4.960	22.7	5.880	23.4
4.060	23.0	4.980	22.7	5.900	23.0
4.080	23.0	5.000	22.7	5.920	23.0
4.100	23.4	5.020	22.7	5.940	23.0
4.120	23.4	5.040	22.7	5.960	23.0
4.140	23.4	5.060	22.7	5.980	23.0
4.160	23.4	5.080	22.7		
4.180	23.4	5.100	22.7		
4.200	23.4	5.120	22.7		
4.220	23.4	5.140	22.7		
4.240	23.4	5.160	22.7		
4.260	23.4	5.180	22.7		

Mix 2 R-01-3.5B Air Temperature Profile

Temperature Logging Started: 0100 on 5/31/96

Stopped: 0100 on 6/6/96

<u>Time</u> <u>(days)</u>	<u>Temperature</u> <u>(*C)</u>	<u>Time</u> <u>(days)</u>	<u>Temperature</u> <u>(*C)</u>	<u>Time</u> <u>(days)</u>	<u>Temperature</u> <u>(*C)</u>	<u>Time</u> <u>(days)</u>	<u>Temperature</u> <u>(*C)</u>
.000	24.1	.840	21.6	1.680	21.6	2.520	22.0
.020	24.1	.860	21.6	1.700	21.6	2.540	22.0
.040	24.8	.880	21.6	1.720	21.6	2.560	21.6
.060	25.2	.900	21.6	1.740	21.6	2.580	21.6
.080	25.2	.920	21.6	1.760	21.3	2.600	21.6
.100	25.5	.940	21.6	1.780	21.3	2.620	21.6
.120	25.5	.960	21.6	1.800	21.3	2.640	21.6
.140	25.9	.980	23.0	1.820	21.3	2.660	21.6
.160	25.9	1.000	23.7	1.840	21.3	2.680	21.6
.180	26.2	1.020	24.5	1.860	21.3	2.700	21.3
.200	26.2	1.040	24.8	1.880	21.3	2.720	21.3
.220	26.2	1.060	25.2	1.900	20.9	2.740	21.3
.240	26.2	1.080	25.5	1.920	20.9	2.760	21.3
.260	24.5	1.100	25.5	1.940	20.9	2.780	20.9
.280	23.4	1.120	25.9	1.960	20.9	2.800	20.9
.300	22.7	1.140	25.9	1.980	22.7	2.820	20.9
.320	22.3	1.160	26.2	2.000	23.4	2.840	20.6
.340	22.0	1.180	26.2	2.020	23.7	2.860	20.6
.360	21.6	1.200	26.6	2.040	24.5	2.880	20.6
.380	21.6	1.220	26.6	2.060	24.8	2.900	20.6
.400	21.3	1.240	24.8	2.080	25.2	2.920	20.2
.420	21.6	1.260	23.7	2.100	25.2	2.940	20.2
.440	21.6	1.280	23.0	2.120	25.5	2.960	20.2
.460	21.6	1.300	22.7	2.140	25.9	2.980	22.0
.480	21.6	1.320	22.3	2.160	25.9	3.000	22.7
.500	21.6	1.340	22.3	2.180	26.2	3.020	23.0
.520	21.6	1.360	22.0	2.200	26.2	3.040	23.4
.540	21.6	1.380	22.0	2.220	26.2	3.060	23.7
.560	21.6	1.400	22.0	2.240	24.8	3.080	24.1
.580	21.6	1.420	22.0	2.260	23.4	3.100	24.5
.600	21.6	1.440	22.0	2.280	23.0	3.120	24.8
.620	21.6	1.460	22.0	2.300	22.3	3.140	24.8
.640	21.6	1.480	21.6	2.320	22.0	3.160	25.2
.660	21.6	1.500	21.6	2.340	22.0	3.180	25.2
.680	21.6	1.520	21.6	2.360	22.0	3.200	23.4
.700	21.6	1.540	22.0	2.380	22.0	3.220	22.3
.720	21.6	1.560	22.0	2.400	22.0	3.240	21.6
.740	22.0	1.580	22.0	2.420	22.0	3.260	21.3
.760	22.0	1.600	22.0	2.440	22.0	3.280	21.3
.780	22.0	1.620	21.6	2.460	22.0	3.300	20.9
.800	22.0	1.640	21.6	2.480	22.0	3.320	20.6
.820	22.0	1.660	21.6	2.500	22.0	3.340	20.6

Time (days)	Temperature (*C)
3.360	20.2
3.380	20.6
3.400	20.6
3.420	20.6
3.440	20.6
3.460	20.6
3.480	20.6
3.500	20.6
3.520	20.9
3.540	20.9
3.560	20.9
3.580	20.9
3.600	20.9
3.620	20.9
3.640	20.9
3.660	20.9
3.680	20.9
3.700	20.9
3.720	20.9
3.740	20.9
3.760	20.6
3.780	20.6
3.800	20.6
3.820	20.6
3.840	20.6
3.860	20.6
3.880	20.6
3.900	20.6
3.920	20.6
3.940	20.2
3.960	20.6
3.980	22.0
4.000	22.7
4.020	23.4
4.040	23.7
4.060	24.1

Mix 2 R-01-3.5B Temperature Profile

Temperature Logging Started: 0100 on 5/31/96

Stopped: 0100 on 6/6/96

<u>Time</u> <u>(days)</u>	<u>Temperature</u> <u>(*C)</u>	<u>Time</u> <u>(days)</u>	<u>Temperature</u> <u>(*C)</u>	<u>Time</u> <u>(days)</u>	<u>Temperature</u> <u>(*C)</u>	<u>Time</u> <u>(days)</u>	<u>Temperature</u> <u>(*C)</u>
.000	26.9	.840	26.9	1.680	29.0	2.520	29.4
.020	26.9	.860	26.9	1.700	29.0	2.540	29.0
.040	26.9	.880	26.9	1.720	29.0	2.560	29.0
.060	26.9	.900	26.9	1.740	29.0	2.580	29.0
.080	27.2	.920	26.9	1.760	28.7	2.600	29.0
.100	27.2	.940	26.9	1.780	28.7	2.620	28.7
.120	27.6	.960	26.9	1.800	28.7	2.640	28.7
.140	27.6	.980	26.9	1.820	28.7	2.660	28.7
.160	27.6	1.000	26.9	1.840	28.7	2.680	28.7
.180	27.9	1.020	27.2	1.860	28.7	2.700	28.3
.200	27.9	1.040	27.2	1.880	28.7	2.720	28.3
.220	27.9	1.060	27.2	1.900	28.7	2.740	28.3
.240	28.3	1.080	27.6	1.920	28.7	2.760	28.3
.260	28.3	1.100	27.6	1.940	28.3	2.780	27.9
.280	28.3	1.120	27.9	1.960	28.3	2.800	27.9
.300	28.3	1.140	27.9	1.980	28.3	2.820	27.9
.320	28.3	1.160	28.3	2.000	28.3	2.840	27.6
.340	28.3	1.180	28.7	2.020	28.3	2.860	27.6
.360	27.9	1.200	28.7	2.040	28.3	2.880	27.6
.380	27.9	1.220	29.0	2.060	28.7	2.900	27.2
.400	27.9	1.240	29.4	2.080	28.7	2.920	27.2
.420	27.6	1.260	29.4	2.100	28.7	2.940	27.2
.440	27.6	1.280	29.4	2.120	29.0	2.960	26.9
.460	27.6	1.300	29.8	2.140	29.0	2.980	26.9
.480	27.2	1.320	29.8	2.160	29.4	3.000	26.9
.500	27.2	1.340	29.8	2.180	29.4	3.020	26.9
.520	27.2	1.360	29.4	2.200	29.8	3.040	26.9
.540	27.2	1.380	29.4	2.220	29.8	3.060	26.9
.560	27.2	1.400	29.4	2.240	30.1	3.080	26.9
.580	27.2	1.420	29.4	2.260	30.1	3.100	26.9
.600	26.9	1.440	29.4	2.280	30.1	3.120	26.9
.620	26.9	1.460	29.4	2.300	30.1	3.140	27.2
.640	26.9	1.480	29.4	2.320	30.1	3.160	27.2
.660	26.9	1.500	29.0	2.340	30.1	3.180	27.2
.680	26.9	1.520	29.0	2.360	30.1	3.200	27.2
.700	26.9	1.540	29.0	2.380	29.8	3.220	27.6
.720	26.9	1.560	29.0	2.400	29.8	3.240	27.6
.740	26.9	1.580	29.0	2.420	29.8	3.260	27.6
.760	26.9	1.600	29.0	2.440	29.8	3.280	27.2
.780	26.9	1.620	29.0	2.460	29.4	3.300	27.2
.800	26.9	1.640	29.0	2.480	29.4	3.320	27.2
.820	26.9	1.660	29.0	2.500	29.4	3.340	26.9

Time (days)	Temperature (*C)	Time (days)	Temperature (*C)	Time (days)	Temperature (*C)
3.360	26.9	4.280	25.8	5.200	25.8
3.380	26.5	4.300	25.4	5.220	25.8
3.400	26.5	4.320	25.4	5.240	26.1
3.420	26.5	4.340	25.4	5.260	26.1
3.440	26.1	4.360	25.4	5.280	26.1
3.460	26.1	4.380	25.1	5.300	26.1
3.480	25.8	4.400	25.1	5.320	26.1
3.500	25.8	4.420	25.1	5.340	26.1
3.520	25.8	4.440	24.7	5.360	25.8
3.540	25.8	4.460	24.7	5.380	25.8
3.560	25.4	4.480	24.7	5.400	25.8
3.580	25.4	4.500	24.7	5.420	25.8
3.600	25.4	4.520	24.4	5.440	25.4
3.620	25.4	4.540	24.4	5.460	25.4
3.640	25.1	4.560	24.4	5.480	25.4
3.660	25.1	4.580	24.4	5.500	25.4
3.680	25.1	4.600	24.4	5.520	25.4
3.700	25.1	4.620	24.4	5.540	25.1
3.720	25.1	4.640	24.4	5.560	25.1
3.740	25.1	4.660	24.4	5.580	25.1
3.760	24.7	4.680	24.4	5.600	25.1
3.780	24.7	4.700	24.4	5.620	25.1
3.800	24.7	4.720	24.4	5.640	24.7
3.820	24.7	4.740	24.0	5.660	24.7
3.840	24.7	4.760	24.0	5.680	24.7
3.860	24.7	4.780	24.0	5.700	24.7
3.880	24.4	4.800	24.0	5.720	24.4
3.900	24.4	4.820	24.0	5.740	24.4
3.920	24.4	4.840	24.0	5.760	24.4
3.940	24.4	4.860	24.0	5.780	24.4
3.960	24.4	4.880	24.0	5.800	24.0
3.980	24.4	4.900	24.0	5.820	24.0
4.000	24.0	4.920	24.0	5.840	24.0
4.020	24.4	4.940	24.0	5.860	24.0
4.040	24.4	4.960	24.0	5.880	24.0
4.060	24.4	4.980	24.0	5.900	23.6
4.080	24.4	5.000	24.0	5.920	23.6
4.100	24.7	5.020	24.0	5.940	23.6
4.120	24.7	5.040	24.0	5.960	23.6
4.140	25.1	5.060	24.4	5.980	23.3
4.160	25.1	5.080	24.4		
4.180	25.1	5.100	24.7		
4.200	25.4	5.120	24.7		
4.220	25.4	5.140	25.1		
4.240	25.8	5.160	25.4		
4.260	25.8	5.180	25.4		

Mix 2 R-01-6.5B Temperature Profile

Temperature Logging Started: 0100 on 5/31/96

Stopped: 0100 on 6/6/96

<u>Time</u> <u>(days)</u>	<u>Temperature</u> <u>(*C)</u>	<u>Time</u> <u>(days)</u>	<u>Temperature</u> <u>(*C)</u>	<u>Time</u> <u>(days)</u>	<u>Temperature</u> <u>(*C)</u>	<u>Time</u> <u>(days)</u>	<u>Temperature</u> <u>(*C)</u>
.000	24.3	.840	32.3	1.680	37.0	2.520	36.2
.020	26.8	.860	32.7	1.700	37.0	2.540	36.2
.040	26.8	.880	32.7	1.720	37.0	2.560	36.2
.060	27.2	.900	32.7	1.740	37.0	2.580	35.8
.080	27.2	.920	32.7	1.760	37.0	2.600	35.8
.100	27.5	.940	33.1	1.780	37.0	2.620	35.8
.120	27.9	.960	33.1	1.800	37.0	2.640	35.8
.140	27.9	.980	33.1	1.820	36.6	2.660	35.8
.160	28.2	1.000	33.1	1.840	36.6	2.680	35.4
.180	28.6	1.020	33.4	1.860	36.6	2.700	35.4
.200	28.6	1.040	33.4	1.880	36.6	2.720	35.4
.220	29.0	1.060	33.4	1.900	36.6	2.740	35.4
.240	29.3	1.080	33.8	1.920	36.6	2.760	35.0
.260	29.3	1.100	33.8	1.940	36.6	2.780	35.0
.280	29.7	1.120	34.2	1.960	36.6	2.800	35.0
.300	29.7	1.140	34.2	1.980	36.2	2.820	35.0
.320	30.1	1.160	34.6	2.000	36.2	2.840	34.6
.340	30.1	1.180	34.6	2.020	36.2	2.860	34.6
.360	30.4	1.200	35.0	2.040	36.2	2.880	34.6
.380	30.4	1.220	35.4	2.060	36.2	2.900	34.2
.400	30.4	1.240	35.4	2.080	36.2	2.920	34.2
.420	30.8	1.260	35.8	2.100	36.2	2.940	34.2
.440	30.8	1.280	35.8	2.120	36.2	2.960	34.2
.460	30.8	1.300	36.2	2.140	36.2	2.980	33.8
.480	30.8	1.320	36.2	2.160	36.2	3.000	33.8
.500	30.8	1.340	36.2	2.180	36.6	3.020	33.8
.520	30.8	1.360	36.6	2.200	36.6	3.040	33.4
.540	31.2	1.380	36.6	2.220	36.6	3.060	33.4
.560	31.2	1.400	36.6	2.240	36.6	3.080	33.4
.580	31.2	1.420	36.6	2.260	37.0	3.100	33.4
.600	31.2	1.440	36.6	2.280	37.0	3.120	33.4
.620	31.5	1.460	36.6	2.300	37.0	3.140	33.4
.640	31.5	1.480	36.6	2.320	37.0	3.160	33.4
.660	31.5	1.500	37.0	2.340	37.0	3.180	33.4
.680	31.5	1.520	37.0	2.360	37.0	3.200	33.4
.700	31.9	1.540	37.0	2.380	37.0	3.220	33.4
.720	31.9	1.560	37.0	2.400	36.6	3.240	33.4
.740	31.9	1.580	37.0	2.420	36.6	3.260	33.4
.760	31.9	1.600	37.0	2.440	36.6	3.280	33.4
.780	32.3	1.620	37.0	2.460	36.6	3.300	33.4
.800	32.3	1.640	37.0	2.480	36.2	3.320	33.4
.820	32.3	1.660	37.0	2.500	36.2	3.340	33.4

Time (days)	Temperature (*C)	Time (days)	Temperature (*C)	Time (days)	Temperature (*C)
3.360	33.4	4.280	30.8	5.200	29.7
3.380	33.1	4.300	30.8	5.220	29.7
3.400	33.1	4.320	30.8	5.240	29.7
3.420	33.1	4.340	30.8	5.260	30.1
3.440	32.7	4.360	30.8	5.280	30.1
3.460	32.7	4.380	30.4	5.300	30.1
3.480	32.7	4.400	30.4	5.320	30.1
3.500	32.3	4.420	30.4	5.340	30.1
3.520	32.3	4.440	30.4	5.360	30.1
3.540	32.3	4.460	30.1	5.380	30.1
3.560	32.3	4.480	30.1	5.400	30.1
3.580	31.9	4.500	30.1	5.420	30.1
3.600	31.9	4.520	30.1	5.440	30.1
3.620	31.9	4.540	30.1	5.460	29.7
3.640	31.5	4.560	29.7	5.480	29.7
3.660	31.5	4.580	29.7	5.500	29.7
3.680	31.5	4.600	29.7	5.520	29.7
3.700	31.5	4.620	29.7	5.540	29.7
3.720	31.5	4.640	29.7	5.560	29.7
3.740	31.2	4.660	29.7	5.580	29.7
3.760	31.2	4.680	29.7	5.600	29.7
3.780	31.2	4.700	29.7	5.620	29.3
3.800	31.2	4.720	29.3	5.640	29.3
3.820	31.2	4.740	29.3	5.660	29.3
3.840	30.8	4.760	29.3	5.680	29.3
3.860	30.8	4.780	29.3	5.700	29.3
3.880	30.8	4.800	29.3	5.720	29.3
3.900	30.8	4.820	29.3	5.740	29.3
3.920	30.8	4.840	29.3	5.760	29.3
3.940	30.4	4.860	29.3	5.780	29.0
3.960	30.4	4.880	29.3	5.800	29.0
3.980	30.4	4.900	29.0	5.820	29.0
4.000	30.4	4.920	29.0	5.840	29.0
4.020	30.1	4.940	29.0	5.860	29.0
4.040	30.1	4.960	29.0	5.880	29.0
4.060	30.1	4.980	29.0	5.900	28.6
4.080	30.1	5.000	29.0	5.920	28.6
4.100	30.1	5.020	29.0	5.940	28.6
4.120	30.1	5.040	29.0	5.960	28.6
4.140	30.4	5.060	29.0	5.980	28.6
4.160	30.4	5.080	29.0		
4.180	30.4	5.100	29.0		
4.200	30.4	5.120	29.0		
4.220	30.4	5.140	29.3		
4.240	30.8	5.160	29.3		
4.260	30.8	5.180	29.3		

Mix 2 R-01-8.5B Temperature Profile

Temperature Logging Started: 0100 on 5/31/96

Stopped: 0100 on 6/6/96

<u>Time</u> <u>(days)</u>	<u>Temperature</u> <u>(*C)</u>	<u>Time</u> <u>(days)</u>	<u>Temperature</u> <u>(*C)</u>	<u>Time</u> <u>(days)</u>	<u>Temperature</u> <u>(*C)</u>	<u>Time</u> <u>(days)</u>	<u>Temperature</u> <u>(*C)</u>
.000	23.7	.840	35.6	1.680	40.4	2.520	40.0
.020	27.3	.860	35.6	1.700	40.4	2.540	40.0
.040	27.3	.880	36.0	1.720	40.4	2.560	40.0
.060	27.7	.900	36.0	1.740	40.4	2.580	40.0
.080	27.7	.920	36.0	1.760	40.4	2.600	40.0
.100	28.0	.940	36.4	1.780	40.4	2.620	39.6
.120	28.0	.960	36.4	1.800	40.4	2.640	39.6
.140	28.4	.980	36.7	1.820	40.4	2.660	39.6
.160	28.4	1.000	36.7	1.840	40.4	2.680	39.6
.180	28.8	1.020	36.7	1.860	40.4	2.700	39.6
.200	29.1	1.040	37.1	1.880	40.4	2.720	39.6
.220	29.5	1.060	37.1	1.900	40.4	2.740	39.6
.240	29.5	1.080	37.1	1.920	40.0	2.760	39.6
.260	29.9	1.100	37.5	1.940	40.0	2.780	39.6
.280	30.2	1.120	37.5	1.960	40.0	2.800	39.6
.300	30.2	1.140	37.5	1.980	40.0	2.820	39.2
.320	30.6	1.160	38.0	2.000	40.0	2.840	39.2
.340	31.0	1.180	38.0	2.020	40.0	2.860	39.2
.360	31.0	1.200	38.4	2.040	40.0	2.880	39.2
.380	31.4	1.220	38.4	2.060	40.0	2.900	39.2
.400	31.7	1.240	38.8	2.080	40.0	2.920	39.2
.420	31.7	1.260	38.8	2.100	40.0	2.940	38.8
.440	32.1	1.280	39.2	2.120	40.0	2.960	38.8
.460	32.1	1.300	39.2	2.140	40.0	2.980	38.8
.480	32.5	1.320	39.6	2.160	40.0	3.000	38.8
.500	32.5	1.340	39.6	2.180	40.0	3.020	38.8
.520	32.9	1.360	39.6	2.200	40.0	3.040	38.4
.540	32.9	1.380	40.0	2.220	40.0	3.060	38.4
.560	33.2	1.400	40.0	2.240	40.0	3.080	38.4
.580	33.2	1.420	40.0	2.260	40.0	3.100	38.4
.600	33.6	1.440	40.0	2.280	40.0	3.120	38.4
.620	33.6	1.460	40.0	2.300	40.0	3.140	38.4
.640	33.6	1.480	40.0	2.320	40.0	3.160	38.4
.660	34.0	1.500	40.0	2.340	40.4	3.180	38.4
.680	34.0	1.520	40.4	2.360	40.4	3.200	38.4
.700	34.4	1.540	40.4	2.380	40.4	3.220	38.4
.720	34.4	1.560	40.4	2.400	40.4	3.240	38.4
.740	34.8	1.580	40.4	2.420	40.0	3.260	38.4
.760	34.8	1.600	40.4	2.440	40.0	3.280	38.4
.780	35.2	1.620	40.4	2.460	40.0	3.300	38.4
.800	35.2	1.640	40.4	2.480	40.0	3.320	38.4
.820	35.2	1.660	40.4	2.500	40.0	3.340	38.4

Time (days)	Temperature (*C)	Time (days)	Temperature (*C)	Time (days)	Temperature (*C)
3.360	38.0	4.280	35.6	5.200	33.6
3.380	38.0	4.300	35.6	5.220	33.6
3.400	38.0	4.320	35.6	5.240	33.6
3.420	38.0	4.340	35.6	5.260	33.6
3.440	38.0	4.360	35.2	5.280	33.6
3.460	37.5	4.380	35.2	5.300	33.6
3.480	37.5	4.400	35.2	5.320	33.6
3.500	37.5	4.420	35.2	5.340	33.6
3.520	37.5	4.440	35.2	5.360	33.6
3.540	37.1	4.460	35.2	5.380	33.6
3.560	37.1	4.480	34.8	5.400	33.6
3.580	37.1	4.500	34.8	5.420	33.6
3.600	37.1	4.520	34.8	5.440	33.6
3.620	36.7	4.540	34.8	5.460	33.6
3.640	36.7	4.560	34.8	5.480	33.6
3.660	36.7	4.580	34.4	5.500	33.6
3.680	36.7	4.600	34.4	5.520	33.6
3.700	36.7	4.620	34.4	5.540	33.2
3.720	36.7	4.640	34.4	5.560	33.2
3.740	36.4	4.660	34.4	5.580	33.2
3.760	36.4	4.680	34.4	5.600	33.2
3.780	36.4	4.700	34.4	5.620	33.2
3.800	36.4	4.720	34.0	5.640	33.2
3.820	36.4	4.740	34.0	5.660	33.2
3.840	36.4	4.760	34.0	5.680	33.2
3.860	36.4	4.780	34.0	5.700	33.2
3.880	36.0	4.800	34.0	5.720	33.2
3.900	36.0	4.820	34.0	5.740	33.2
3.920	36.0	4.840	34.0	5.760	32.9
3.940	36.0	4.860	34.0	5.780	32.9
3.960	36.0	4.880	34.0	5.800	32.9
3.980	35.6	4.900	34.0	5.820	32.9
4.000	35.6	4.920	33.6	5.840	32.9
4.020	35.6	4.940	33.6	5.860	32.9
4.040	35.6	4.960	33.6	5.880	32.9
4.060	35.6	4.980	33.6	5.900	32.5
4.080	35.6	5.000	33.6	5.920	32.5
4.100	35.6	5.020	33.6	5.940	32.5
4.120	35.2	5.040	33.6	5.960	32.5
4.140	35.2	5.060	33.2	5.980	32.5
4.160	35.2	5.080	33.2		
4.180	35.2	5.100	33.2		
4.200	35.2	5.120	33.2		
4.220	35.2	5.140	33.2		
4.240	35.2	5.160	33.2		
4.260	35.2	5.180	33.2		

Mix 2 R-04-12 Temperature Profile

Temperature Logging

Started: 0100 on 5/31/96

Stopped: 0100 on 6/6/96

<u>Time</u> <u>(days)</u>	<u>Temperature</u> <u>(*C)</u>	<u>Time</u> <u>(days)</u>	<u>Temperature</u> <u>(*C)</u>	<u>Time</u> <u>(days)</u>	<u>Temperature</u> <u>(*C)</u>	<u>Time</u> <u>(days)</u>	<u>Temperature</u> <u>(*C)</u>
.000	23.7	.840	35.6	1.680	40.4	2.520	40.0
.020	27.3	.860	35.6	1.700	40.4	2.540	40.0
.040	27.3	.880	36.0	1.720	40.4	2.560	40.0
.060	27.7	.900	36.0	1.740	40.4	2.580	40.0
.080	27.7	.920	36.0	1.760	40.4	2.600	40.0
.100	28.0	.940	36.4	1.780	40.4	2.620	39.6
.120	28.0	.960	36.4	1.800	40.4	2.640	39.6
.140	28.4	.980	36.7	1.820	40.4	2.660	39.6
.160	28.4	1.000	36.7	1.840	40.4	2.680	39.6
.180	28.8	1.020	36.7	1.860	40.4	2.700	39.6
.200	29.1	1.040	37.1	1.880	40.4	2.720	39.6
.220	29.5	1.060	37.1	1.900	40.4	2.740	39.6
.240	29.5	1.080	37.1	1.920	40.0	2.760	39.6
.260	29.9	1.100	37.5	1.940	40.0	2.780	39.6
.280	30.2	1.120	37.5	1.960	40.0	2.800	39.6
.300	30.2	1.140	37.5	1.980	40.0	2.820	39.2
.320	30.6	1.160	38.0	2.000	40.0	2.840	39.2
.340	31.0	1.180	38.0	2.020	40.0	2.860	39.2
.360	31.0	1.200	38.4	2.040	40.0	2.880	39.2
.380	31.4	1.220	38.4	2.060	40.0	2.900	39.2
.400	31.7	1.240	38.8	2.080	40.0	2.920	39.2
.420	31.7	1.260	38.8	2.100	40.0	2.940	38.8
.440	32.1	1.280	39.2	2.120	40.0	2.960	38.8
.460	32.1	1.300	39.2	2.140	40.0	2.980	38.8
.480	32.5	1.320	39.6	2.160	40.0	3.000	38.8
.500	32.5	1.340	39.6	2.180	40.0	3.020	38.8
.520	32.9	1.360	39.6	2.200	40.0	3.040	38.4
.540	32.9	1.380	40.0	2.220	40.0	3.060	38.4
.560	33.2	1.400	40.0	2.240	40.0	3.080	38.4
.580	33.2	1.420	40.0	2.260	40.0	3.100	38.4
.600	33.6	1.440	40.0	2.280	40.0	3.120	38.4
.620	33.6	1.460	40.0	2.300	40.0	3.140	38.4
.640	33.6	1.480	40.0	2.320	40.0	3.160	38.4
.660	34.0	1.500	40.0	2.340	40.4	3.180	38.4
.680	34.0	1.520	40.4	2.360	40.4	3.200	38.4
.700	34.4	1.540	40.4	2.380	40.4	3.220	38.4
.720	34.4	1.560	40.4	2.400	40.4	3.240	38.4
.740	34.8	1.580	40.4	2.420	40.0	3.260	38.4
.760	34.8	1.600	40.4	2.440	40.0	3.280	38.4
.780	35.2	1.620	40.4	2.460	40.0	3.300	38.4
.800	35.2	1.640	40.4	2.480	40.0	3.320	38.4
.820	35.2	1.660	40.4	2.500	40.0	3.340	38.4

Time (d)	Temperature (*C)	Time (d)	Temperature (*C)	Time (d)	Temperature (*C)
3.360	38.0	4.280	35.6	5.200	33.6
3.380	38.0	4.300	35.6	5.220	33.6
3.400	38.0	4.320	35.6	5.240	33.6
3.420	38.0	4.340	35.6	5.260	33.6
3.440	38.0	4.360	35.2	5.280	33.6
3.460	37.5	4.380	35.2	5.300	33.6
3.480	37.5	4.400	35.2	5.320	33.6
3.500	37.5	4.420	35.2	5.340	33.6
3.520	37.5	4.440	35.2	5.360	33.6
3.540	37.1	4.460	35.2	5.380	33.6
3.560	37.1	4.480	34.8	5.400	33.6
3.580	37.1	4.500	34.8	5.420	33.6
3.600	37.1	4.520	34.8	5.440	33.6
3.620	36.7	4.540	34.8	5.460	33.6
3.640	36.7	4.560	34.8	5.480	33.6
3.660	36.7	4.580	34.4	5.500	33.6
3.680	36.7	4.600	34.4	5.520	33.6
3.700	36.7	4.620	34.4	5.540	33.2
3.720	36.7	4.640	34.4	5.560	33.2
3.740	36.4	4.660	34.4	5.580	33.2
3.760	36.4	4.680	34.4	5.600	33.2
3.780	36.4	4.700	34.4	5.620	33.2
3.800	36.4	4.720	34.0	5.640	33.2
3.820	36.4	4.740	34.0	5.660	33.2
3.840	36.4	4.760	34.0	5.680	33.2
3.860	36.4	4.780	34.0	5.700	33.2
3.880	36.0	4.800	34.0	5.720	33.2
3.900	36.0	4.820	34.0	5.740	33.2
3.920	36.0	4.840	34.0	5.760	32.9
3.940	36.0	4.860	34.0	5.780	32.9
3.960	36.0	4.880	34.0	5.800	32.9
3.980	35.6	4.900	34.0	5.820	32.9
4.000	35.6	4.920	33.6	5.840	32.9
4.020	35.6	4.940	33.6	5.860	32.9
4.040	35.6	4.960	33.6	5.880	32.9
4.060	35.6	4.980	33.6	5.900	32.5
4.080	35.6	5.000	33.6	5.920	32.5
4.100	35.6	5.020	33.6	5.940	32.5
4.120	35.2	5.040	33.6	5.960	32.5
4.140	35.2	5.060	33.2	5.980	32.5
4.160	35.2	5.080	33.2		
4.180	35.2	5.100	33.2		
4.200	35.2	5.120	33.2		
4.220	35.2	5.140	33.2		
4.240	35.2	5.160	33.2		
4.260	35.2	5.180	33.2		

Mix 2 R-07-12 Temperature Profile

Temperature Logging Started: 0100 on 5/31/96

Stopped: 0100 on 6/6/96

<u>Time</u> <u>(days)</u>	<u>Temperature</u> <u>(*C)</u>	<u>Time</u> <u>(days)</u>	<u>Temperature</u> <u>(*C)</u>	<u>Time</u> <u>(days)</u>	<u>Temperature</u> <u>(*C)</u>	<u>Time</u> <u>(days)</u>	<u>Temperature</u> <u>(*C)</u>
.000	23.7	.840	53.2	1.680	53.2	2.520	48.6
.020	31.7	.860	53.2	1.700	53.2	2.540	48.1
.040	32.5	.880	53.2	1.720	53.2	2.560	48.1
.060	32.9	.900	53.2	1.740	53.2	2.580	48.1
.080	33.6	.920	53.2	1.760	52.7	2.600	47.6
.100	34.4	.940	53.2	1.780	52.7	2.620	47.6
.120	35.2	.960	53.2	1.800	52.7	2.640	47.6
.140	36.0	.980	53.2	1.820	52.1	2.660	47.6
.160	36.7	1.000	53.2	1.840	52.1	2.680	47.1
.180	37.5	1.020	53.2	1.860	52.1	2.700	47.1
.200	38.4	1.040	53.2	1.880	52.1	2.720	47.1
.220	38.8	1.060	53.2	1.900	51.6	2.740	46.7
.240	39.6	1.080	53.2	1.920	51.6	2.760	46.7
.260	40.4	1.100	53.2	1.940	51.6	2.780	46.7
.280	41.3	1.120	53.2	1.960	51.6	2.800	46.2
.300	42.1	1.140	53.2	1.980	51.1	2.820	46.2
.320	43.0	1.160	53.7	2.000	51.1	2.840	46.2
.340	43.5	1.180	53.7	2.020	51.1	2.860	45.7
.360	44.4	1.200	53.7	2.040	50.6	2.880	45.7
.380	45.3	1.220	53.7	2.060	50.6	2.900	45.7
.400	45.7	1.240	53.7	2.080	50.6	2.920	45.3
.420	46.7	1.260	53.7	2.100	50.6	2.940	45.3
.440	47.6	1.280	53.7	2.120	50.6	2.960	44.8
.460	48.6	1.300	53.7	2.140	50.1	2.980	44.8
.480	49.1	1.320	54.3	2.160	50.1	3.000	44.8
.500	49.6	1.340	54.3	2.180	50.1	3.020	44.4
.520	50.1	1.360	54.3	2.200	50.1	3.040	44.4
.540	50.6	1.380	54.3	2.220	50.1	3.060	44.4
.560	51.1	1.400	54.3	2.240	50.1	3.080	43.9
.580	51.1	1.420	54.3	2.260	50.1	3.100	43.9
.600	51.6	1.440	54.3	2.280	50.1	3.120	43.9
.620	51.6	1.460	53.7	2.300	49.6	3.140	43.5
.640	51.6	1.480	53.7	2.320	49.6	3.160	43.5
.660	51.6	1.500	53.7	2.340	49.6	3.180	43.5
.680	52.1	1.520	53.7	2.360	49.6	3.200	43.5
.700	52.1	1.540	53.7	2.380	49.6	3.220	43.0
.720	52.1	1.560	53.7	2.400	49.6	3.240	43.0
.740	52.7	1.580	53.7	2.420	49.1	3.260	43.0
.760	52.7	1.600	53.7	2.440	49.1	3.280	43.0
.780	52.7	1.620	53.7	2.460	49.1	3.300	43.0
.800	52.7	1.640	53.2	2.480	48.6	3.320	42.6
.820	53.2	1.660	53.2	2.500	48.6	3.340	42.6

Time (days)	Temperature (*C)	Time (days)	Temperature (*C)	Time (days)	Temperature (*C)
3.360	42.6	4.280	36.4	5.200	32.9
3.380	42.1	4.300	36.4	5.220	32.9
3.400	42.1	4.320	36.4	5.240	32.9
3.420	42.1	4.340	36.0	5.260	32.9
3.440	41.7	4.360	36.0	5.280	32.9
3.460	41.7	4.380	36.0	5.300	32.9
3.480	41.3	4.400	36.0	5.320	33.2
3.500	41.3	4.420	36.0	5.340	33.2
3.520	41.3	4.440	36.0	5.360	33.2
3.540	40.9	4.460	35.6	5.380	33.2
3.560	40.9	4.480	35.6	5.400	33.2
3.580	40.4	4.500	35.6	5.420	32.9
3.600	40.4	4.520	35.2	5.440	32.9
3.620	40.4	4.540	35.2	5.460	32.9
3.640	40.0	4.560	35.2	5.480	32.9
3.660	40.0	4.580	35.2	5.500	32.9
3.680	39.6	4.600	34.8	5.520	32.9
3.700	39.6	4.620	34.8	5.540	32.9
3.720	39.6	4.640	34.8	5.560	32.5
3.740	39.2	4.660	34.4	5.580	32.5
3.760	39.2	4.680	34.4	5.600	32.5
3.780	39.2	4.700	34.4	5.620	32.5
3.800	38.8	4.720	34.4	5.640	32.5
3.820	38.8	4.740	34.0	5.660	32.5
3.840	38.8	4.760	34.0	5.680	32.5
3.860	38.4	4.780	34.0	5.700	32.1
3.880	38.4	4.800	34.0	5.720	32.1
3.900	38.4	4.820	34.0	5.740	32.1
3.920	38.0	4.840	33.6	5.760	32.1
3.940	38.0	4.860	33.6	5.780	32.1
3.960	37.5	4.880	33.6	5.800	32.1
3.980	37.5	4.900	33.6	5.820	31.7
4.000	37.5	4.920	33.2	5.840	31.7
4.020	37.1	4.940	33.2	5.860	31.7
4.040	37.1	4.960	33.2	5.880	31.7
4.060	37.1	4.980	33.2	5.900	31.7
4.080	36.7	5.000	33.2	5.920	31.4
4.100	36.7	5.020	32.9	5.940	31.4
4.120	36.7	5.040	32.9	5.960	31.4
4.140	36.7	5.060	32.9	5.980	31.4
4.160	36.4	5.080	32.9		
4.180	36.4	5.100	32.9		
4.200	36.4	5.120	32.9		
4.220	36.4	5.140	32.9		
4.240	36.4	5.160	32.9		
4.260	36.4	5.180	32.9		

Mix 2 R-10-12 Temperature Profile

Temperature Logging Started: 0100 on 5/31/96

Stopped: 0100 on 6/6/96

<u>Time</u> <u>(days)</u>	<u>Temperature</u> <u>(*C)</u>	<u>Time</u> <u>(days)</u>	<u>Temperature</u> <u>(*C)</u>	<u>Time</u> <u>(days)</u>	<u>Temperature</u> <u>(*C)</u>	<u>Time</u> <u>(days)</u>	<u>Temperature</u> <u>(*C)</u>
.000	30.2	.840	57.1	1.680	68.6	2.520	63.5
.020	31.4	.860	57.7	1.700	67.8	2.540	63.5
.040	32.1	.880	58.3	1.720	67.8	2.560	63.5
.060	32.5	.900	58.3	1.740	67.8	2.580	62.8
.080	32.5	.920	58.9	1.760	67.8	2.600	62.8
.100	32.9	.940	59.6	1.780	67.8	2.620	62.8
.120	32.9	.960	60.2	1.800	67.1	2.640	62.8
.140	32.9	.980	60.2	1.820	67.1	2.660	62.1
.160	33.2	1.000	60.8	1.840	67.1	2.680	62.1
.180	33.2	1.020	61.5	1.860	67.1	2.700	62.1
.200	33.6	1.040	62.1	1.880	67.1	2.720	62.1
.220	33.6	1.060	62.8	1.900	66.3	2.740	61.5
.240	34.0	1.080	62.8	1.920	66.3	2.760	61.5
.260	34.0	1.100	63.5	1.940	66.3	2.780	61.5
.280	34.8	1.120	64.2	1.960	66.3	2.800	60.8
.300	35.2	1.140	64.9	1.980	66.3	2.820	60.8
.320	35.6	1.160	64.9	2.000	66.3	2.840	60.2
.340	36.0	1.180	65.6	2.020	65.6	2.860	60.2
.360	36.4	1.200	66.3	2.040	65.6	2.880	60.2
.380	37.1	1.220	66.3	2.060	65.6	2.900	59.6
.400	37.5	1.240	67.1	2.080	65.6	2.920	59.6
.420	38.0	1.260	67.1	2.100	65.6	2.940	58.9
.440	40.0	1.280	67.1	2.120	65.6	2.960	58.9
.460	41.3	1.300	67.8	2.140	65.6	2.980	58.9
.480	42.6	1.320	67.8	2.160	64.9	3.000	58.3
.500	43.5	1.340	67.8	2.180	64.9	3.020	58.3
.520	44.8	1.360	68.6	2.200	64.9	3.040	58.3
.540	45.7	1.380	68.6	2.220	64.9	3.060	57.7
.560	47.1	1.400	68.6	2.240	64.9	3.080	57.7
.580	48.1	1.420	68.6	2.260	64.9	3.100	57.7
.600	48.6	1.440	68.6	2.280	64.9	3.120	57.1
.620	49.6	1.460	68.6	2.300	64.9	3.140	57.1
.640	50.6	1.480	68.6	2.320	64.9	3.160	56.5
.660	51.1	1.500	68.6	2.340	64.9	3.180	56.5
.680	51.6	1.520	68.6	2.360	64.9	3.200	56.5
.700	52.7	1.540	68.6	2.380	64.2	3.220	56.0
.720	53.2	1.560	68.6	2.400	64.2	3.240	56.0
.740	53.7	1.580	68.6	2.420	64.2	3.260	56.0
.760	54.8	1.600	68.6	2.440	64.2	3.280	56.0
.780	55.4	1.620	68.6	2.460	64.2	3.300	55.4
.800	56.0	1.640	68.6	2.480	64.2	3.320	55.4
.820	56.5	1.660	68.6	2.500	63.5	3.340	54.8

Time (days)	Temperature (*C)	Time (days)	Temperature (*C)	Time (days)	Temperature (*C)
3.360	54.8	4.280	49.1	5.200	44.8
3.380	54.3	4.300	48.6	5.220	44.8
3.400	54.3	4.320	48.6	5.240	44.8
3.420	53.7	4.340	48.6	5.260	44.8
3.440	53.7	4.360	48.6	5.280	44.8
3.460	53.7	4.380	48.1	5.300	44.8
3.480	53.2	4.400	48.1	5.320	44.8
3.500	53.2	4.420	48.1	5.340	44.8
3.520	52.7	4.440	48.1	5.360	44.4
3.540	52.7	4.460	48.1	5.380	44.4
3.560	52.1	4.480	48.1	5.400	44.4
3.580	52.1	4.500	47.6	5.420	44.4
3.600	52.1	4.520	47.6	5.440	44.4
3.620	52.1	4.540	47.6	5.460	44.4
3.640	51.6	4.560	47.6	5.480	44.4
3.660	51.6	4.580	47.1	5.500	44.4
3.680	51.6	4.600	47.1	5.520	44.4
3.700	51.6	4.620	47.1	5.540	43.9
3.720	51.6	4.640	47.1	5.560	43.9
3.740	51.1	4.660	46.7	5.580	43.9
3.760	51.1	4.680	46.7	5.600	43.9
3.780	51.1	4.700	46.7	5.620	43.9
3.800	51.1	4.720	46.7	5.640	43.5
3.820	50.6	4.740	46.7	5.660	43.5
3.840	50.6	4.760	46.2	5.680	43.5
3.860	50.6	4.780	46.2	5.700	43.5
3.880	50.6	4.800	46.2	5.720	43.5
3.900	50.1	4.820	46.2	5.740	43.5
3.920	50.1	4.840	46.2	5.760	43.0
3.940	50.1	4.860	45.7	5.780	43.0
3.960	50.1	4.880	45.7	5.800	43.0
3.980	49.6	4.900	45.7	5.820	43.0
4.000	49.6	4.920	45.7	5.840	43.0
4.020	49.6	4.940	45.7	5.860	43.0
4.040	49.6	4.960	45.7	5.880	42.6
4.060	49.6	4.980	45.3	5.900	42.6
4.080	49.6	5.000	45.3	5.920	42.6
4.100	49.6	5.020	45.3	5.940	42.6
4.120	49.6	5.040	45.3	5.960	42.6
4.140	49.6	5.060	45.3	5.980	42.6
4.160	49.1	5.080	45.3		
4.180	49.1	5.100	45.3		
4.200	49.1	5.120	45.3		
4.220	49.1	5.140	45.3		
4.240	49.1	5.160	44.8		
4.260	49.1	5.180	44.8		

Mix 2 R-10-12 Air Temperature Profile

Temperature Logging Started: 0100 on 5/31/96

Stopped: 0100 on 6/6/96

<u>Time</u> <u>(days)</u>	<u>Temperature</u> <u>(*C)</u>	<u>Time</u> <u>(days)</u>	<u>Temperature</u> <u>(*C)</u>	<u>Time</u> <u>(days)</u>	<u>Temperature</u> <u>(*C)</u>	<u>Time</u> <u>(days)</u>	<u>Temperature</u> <u>(*C)</u>
.000	24.1	.840	23.0	1.680	23.0	2.520	23.0
.020	25.2	.860	23.0	1.700	23.0	2.540	23.0
.040	25.5	.880	23.0	1.720	23.0	2.560	23.0
.060	25.9	.900	23.0	1.740	23.0	2.580	23.0
.080	25.9	.920	22.7	1.760	23.0	2.600	23.0
.100	26.2	.940	23.0	1.780	22.7	2.620	22.7
.120	26.2	.960	22.7	1.800	22.7	2.640	23.0
.140	26.2	.980	24.1	1.820	22.7	2.660	22.7
.160	26.6	1.000	24.5	1.840	22.7	2.680	23.0
.180	26.6	1.020	24.8	1.860	22.7	2.700	22.7
.200	26.6	1.040	25.5	1.880	22.7	2.720	22.7
.220	26.6	1.060	25.5	1.900	22.7	2.740	22.7
.240	26.6	1.080	25.9	1.920	22.7	2.760	22.7
.260	25.5	1.100	25.9	1.940	22.7	2.780	22.7
.280	24.5	1.120	26.2	1.960	22.3	2.800	22.3
.300	23.7	1.140	26.2	1.980	23.7	2.820	22.3
.320	23.4	1.160	26.2	2.000	24.1	2.840	22.3
.340	23.0	1.180	26.6	2.020	24.8	2.860	22.3
.360	23.0	1.200	26.6	2.040	25.2	2.880	22.3
.380	22.7	1.220	26.6	2.060	25.2	2.900	22.3
.400	22.7	1.240	25.5	2.080	25.5	2.920	22.0
.420	23.0	1.260	24.8	2.100	25.9	2.940	22.0
.440	23.0	1.280	24.1	2.120	25.9	2.960	22.0
.460	23.0	1.300	23.7	2.140	26.2	2.980	23.4
.480	23.0	1.320	23.7	2.160	26.2	3.000	23.7
.500	23.0	1.340	23.4	2.180	26.2	3.020	24.1
.520	23.0	1.360	23.4	2.200	26.6	3.040	24.5
.540	22.7	1.380	23.0	2.220	26.6	3.060	24.8
.560	23.0	1.400	23.4	2.240	25.5	3.080	24.8
.580	22.7	1.420	23.0	2.260	24.5	3.100	25.2
.600	23.0	1.440	23.0	2.280	24.1	3.120	25.2
.620	22.7	1.460	23.0	2.300	23.4	3.140	25.5
.640	23.0	1.480	23.0	2.320	23.4	3.160	25.5
.660	22.7	1.500	23.0	2.340	23.0	3.180	25.5
.680	22.7	1.520	23.0	2.360	23.0	3.200	24.5
.700	23.0	1.540	23.0	2.380	23.0	3.220	23.7
.720	23.0	1.560	23.0	2.400	23.0	3.240	23.0
.740	23.0	1.580	23.0	2.420	23.0	3.260	23.0
.760	23.0	1.600	23.0	2.440	23.0	3.280	22.7
.780	23.0	1.620	23.0	2.460	23.4	3.300	22.3
.800	23.4	1.640	23.0	2.480	23.0	3.320	22.0
.820	23.0	1.660	23.0	2.500	23.4	3.340	22.0

Time (days)	Temperature (*C)	Time (days)	Temperature (*C)	Time (days)	Temperature (*C)
3.360	22.0	4.280	22.7	5.200	26.6
3.380	22.0	4.300	22.3	5.220	25.5
3.400	22.0	4.320	22.3	5.240	24.5
3.420	22.0	4.340	22.3	5.260	23.7
3.440	22.0	4.360	22.0	5.280	23.4
3.460	22.0	4.380	22.0	5.300	23.0
3.480	22.0	4.400	22.0	5.320	23.0
3.500	22.0	4.420	22.0	5.340	23.0
3.520	22.0	4.440	22.3	5.360	22.7
3.540	22.0	4.460	22.3	5.380	23.0
3.560	22.0	4.480	22.3	5.400	23.0
3.580	22.0	4.500	22.3	5.420	23.0
3.600	22.0	4.520	22.3	5.440	23.0
3.620	22.0	4.540	22.3	5.460	23.0
3.640	22.3	4.560	22.3	5.480	23.0
3.660	22.3	4.580	22.7	5.500	23.7
3.680	22.0	4.600	22.7	5.520	23.4
3.700	22.3	4.620	22.7	5.540	23.4
3.720	22.0	4.640	22.3	5.560	23.4
3.740	22.0	4.660	22.7	5.580	23.4
3.760	22.0	4.680	22.7	5.600	23.4
3.780	22.0	4.700	22.3	5.620	23.0
3.800	22.0	4.720	22.3	5.640	23.0
3.820	22.0	4.740	22.7	5.660	22.7
3.840	22.0	4.760	22.7	5.680	22.7
3.860	22.0	4.780	22.7	5.700	22.7
3.880	22.0	4.800	22.7	5.720	22.7
3.900	22.0	4.820	22.7	5.740	22.7
3.920	22.0	4.840	22.7	5.760	22.7
3.940	22.0	4.860	22.3	5.780	22.7
3.960	22.0	4.880	22.7	5.800	22.7
3.980	23.0	4.900	22.7	5.820	22.7
4.000	23.7	4.920	22.7	5.840	22.7
4.020	24.1	4.940	22.7	5.860	22.7
4.040	24.5	4.960	22.7	5.880	22.7
4.060	24.5	4.980	23.7	5.900	22.7
4.080	24.8	5.000	24.5	5.920	22.3
4.100	24.8	5.020	24.8	5.940	22.3
4.120	25.2	5.040	25.2	5.960	22.7
4.140	25.2	5.060	25.5	5.980	24.1
4.160	25.5	5.080	25.5		
4.180	25.5	5.100	25.9		
4.200	25.5	5.120	25.9		
4.220	24.5	5.140	26.2		
4.240	23.4	5.160	26.2		
4.260	22.7	5.180	26.2		

Mix 3 R-01-3.5B Air Temperature Profile

Temperature Logging		Started: 0400 on 6/6/96		Stopped: 0400 on 6/12/96			
Time (days)	Temperature (*C)	Time (days)	Temperature (*C)	Time (days)	Temperature (*C)	Time (days)	Temperature (*C)
.000	27.0	.840	22.0	1.680	20.6	2.520	19.5
.020	27.0	.860	23.0	1.700	20.6	2.540	19.5
.040	27.0	.880	23.7	1.720	20.6	2.560	19.5
.060	27.0	.900	24.1	1.740	20.2	2.580	19.5
.080	27.0	.920	24.8	1.760	20.2	2.600	19.5
.100	23.7	.940	25.2	1.780	20.2	2.620	19.5
.120	23.0	.960	25.2	1.800	19.9	2.640	19.5
.140	22.7	.980	25.5	1.820	19.9	2.660	19.5
.160	22.0	1.000	25.9	1.840	20.9	2.680	19.5
.180	21.6	1.020	25.9	1.860	21.6	2.700	19.5
.200	21.6	1.040	26.2	1.880	22.3	2.720	19.5
.220	21.3	1.060	26.2	1.900	22.7	2.740	19.2
.240	21.3	1.080	26.2	1.920	23.0	2.760	19.2
.260	21.6	1.100	23.7	1.940	23.4	2.780	19.2
.280	21.6	1.120	23.0	1.960	23.7	2.800	19.2
.300	21.6	1.140	22.3	1.980	23.7	2.820	19.2
.320	21.6	1.160	22.0	2.000	24.1	2.840	19.9
.340	21.6	1.180	22.0	2.020	24.1	2.860	20.9
.360	21.6	1.200	21.6	2.040	24.5	2.880	21.6
.380	22.0	1.220	21.3	2.060	24.5	2.900	22.0
.400	22.0	1.240	21.3	2.080	24.8	2.920	22.3
.420	22.0	1.260	21.3	2.100	24.8	2.940	22.7
.440	22.0	1.280	21.6	2.120	22.3	2.960	22.7
.460	22.0	1.300	21.3	2.140	21.6	2.980	23.0
.480	22.3	1.320	21.3	2.160	20.9	3.000	23.4
.500	22.7	1.340	21.6	2.180	20.6	3.020	23.4
.520	22.3	1.360	21.6	2.200	20.2	3.040	23.4
.540	22.0	1.380	21.6	2.220	19.9	3.060	23.7
.560	22.0	1.400	21.6	2.240	19.5	3.080	23.7
.580	22.0	1.420	21.6	2.260	19.5	3.100	23.7
.600	21.6	1.440	21.3	2.280	19.5	3.120	21.3
.620	21.6	1.460	21.3	2.300	19.9	3.140	20.6
.640	21.6	1.480	21.3	2.320	19.9	3.160	20.6
.660	21.6	1.500	21.3	2.340	19.5	3.180	20.6
.680	21.3	1.520	21.3	2.360	19.5	3.200	20.2
.700	21.3	1.540	20.9	2.380	19.5	3.220	19.9
.720	21.3	1.560	20.9	2.400	19.5	3.240	19.9
.740	21.3	1.580	20.9	2.420	19.5	3.260	19.5
.760	21.3	1.600	20.9	2.440	19.5	3.280	19.5
.780	20.9	1.620	20.9	2.460	19.5	3.300	19.5
.800	20.9	1.640	20.9	2.480	19.5	3.320	19.5
.820	20.9	1.660	20.9	2.500	19.5	3.340	19.5

Time (days)	Temperature (*C)
3.360	19.5
3.380	19.5
3.400	19.5
3.420	19.5
3.440	19.5
3.460	19.5
3.480	19.5
3.500	19.5
3.520	19.5
3.540	19.5
3.560	19.2
3.580	19.2
3.600	19.2
3.620	19.2
3.640	19.2
3.660	19.2
3.680	19.2
3.700	19.2
3.720	19.2
3.740	19.2
3.760	19.2
3.780	18.8
3.800	18.8
3.820	18.8
3.840	19.9
3.860	20.6
3.880	21.3
3.900	21.6
3.920	22.0
3.940	22.3
3.960	22.7
3.980	22.7
4.000	23.0
4.020	23.0

Mix 3 R-01-3.5B Temperature Profile

Temperature Logging Started: 0400 on 6/6/96

Stopped: 0400 on 6/12/96

<u>Time</u> <u>(days)</u>	<u>Temperature</u> <u>(*C)</u>	<u>Time</u> <u>(days)</u>	<u>Temperature</u> <u>(*C)</u>	<u>Time</u> <u>(days)</u>	<u>Temperature</u> <u>(*C)</u>	<u>Time</u> <u>(days)</u>	<u>Temperature</u> <u>(*C)</u>
.000	26.9	.840	30.1	1.680	29.8	2.520	26.5
.020	27.2	.860	30.1	1.700	29.4	2.540	26.1
.040	27.6	.880	30.1	1.720	29.4	2.560	26.1
.060	27.9	.900	30.1	1.740	29.4	2.580	26.1
.080	28.3	.920	30.1	1.760	29.0	2.600	25.8
.100	28.7	.940	30.1	1.780	29.0	2.620	25.8
.120	29.4	.960	30.5	1.800	29.0	2.640	25.4
.140	29.4	.980	30.5	1.820	28.7	2.660	25.4
.160	29.8	1.000	30.9	1.840	28.7	2.680	25.1
.180	29.8	1.020	31.3	1.860	28.7	2.700	25.1
.200	29.8	1.040	31.3	1.880	28.7	2.720	24.7
.220	30.1	1.060	31.6	1.900	28.3	2.740	24.7
.240	30.1	1.080	31.6	1.920	28.7	2.760	24.0
.260	30.1	1.100	32.0	1.940	28.7	2.780	22.6
.280	30.1	1.120	32.0	1.960	28.7	2.800	-37.7
.300	30.1	1.140	32.4	1.980	28.7	2.820	-37.7
.320	30.1	1.160	32.4	2.000	28.7	2.840	-37.7
.340	30.1	1.180	32.0	2.020	29.0	2.860	-37.7
.360	30.1	1.200	32.0	2.040	29.0	2.880	-37.7
.380	30.1	1.220	32.0	2.060	29.0	2.900	-37.7
.400	30.1	1.240	32.0	2.080	29.4	2.920	-37.7
.420	30.1	1.260	31.6	2.100	29.4	2.940	-37.7
.440	30.1	1.280	31.6	2.120	29.4	2.960	-37.7
.460	30.1	1.300	31.6	2.140	29.4	2.980	-37.7
.480	30.1	1.320	31.3	2.160	29.4	3.000	-37.7
.500	30.1	1.340	31.3	2.180	29.4	3.020	-37.7
.520	30.1	1.360	31.3	2.200	29.4	3.040	-37.7
.540	30.1	1.380	30.9	2.220	29.0	3.060	-37.7
.560	30.1	1.400	30.9	2.240	29.0	3.080	-37.7
.580	30.1	1.420	30.9	2.260	28.7	3.100	-37.7
.600	30.1	1.440	30.9	2.280	28.7	3.120	-37.7
.620	30.1	1.460	30.5	2.300	28.3	3.140	-37.7
.640	30.1	1.480	30.5	2.320	28.3	3.160	-37.7
.660	30.1	1.500	30.5	2.340	27.9	3.180	-37.7
.680	30.1	1.520	30.5	2.360	27.9	3.200	-37.7
.700	30.1	1.540	30.5	2.380	27.6	3.220	-37.7
.720	30.1	1.560	30.1	2.400	27.6	3.240	-37.7
.740	30.1	1.580	30.1	2.420	27.2	3.260	-37.7
.760	30.1	1.600	30.1	2.440	27.2	3.280	-37.7
.780	30.1	1.620	30.1	2.460	26.9	3.300	-37.7
.800	30.1	1.640	29.8	2.480	26.9	3.320	-37.7
.820	30.1	1.660	29.8	2.500	26.5	3.340	-37.7

Time (days)	Temperature (*C)	Time (days)	Temperature (*C)	Time (days)	Temperature (*C)
3.360	-37.7	4.280	-37.7	5.200	-37.7
3.380	-37.7	4.300	-37.7	5.220	-37.7
3.400	-37.7	4.320	-37.7	5.240	-37.7
3.420	-37.7	4.340	-37.7	5.260	-37.7
3.440	-37.7	4.360	-37.7	5.280	-37.7
3.460	-37.7	4.380	-37.7	5.300	-37.7
3.480	-37.7	4.400	-37.7	5.320	-37.7
3.500	-37.7	4.420	-37.7	5.340	-37.7
3.520	-37.7	4.440	-37.7	5.360	-37.7
3.540	-37.7	4.460	-37.7	5.380	-37.7
3.560	-37.7	4.480	-37.7	5.400	-37.7
3.580	-37.7	4.500	-37.7	5.420	-37.7
3.600	-37.7	4.520	-37.7	5.440	-37.7
3.620	-37.7	4.540	-37.7	5.460	-37.7
3.640	-37.7	4.560	-37.7	5.480	-37.7
3.660	-37.7	4.580	-37.7	5.500	-37.7
3.680	-37.7	4.600	-37.7	5.520	-37.7
3.700	-37.7	4.620	-37.7	5.540	-37.7
3.720	-37.7	4.640	-37.7	5.560	-37.7
3.740	-37.7	4.660	-37.7	5.580	-37.7
3.760	-37.7	4.680	-37.7	5.600	-37.7
3.780	-37.7	4.700	-37.7	5.620	-37.7
3.800	-37.7	4.720	-37.7	5.640	-37.7
3.820	-37.7	4.740	-37.7	5.660	-37.7
3.840	-37.7	4.760	-37.7	5.680	-37.7
3.860	-37.7	4.780	-37.7	5.700	-37.7
3.880	-37.7	4.800	-37.7	5.720	-37.7
3.900	-37.7	4.820	-37.7	5.740	-37.7
3.920	-37.7	4.840	-37.7	5.760	-37.7
3.940	-37.7	4.860	-37.7	5.780	-37.7
3.960	-37.7	4.880	-37.7	5.800	-37.7
3.980	-37.7	4.900	-37.7	5.820	-37.7
4.000	-37.7	4.920	-37.7	5.840	-37.7
4.020	-37.7	4.940	-37.7	5.860	-37.7
4.040	-37.7	4.960	-37.7	5.880	-37.7
4.060	-37.7	4.980	-37.7	5.900	-37.7
4.080	-37.7	5.000	-37.7	5.920	-37.7
4.100	-37.7	5.020	-37.7	5.940	-37.7
4.120	-37.7	5.040	-37.7	5.960	-37.7
4.140	-37.7	5.060	-37.7	5.980	-37.7
4.160	-37.7	5.080	-37.7		
4.180	-37.7	5.100	-37.7		
4.200	-37.7	5.120	-37.7		
4.220	-37.7	5.140	-37.7		
4.240	-37.7	5.160	-37.7		
4.260	-37.7	5.180	-37.7		

Mix 3 R-01-6.5B Temperature Profile

Temperature Logging Started: 0400 on 6/6/96

Stopped: 0400 on 6/12/96

<u>Time</u> <u>(days)</u>	<u>Temperature</u> <u>(*C)</u>	<u>Time</u> <u>(days)</u>	<u>Temperature</u> <u>(*C)</u>	<u>Time</u> <u>(days)</u>	<u>Temperature</u> <u>(*C)</u>	<u>Time</u> <u>(days)</u>	<u>Temperature</u> <u>(*C)</u>
.000	27.2	.840	32.7	1.680	33.1	2.520	29.7
.020	28.2	.860	32.7	1.700	32.7	2.540	29.7
.040	28.6	.880	32.7	1.720	32.7	2.560	29.7
.060	29.0	.900	33.1	1.740	32.7	2.580	29.7
.080	29.3	.920	33.1	1.760	32.7	2.600	29.3
.100	29.7	.940	33.1	1.780	32.3	2.620	29.3
.120	29.7	.960	33.1	1.800	32.3	2.640	29.3
.140	30.1	.980	33.1	1.820	32.3	2.660	29.0
.160	30.4	1.000	33.4	1.840	31.9	2.680	29.0
.180	30.4	1.020	33.4	1.860	31.9	2.700	29.0
.200	30.8	1.040	33.4	1.880	31.9	2.720	29.0
.220	30.8	1.060	33.8	1.900	31.5	2.740	28.6
.240	30.8	1.080	33.8	1.920	31.5	2.760	28.6
.260	31.2	1.100	34.2	1.940	31.5	2.780	28.6
.280	31.2	1.120	34.2	1.960	31.5	2.800	28.6
.300	31.2	1.140	34.2	1.980	31.5	2.820	28.2
.320	31.2	1.160	34.6	2.000	31.5	2.840	28.2
.340	31.2	1.180	34.6	2.020	31.5	2.860	28.2
.360	31.5	1.200	34.6	2.040	31.5	2.880	28.2
.380	31.5	1.220	34.6	2.060	31.5	2.900	27.9
.400	31.5	1.240	34.6	2.080	31.5	2.920	27.9
.420	31.5	1.260	34.6	2.100	31.5	2.940	27.9
.440	31.5	1.280	34.2	2.120	31.5	2.960	27.9
.460	31.9	1.300	34.2	2.140	31.9	2.980	27.9
.480	31.9	1.320	34.2	2.160	31.9	3.000	27.9
.500	31.9	1.340	34.2	2.180	31.9	3.020	27.9
.520	31.9	1.360	34.2	2.200	31.9	3.040	27.9
.540	31.9	1.380	34.2	2.220	31.5	3.060	28.2
.560	32.3	1.400	33.8	2.240	31.5	3.080	28.2
.580	32.3	1.420	33.8	2.260	31.5	3.100	28.2
.600	32.3	1.440	33.8	2.280	31.2	3.120	28.2
.620	32.3	1.460	33.8	2.300	31.2	3.140	28.2
.640	32.3	1.480	33.8	2.320	31.2	3.160	28.6
.660	32.3	1.500	33.8	2.340	30.8	3.180	28.6
.680	32.7	1.520	33.4	2.360	30.8	3.200	28.6
.700	32.7	1.540	33.4	2.380	30.4	3.220	28.2
.720	32.7	1.560	33.4	2.400	30.4	3.240	28.2
.740	32.7	1.580	33.4	2.420	30.4	3.260	28.2
.760	32.7	1.600	33.4	2.440	30.1	3.280	28.2
.780	32.7	1.620	33.1	2.460	30.1	3.300	28.2
.800	32.7	1.640	33.1	2.480	30.1	3.320	28.2
.820	32.7	1.660	33.1	2.500	30.1	3.340	27.9

Time (days)	Temperature (*C)	Time (days)	Temperature (*C)	Time (days)	Temperature (*C)
3.360	27.9	4.280	26.1	5.200	26.8
3.380	27.9	4.300	26.1	5.220	26.8
3.400	27.9	4.320	26.1	5.240	26.8
3.420	27.5	4.340	26.1	5.260	26.8
3.440	27.5	4.360	26.1	5.280	26.8
3.460	27.5	4.380	26.1	5.300	26.8
3.480	27.5	4.400	26.1	5.320	26.4
3.500	27.2	4.420	25.7	5.340	26.4
3.520	27.2	4.440	25.7	5.360	26.4
3.540	27.2	4.460	25.7	5.380	26.4
3.560	27.2	4.480	25.7	5.400	26.4
3.580	27.2	4.500	25.7	5.420	26.4
3.600	26.8	4.520	25.7	5.440	26.4
3.620	26.8	4.540	25.7	5.460	26.4
3.640	26.8	4.560	25.7	5.480	26.4
3.660	26.8	4.580	25.7	5.500	26.4
3.680	26.8	4.600	25.7	5.520	26.4
3.700	26.4	4.620	25.7	5.540	26.4
3.720	26.4	4.640	25.7	5.560	26.4
3.740	26.4	4.660	25.7	5.580	26.4
3.760	26.4	4.680	25.7	5.600	26.4
3.780	26.4	4.700	25.7	5.620	26.4
3.800	26.1	4.720	25.7	5.640	26.4
3.820	26.1	4.740	25.7	5.660	26.4
3.840	26.1	4.760	25.7	5.680	26.4
3.860	26.1	4.780	25.7	5.700	26.4
3.880	26.1	4.800	25.7	5.720	26.4
3.900	25.7	4.820	25.7	5.740	26.4
3.920	25.7	4.840	25.7	5.760	26.4
3.940	25.7	4.860	25.7	5.780	26.4
3.960	25.7	4.880	25.4	5.800	26.4
3.980	25.7	4.900	25.4	5.820	26.4
4.000	26.1	4.920	25.4	5.840	26.4
4.020	26.1	4.940	25.7	5.860	26.4
4.040	26.1	4.960	25.7	5.880	26.4
4.060	26.1	4.980	25.7	5.900	26.4
4.080	26.4	5.000	25.7	5.920	26.4
4.100	26.4	5.020	25.7	5.940	26.4
4.120	26.4	5.040	26.1	5.960	26.4
4.140	26.4	5.060	26.1	5.980	26.8
4.160	26.4	5.080	26.1		
4.180	26.4	5.100	26.4		
4.200	26.4	5.120	26.4		
4.220	26.4	5.140	26.4		
4.240	26.4	5.160	26.4		
4.260	26.4	5.180	26.8		

Mix 3 R-01-8.5B Temperature Profile

Temperature Logging Started: 0400 on 6/6/96

Stopped: 0400 on 6/12/96

<u>Time</u> <u>(days)</u>	<u>Temperature</u> <u>(*C)</u>	<u>Time</u> <u>(days)</u>	<u>Temperature</u> <u>(*C)</u>	<u>Time</u> <u>(days)</u>	<u>Temperature</u> <u>(*C)</u>	<u>Time</u> <u>(days)</u>	<u>Temperature</u> <u>(*C)</u>
.000	26.6	.840	22.0	1.680	20.6	2.520	18.5
.020	28.4	.860	22.0	1.700	20.6	2.540	18.5
.040	28.4	.880	22.0	1.720	20.6	2.560	18.5
.060	28.4	.900	22.0	1.740	20.6	2.580	18.5
.080	28.4	.920	21.6	1.760	20.6	2.600	18.5
.100	28.0	.940	21.6	1.780	20.2	2.620	18.5
.120	27.7	.960	21.6	1.800	20.2	2.640	18.1
.140	27.7	.980	21.6	1.820	20.2	2.660	18.1
.160	27.3	1.000	21.6	1.840	19.9	2.680	18.1
.180	27.0	1.020	21.6	1.860	19.9	2.700	18.1
.200	27.0	1.040	21.6	1.880	19.9	2.720	18.1
.220	26.6	1.060	21.6	1.900	19.9	2.740	18.1
.240	26.2	1.080	21.6	1.920	19.5	2.760	18.1
.260	26.2	1.100	21.6	1.940	19.5	2.780	18.1
.280	25.9	1.120	21.6	1.960	19.5	2.800	17.8
.300	25.5	1.140	22.0	1.980	19.5	2.820	17.8
.320	25.2	1.160	22.0	2.000	19.5	2.840	17.8
.340	25.2	1.180	22.0	2.020	19.5	2.860	17.8
.360	24.8	1.200	22.0	2.040	19.2	2.880	17.8
.380	24.5	1.220	22.0	2.060	19.5	2.900	17.8
.400	24.5	1.240	22.0	2.080	19.5	2.920	17.8
.420	24.1	1.260	22.0	2.100	19.5	2.940	17.4
.440	24.1	1.280	21.6	2.120	19.5	2.960	17.4
.460	23.7	1.300	21.6	2.140	19.5	2.980	17.4
.480	23.7	1.320	21.6	2.160	19.5	3.000	17.4
.500	23.7	1.340	21.6	2.180	19.5	3.020	17.4
.520	23.4	1.360	21.6	2.200	19.5	3.040	17.4
.540	23.4	1.380	21.3	2.220	19.5	3.060	17.4
.560	23.4	1.400	21.3	2.240	19.5	3.080	17.8
.580	23.0	1.420	21.3	2.260	19.5	3.100	17.8
.600	23.0	1.440	21.3	2.280	19.5	3.120	17.8
.620	23.0	1.460	21.3	2.300	19.2	3.140	17.8
.640	23.0	1.480	21.3	2.320	19.2	3.160	17.8
.660	23.0	1.500	21.3	2.340	19.2	3.180	17.8
.680	22.7	1.520	21.3	2.360	19.2	3.200	17.8
.700	22.7	1.540	20.9	2.380	18.8	3.220	17.8
.720	22.7	1.560	20.9	2.400	18.8	3.240	17.8
.740	22.7	1.580	20.9	2.420	18.8	3.260	17.8
.760	22.3	1.600	20.9	2.440	18.8	3.280	17.8
.780	22.3	1.620	20.9	2.460	18.8	3.300	17.8
.800	22.3	1.640	20.9	2.480	18.5	3.320	17.8
.820	22.3	1.660	20.9	2.500	18.5	3.340	17.8

Time (days)	Temperature (*C)	Time (days)	Temperature (*C)	Time (days)	Temperature (*C)
3.360	17.8	4.280	16.7	5.200	17.1
3.380	17.4	4.300	16.7	5.220	17.1
3.400	17.4	4.320	16.7	5.240	17.1
3.420	17.4	4.340	16.7	5.260	17.1
3.440	17.4	4.360	16.7	5.280	17.1
3.460	17.4	4.380	16.7	5.300	17.1
3.480	17.4	4.400	16.7	5.320	17.1
3.500	17.4	4.420	16.7	5.340	17.1
3.520	17.4	4.440	16.7	5.360	17.1
3.540	17.4	4.460	16.7	5.380	17.1
3.560	17.4	4.480	16.7	5.400	17.1
3.580	17.4	4.500	16.7	5.420	17.1
3.600	17.4	4.520	16.7	5.440	17.1
3.620	17.4	4.540	16.7	5.460	17.1
3.640	17.4	4.560	17.1	5.480	17.4
3.660	17.4	4.580	17.1	5.500	17.4
3.680	17.1	4.600	17.1	5.520	17.4
3.700	17.1	4.620	17.1	5.540	17.4
3.720	17.1	4.640	17.1	5.560	17.4
3.740	17.1	4.660	17.1	5.580	17.4
3.760	17.1	4.680	17.1	5.600	17.4
3.780	17.1	4.700	17.1	5.620	17.4
3.800	17.1	4.720	17.1	5.640	17.8
3.820	17.1	4.740	17.1	5.660	17.8
3.840	17.1	4.760	17.1	5.680	17.8
3.860	17.1	4.780	17.1	5.700	17.8
3.880	16.7	4.800	17.1	5.720	17.8
3.900	16.7	4.820	17.1	5.740	17.8
3.920	16.7	4.840	17.1	5.760	17.8
3.940	16.7	4.860	17.1	5.780	17.8
3.960	16.7	4.880	17.1	5.800	17.4
3.980	16.7	4.900	17.1	5.820	17.4
4.000	16.7	4.920	16.7	5.840	17.4
4.020	16.7	4.940	16.7	5.860	17.4
4.040	16.7	4.960	16.7	5.880	17.4
4.060	16.7	4.980	16.7	5.900	17.4
4.080	16.7	5.000	16.7	5.920	17.4
4.100	16.7	5.020	16.7	5.940	17.4
4.120	16.7	5.040	16.7	5.960	17.4
4.140	17.1	5.060	17.1	5.980	17.4
4.160	17.1	5.080	17.1		
4.180	17.1	5.100	17.1		
4.200	17.1	5.120	17.1		
4.220	16.7	5.140	17.1		
4.240	16.7	5.160	17.1		
4.260	16.7	5.180	17.1		

Mix 3 R-04-12 Temperature Profile

Temperature Logging Started: 0400 on 6/6/96

Stopped: 0400 on 6/12/96

<u>Time</u> <u>(days)</u>	<u>Temperature</u> <u>(*C)</u>	<u>Time</u> <u>(days)</u>	<u>Temperature</u> <u>(*C)</u>	<u>Time</u> <u>(days)</u>	<u>Temperature</u> <u>(*C)</u>	<u>Time</u> <u>(days)</u>	<u>Temperature</u> <u>(*C)</u>
.000	27.1	.840	54.0	1.680	57.4	2.520	49.3
.020	32.7	.860	54.6	1.700	56.8	2.540	48.8
.040	33.4	.880	54.6	1.720	56.8	2.560	48.8
.060	34.2	.900	55.1	1.740	56.8	2.580	48.3
.080	35.0	.920	55.1	1.760	56.8	2.600	48.3
.100	35.7	.940	55.7	1.780	56.8	2.620	47.8
.120	36.5	.960	55.7	1.800	56.3	2.640	47.8
.140	36.9	.980	56.3	1.820	56.3	2.660	47.4
.160	37.7	1.000	56.3	1.840	56.3	2.680	47.4
.180	38.1	1.020	56.3	1.860	56.3	2.700	46.9
.200	39.0	1.040	56.3	1.880	56.3	2.720	46.9
.220	39.4	1.060	56.8	1.900	55.7	2.740	46.4
.240	40.2	1.080	56.8	1.920	55.7	2.760	46.4
.260	40.6	1.100	56.8	1.940	55.7	2.780	46.0
.280	41.5	1.120	57.4	1.960	55.1	2.800	45.5
.300	41.9	1.140	57.4	1.980	55.1	2.820	45.5
.320	42.8	1.160	57.4	2.000	55.1	2.840	45.0
.340	43.2	1.180	57.4	2.020	55.1	2.860	45.0
.360	43.7	1.200	57.4	2.040	54.6	2.880	44.6
.380	44.6	1.220	58.0	2.060	54.6	2.900	44.6
.400	45.0	1.240	58.0	2.080	54.6	2.920	44.1
.420	46.0	1.260	58.0	2.100	54.0	2.940	44.1
.440	46.4	1.280	58.0	2.120	54.0	2.960	43.7
.460	46.9	1.300	58.0	2.140	54.0	2.980	43.7
.480	47.4	1.320	58.0	2.160	54.0	3.000	43.2
.500	47.8	1.340	58.0	2.180	53.5	3.020	43.2
.520	48.3	1.360	58.0	2.200	53.5	3.040	42.8
.540	48.3	1.380	57.4	2.220	53.5	3.060	42.8
.560	48.8	1.400	57.4	2.240	52.9	3.080	42.8
.580	49.3	1.420	57.4	2.260	52.9	3.100	42.4
.600	49.8	1.440	57.4	2.280	52.4	3.120	42.4
.620	50.3	1.460	57.4	2.300	52.4	3.140	42.4
.640	50.8	1.480	57.4	2.320	51.9	3.160	41.9
.660	50.8	1.500	57.4	2.340	51.9	3.180	41.9
.680	51.3	1.520	57.4	2.360	51.3	3.200	41.5
.700	51.9	1.540	57.4	2.380	51.3	3.220	41.5
.720	52.4	1.560	57.4	2.400	50.8	3.240	41.1
.740	52.4	1.580	57.4	2.420	50.8	3.260	41.1
.760	52.9	1.600	57.4	2.440	50.3	3.280	40.6
.780	53.5	1.620	57.4	2.460	50.3	3.300	40.6
.800	53.5	1.640	57.4	2.480	49.8	3.320	40.6
.820	54.0	1.660	57.4	2.500	49.8	3.340	40.2

Time (days)	Temperature (*C)	Time (days)	Temperature (*C)	Time (days)	Temperature (*C)
3.360	39.8	4.280	32.7	5.200	29.3
3.380	39.8	4.300	32.7	5.220	29.3
3.400	39.8	4.320	32.3	5.240	29.3
3.420	39.4	4.340	32.3	5.260	29.3
3.440	39.0	4.360	32.3	5.280	29.3
3.460	39.0	4.380	32.3	5.300	29.3
3.480	38.6	4.400	31.9	5.320	29.3
3.500	38.6	4.420	31.9	5.340	29.3
3.520	38.6	4.440	31.9	5.360	28.9
3.540	38.1	4.460	31.5	5.380	28.9
3.560	38.1	4.480	31.5	5.400	28.9
3.580	37.7	4.500	31.5	5.420	28.9
3.600	37.7	4.520	31.5	5.440	28.9
3.620	37.3	4.540	31.2	5.460	28.9
3.640	37.3	4.560	31.2	5.480	28.9
3.660	36.9	4.580	31.2	5.500	28.9
3.680	36.9	4.600	31.2	5.520	28.9
3.700	36.5	4.620	30.8	5.540	28.9
3.720	36.5	4.640	30.8	5.560	28.9
3.740	36.1	4.660	30.8	5.580	28.9
3.760	36.1	4.680	30.8	5.600	28.9
3.780	36.1	4.700	30.8	5.620	28.6
3.800	35.7	4.720	30.4	5.640	28.6
3.820	35.7	4.740	30.4	5.660	28.6
3.840	35.4	4.760	30.4	5.680	28.6
3.860	35.4	4.780	30.4	5.700	28.6
3.880	35.0	4.800	30.4	5.720	28.6
3.900	35.0	4.820	30.0	5.740	28.6
3.920	34.6	4.840	30.0	5.760	28.6
3.940	34.6	4.860	30.0	5.780	28.6
3.960	34.6	4.880	30.0	5.800	28.6
3.980	34.2	4.900	29.7	5.820	28.6
4.000	34.2	4.920	29.7	5.840	28.6
4.020	34.2	4.940	29.7	5.860	28.6
4.040	34.2	4.960	29.7	5.880	28.6
4.060	33.8	4.980	29.7	5.900	28.6
4.080	33.8	5.000	29.7	5.920	28.6
4.100	33.8	5.020	29.7	5.940	28.6
4.120	33.4	5.040	29.7	5.960	28.6
4.140	33.4	5.060	29.7	5.980	28.6
4.160	33.4	5.080	29.7		
4.180	33.4	5.100	29.7		
4.200	33.0	5.120	29.7		
4.220	33.0	5.140	29.7		
4.240	33.0	5.160	29.3		
4.260	32.7	5.180	29.7		

Mix 3 R-07-12 Temperature Profile

Temperature Logging Started: 0400 on 6/6/96

Stopped: 0400 on 6/12/96

<u>Time</u> <u>(days)</u>	<u>Temperature</u> <u>(*C)</u>	<u>Time</u> <u>(days)</u>	<u>Temperature</u> <u>(*C)</u>	<u>Time</u> <u>(days)</u>	<u>Temperature</u> <u>(*C)</u>	<u>Time</u> <u>(days)</u>	<u>Temperature</u> <u>(*C)</u>
.000	29.9	.840	59.6	1.680	62.1	2.520	51.6
.020	31.0	.860	60.2	1.700	61.5	2.540	51.1
.040	32.1	.880	60.8	1.720	61.5	2.560	50.6
.060	32.9	.900	61.5	1.740	61.5	2.580	50.6
.080	34.0	.920	61.5	1.760	61.5	2.600	50.1
.100	35.2	.940	62.1	1.780	61.5	2.620	49.6
.120	36.0	.960	62.8	1.800	62.1	2.640	49.6
.140	37.1	.980	62.8	1.820	62.1	2.660	49.1
.160	38.0	1.000	62.8	1.840	61.5	2.680	49.1
.180	39.2	1.020	63.5	1.860	60.8	2.700	49.1
.200	40.0	1.040	63.5	1.880	60.2	2.720	49.1
.220	40.9	1.060	64.2	1.900	58.9	2.740	49.1
.240	41.7	1.080	64.2	1.920	58.3	2.760	49.1
.260	42.6	1.100	64.9	1.940	58.3	2.780	49.1
.280	43.0	1.120	64.9	1.960	58.3	2.800	49.1
.300	43.9	1.140	65.6	1.980	58.3	2.820	49.1
.320	44.4	1.160	65.6	2.000	58.3	2.840	48.6
.340	45.3	1.180	65.6	2.020	58.3	2.860	48.6
.360	45.7	1.200	66.3	2.040	58.3	2.880	48.6
.380	46.2	1.220	66.3	2.060	57.7	2.900	48.1
.400	46.7	1.240	66.3	2.080	58.3	2.920	48.1
.420	47.1	1.260	66.3	2.100	57.7	2.940	48.1
.440	48.1	1.280	66.3	2.120	57.1	2.960	48.1
.460	48.1	1.300	65.6	2.140	56.5	2.980	47.6
.480	49.1	1.320	65.6	2.160	55.4	3.000	47.6
.500	49.6	1.340	65.6	2.180	54.8	3.020	47.6
.520	49.6	1.360	65.6	2.200	54.8	3.040	47.6
.540	50.1	1.380	64.9	2.220	54.8	3.060	47.6
.560	50.6	1.400	64.9	2.240	55.4	3.080	47.1
.580	51.6	1.420	64.9	2.260	55.4	3.100	47.1
.600	51.6	1.440	64.2	2.280	55.4	3.120	47.1
.620	51.1	1.460	64.2	2.300	54.8	3.140	47.1
.640	51.1	1.480	64.2	2.320	54.8	3.160	47.1
.660	50.6	1.500	64.2	2.340	54.3	3.180	46.7
.680	51.6	1.520	63.5	2.360	54.3	3.200	46.7
.700	53.2	1.540	63.5	2.380	53.7	3.220	46.7
.720	54.8	1.560	63.5	2.400	53.7	3.240	46.7
.740	56.0	1.580	62.8	2.420	53.2	3.260	46.7
.760	57.1	1.600	62.8	2.440	52.7	3.280	46.2
.780	57.7	1.620	62.8	2.460	52.7	3.300	46.2
.800	58.3	1.640	62.1	2.480	52.1	3.320	46.2
.820	58.9	1.660	62.1	2.500	51.6	3.340	45.7

Time (days)	Temperature (*C)	Time (days)	Temperature (*C)	Time (days)	Temperature (*C)
3.360	45.7	4.280	39.6	5.200	35.6
3.380	45.7	4.300	39.2	5.220	35.6
3.400	45.3	4.320	38.8	5.240	35.6
3.420	45.3	4.340	38.8	5.260	35.6
3.440	45.3	4.360	38.8	5.280	35.6
3.460	44.8	4.380	38.8	5.300	35.6
3.480	44.8	4.400	38.4	5.320	35.6
3.500	44.8	4.420	38.4	5.340	35.6
3.520	44.4	4.440	38.4	5.360	35.2
3.540	44.4	4.460	38.4	5.380	35.2
3.560	44.4	4.480	38.4	5.400	35.2
3.580	43.9	4.500	38.4	5.420	35.2
3.600	43.9	4.520	38.0	5.440	35.2
3.620	43.9	4.540	38.0	5.460	35.2
3.640	43.9	4.560	38.0	5.480	35.2
3.660	43.5	4.580	38.0	5.500	34.8
3.680	43.5	4.600	37.5	5.520	34.8
3.700	43.5	4.620	37.5	5.540	34.8
3.720	43.5	4.640	37.5	5.560	34.8
3.740	43.0	4.660	37.5	5.580	34.8
3.760	43.0	4.680	37.5	5.600	34.8
3.780	43.0	4.700	37.1	5.620	34.8
3.800	43.0	4.720	37.1	5.640	34.8
3.820	42.6	4.740	37.1	5.660	34.8
3.840	42.6	4.760	37.1	5.680	34.8
3.860	42.6	4.780	37.1	5.700	34.4
3.880	42.6	4.800	36.7	5.720	34.4
3.900	42.1	4.820	36.7	5.740	34.4
3.920	42.1	4.840	36.7	5.760	34.4
3.940	42.1	4.860	36.7	5.780	34.4
3.960	42.1	4.880	36.7	5.800	34.4
3.980	42.1	4.900	36.4	5.820	34.4
4.000	41.7	4.920	36.4	5.840	34.4
4.020	41.7	4.940	36.4	5.860	34.4
4.040	41.7	4.960	36.4	5.880	34.4
4.060	41.7	4.980	36.4	5.900	34.4
4.080	41.7	5.000	36.0	5.920	34.0
4.100	41.3	5.020	36.0	5.940	34.0
4.120	41.3	5.040	36.0	5.960	34.0
4.140	41.3	5.060	36.0	5.980	34.0
4.160	40.9	5.080	36.0		
4.180	40.9	5.100	36.0		
4.200	40.4	5.120	36.0		
4.220	40.4	5.140	36.0		
4.240	40.0	5.160	36.0		
4.260	39.6	5.180	35.6		

Mix 3 R-10-12 Temperature Profile

Temperature Logging Started: 0400 on 6/6/96

Stopped: 0400 on 6/12/96

Time (days)	Temperature (*C)	Time (days)	Temperature (*C)	Time (days)	Temperature (*C)	Time (days)	Temperature (*C)
.000	29.9	.840	72.7	1.680	68.6	2.520	57.7
.020	31.7	.860	72.7	1.700	67.8	2.540	57.7
.040	32.9	.880	72.7	1.720	67.8	2.560	57.1
.060	34.4	.900	72.7	1.740	67.8	2.580	56.5
.080	35.6	.920	72.7	1.760	67.1	2.600	56.5
.100	36.7	.940	72.7	1.780	67.1	2.620	56.0
.120	38.0	.960	72.7	1.800	67.1	2.640	56.0
.140	39.2	.980	72.7	1.820	67.1	2.660	56.0
.160	40.4	1.000	72.7	1.840	66.3	2.680	55.4
.180	42.1	1.020	72.7	1.860	66.3	2.700	54.8
.200	43.5	1.040	72.7	1.880	66.3	2.720	54.8
.220	44.8	1.060	72.7	1.900	66.3	2.740	54.3
.240	46.2	1.080	72.7	1.920	65.6	2.760	53.7
.260	47.6	1.100	72.7	1.940	65.6	2.780	53.7
.280	48.6	1.120	72.7	1.960	65.6	2.800	53.2
.300	49.6	1.140	72.7	1.980	64.9	2.820	53.2
.320	51.1	1.160	72.7	2.000	64.9	2.840	52.7
.340	52.1	1.180	72.7	2.020	64.9	2.860	52.7
.360	53.2	1.200	72.7	2.040	64.2	2.880	52.1
.380	54.3	1.220	72.7	2.060	64.2	2.900	52.1
.400	55.4	1.240	71.9	2.080	64.2	2.920	51.6
.420	56.0	1.260	71.9	2.100	64.2	2.940	51.6
.440	57.1	1.280	71.9	2.120	63.5	2.960	51.1
.460	58.3	1.300	71.9	2.140	63.5	2.980	51.1
.480	59.6	1.320	71.9	2.160	63.5	3.000	51.1
.500	60.8	1.340	71.0	2.180	62.8	3.020	50.6
.520	61.5	1.360	71.0	2.200	62.8	3.040	50.6
.540	62.8	1.380	71.0	2.220	62.1	3.060	50.6
.560	64.2	1.400	71.0	2.240	62.1	3.080	50.1
.580	64.9	1.420	70.2	2.260	62.1	3.100	50.1
.600	66.3	1.440	70.2	2.280	61.5	3.120	50.1
.620	67.1	1.460	70.2	2.300	61.5	3.140	49.6
.640	67.8	1.480	70.2	2.320	60.8	3.160	49.6
.660	68.6	1.500	70.2	2.340	60.8	3.180	49.6
.680	69.4	1.520	69.4	2.360	60.2	3.200	49.1
.700	70.2	1.540	69.4	2.380	60.2	3.220	49.1
.720	71.0	1.560	69.4	2.400	59.6	3.240	49.1
.740	71.0	1.580	69.4	2.420	59.6	3.260	48.6
.760	71.9	1.600	69.4	2.440	58.9	3.280	48.6
.780	71.9	1.620	68.6	2.460	58.9	3.300	48.6
.800	71.9	1.640	68.6	2.480	58.3	3.320	48.1
.820	72.7	1.660	68.6	2.500	58.3	3.340	48.1

Time (days)	Temperature (*C)	Time (days)	Temperature (*C)	Time (days)	Temperature (*C)
3.360	48.1	4.280	40.9	5.200	36.4
3.380	47.6	4.300	40.9	5.220	36.4
3.400	47.6	4.320	40.9	5.240	36.4
3.420	47.6	4.340	40.9	5.260	36.4
3.440	47.6	4.360	40.9	5.280	36.4
3.460	47.1	4.380	40.4	5.300	36.4
3.480	47.1	4.400	40.4	5.320	36.4
3.500	47.1	4.420	40.4	5.340	36.0
3.520	46.7	4.440	40.4	5.360	36.0
3.540	46.7	4.460	40.0	5.380	36.0
3.560	46.2	4.480	40.0	5.400	36.0
3.580	46.2	4.500	40.0	5.420	36.0
3.600	45.7	4.520	39.6	5.440	35.6
3.620	45.7	4.540	39.6	5.460	36.0
3.640	45.7	4.560	39.6	5.480	35.6
3.660	45.3	4.580	39.2	5.500	35.6
3.680	45.3	4.600	39.2	5.520	35.6
3.700	45.3	4.620	39.2	5.540	35.6
3.720	44.8	4.640	38.8	5.560	35.6
3.740	44.8	4.660	38.8	5.580	35.6
3.760	44.4	4.680	38.8	5.600	35.6
3.780	44.4	4.700	38.8	5.620	35.2
3.800	43.9	4.720	38.4	5.640	35.2
3.820	43.9	4.740	38.4	5.660	35.2
3.840	43.9	4.760	38.4	5.680	35.2
3.860	43.5	4.780	38.4	5.700	35.2
3.880	43.5	4.800	38.0	5.720	35.2
3.900	43.5	4.820	38.0	5.740	35.2
3.920	43.0	4.840	38.0	5.760	34.8
3.940	43.0	4.860	38.0	5.780	34.8
3.960	43.0	4.880	37.5	5.800	34.8
3.980	42.6	4.900	37.5	5.820	34.8
4.000	42.6	4.920	37.5	5.840	34.8
4.020	42.6	4.940	37.5	5.860	34.4
4.040	42.6	4.960	37.1	5.880	34.4
4.060	42.6	4.980	37.1	5.900	34.4
4.080	42.1	5.000	37.1	5.920	34.4
4.100	42.1	5.020	37.1	5.940	34.4
4.120	42.1	5.040	37.1	5.960	34.4
4.140	42.1	5.060	36.7	5.980	34.4
4.160	41.7	5.080	36.7		
4.180	41.7	5.100	36.7		
4.200	41.7	5.120	36.7		
4.220	41.3	5.140	36.7		
4.240	41.3	5.160	36.7		
4.260	41.3	5.180	36.7		

Mix 3 R-10-12 Air Temperature Profile

Temperature Logging Started: 0400 on 6/6/96

Stopped: 0400 on 6/12/96

<u>Time</u> <u>(days)</u>	<u>Temperature</u> <u>(*C)</u>	<u>Time</u> <u>(days)</u>	<u>Temperature</u> <u>(*C)</u>	<u>Time</u> <u>(days)</u>	<u>Temperature</u> <u>(*C)</u>	<u>Time</u> <u>(days)</u>	<u>Temperature</u> <u>(*C)</u>
.000	27.0	.840	23.4	1.680	22.3	2.520	20.9
.020	26.6	.860	24.1	1.700	22.3	2.540	20.9
.040	26.6	.880	24.5	1.720	22.0	2.560	20.9
.060	26.6	.900	25.2	1.740	22.0	2.580	20.9
.080	26.6	.920	25.2	1.760	22.0	2.600	20.9
.100	24.8	.940	25.5	1.780	22.0	2.620	20.9
.120	24.1	.960	25.9	1.800	21.6	2.640	20.9
.140	23.7	.980	25.9	1.820	21.6	2.660	20.9
.160	23.0	1.000	26.2	1.840	22.3	2.680	20.9
.180	23.0	1.020	26.2	1.860	23.0	2.700	20.9
.200	23.0	1.040	26.2	1.880	23.7	2.720	20.9
.220	22.7	1.060	26.2	1.900	24.1	2.740	20.9
.240	22.7	1.080	26.6	1.920	24.1	2.760	20.9
.260	22.7	1.100	24.5	1.940	24.5	2.780	20.9
.280	22.7	1.120	23.7	1.960	24.5	2.800	20.9
.300	22.7	1.140	23.4	1.980	24.8	2.820	20.6
.320	22.7	1.160	23.0	2.000	24.8	2.840	21.3
.340	22.7	1.180	23.0	2.020	24.8	2.860	22.3
.360	22.7	1.200	22.7	2.040	25.2	2.880	22.7
.380	23.0	1.220	22.7	2.060	25.2	2.900	23.0
.400	23.0	1.240	22.7	2.080	25.2	2.920	23.4
.420	23.0	1.260	22.7	2.100	25.2	2.940	23.4
.440	23.0	1.280	22.7	2.120	23.4	2.960	23.7
.460	23.0	1.300	22.7	2.140	22.7	2.980	23.7
.480	23.0	1.320	22.7	2.160	22.3	3.000	24.1
.500	23.4	1.340	22.7	2.180	21.6	3.020	24.1
.520	23.4	1.360	22.7	2.200	21.6	3.040	24.1
.540	23.0	1.380	22.7	2.220	21.3	3.060	24.1
.560	23.0	1.400	22.7	2.240	21.3	3.080	24.1
.580	23.0	1.420	23.0	2.260	21.3	3.100	24.5
.600	23.0	1.440	22.7	2.280	21.3	3.120	22.3
.620	23.0	1.460	22.7	2.300	21.3	3.140	21.6
.640	22.7	1.480	22.7	2.320	20.9	3.160	22.0
.660	22.7	1.500	22.3	2.340	21.3	3.180	22.0
.680	22.7	1.520	22.7	2.360	21.3	3.200	21.6
.700	22.7	1.540	22.7	2.380	20.9	3.220	21.3
.720	22.7	1.560	22.3	2.400	21.3	3.240	21.3
.740	22.7	1.580	22.3	2.420	20.9	3.260	20.9
.760	22.7	1.600	22.3	2.440	20.9	3.280	20.9
.780	22.7	1.620	22.3	2.460	20.9	3.300	20.9
.800	22.7	1.640	22.3	2.480	20.9	3.320	20.9
.820	22.7	1.660	22.3	2.500	20.9	3.340	20.6

Time (days)	Temperature (*C)	Time (days)	Temperature (*C)	Time (days)	Temperature (*C)
3.360	20.9	4.280	20.9	5.200	22.3
3.380	20.9	4.300	20.9	5.220	22.0
3.400	20.9	4.320	20.9	5.240	21.6
3.420	20.9	4.340	20.9	5.260	21.6
3.440	20.6	4.360	20.9	5.280	22.0
3.460	20.9	4.380	20.9	5.300	22.0
3.480	20.6	4.400	20.9	5.320	22.0
3.500	20.6	4.420	20.9	5.340	22.0
3.520	20.6	4.440	20.9	5.360	22.0
3.540	20.6	4.460	20.9	5.380	22.0
3.560	20.6	4.480	21.3	5.400	22.0
3.580	20.6	4.500	21.3	5.420	22.0
3.600	20.6	4.520	21.3	5.440	22.0
3.620	20.6	4.540	20.9	5.460	22.0
3.640	20.6	4.560	21.3	5.480	22.0
3.660	20.9	4.580	21.3	5.500	22.7
3.680	20.6	4.600	21.3	5.520	22.3
3.700	20.6	4.620	21.3	5.540	22.3
3.720	20.6	4.640	21.3	5.560	22.3
3.740	20.6	4.660	20.9	5.580	22.0
3.760	20.6	4.680	20.9	5.600	22.0
3.780	20.6	4.700	20.9	5.620	22.0
3.800	20.6	4.720	20.9	5.640	21.6
3.820	20.6	4.740	20.9	5.660	21.6
3.840	21.3	4.760	20.9	5.680	21.6
3.860	22.0	4.780	20.6	5.700	22.0
3.880	22.3	4.800	20.6	5.720	22.0
3.900	22.7	4.820	20.6	5.740	22.0
3.920	23.0	4.840	21.3	5.760	21.6
3.940	23.0	4.860	22.3	5.780	21.6
3.960	23.4	4.880	22.7	5.800	21.6
3.980	23.4	4.900	23.0	5.820	22.0
4.000	23.7	4.920	23.4	5.840	22.7
4.020	23.7	4.940	23.7	5.860	23.7
4.040	23.7	4.960	23.7	5.880	24.1
4.060	23.7	4.980	24.1	5.900	24.5
4.080	22.0	5.000	24.1	5.920	24.8
4.100	21.3	5.020	24.1	5.940	25.2
4.120	21.3	5.040	24.5	5.960	25.2
4.140	22.0	5.060	24.5	5.980	25.5
4.160	22.0	5.080	24.5		
4.180	20.9	5.100	22.7		
4.200	20.6	5.120	22.0		
4.220	20.6	5.140	22.0		
4.240	20.6	5.160	22.0		
4.260	20.9	5.180	22.0		

APPENDIX E: COMPOST TEMPERATURE PROFILE

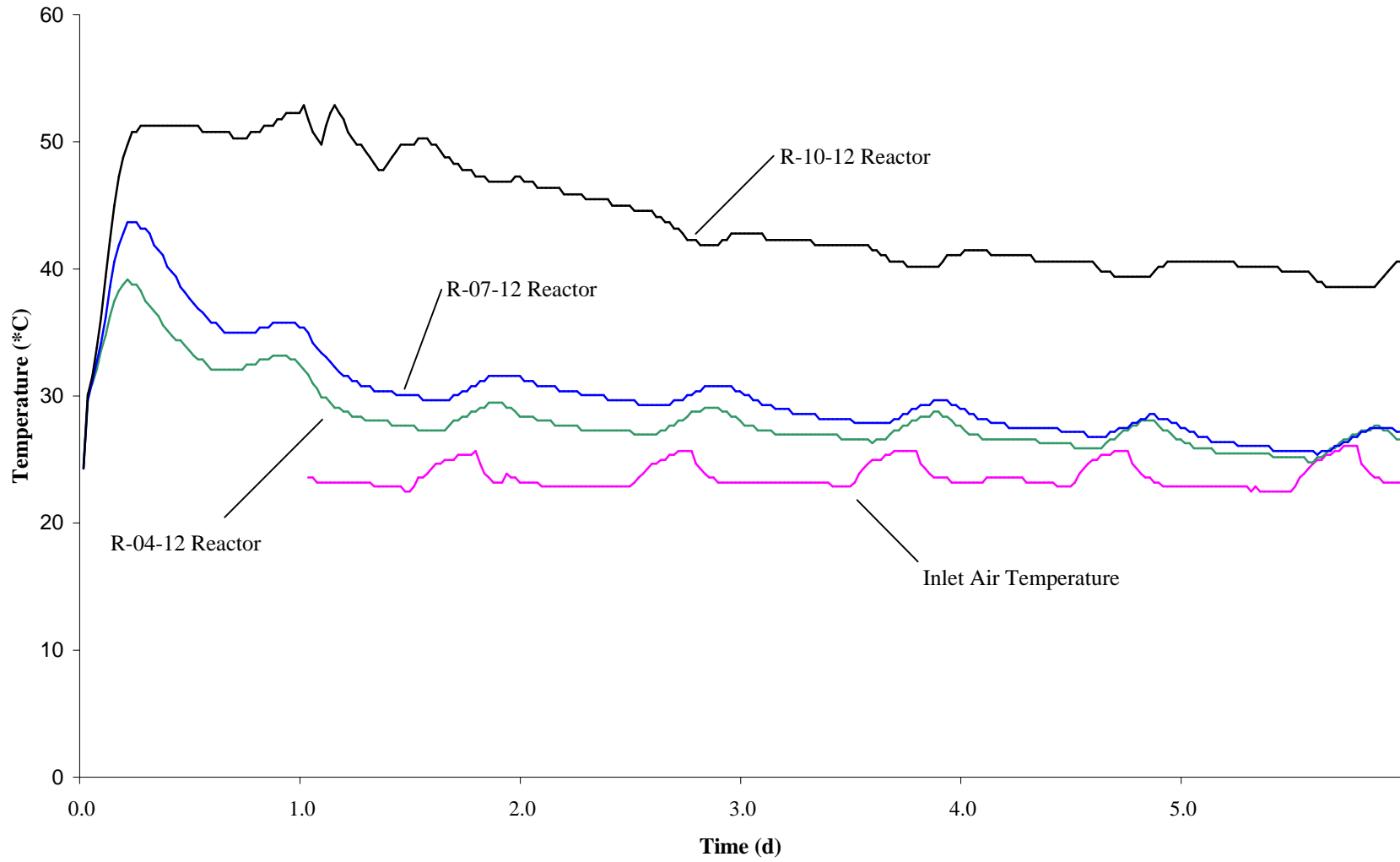

FIGURE E-1. Mix 1 Compost Temperature Profiles For Large Reactors

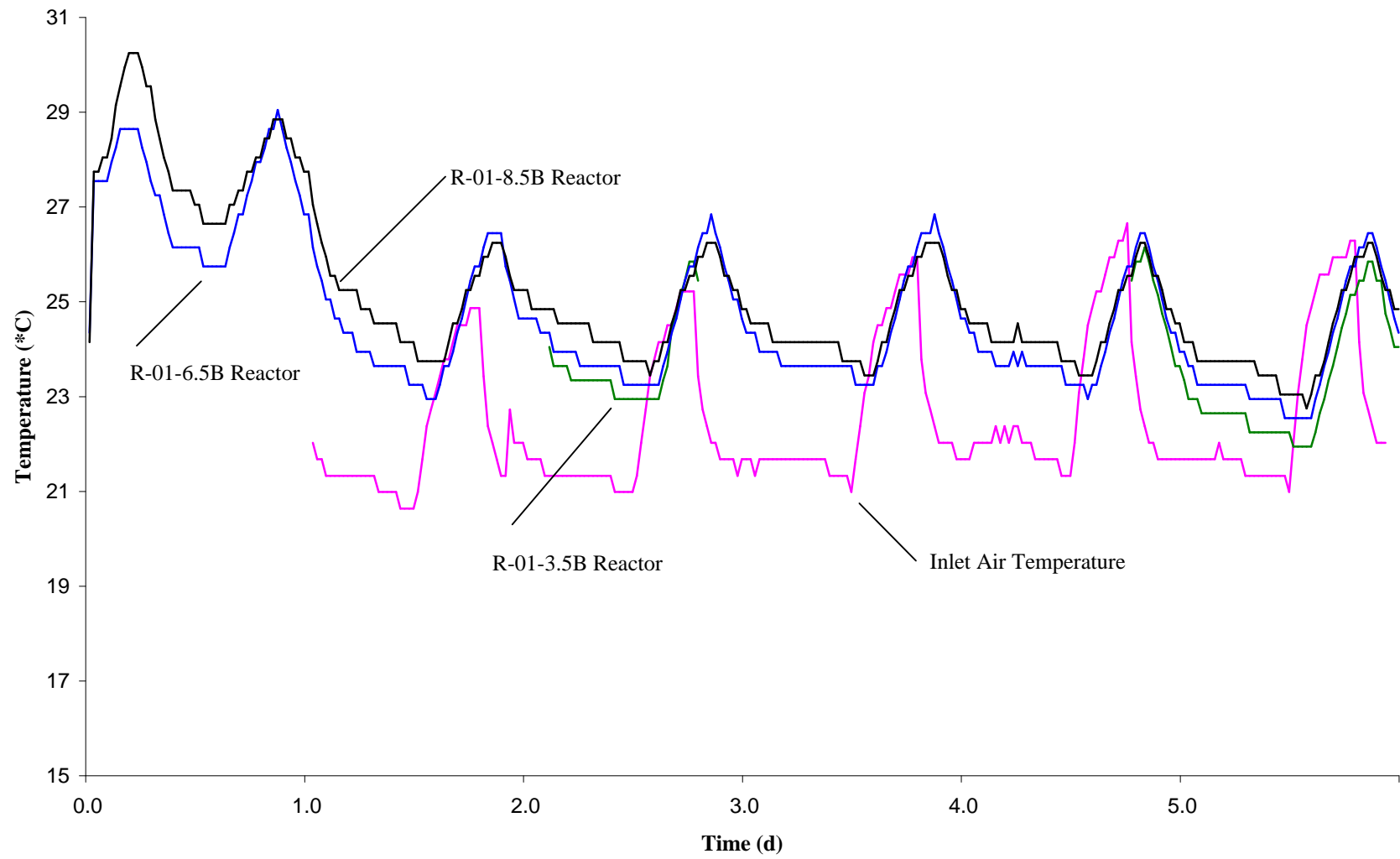

FIGURE E-2. Mix 1 Compost Temperature Profiles For Small Reactors

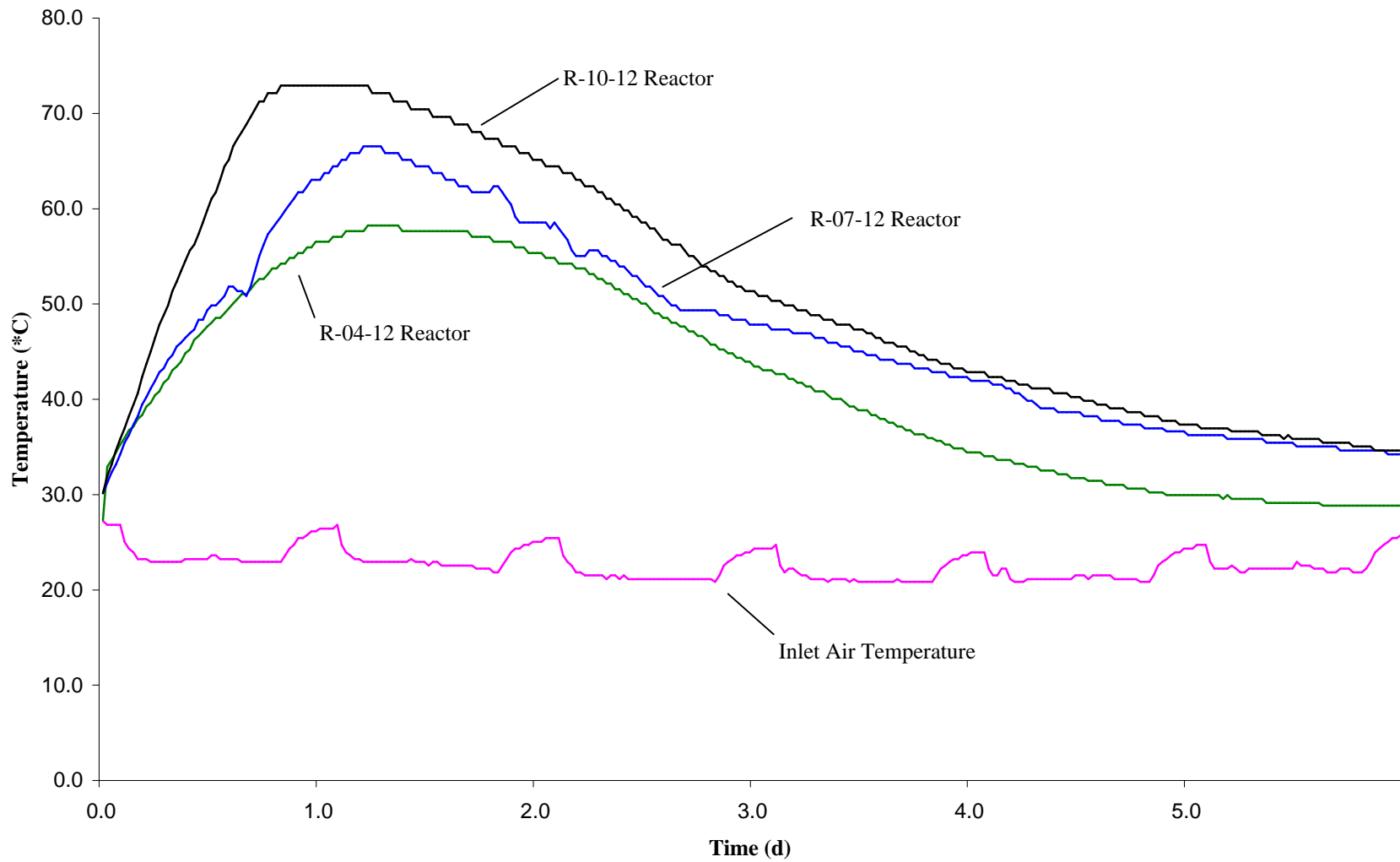

FIGURE E-3. Mix 3 Compost Temperature Profiles For Large Reactors

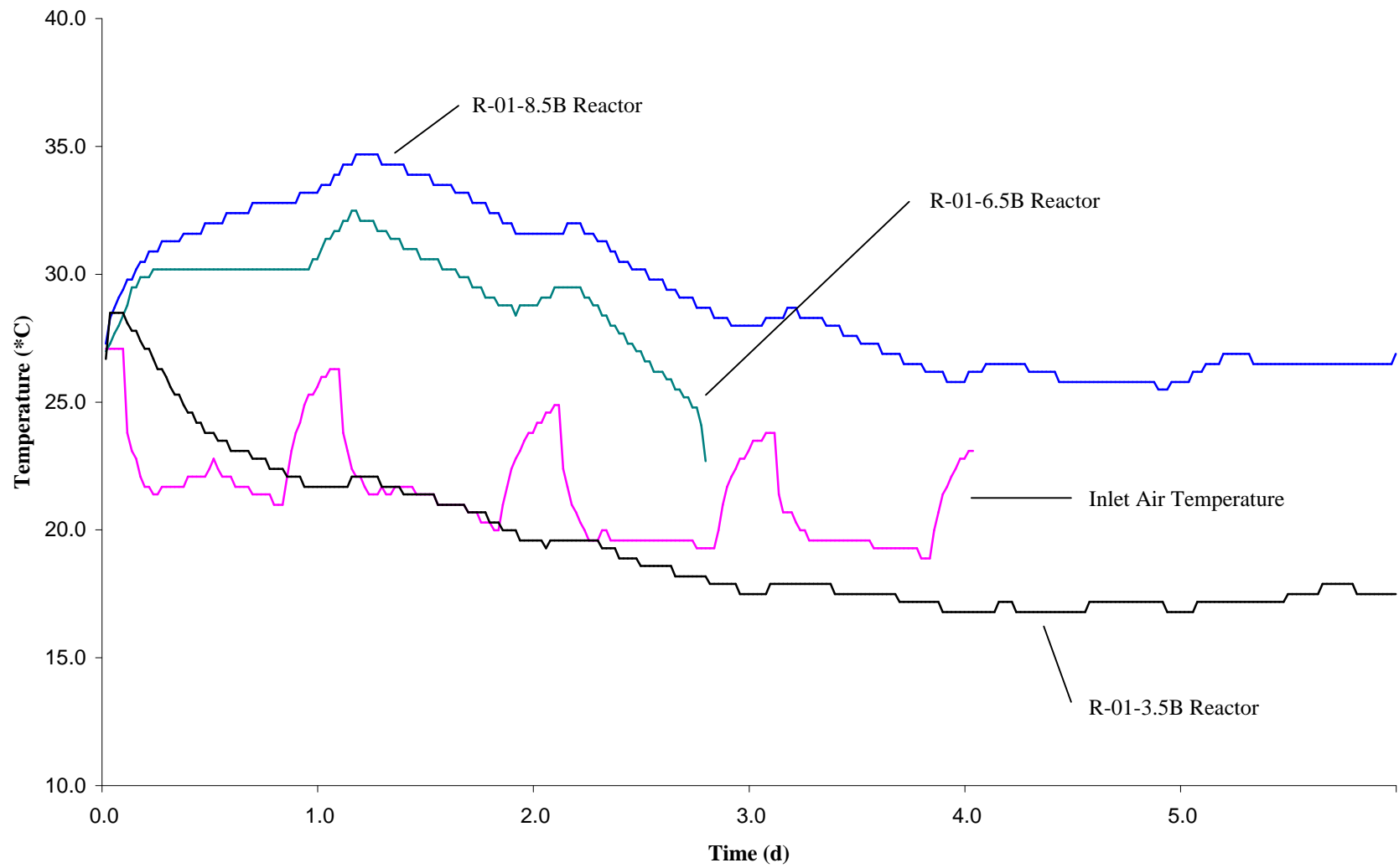

FIGURE E-4. Mix 3 Compost Temperature Profiles For Small Reactos

VITA

The author, Michael Alden Vining, was born on September 29, 1971, in Morgan City, Louisiana. He graduated from Morgan City High School in May, 1989. Five years later, he graduated from Texas Agricultural and Mechanical University, in College Station, Texas, in May, 1994, with a bachelor of science degree in civil engineering (with an emphasis in environmental engineering) from the Department of Civil and Environmental Engineering. After graduation, he was accepted for graduate study at Louisiana State University beginning August, 1994. After completing his course work and research in August, 1996, he took a position with J. Ray McDermott as a project engineer. In October, 1998, he took the oral examination. In January, 2000, he was appointed Public Works Director for the City of Morgan City. He is currently attending Louisiana State University in the pursuit of the completion of a master of science degree in Civil Engineering.