

SUPERCRITICAL FLUID EXTRACTION OF RICE BRAN WITH ADSORPTION ON RICE HULL ASH

A Dissertation
Submitted to the Graduate Faculty of the
Louisiana State University and
Agricultural and Mechanical College
in the partial fulfillment of the
requirements for the degree of
Doctor of Philosophy

In
The Interdepartmental Program in
Engineering

By
Paresh Manilal Patel
B.S., Gujarat Agricultural University, 1988
M.S., Gujarat Agricultural University, 1997
December, 2005

This dissertation is dedicated to
Varsha Patel
and
Nisarg Patel
for their endurance, inspiration,
encouragement, understanding and sacrifices
during the completion of this project.

Acknowledgements

I express my sincere appreciation and gratitude to my major professor Dr. Terry H. Walker, Associate Professor and Adjunct Faculty, Biological and Agricultural Engineering (BAE) Department for his guidance, advice, insight, availability and support from the beginning of my program to the completion of this dissertation. His keen interest in my research work, devotion of time for getting funding for the project and assistantship, inspiration during the course of study and preparation of this dissertation as well as keen interest in development of my career has made me greatly indebted to him. My study and research work for this dissertation also enjoyed invaluable guidance from Dr. J. S. Godber, Professor, Food Science. He was always available for my support, advice, help and encouragement during the course of this work. He served as a key personal resource for me to express my needs, problems and seek immediate help and guidance in absence of Dr. Walker. His help with solving technical issues, analytical work, getting support for this project and his encouragement during this project had made me grateful to him. Dr. Richard Bengtson, Professor, BAE Department served as co-chair for my committee. He also helped with getting financial support for this project and sorting out administrative issues. I am greatly thankful to him, as he was available for my support and advice in the time of need. I am thankful to Dr. Valsaraj Kalliat, Professor, Chemical Engineering Department for providing important engineering input during this project, providing encouragement and serving as committee member. I also express my sincere thanks to Dr. Charles Monlezun, Associate Professor, Experimental Statistics, for his help and guidance in planning of experiments, statistical analysis and serving as committee member. I express my gratitude to Dr. Ioan Negulescu, Professor, Human Ecology, for providing important input and suggestions in the planning stage and serving as a dean's representative in the advisory committee for this project.

Financial support received from LSU Agcenter, BAE Department, Louisiana Rice Board, and Functional Food Program is gratefully acknowledged. I express my gratitude to Dr. David Constant, Associate Dean, Engineering College, for providing financial support during the critical period of my study. I am thankful to Dr. Daniel Thomas, Professor and Head, BAE Department, for his support in getting financial help for attending conferences. I express deep appreciation and regards to Dr. Cay Drapcho, BAE Adjunct Faculty, for her valuable contribution in the initial stages of the project as well as help, guidance, suggestions and encouragement during my study. Support and guidance received from Dr. Steven Hall, Dr. Marybeth Lima and Dr. Cristina Sabliov is also gratefully acknowledged. My study as well as this project could not have been completed without day-to-day help, guidance, and administrative support from Ms. Danielle Bayham, Ms. Rohnda Shepard and Ms. Angela Singleton.

I am thankful to Dr. Zhimin Xu, Food Science, for his help with critical analytical aspects of this project. Contributions made by Jonathan Lamoureux in this project for going through the draft, making critical suggestions at various stages of the project as well as making experiences at BAE cheerful are invaluable. I express my thanks to Rebecca Christofferson (Exp. Stat.), Raghunathan Ravikrishna (Chem. Eng.), Rishipal Bansode (Food Sci.), Varshni Singh (CAMD), Pankaj Gupta (Mech. Eng.) for their invaluable help with different aspects of this project. I am also thankful to Tim Moran and Ortego Tyler for their help as student workers for this project. The support received from Sandeep Bhale during my study at LSU cannot be acknowledged in words. I am also thankful to Praveen Kolar, Erika Reeves, Hua Na, Liu Shufang, Mohan Bal, Rohit Badal, Kandasamy Nadarajah, Ankit Modi, Nitin Srivastava, Dilip Patel, Amogh Ambardekar, Sumit Singhal, for their company, help and support during my stay at LSU which kept my spirit alive and made life colorful.

I express my deepest affection, appreciation and thanks to my wife Varsha Patel and my son Nisarg Patel who supported me in my decision to come to the US, stayed alone for a long time, encouraged me with their love and understanding during difficult moments and also shared my joy and success. Both of them have made immense contribution to my study and life by their support, inspiration, understanding and sacrifices. It is to them that this work is dedicated.

Table of Contents

Acknowledgements.....	iii
List of Tables.....	viii
List of Figures.....	ix
Abstract.....	xii
Chapter 1	Introduction.....1
1.1	Rice Bran.....1
1.2	Rice Bran Oil and Its Nutritional Benefits.....2
1.3	Extraction of Bran Oil and Supercritical Fluid Extraction.....3
1.4	Rice Hull.....4
1.5	Rice Hull Ash and Adsorbent Properties.....4
1.6	Problems and Justification for Present Study.....5
1.7	Objectives.....6
Chapter 2	Review of Literature.....7
2.1	Rice Bran and Rice Bran Oil.....7
2.1.1	Physiology and General Characteristics.....7
2.1.2	Nutritional Aspects of Rice Bran Oil.....10
2.1.3	Chemical Composition and Structure of Important Components of Rice Bran Oil.....15
2.2	Rice Hull and Rice Hull Ash.....15
2.2.1	General Introduction.....15
2.2.2	Rice Hull Ash as an Absorbent.....19
2.3	Properties of Rice Bran and Rice Hull Ash.....22
2.4	Conventional Rice Bran Extraction and Processing Methods.....23
2.5	Separation, Recovery and Analysis of Important Components of Rice Bran Oil.....27
2.6	Supercritical Fluids and Supercritical Fluid Extraction.....29
2.7	Supercritical Fluid Extraction of Lipids.....35
2.8	Supercritical Fluid Extraction of Rice and Other Bran.....38
2.9	Modeling of Supercritical Fluid Extraction.....41
2.9.1	Modeling of Solubility and Diffusion Relationship in Supercritical Fluid Extraction Processes.....41
2.9.2	Models Describing Supercritical Fluid Extraction of Lipids.....44
2.10	Adsorption Processes.....50
2.10.1	Introduction to Adsorption.....50
2.10.2	Mathematical Models for the Adsorption Process.....52
2.11	Combined Application of Supercritical Fluid Extraction and Adsorption Processes.....55

Chapter 3	Extraction of Rice Bran Lipids and Its Antioxidant Compounds with Supercritical Carbon Dioxide at Pilot Scale.....	57
3.1	Introduction.....	57
3.2	Mathematical Modeling.....	61
3.3	Materials and Methods.....	63
3.3.1	Supercritical Fluid Extraction.....	63
3.3.2	High Pressure Liquid Chromatography.....	63
3.3.3	Soxhlet Extraction.....	65
3.4	Results and Discussions.....	65
3.4.1	Total Oil Yield.....	65
3.4.2	Cumulative Extraction and Extraction Rates.....	69
3.4.3	Antioxidants in Rice Bran Oil.....	74
3.4.4	Comparing Solvent and Supercritical Extractions.....	78
3.4.5	Modeling Results for The Extraction Process.....	80
Chapter 4	Supercritical Fluid Extraction and Adsorption Processes for Rice Bran Lipids with Use of Rice Hull Ash.....	84
4.1	Introduction.....	84
4.2	Materials and Methods.....	86
4.2.1	Experimental Procedures.....	86
4.2.2	Mathematical Modeling.....	88
4.3	Results and Discussions.....	89
4.3.1	Total Oil Yield.....	90
4.3.2	Cumulative Extraction and Extraction Rates.....	92
4.3.2.1	Effect of Extractions Conditions.....	92
4.3.2.2	Mathematical Modeling of Extraction Process.....	97
4.3.3	Antioxidants in Rice Bran Oil.....	99
4.3.4	Effect of Ash Adsorption on Rice Bran Oil and Antioxidants.....	103
Chapter 5	Adsorption of Antioxidant Compounds on Rice Hull Ash from Rice Bran Oil.....	110
5.1	Introduction.....	110
5.2	Materials and Methods.....	114
5.3	Results and Discussions.....	117
Chapter 6	Summary and Conclusions.....	126
References	132
Appendix	Materials and Methods.....	150
Vita	157

List of Tables

Table: 2.1.1.1	Composition of rice bran.....	11
Table: 2.1.1.2	Composition ranges and caloric content of different rice bran.....	11
Table 2.1.1.3	Composition of crude rice bran oil.....	12
Table 2.1.1.4	Characteristics of refined rice bran oil.....	12
Table: 2.1.1.5	Comparison for fatty acid composition and physicochemical parameters for rice bran oil and other vegetable oils (% of total lipids).....	13
Table 2.1.1.6	Comparison of sterols and triterpenes in different oils.....	13
Table 2.2.1.1	Composition of rice hull.....	18
Table 2.2.1.2	Composition of rice hull ash.....	18
Table 2.6.1	Physical properties of common supercritical solvents.....	32
Table 2.6.2	Potential applications of supercritical fluids extraction in processing of natural and food products.....	33
Table 3.4.5.1	Property data obtained for the modeling of extraction process	81
Table 3.4.5.2	Values of partition co-efficient (K) and mass transfer coefficient (Kp) predicted using Goto model.....	81
Table 4.3.2.1	Modeling results for the co-efficient.....	98
Table 5.2.1	Quantitative analysis of rice hull ash used in experiments.....	115
Table 5.3.1	Freundlich parameters and enthalpy change.....	123
Table A.2.1	Details of experimental treatments.....	154

List of Figures

Figure 2.1.1.1	Rice kernel.....	8
Figure 2.1.3.1	Structures of major components of oryzanol.....	16
Figure 2.1.3.2	Structures of tocopherols and tocotrienols.....	16
Figure 2.4.1	Overview of the refining process for edible oil.....	26
Figure 2.6.1	Phase diagram for supercritical fluid.....	31
Figure 3.3.1	Pilot scale supercritical fluid Extractor used for the experiments.....	64
Figure 3.3.2	Flow diagram of the supercritical fluid extraction system used for the experiments.....	64
Figure 3.3.3	Normal phase chromatograph for tocopherol, tocotrienol and oryzanol.....	66
Figure 3.4.1.1	Total oil yield as affected by pressure (F=45 g/min, T=60 °C).....	68
Figure 3.4.1.2	Total oil yield as affected by flow (P=41.4 MPa, T=40 °C).....	68
Figure 3.4.1.3	Total oil yield as affected by temperature (P=55.2 MPa).....	68
Figure 3.4.2.1	Cumulative extract yield as affected by pressure at 40 °C with respect to flow rate (F).....	70
Figure 3.4.2.2	Cumulative extract yield as affected by flow at 60 °C with respect to pressure(P)	71
Figure 3.4.2.3	Cumulative extract yield as affected by temperature.....	73
Figure 3.4.3.1	Effect of pressure on concentration of antioxidants.....	75
Figure 3.4.3.2	Effect of flow on concentration of antioxidants.....	76
Figure 3.4.3.3	Effect of temperature on concentration of antioxidants.....	77
Figure 3.4.4.1	Comparison extraction yields for maximum and minimum of total yield in SFE after 4 hour compared to and petroleum ether extraction for 6 hours.....	79

Figure 3.4.4.2	Antioxidant Yields for SFE for 4 hours compared to petroleum ether extraction for 6 hours.....	79
Figure 3.4.5.1	Comparing model and experimental values for extraction	82
Figure 4.3.1.1	Total oil yield as affected by pressure in SFE with ash experiments.....	91
Figure 4.3.1.2	Total oil yield as affected by flow in SFE with ash Experiments.....	91
Figure 4.3.1.3	Total oil yield as affected by temperature in SFE with ash experiments.....	91
Figure 4.3.2.1.1	Effect of pressure on cumulative oil extraction with ash adsorption.....	93
Figure 4.3.2.1.2	Effect of flow on cumulative oil extraction with ash adsorption.....	95
Figure 4.3.2.1.3	Effect of temperature on cumulative oil extraction with as adsorption.....	96
Figure 4.3.2.2.1	Comparing model and experimental values for extraction With ash.....	98
Figure 4.3.3.1	Effect of pressure on concentration of antioxidants in SFE with ash experiments.....	100
Figure 4.3.3.2	Effect of flow on concentration of antioxidants in SFE with ash experiments.....	101
Figure 4.3.3.3	Effect of temperature on concentration of antioxidants in SFE with ash experiments.....	102
Figure 4.3.4.1	Comparing oil yield in SFE with ash experiments to other extractions.....	104
Figure 4.3.4.2	Comparing cumulative oil extraction in SFE experiment with and without ash.....	104
Figure 4.3.4.3	Comparing oryzanol concentrations in SFE experiment with and without ash.....	105
Figure 4.3.4.4	Comparing tocopherols concentrations in SFE experiment with and without ash.....	106

Figure 4.3.4.5	Comparing tocotrienols concentrations in SFE experiment with and without ash.....	107
Figure 5.3.1	Effect of time on adsorption of antioxidants.....	118
Figure 5.3.2	Adsorption of oryzanol at different temperatures.....	119
Figure 5.3.3	Adsorption of tocopherols at different temperatures.....	120
Figure 5.3.4	Adsorption of tocotrienols at different temperatures.....	121
Figure 5.3.5	Arrhenius plot for the antioxidant compounds.....	125
Figure A.1	Stabilized rice bran used for the experiments.....	151
Figure A.2	Rice hull ash used as adsorbent.....	151

Abstract

Rice bran oil was extracted using environmentally-friendly supercritical carbon dioxide at varying conditions. Experimental treatments included pressure (27.6, 41.4 and 55.2 MPa), temperature (40 and 60 °C) and flow rates (25, 45 and 65 g/min) of supercritical carbon dioxide. Extracts collected at different time intervals during 4-hour extraction runs in a 3-L extractor were analyzed for oil yield and antioxidants. Normal-phase HPLC was used for analyzing the extract for important antioxidant compounds of oryzanol, tocopherols, tocotrienols. Silica rich rice hull ash adsorbent was also incorporated in combined extraction-adsorption experiments under similar supercritical fluid conditions. Supercritical extraction yields of rice bran oil and antioxidants were compared with 6-hour Soxhlet extraction using petroleum ether solvent. Total oil extract yields for SFE (17.26-18.52 %) and experiments conducted with ash (17.35-18.99 %) for the extraction conditions of higher pressure (55.2 MPa) and flow rates (65 g/min) were comparable to the ether extractable oil yield (17.88 %). Extract yield significantly increased ($p < 0.05$) with an increase in pressure and flow rate. However, the temperature effect on extract yield was not significant. Antioxidant extraction significantly increased with increased pressure, but not with increased flow and temperature. These behaviors with pressure, flow and temperature were similar for oryzanol, tocopherols and tocotrienols. Rice hull ash adsorbent did not significantly affect oil yields, but did influence the antioxidants in the extract. A much greater ash adsorption effect for noted for oryzanol, which was different from the effect that was seen for of vitamin E components. A separate batch adsorption study carried out at different temperature (20, 30, 40 °C) for varied time intervals also showed similar adsorption behavior. Freundlich isotherms successfully described adsorption behavior of the antioxidant compounds in the batch study using rice bran oil-hexane miscella. Freundlich fitting parameters (k and $1/n$) were used to plot Van't Hoff- Arrhenius equations and calculate the change in enthalpy value

(ΔH) due to adsorption of antioxidants. Goto et al. (1993) model was applied to extraction yield data and successfully characterized extraction behavior. Values of partition coefficient K and mass transfer coefficient K_p were calculated and reported.

Chapter 1

Introduction

1.1 Rice Bran

Rice (*Oryza Sativa* L.) is grown over vast areas of land around the world and is a major staple food for more than half of the world population (Juliano, 1985). The Asian continent accounts for approximately 90 percent of rice production and is also the major consumer. In 1999-2000, land devoted to world rice production was 381 million acres. In 2004 –2005, global rice production was forecasted to be 397.8 million tons (milled basis). (Economic Research Service, 2004). The US share in global rice production is around 1.5 –2 %. Recently, US domestic market has grown to 60 percent of production. American rice production is concentrated mainly in the south with Arkansas contributing a projected 4.81 million tons of the 10.23 million tons of US rice production forecasted for 2004-05. Louisiana ranks second in the total area and third with respect to total production of rice and is projected to contribute 28.1 million cwt of rice (Rice Outlook, 2004). Per capita consumption of rice in Asia was estimated as 104.32 kg per annum whereas the average global consumption per capita is 65.77 kg. American per capita consumption is 12.25 kg/year, but has nearly doubled in the past 20 years (Economic Research Service, USDA, 2004)

Rice is an excellent source of nutrients, where protein contains the eight essential amino acids. Rice is a relatively good source of thiamin, riboflavin, niacin, phosphorous, iron and potassium and is also a good source of carbohydrates, which serves as a form of energy. Non-allergenic and gluten-free characteristics make rice ideal for persons with these special dietary requirements (USA Rice, 2004).

Harvested rice is in the form of rough rice (paddy) with the edible portion covered with an outer protective layer known as the husk or hull. After being dried, the rice passes through sheller machines to remove the hull material. Shelling produces brown rice, with a thin bran layer surrounding the rice kernel. Abrasive forces in the milling machine remove the outer bran layer on the brown rice and the resultant product is white rice. White rice is consumed after appropriate polishing to further remove any remaining bran layers and to give a desired degree of whiteness and polish. The rice hull and rice bran are obtained as by-products of the rice milling industry (Juliano, 1985).

Rice bran, which includes the pericarp, the aleurone and subaleurone layers, parts of the germ and the embryo as well as small portions of the starchy endosperm (Houston, 1972; Saunders, 1990), is a valuable milling by-product. After milling, the immediate stabilization of rice bran using thermal treatment techniques deactivates enzymes responsible for its degradation. Stabilized rice bran is free from rancidity, off flavors, and bitter and soupy taste, and is suitable for further use and processing. (Randall et al., 1985; Saunders, 1986). Rice bran has gained significant attention after adequate progress in its stabilization techniques (Sarkar and Bhattacharya, 1991; Sivala et al., 1993; Proctor and Bowen, 1996; Lloyd et al., 2000). Bran, 10% of the weight of rough rice, is rich in oil (15- 22 %), depending on the milling procedure and the rice variety (Houston, 1972; Martin, 1994).

1.2 Rice Bran Oil and Its Nutritional Benefits

Rice bran is nutritionally rich, with 16 –22% lipid, 12 –16 % protein, 8-12 % crude fiber and high levels of other vitamins and minerals (Saunders, 1990). The high content of lipid makes bran a commercially viable feedstock for oil extraction. Rice bran has received increased attention as a product mainly due to the nutritional benefits of these lipid compounds. Crude rice bran oil contains triglycerides (68-71%), diglycerides (2-3 %), monoglycerides(5-6%), free fatty

acids (2-3 %), waxes (2-3 %), glycolipids (5-7 %), phospholipids (3-4 %) and unsaponifiables (4%) as lipids (McCaskill and Zhang, 1999). Rice bran oil (RBO) also contains nutritionally important antioxidant compounds, which include oryzanols, tocopherols and tocotrienols (Godber et al., 1994). These antioxidant compounds are beneficial in lowering cholesterol as well as preventing cardiovascular diseases (Lloyd et al., 2000). Tocopherols are also believed to have anticancer effects (Tarber and Packer, 1995; Dunford, 2001). Oryzanols are also believed to have cholesterol-reducing effects (Nicolosi et al., 1992; Dunford, 2000).

1.3 Extraction of Bran Oil and Supercritical Fluid Extraction

As a result of developments in the stabilization of rice bran and the increase in knowledge about health benefits associated with rice bran oil, extraction of RBO has received greater attention (Sayre et al., 1985; Kim et al., 1987; Sarkar and Bhattacharya, 1991; Gopala Krishna, 1993; Sivala et al., 1993; Proctor et al., 1994; Proctor and Bowen, 1996; McCaskill and Zhang, 1999; Lloyd et al., 2000). Solvent extraction is the conventional method used for recovery of lipids from rice bran. This extraction practice uses highly toxic and flammable solvents like hexanes, petroleum ether, isopropanol, etc. These solvents also have problems associated with waste disposal due to increased environmental concerns and regulations. Toxic solvent residues in the final food product are another concern. These issues have prompted scientists to search for alternative non-hazardous extraction techniques, of which supercritical fluid extraction (SFE) is a prominent alternative technique that promises to meet a growing demand for natural, green and organic extracts from food and biological materials. Supercritical carbon dioxide is the most widely used supercritical solvent in the food industry (Rozzi and Singh, 2002). Apart from carbon dioxide's non toxic and non-flammable nature, supercritical carbon dioxide extraction also offers the most important advantage of varying the extraction power of solvent by changing operating conditions such as pressure, temperature and flow rate.

This provides selective extraction and fractionation capabilities to the process. Carbon dioxide has a low critical temperature (31°C) making this SFE solvent ideal for biological materials like rice bran because of the possible degradation of thermally-labile bioactive compounds at higher temperatures.

1.4 Rice Hull

The rice hull (husk) also constitutes an important by-product of the rice milling industry as it accounts for approximately 20% of the paddy's weight. Rice husks are rich in cellulose (28-36 %), crude fiber (34.5-45.9 %) and ash (13.2 –21.0 %) (Juliano, 1985). The milling method and the rice variety influence the constituents in rice husk by- product. The environmentally sound disposal and use of large quantities of hull is a challenging issue for rice processors around the world. The use of rice hulls as animal feed has been reported in many countries like India but its value as a feed is still debated (Govind Rao, 1980). Increasing environmental concerns prevent the open burning of rice hulls and its low bulk density makes land filling costly due to the associated high transportation cost (Vallupilai et al., 1997). In countries like the US, where the rice milling industry is well organized and mills are large, rice hulls are burnt to generate thermal power for drying and other mill operations. Rice hull energy content ranges between 13.8 –15 MJ /kg (Juliano, 1985). Alternatively, one ton of rice husk is equivalent to 0.48 ton of coal or 0.36 ton of fuel oil (UNIDO, 1984). Agri-electric Corporation in Lake Charles, Louisiana, has successfully operated an electric generation plant based on rice hulls for the past twenty years and is providing directions for the use of rice hull for energy generation.

1.5 Rice Hull Ash and Adsorbent Properties

Rice husk ash (RHA) is an end product of the combustion of rice husk (or hull). Rice husk contains 13.2-21.0 % crude ash (Juliano, 1985). The bulk density of RHA is around 2,000 –2,300 kg/m³ (UNIDO, 1984). This hull ash also poses a potential waste disposal problem unless used in

a beneficial way. The chemical composition of ash varies according to the conditions in the gasifier used for burning the husk. RHA has a very high content of silica, which has very good absorbent properties. RHA has been used in cement manufacturing (Mehta and Pitt,1976; Cook and Suwanvitaya, 1981; Hamad and Khattab 1981; UNIDO,1984; Luh,1991). The ash has also been used as an antiskidding agent and in rubber compounding (Luh, 1980, 1991), an insulating material (Beagle,1978; Govind Rao,1980; Juliano,1985; Luh,1991) and soil conditioning agent (Beagle,1978; Govind Rao,1980; Sistani et al., 1997). In recent years, RHA has also been used as an adsorbent for wastewater components (Beagle, 1978; Mamipitiyarachchi, 1981; Pandya et. al., 1985; Ahmed and Ram 1992; Tiwari et al., 1995) and for oil components like free fatty acids, lutein, phospholipids and carotene (Brown and Snyder, 1985; Proctor and Snyder, 1987; Palaniappan, 1989, 1990; Palanippan and Proctor, 1990; Proctor et al., 1995; Liew et al., 1993; Farook and Ravendran, 2000; Chang et al., 2001; Chou et al., 2001).

1.6 Problems and Justification for Present Study

RBO has many medicinal and nutritional benefits (Orthpoefer,1996; McCaskill and Zhang, 1999), whereas RHA has high absorption properties for various natural oil components. Interest in environmentally friendly supercritical extraction technology is growing rapidly and is considered a promising extraction technique available for food and biological materials (Mohamed and Mansoori, 2002). Supercritical CO₂ extraction was observed to out-perform solvent (hexane and isopropanol) extraction for the extraction and fractionation of RBO and important components (Xu and Godber, 2000). Several studies address the supercritical extraction of RBO (Zhao et al.,1987; Ramsay et al., 1991; Saito et al.,1993; Gracia et al., 1996; Shen et al., 1996; Kuk and Dowd, 1998; Kim et al., 1999; Dunford and King, 2000; Xu and Godber, 2000; Badal, 2002), but more research efforts are needed to determine the best extraction conditions for various useful components of RBO such as tocopherols, tocotrienols

and oryzanols at the pilot scale. This would increase our understanding related to the fractionation of these compounds in RBO as related to the operating conditions of the SFE under large-scale extractions. Although the absorption of soya, sesame, palm and other oils by RHA have been studied (Brown and Snyder 1985, Proctor and Snyder, 1987; Proctor and Palaniappan, 1989, 1990; Palanippan and Proctor, 1990; Proctor et al., 1995; Liew et al. 1993; Farook and Ravendran, 2000; Chang et al., 2001, Chou et al., 2001), none have reported the absorption of RBO by RHA. Also, the combined effect of SFE and adsorption of the RBO on RHA have not been reported.

Therefore, the present study is an attempt to discern the effect of different supercritical extraction conditions on the extraction of nutritionally important RBO components and their absorption on RHA, using a pilot scale extractor. This would effectively combine the application of two rice milling by-products in a single step and also identify another way for separation and concentration of nutritionally and medicinally important components of RBO.

1.7 Objectives

The present study was carried out with the following specific objectives:

1. Evaluate different supercritical CO₂ extraction conditions for the extraction of rice bran oil and the fractionation of its important components at pilot scale.
2. Study industrial rice hull ash for the adsorption of rice bran oil and fractionation of its components in the supercritical extractor.

Chapter 2

Review of Literature

2.1 Rice Bran and Rice Bran Oil

2.1.1 Physiology and General Characteristics

Rice cultivation is almost 7000 years old. The USA is one of the major exporters (4th) of rice despite its low share (1.5- 2 %) in global production. This is due to relatively low domestic consumption (12.25 kg/year per capita) compared to other major rice producing countries, where domestic production and consumption rates (up to 104.32 kg/year in Asia per capita) are high. Rice production in the USA is concentrated in six regions among which Louisiana is 3rd after Arkansas and California (Economic Research Services, USDA, 2004). In 2002, Louisiana produced 1,392,129 metric tons of rice from over 531,791 acres, representing \$122.8 million in gross farm value. Additionally, marketing, processing and transportation of rice added \$159.6 million. (Louisiana Summary, 2002).

Rough rice (paddy) (Figure 2.1.1.1) is composed of a white starchy rice kernel tightly surrounded by a coating of bran, enclosed in a tough siliceous hull. The outer most layer of the husk contains very little nutrients, but provides protection against insect infestation and fungal infestation (Juliano, 1985; Hu, 1995). Removal of the hull from the rice kernel in rice processing results in brown rice, which is called shelling. Brown rice consists of the endosperm (major part of rice, which is rich in starch and protein), surrounded by the outer bran layer rich in lipid, protein and crude fiber. When the husk is removed from paddy by shelling, the bran layer comes in direct contact with air, resulting in the development of off-flavor in brown rice due to its lipase enzyme. This makes it unacceptable to consumers. Moreover, the look of brown rice is not appealing due to its color (Saunders, 1990; Hu, 1995). Further processing of rice is required to remove the bran layers from brown rice to produce white rice (Barber and Barber, 1980; Hu

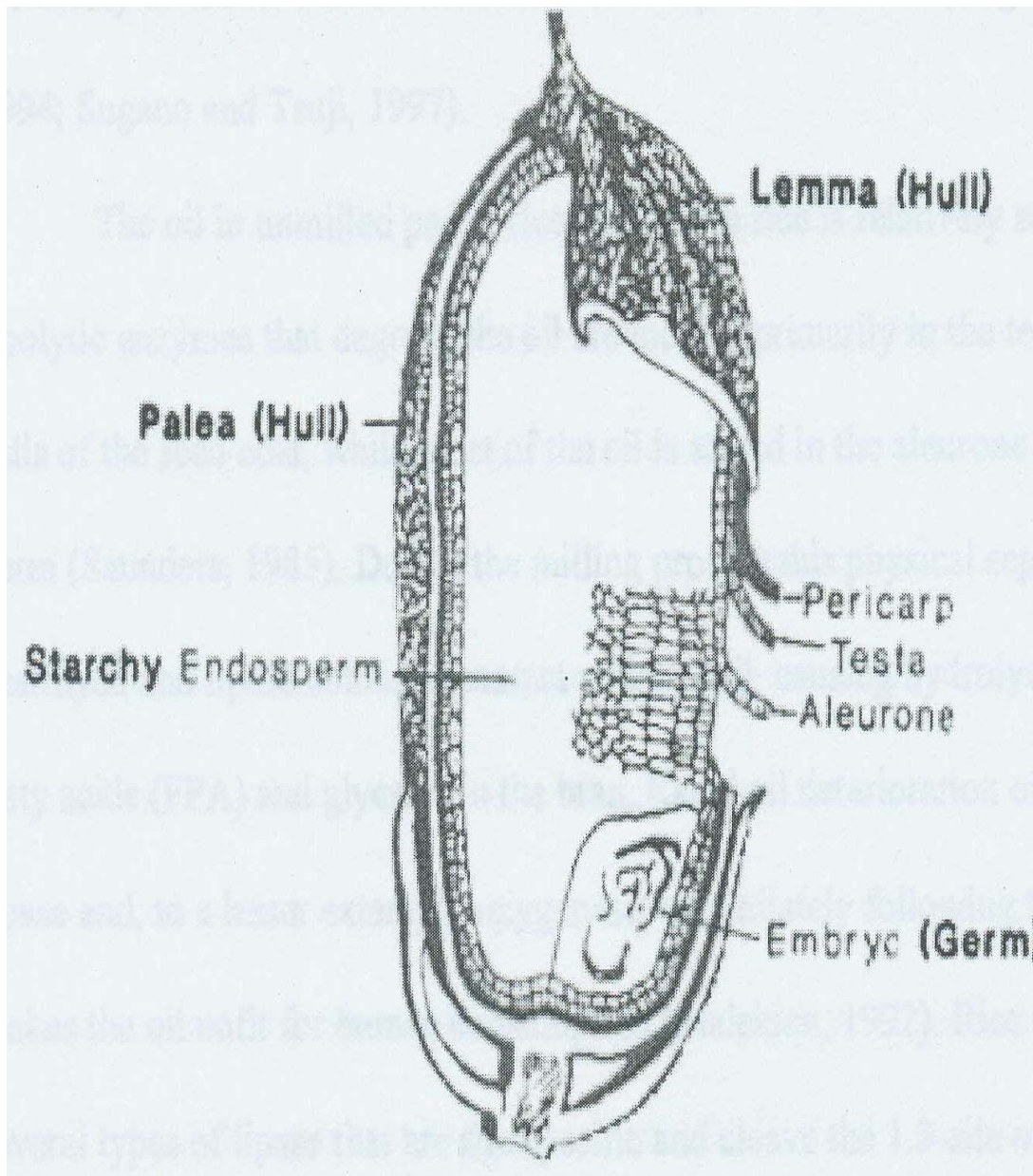

Figure 2.1.1.1 Rice kernel (Juliano, 1985)

1995). The process of removing the outer bran layer, which uses abrasive or frictional force, is known as milling or polishing.

Rice processing, until the past few years, was confined to drying, shelling, milling and polishing to produce white rice, resulting in loss of many nutrients through bran removal. The effective utilization of rice bran layers is possible by deactivating the lipase enzyme responsible for the hydrolytic degradation of rice bran constituents (Martin, 1994). Successful developments and use of various techniques, mainly heat and chemicals, to stabilize rice bran has occurred in the past two decades (Barber and Barber, 1980; Sayre et al., 1982; Rhee and Yoon, 1984; Juliano 1985; Randall et al., 1985; Prabhakar and Venkatesh, 1986; Saunders, 1990; Champagne et al., 1992; Malekin, 1992; Martin, 1994; Shin et al., 1997; Ramezanzadeh et al., 2000; Lakkakula et al., 2004). This has resulted in the emergence of rice bran as an important by-product of the rice milling industry.

The rice caryopsis is made of the pericarp (1-2%), aleurone, seed coat and nucellus (combined 4 %), embryo (2%) and endosperm (89 %). Rice bran is composed of fractions from the pericarp, the aleurone, the sub-aleurone layers, the seed coat, the nucellus along with the germ, or embryo, and a small portion of endosperm (Houston, 1972; Juliano, 1985; Salunkhe et al., 1992; Hargrove, 1994). The percentage and composition of rice bran vary according to the rice variety, any pretreatment before milling, such as parboiling, the type of milling system and the degree of milling (Gopal Krishna et al., 1984; Juliano, 1985; Saunders, 1990). Rice bran has a light tan color and is oily with a bulk density of 36.8-40.0 g per 100 ml, and constitutes almost 10 % of the rough rice weight (Houston, 1972; Hu, 1995). After a typical milling operation, nearly 86 –90 % of rice bran particles are typically less than 0.70 mm in size while 6-13% range between 0.70-0.85 mm (Juliano, 1985, Hu 1995). Rice bran contains 12-22 % oil, 11-17% protein, 6-14% fiber, 10-15% moisture and 8-17% ash (Saunders, 1990; Xu, 1998) (see Tables–

2.1.1.1 and 2.1.1.2). Rice bran is rich in vitamins and minerals, including vitamin E, thiamin, niacin, aluminum, calcium, chlorine, iron, magnesium, manganese, phosphorus, potassium, silicon, sodium and zinc (Juliano, 1985; Sunders,1990; Hu,1995; Xu,1998).

The importance of rice bran as a processed product is mainly attributed to its lipid content. Interest in rice bran oil is growing due to its various beneficial effects on health. Rice bran contains on average 16-22 % oil (Saunders, 1990). In 1996, world rice bran oil (RBO) production was 450,000 metric tons (MT), of which 100,000 MT was produced in Japan. USA RBO production potential was estimated to be 82,000 MT (Orthofer, 1996). RBO is widely used as edible oil in several countries such as Japan, Korea, China, Taiwan, Thailand and Pakistan (Rukmani and Raghuram, 1991). Crude rice bran oil contains 88 –89 % neutral lipids, 2-4 % free fatty acids (FFA), 3-4% waxes and 4.2 % unsaponifiables (Orthofer, 1996). RBO composition may vary according to the rice variety, composition of bran and the procedure employed for extracting bran (Fujino, 1978; Salunkhe et al., 1992). The composition of crude RBO is given in Table 2.1.1.3 whereas Table 2.1.1.4 gives details of important characteristics of rice bran oil. Rice bran oil has oleic acid (38.4 %), linoleic acid (34.4%) and linolenic acid (2.2%) as unsaturated fatty acids, and palmitic (21.5%) and stearic acid (2.9%) as saturated fatty-acids (Rukmani and Raghuram, 1991; Xu, 1998). Three major fatty acids palmitic, oleic and linoleic, make up 90 % of the total fatty acids of the rice bran oil. Rice bran is a good source of linoleic acid that is essential to human health (Ramezanzadeh et al., 2000). The free fatty acid (FFA) composition of RBO is similar to peanut oil except for unsaponifiable portion. Table 2.1.1.5 and 2.1.1.6 compares the fatty acids and sterols in rice bran and other vegetable oils.

2.1.2 Nutritional Aspects of Rice Bran Oil

In Japan, rice bran oil is popularly known as heart oil because it controls cholesterol (Sarkar and Bhattacharya,1991). The growing interest in rice bran oil is due to its high

Table: 2.1.1.1 Composition of rice bran

Component	%
Protein	15
Oil	18
Ash	7
Carbohydrates	50
Fiber	
Crude	7
Total dietary	28
Soluble fiber	2.4
Insoluble fiber	25.6

Source : Orthofer (1996)

Table: 2.1.1.2 Composition ranges and caloric content of different rice bran

Type of Bran	Moisture %	Protein %	Fat %	Crude Fiber %	Ash %	Calories per g
Rice bran	8-12	12-16	16-22	8-12	7-10	3.2
Parboiled rice bran (without calcium carbonate)	7-9	17-20	25-32	12-15	8-10	3.5
Parboiled rice bran (with 4-6% calcium carbonate)	7-9	14-18	23-27	10-13	10-13	3.5

Source: Saunders (1990)

Table 2.1.1.3 Composition of crude rice bran oil

Component	%
Saponifiable lipids	90-96
Neutral Lipids	88-89
Triglycerides	83-86
Diglycerides	3-4
Monoglycerides	6-7
Free fatty Acids	2-4
Waxes	3-4
Glycolipids	6-7
Phospholipids	4-5
Unsaponifiable lipids	4.2
Phytosterols	43
Sterolesters	10
Triterpene alcohols	28
Hydrocarbons	18
Tocopherols	1

Source: Orthoefer (1996)

Table 2.1.1.4 Characteristics of refined rice bran oil

Characteristic	Value for rice bran oil
Acid value	1.2
Iodine value	99-108
Saponification value	180-190
Smoke point	213 °C
Fire point	352 °C
Cloud point	17 °C
Refractive index 25 °C	1.470-1.473
Specific gravity	0.916-0.921

Source: Saunders (1991), Rukmini and Raghuram (1991)

Table: 2.1.1.5 Comparison for fatty acid composition and physicochemical parameters for rice bran oil and other vegetable oils (% of total lipid)

Fatty acid	Rice bran	Palm	Peanut	Cotton seed	Corn	Soybean	Safflower
Palmitic C _{16:0}	17	43	14	23	11	10	6
Stearic C _{18:0}	2	4	3	3	2	4	2
Oleic C _{18:1}	40	37	39	17	24	23	12
Linoleic C _{18:2}	34	9	36	51	58	51	74
Linolenic C _{18:3}	1	-	-	-	1	1	1

Source: Saunders (1991)

Table 2.1. 1.6 Comparison of sterols and triterpenes in different oils (% in oil)

Oil	Campesterol	Stigmasterol	β -sitosterol	Cycloartanol	Cycloartenol	24-methylene Cyloartanol
Rice Bran	0.506	0.271	0.885	0.106	0.482	0.494
Safflower	0.045	0.031	0.181	0.001	0.034	0.007
Corn	0.410	0.110	1.180	0.004	0.008	0.011
Sunflower	0.031	0.031	0.235	-----	0.029	0.016
Cottonseed	0.017	0.004	0.400	-----	0.010	0.017
Sesame	0.117	0.062	0.382	0.004	0.062	0.107
Soybean	0.072	0.072	0.191	-----	0.168	0.008
Groundnut	0.036	0.021	0.153	0.001	0.011	0.016

Source : Rukmani and Raghuram (1991)

unsaponifiable level (4.2 %) compared with other vegetable oils (Orthoefer, 1996; Lloyd et al., 2000; Dunford, 2001). Rice bran is a rich source of vitamin E (~300 mg/kg) (0.1-0.14%). Rice bran contains the major vitamin E components such as tocopherols (α , β , γ and δ) and tocotrienols (α , β and γ). Rice bran also has a high concentration of oryzanols (~3000 mg/kg) (0.9-2.9%). The unsaponifiable portion of RBO contains a unique complex of these naturally occurring antioxidant compounds, where tocopherols make up 1.0 % of unsaponifiables and tocotrienols make up about 1.7% of unsaponifiables. (Kato et al., 1981; Sayre and Saunders, 1990; Hu, 1995; De Deckere and Korver, 1996; Shin et al., 1997; Xu and Godber, 1999; Lloyd et al., 2000; Xu et al., 2001).

Oryzanols, tocopherols and tocotrienols, as antioxidants, give improved stability to the rice bran lipids and also improve the frying quality of the rice bran oil (Llyods et al. 2000; Yuki and Ishikawa, 1976; Duve and White, 1991; Sonntag, 1997; Xu, 1998). RBO also has a good balance of linoleic and oleic acids and has a low level of linolenic acids. Gamma oryzanol reduces cholesterol absorption (Rong et al, 1997) and reduces harmful cholesterol (LDL) without reducing good cholesterol (HDL). Oryzanols have been reported to promote growth, gonadotrophoic action, hypothalamus stimulation and hypolipidimic effects (Sugano and Tsuji, 1997). The antioxidant properties of these compounds were found to protect against vascular diseases and cancers in biological systems that result generally from cell damage caused by free radicals (Komiyama et al., 1992; Nestaretnam et al., 1998; Xu, 1998) and serum cholesterol (Orthoefer and Nicolosi, 1993). Various compounds of tocopherols and tocotrienols make up Vitamin E, which is a fat soluble antioxidant that protects cell membranes by blocking the oxidation of the unsaturated fatty acids and acting as a scavengers of free radicals (Bourgeois, 1992; Hu, 1995). Rice bran oryzanol has also shown a beneficial effect for the treatment of bone osteoporosis (Godber et al., 2001).

2.1.3 Chemical Composition and Structure of Important Components of Rice Bran Oil

Several studies have reported the details and composition of important components of rice bran oil. Oryzanols are a mixture of ferulate (4-hydroxy-3-methoxycinnamic acid) esters of sterols (campesterol, stigmasterol and β -stigmasterol) and triterpene alcohols (cycloartenol, 24-methylenecycloartanol, cyclobranol). Major portions of γ -oryzanol are cycloartenyl ferulate, 24-methylene cycloartanyl ferulate and campesteryl ferulate (see Figure 2.1.3.1). γ -Oryzanol is 1.5–2.9 % of rice bran oil, is white or yellowish, tasteless powder with little or no odor and has a melting point of 137.5 to 138.5°C (Okada and Yamaaguchi, 1983; Juliano, 1985; Budavari et al., 1989; Hu, 1995; Xu, 1998; Xu and Godber, 2000).

Vitamin E, which is a mixture of tocopherols and tocotrienols, is a pale-yellow, viscous oil with a boiling point range of 200-220 °C at 0.1 mm Hg (Budavari et al., 1989, Hu, 1995). Tocopherols and tocotrienols differ in the number and position of methyl groups on the fused chromanol ring, and the absence and presence of three double bonds in isoprenoid side chain (Figure 2.1.3.2) (Hua, 2000). Major forms of tocopherols in rice bran oil are 5,7,8-trimethyltocol (α -tocopherol), 7,8-dimethyltocol (γ -tocopherol) and 8-methyltocol (δ -tocopherol). Similarly, major tocotrienol forms are 5,7,8-trimethyltocotrienols (α -tocotrienol), 8-dimethyltocotrienol (γ -tocotrienol) and 8-methyltocotrienol (δ -tocotrienol) (Diack and Saska, 1994; Hu, 1995; Xu, 1998; Xu and Godber, 1999; Hua, 2000).

2.2 Rice Hull and Rice Hull Ash

2.2.1 General Introduction

The rice hull (husk), which is the outer fibrous layer of the rice kernel, constitutes approximately 20% of the weight of paddy grain being processed. The production of over 510 million tons of rice produces nearly 100 million tons of rice hulls available from rice mills

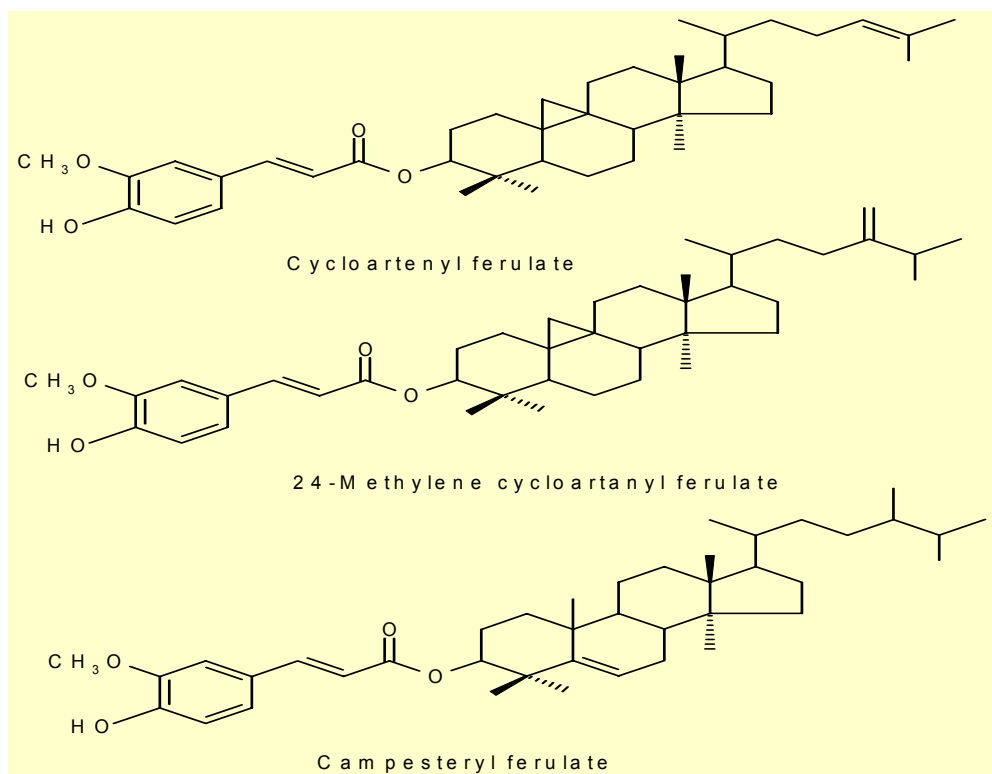

Figure 2.1.3.1 Structures of major components of oryzanols (Hua, 2000)

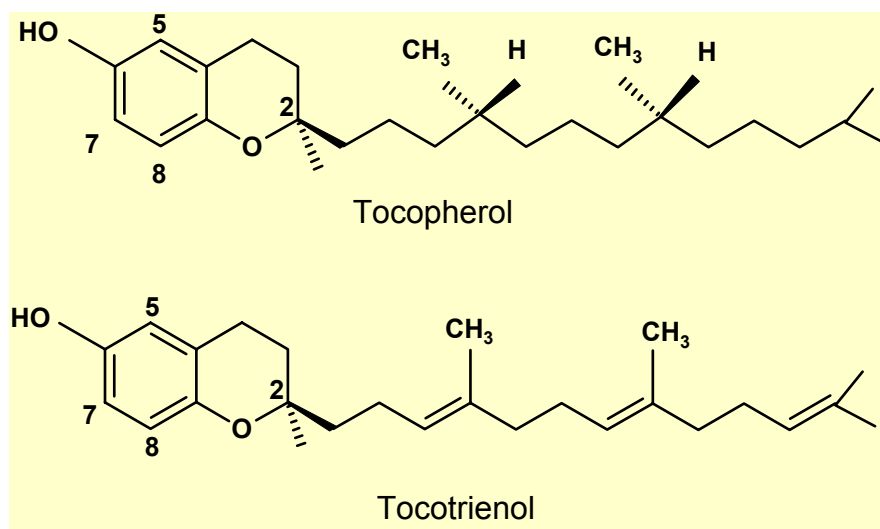

Figure 2.1.3.2 Structures of tocopherols and tocotrienols (Hua, 2000)

(Vellupillai et. al, 1997). The environmentally sound disposal or use of large quantities of rice hulls is a challenging issue associated with growing rice production. Rice husks, whose constituents are influenced by the milling method and variety, are rich in lignin, cellulose and ash. Table 2.2.1.1 and 2.2.1.2 gives the average composition of rice husks and rice hull ash respectively.

Over the past several years, attempts have been made in many parts of the world to utilize large quantities of rice hulls from rice mills in a beneficial way. Houston (1972), Beagle (1978) and Govind Rao (1980) had reviewed and listed various potential uses of rice husks. These include animal feed, bedding materials, soil conditioner, fertilizer, bio-fuel, a source of organic and inorganic chemicals, carbon, abrasives components, refractory and insulating materials, paper and board manufacturing, etc. An increased energy cost in all parts of the world has lead to increased applications and use of rice hulls as a renewable source of energy. The rice hull energy content at 14.0 % moisture content is 11.9 – 13.0 MJ/kg (5,116.5-5,589.4 Btu/lb) (Vellupillai et. al., 1997). In developing countries, like India, where rice milling industries are small and scattered, hulls are used as a part of brick kilns, as an ingredient in dung-cake, as components in goldsmith or blacksmith furnaces or as a fuel for water heating systems (Govind Rao, 1980). In developed countries, like the US, where rice mills are operating on a large scale and are concentrated, rice hulls have been used to generate energy for the rice mills themselves. A survey of seven American states reported 10-100% rice hulls being used in rice mill boilers (Vellupillai et al., 1997). There is an increasing trend towards use of hulls for energy generation in the US because it eliminates high transportation costs for disposing this low bulk density product, while saving fuel costs for the rice mill.

RHA is an end product of the rice husk energy generation system. RHA represents approximately 16-22 % by weight of husk (IRRI, 2003). Based on current rice production in the

Table 2.2.1.1 Composition of rice hull

Constituent	Proportion
Crude protein (% NX6.25)	1.9-3.0
Crude fat (%)	0.3-0.8
Crude fiber (%)	34.5-45.9
Available carbohydrates (%)	26.5-29.8
Crude ash (%)	13.2-21.0
Silica (%)	18.8-22.3
Calcium (mg/g)	0.6-1.3
Phosphorous (mg/g)	0.3-0.7
Neutral detergent fiber (%)	66-74
Acid detergent fiber (%)	58-62
Lignin(%)	9-20
Cellulose (%)	28-36
Pentosans(%)	21-22
Hemicelluloses (%)	12
Total Digestible nutrients (%)	9.3-9.5

Source : Juliano (1985)

Table 2.2.1.2 Composition of rice hull ash

Constituent	Weight (%)
SiO ₂	93.1
K ₂ O	2.3
MgO	0.5
Al ₂ O ₃	0.4
CaO	0.4
Fe ₂ O ₃	0.2
Na ₂ O	0.1

Source: UNIDO (1984)

US, even if 25 % of the hulls were used in the mill for energy generation, 102,300 tons of rice hull ash would be available. RHA can be used in widely varying areas such as cement manufacturing, insulation and refractory material, rubber compounding, antiskidding agent, water treatment etc. Beagle (1978) tabulated various possible uses of RHA in his report. But until recently, RHA was used primarily for production of cement. Mehta and Pitt (1976) conducted pioneering work to design an appropriate energy generation system for the utilization of rice husks to produce highly reactive ash, which can be successfully utilized for cement manufacturing. UNIDO (1984) published a detailed report on the potential use RHA for cement manufacturing.

The composition of RHA from energy production systems depends on the conditions of pyroprocessing. RHA is a very rich source of silica (>90 %). Typical constituents of RHA are listed in Table 2.2.1.2. RHA bulk density is in the range of 2,000 – 2,300 kg/m³ (Vellupillai et al., 1997). There are several studies that relate to the properties of RHA at various processing conditions (Hamad et al., 1981; James and Rao, 1986; Nakata et al., 1989; Proctor, 1990; Kamath and Proctor, 1998; Farook and Supramaniam, 2000; Kalapathy et al., 2000; Kalapathy et al., 2002).

2.2.2 Rice Hull Ash as an Absorbent

The cellulose of the rice hull is consumed in the burning process and leaves silica-rich ash as an end product. Due to its high silica content (>90%), RHA may serve as an excellent medium for adsorption processes. RHA has the potential to replace other conventional sorbent materials such as bleaching earth, clay, activated carbon, silicate, etc. in various industries. Goodwin and Mulkey (1986) have patented an adsorbent prepared from RHA mixed with alkali metal hydroxide and boric acid. Grease sweep consisting of RHA is used extensively for oil adsorption in spills and on floors in automobile workshops. In the past decade, few studies

relating to use of RHA as an adsorbent have been reported. These studies dealt with the adsorption of components from oils and wastewater. Kamath and Proctor (1998) used sodium hydroxide and sulfuric acid to produce rice hull silica gel (RHSG) from RHA, which was later compared to commercial silica gel (Trisyl 300). It was observed RHSG had a surface area of $258 \text{ m}^2/\text{g}$, half that of Trisyl 300, and the particle pore diameter of 121 \AA was twice that of Trisyl 300. The particle size of RHSG ranged from 5 to $45 \mu\text{m}$, whereas Trisyl 300 ranged from 5 to $25 \mu\text{m}$. The study indicated viability of producing commercial silica gel from RHA. Kalapathy et al. (2000) also successfully used alkaline extraction (NaOH) and acid precipitation (HCl) for the production of silica gel from RHA. Kamath et al. (2002) later improved their method for the production of silica from RHA by using citric and oxalic acids to reduce the sodium content in the final product from 4 % to below 1 %.

Few studies have examined adsorption of oil components with RHA. Soy oil adsorption with rice hull ash is the most extensively studied adsorption of oil on RHA. Further more, some of the studies indicated that adsorption characteristics of RHA were changed with acid activation (Pallaniappan and Proctor, 1990). When compared to that of commercial bleaching clay and silica hydrogel, RHA adsorbed more xanthophylls, lutein, phospholipids, free fatty acids and peroxides per unit of surface area. RHA was not as effective as silica hydrogel on the basis of weight of adsorbent used (Proctor et al., 1995). Soy oil phospholipid adsorption on acid activated rice hull ash was found to be higher for smaller doses of adsorbents (Proctor et al., 1992). Lutein's adsorption from soy oil on RHA increased with 5 % acid activation (sulfuric acid), but free fatty acid adsorption from soy oil decreased (Proctor and Pallanippan, 1989&1990). Soya oil adsorption studies for phospholipids using silica (Brown and Snyder, 1985; 1989), and for lutein using silicic acid (Proctor and Snyder, 1987) have also been reported.

Studies of adsorption of carotene from palm oil by RHA (treated with 20 % sulfuric acid, followed by washing with de-ionized water) indicated that unwashed acid activated ash was more effective. Relative adsorptive activities of acid-treated RHA were higher than carbon and silica, but lower compared to bleaching clay. Activity of ash was associated with preadsorbed acid (Liew et al., 1993). The adsorption of monoglycerides of palmitic and oleic acids was achieved from palm oil on RHA and yielded 15.84 mg adsorption per gram of ash in the case of monopalmitin (Ooi and Leong, 1991). Analysis of bleaching earth as an adsorbent for palm, palm kernel and coconut oil indicated surface area, particle size, pore size distribution and phosphorus content as important factors affecting adsorption behavior (Morgan et al., 1985).

The bleaching of sesame oil using RHA suggested activation by H_2SO_4 to be more effective than HNO_3 and HCl . Acid activation was able to increase adsorption up to 43 %. Here, the increase in adsorption capacity of acid activated ash was not related to an increase in specific surface area but was due to increased numbers of active sites. Impurities such as Al_2O_3 , Fe_2O_3 , CaO , MgO , Mn_2O , K_2O and Na_2O cover parts of the active sites and are removed due to acid activation making a higher number of the sites available for adsorption. Acid activation parameters such as acid type, concentration, activation time and ashing parameters such as ashing time and temperature may also affect adsorption efficiency of rice hull ash (Chang et al., 2001). When adsorption efficiency of RHA for free fatty acids and carotenoids from sesame oil was compared with commercial synthetic silica and wood carbon (vegetable carbon), RHA retained most of the oil, while silica had lower retention compared to wood carbon (Jorge et al., 2000). Studies of various parameters during the bleaching of sesame oil using acid activated rice hull ash indicated that RHA/acid ratio, speed of agitation during activation and pH had no effect on bleaching efficiency. Bleaching efficiency, however, increased with temperature up to 120°C (Lin et al., 2001).

A comparative study for the bleaching of rice bran oil, sunflower oil and groundnut oil with RHA prepared at 400°C for various time intervals suggested burning for 6-8 hrs produces ash of comparable efficiency to bleached clay (Vedanayagam et al., 1997). Decolorization studies on rubber and melon seed oil using fuller's earth, activated charcoal and their mixture (1:1) at three different temperatures produced Freundlich and Langmuir isotherms, which indicated the formation of a monolayer on the adsorbent. Also, an increase in adsorption with temperature due to an increase in active sites (Achife and Ibemesi, 1989) was observed. Rice bran oil bleaching using silica gel indicated column percolation as a more efficient method compared to shaking and decanting (Gopala Krishna, 1992)

Other studies involving RHA as an adsorbent for oil components include adsorption of saturated fatty acids (Farook and Ravendran, 2000), oleic acid (Proctor et al., 1995), lauric, myristic and stearic acids (Idris and Farook, 1994), myristic, palmitic and stearic acids (Huseyin and Yuksel, 1999) and rubber and melon seed oils (James and Rao, 1986). RHA is also suited for adsorption from other mediums apart from oil such as organic waste water substances from cargo red and vacuum pump oil in a packed bed (Chou et al., 2001), decolorization of raw sugar solutions (Ahmedna et al., 1997), protein adsorption (Jeyashoke et al., 1996), purification of bacteriocins from freeze dried culture supernatants (Janes et al., 1998), Hg (II) adsorption from aqueous solutions (Tiwari et al., 1995), basic blue dye adsorption from textile effluent (Ahmed and Ram, 1992) and adsorption treatment of textile dyes (Sumanjit, 2001)

2.3 Properties of Rice Bran and Rice Hull Ash

Properties of rice bran and hull ash are important for characterization and understanding extraction and adsorption processes. Physical properties such as particle size, shape, size distribution, porosity, bulk density, particle density, surface area, etc., are important for the present study. Tao et al. (1994) studied thermo-physical properties of bran from long and

medium grain varieties. They used USDA procedures for the determination of bulk density. Particle density was determined by taking the ratio of bran mass to the volume of solid particles and porosity was measured by the water displacement method. They observed the bulk density as 0.28 –0.29 g/cm³, particle density as 1.00 –1.08 g/cm³ and porosity as 72.10- 73.00 %. DeSouza et al. (2000) extracted silica from rice hull using three different processes and determined resulting silica physical properties for prospective applications in portland cement and mullite whiskers. The observed surface area was 280-480 m²/g. The average particle size was between 0.6 - 2.0 mm. James and Rao (1986) characterized silica obtained from RHA through the HF volatilization method using X-ray diffractograms and a scanning electron microscope (SEM). Surface area was determined with a physical adsorption analyzer. Color, chemical composition, crystal size and surface area varied significantly according to the method of ash production and processing time. An X-ray diffraction and SEM study for RHA silica by Proctor (1990) indicated silica-rich ash was composed mostly of lower order cristobalite and tridymite, with variable particle size. Kamath and Proctor (1998) produced rice hull silica gel (RHSG) from RHA and compared their chemical and physical properties to commercial silica gel- Trisyl 300. The surface area of RHSG was observed as 258 m²/g with a particle pore diameter of 121 Å and particles size ranged from 5 –40 µm.

2.4 Conventional Rice Bran Extraction and Processing Methods

Some agricultural products such as cottonseed, peanut and sunflower contain a high percentage of oil (30-35 %, 45-50 % and 50-55% respectively) whereas others such as soybean and rice bran are lower in oil (18-22% and 16-22%, respectively). High oil-bearing materials (>22%) are initially subjected to mechanical pressing using electric or hydraulic power and later extracted using solvents (Augilera and Stanley, 1990; Hu, 1995). Solvent extraction is widely used to extract oil from many cereals and rice bran because of its 16-18% oil and because high

oil recovery is achieved compared to mechanical pressing, with oil recovery of 10-12% of the oilseed (Juliano, 1985; Sivala et al. 1991,1993; Takeshita, 1993). In solvent extraction processes, solvent power of petroleum-based solvents (petroleum ether, hexane, ethyl alcohol, isopropanol, etc.) is used beneficially to extract lipid components from biomaterials (Salunkhe et al., 1992). The overall extraction process to obtain crude oil is comprised of flooding and washing lipids contained in the biomaterial with the solvent to produce a lipid-solvent miscella. The miscella is then heated to evaporate the solvent, which has a low boiling point. Hexane is the most predominant solvent for the extraction of rice bran oil (Johnson and Lusas, 1983). Hexane, however, is very toxic and exposure has a detrimental effect on the nervous system (WHO, 1991).

Particle size is an important factor influencing the extraction of the oil from bran. Sah et al. (1983) observed that for rice bran, the greater the length and diameter of the pellet (particle) the lower the surface area and the higher the extraction time. So, the surface area of the pellet should be maximized for more efficient extraction. In mechanical oil expression (pressing) studies for rice bran, Silva et al. (1993) were able to recover up to 45 % of the oil from the bran at 12.5 MPa pressure and a holding time of 45 minutes. Proctor et al. (1994) carried out laboratory-scale rapid equilibrium extraction from rice bran (2 g) by mixing it with hexane (20 ml) and stirring for different time periods (1, 2, 5, and 10 minutes). They observed that 90% of the oil was extracted in the first minute and 93% in 10 minutes. Oil obtained was low in phospholipids (42.7 ppm) and low in FFA (2.21). Proctor and Bowen (1996) compared hexane and isopropanol for the extraction of rice bran oil at ambient temperatures. At both levels of their study (2 g bran and 20 ml solvent, 30 g bran and 150 ml solvent), both hexane and isopropanol were found equally effective for extraction. Oil contained 2-3 % FFA levels, but oil extracted with isopropanol was more stable to heat oxidation compared to hexane-extracted oil, mainly

because of higher antioxidant levels in the isopropanol extract. Ohmic heating was found to increase the total lipid yield from rice bran compared to the control experiment without any heating (Lakkakula et al., 2004). Several studies of rice bran oil extraction using solvent extraction processes have been reported (Kim, 1987; Sayre et al., 1985; Talwalkar, 1965; Hu, 1995). These studies focused on effects of various extraction parameters such as the use of different solvents, extraction time, temperature, flow rates of solvent, and stabilization techniques, etc., to optimize the quantity and quality of rice bran oil.

The crude rice bran oil obtained from solvent extraction processes is not suitable for direct consumption. Apart from containing 80-90% triglycerides and 3-20% fatty acids, RBO also contains 2-5 % wax, 2% gum, 3-5 % unsaponifiables and different pigments (Sah et al., 1983; Bhattacharya and Bhattacharya, 1987; Mishra et al., 1988; Nicolosi et al., 1994). To obtain an edible oil of light color, the gum, waxes, FFA and pigments need to be removed. This refining process consists of steps such as degumming, dewaxing, deacidification, bleaching, winterization and deodorization (Juliano, 1985; Nicolosi et al., 1994; Hu, 1995). Figure 2.4.1 shows a general flow chart of the refining operations for producing edible oil from crude oil. All these steps have been described in detail elsewhere (Juliano, 1985; Hu, 1995; Greyt and Kellens, 2000).

Degumming involves using heat and acid treatment with centrifugation (Sarkar and Bhattacharya, 1991) whereas in dewaxing, the oil-solvent mixture is cooled for crystallization and centrifugation of the wax (Bhattacharya et al., 1983). The dewaxed and degummed crude RBO is deacidified using either alkali neutralization, reesterification, steam refining or distillation to remove FFA (Reddi et al., 1948; Kim et al., 1985; Sayre et al., 1985; Seetharamaiah and Prabhakar, 1986; Bhattacharya et al., 1986, 87, 89; Salunkhe, 1992). Bleaching is carried out to remove pigments, oxidized lipids and polar components of the oil using bleaching clay or silica gel. For salad oil production, RBO must be winterized to make the oil

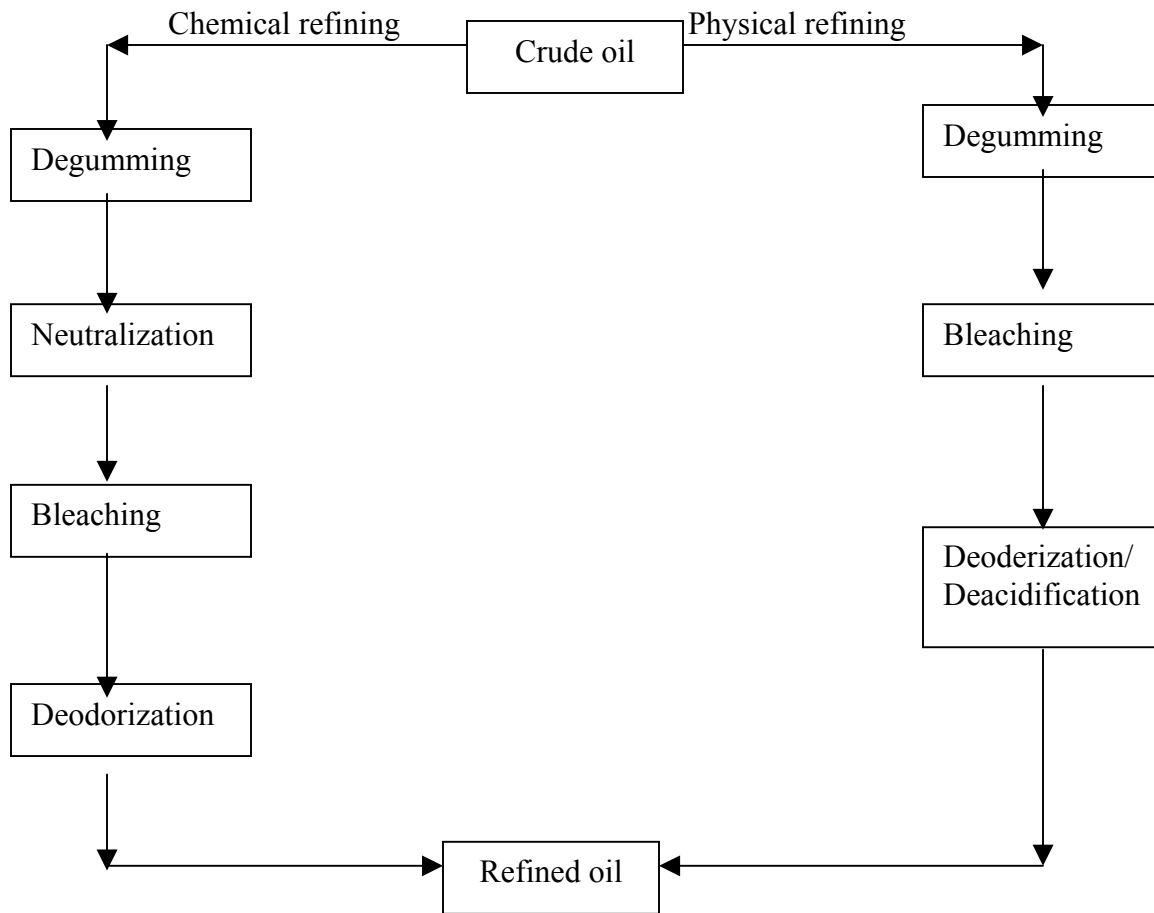

Figure 2.4.1 Overview of the refining process for edible oil
 Source: Greyt and Kellens (2000)

suitable for low temperature storage (Hu, 1995). Deodorization removes odors, off flavors and any remaining FFA using steam distillation (Baldwin 1948, Nicolosi et al., 1994).

Sarkar and Bhattacharya (1991) observed that nutritive characteristics of rice bran oil were significantly affected by the extent of purification. The coefficient of digestibility was slightly higher (94.8%) for oil that was dewaxed compared to that not dewaxed (93.8%). Gopala Krishna (1993), studied wax settling and refining of rice bran oil and concluded that monoglycerides must be removed before dewaxing. Oryzanols and phospholipids must then be removed to obtain oil free wax and to recover other by-products and reduce refining losses. Kim et al. (1985) found that steam refining was more effective than caustic refining in retaining natural antioxidants in the oil. Steam refining was also able to eliminate soap production. Crude RBO is difficult to refine and refining losses are higher (34-38%) with only 62 – 66% edible oil recovered from crude RBO, using a solvent extraction process without winterization (Hu, 1995; Yokochi, 1997). The extraction and refining of RBO for edible oil production may not be economically competitive with other edible oils such as cotton seeds, soybeans and corn, and may not be economically feasible unless rice bran oil is considered as a source of high-value nutritional components such as tocopherols, tocotrienols and oryzanols (Santos, 1992; Wells, 1993).

2.5 Separation, Recovery and Analysis of Important Components of Rice Bran Oil

Purification, separation, identification and quantification of the nutritionally important components of rice bran oil are of great interest and considered an important part of the present study. Few studies reported the recovery and separation of these components from RBO and other lipids. Recovery of α -tocopherol, β -sitosterol and other rice bran components such as Vitamin –B, fatty acids, lecithin and phytin, were investigated by Talwalker et al. (1965). Their process involved the refluxing of bran with ethanol (95%) in a 3:1 solvent ratio. The miscella

was saponified with sodium hydroxide for 30 minutes at higher temperature and was mixed with an equal amount of water after cooling before extracting it with petroleum ether. Up to 290-320 mg/kg of α -tocopherol and 500- 600 mg/kg of β -sitosterol were recovered from bran. There was almost a 50 % loss of α -tocopherol during saponification and ether extraction. Oryzanol with up to 80 % and 70 % purity can be produced using a pH adjustment method and absorption method, respectively (Okada and Yamaguchi, 1983).

Hu (1995) studied different processes (solid liquid extraction, saponification, liquid liquid extraction) for the optimal recovery of tocopherol, tocotrienol and oryzanol from rice bran. His study involved looking at the effects of parameters such as solvent-bran ratio (2:1 & 3:1 w/w), temperature of extraction (40 & 60 °C) and extraction time (5,10,15,20 and 30 min). He reported a recovery of 60 % vitamin-E and 70% oryzanol under optimum saponification and liquid-liquid extraction conditions. Budavari et al. (1989) identified eight compounds of tocopherol and tocotrienol making up vitamin E (α -, β -, γ -, δ -tocopherols and α -, β -, γ -, δ -tocotrienol). They also identified oryzanol as a mixture of ferulic acid esters of sterols (campesterol, stigmasterol, β -sitosterol) and triterpenealcohol (cycloartanol, cycloartenol, 24-methylenecycloartanol, cyclobranol). Xu (1998) isolated and identified ten fractions of γ -oryzanol with reverse-phase high pressure liquid chromatography (HPLC). Xu and Godber (1999) also discussed the use of normal and reverse phase HPLC for the extraction, purification and identification of different components of oryzanol from crude rice bran. Hua (2000) used fourier transform infrared spectroscopy (FTIR) to quantify γ -oryzanol and vitamin E.

Different silica columns were compared by Diack and Saska (1994) for the separation of vitamin-E and oryzanol from rice bran with normal phase HPLC and it was found that Nova-pack silica more effectively separated these compounds in comparison with other columns used

in the investigation. Gimeno et al. (2000) used reverse-phase HPLC with methanol-water mobile phase, ODS-2 column and UV detection at 292 nm for the direct measurement of tocopherols in vegetable oils. Chase et al. (1994) compared fluorescence and evaporative light scattering detection (ELSD), and found that fluorescence detection was highly sensitive (ten times higher) for identifying tocopherols compared to ELSD. Tan and Brzuskiwicz (1989) used different columns and mobile phases during normal and reverse phase liquid chromatographic analysis of tocopherols and tocotrienols. Shin and Godber (1993) discussed the normal phase HPLC method for vitamin E to improve the stability and reproducibility using acetic acid, ethyl acetate, acetic acid and 2,2 –dimethoxypropane (98.5, 0.9, 0.85, 0.1) mobile phase, in which acetic acid was helpful in reducing retention times and improving column stability. 2,2–dimethoxypropane reduced the need for column regeneration and stabilized retention times. Rogers et al. (1993) used reverse-phase HPLC with fluorescence and a photodiode array for detection of tocopherols, tocotrienols and oryzanol respectively. Yarita et al. (1994) used supercritical chromatography with a carbon dioxide mobile phase and a ODS – silica gel column for determination of tocopherols in vegetable oils. They observed the retention to be dependent on the density of carbon dioxide and concentration of methanol modifier in the mobile phase. The SFC results were in agreement with normal-phase HPLC determinations.

2.6 Supercritical Fluids and Supercritical Fluid Extraction

A supercritical fluid is defined as any substance that is above its critical temperature (T_c) and critical pressure (P_c). The critical pressure is the highest pressure at which a liquid can be converted into a gas by an increase in temperature, while critical temperature is the highest temperature at which a gas can be converted into liquid by an increase in pressure. In 1822, Baron Cagniard de la Tour was able to identify the appearance of a supercritical phase in a closed glass container (Clifford and William, 2000, Mukhopadhyay, 2000, Clifford 1999). In the

critical region there is only one phase, which possesses both gas and liquid-like properties. Figure 2.6.1 shows the phase diagram for a pure compound. A Supercritical fluid has both the gaseous property of being able to rapidly diffuse into a solid matrix and the liquid property of being able to dissolve materials into their components. Moreover, the solvating power of a supercritical fluid varies with a change in its density as a result of a change in pressure or temperature. Generally, for supercritical fluids at constant pressure, solvating power decreases with an increase in temperature, whereas, at constant temperature, the solvating power increases with an increase in pressure. Therefore, the solvating power of a supercritical fluid may be maximized by appropriate manipulations of both pressure and temperature. Hence the density of a fluid can be adjusted to solublize certain types of compounds in a selective way (Scneider et al.,1980; Stahl et al.,1988; Rizvi,1994; Kiran et al.,2000; McHugh and Krukoni,1994; Clifford, 1999; Mukhopadhyay, 2000). These properties of supercritical fluids make them an ideal solvent because of their high mass transfer properties as well as their selective extraction capabilities. They exhibit higher diffusivities, lower viscosities and very low surface tensions. Table 2.6.1 shows different properties of commonly used supercritical fluids. Apart from high diffusivities and low viscosities, supercritical solvents like carbon dioxide also offer gentle treatment of heat sensitive materials, and preserve natural fragrances and aromas of agricultural and biological products, such as nutraceuticals and traditional medicines.

McHugh and Krukoni (1994) have given a detailed historical perspective of the developments related to supercritical fluids. Supercritical fluid extraction technology, after initial ups and downs in its developments, started becoming an alternative extraction technology in many fields in the late 1980's and early 1990's. Possible applications of supercritical fluid extraction technology in the food and bioprocessing industries are summarized in Table- 2.6.2.

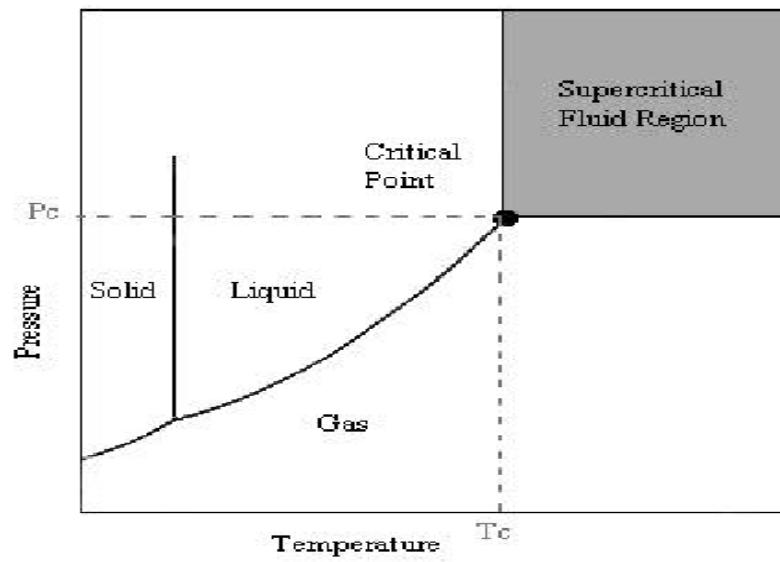

Figure: 2.6.1 Phase diagram for supercritical fluid

Table 2.6.1 Physical properties of common supercritical solvents

Fluid	Normal Boiling Point (°C)	Critical constants		
		Pressure (bar)	Temperature (°C)	Density (g/cm ³)
Carbon Dioxide	-78.5	73.8	31.1	0.468
Ethane	88.0	48.8	32.2	0.203
Ethylene	-103.7	50.4	9.3	0.20
Propane	-44.5	42.5	96.7	0.220
Propylene	-47.7	46.2	91.9	0.23
Benzene	80.1	48.9	289.0	0.302
Toluene	110.0	41.1	318.6	0.29
Chlorotrifluoromethane	-81.4	39.2	28.9	0.58
Trichlorofluoromethane	23.7	44.1	196.6	0.554
Nitrous Oxide	-89.0	71.0	36.5	0.457
Ammonia	-33.4	112.8	132.5	0.240
Water	100.0	220.5	374.2	0.272

Source: Klesper, 1980

Table 2.6.2 Potential applications of supercritical fluids extraction in processing of natural and food products

Sr. No	Application area
1	Decaffeination of coffee and tea
2	Spice Extraction (oil and Oleoresin)
3	Deodorization of oil and fats
4	Extraction of vegetable oils from flaked seeds and grains
5	Flavors, Fragrances, aromas and perfumes
6	Hops extraction from bitter
7	Extraction of herbal medicines
8	Stabilization of fruit juices
9	Lanolin from wool
10	De-oiling of fast foods
11	De-cholesterolization of egg yolk and animal tissues
12	Antioxidants from plant materials
13	Food colors from botanicals
14	Natural pesticides
15	De-nicotinization of tobacco

Source: Mukhopadhyay (2000)

The most commonly used supercritical fluid, as an extraction solvent, is carbon dioxide. It is relatively inert, non-flammable, non-toxic, easily available in a highly pure form and is environment friendly. Carbon dioxide has a low critical temperature (31°C), most suitable for thermally degradable biological and food materials, and has an easily attainable critical pressure of 7.38 MPa (1071 PSI). The phase diagram given in Figure-2.6.1 shows the supercritical region for carbon dioxide. Carbon dioxide is a non-polar fluid, has a solvating power comparable to hexane and is widely used for the extraction of non-polar compounds. Modifiers, in the form of appropriate solvents such as ethanol, may be used to extract polar compounds using carbon dioxide. The major problems associated with the conventional solvent extraction industry (flammability, possibilities of toxic residues, waste disposal regulations and environmental concerns) had resulted in increased attention towards supercritical fluid extraction. Supercritical fluid extraction (SFE), apart from overcoming problems associated with conventional solvent extraction, also offers additional advantages such as selective extraction and fractionation of high-value components in the extract at optimized extraction conditions. Increasing public consciousness towards healthy, natural and non-toxic products and growing environmental regulations has resulted as an impetus for the supercritical fluid industry. Moreover, the pharmaceutical, nutraceutical and food industries have also promoted developments in this area of research (Scneider et al., 1980; Stahl et al., 1988; McHugh and Krukoni, 1994; Rizvi, 1994; Clifford, 1999; Kiran et al., 2000; Mukhopadhyay, 2000). chemical engineering and thermodynamic aspects of supercritical fluids. Clifford (1999) and Kiran et al. (2000) dealt with the fundamentals of supercritical fluids. William and Clifford (2000) described process development using supercritical fluids. Supercritical fluid extraction from food, pharmaceutical, nutraceutical and other natural and biological products has received significant attention in the past several years. Rozzi and Singh (2000), Mohamed and Mansoori (2002) and Raventos et al.

(2002) reviewed applications of supercritical fluids in the food industry. Rizvi (1994), Awasthi and Trivedi (1997) as well as Mukhopadhyay (2000) enumerated extraction techniques from natural materials. King and List (1996) dealt with applications for supercritical fluid extraction for lipids and oils. Chen and Ling (2000), as well as Lang and Wai (2001), described applications of SFE technologies for herbal medicine. Apart from these detailed reviews and books, there are several other research publications on supercritical fluids for the extraction of various biological materials (Froning et al.,1990; Perker et al.,1992; Bhaskar et al., 1993; List et al., 1993; Tsuda et al.,1995; Cheung et al.,1998; Chester et al.,1998; Hulbert et al.,1998; Nguyen et al., 1998; Ambrosino et al.,1999; Galan et al., 1999; Ibanez et al., 1999, King, 2000; Senorans et al., 2001; Wong et al., 2001; Canela et al., 2002; Danaher and O'Keefe, 2002; Rozzi et al.,2002; Prieto et al., 2003). Tehrani (1993) suggested successful supercritical fluid extraction strategies. DeCastro and Carmona (2000), after reviewing advantages and limitations of supercritical fluid extractions, talked about future directions of the process.

2.7 Supercritical fluid extraction of lipids

Prospective application for the supercritical fluid extraction of lipids or oils, apart from common vegetable oils (soy oils, corn oil, rice bran oil, sunflower oil, olive oil, etc.), also include animal fats, fish oil, oil from sea weeds and oil from microorganisms like fungi etc. (Walker et al., 1999; Mukhopadhyay, 2000). Major components of lipids include monoglycerides, diglycerides, triglycerides, free fatty acids with minor constituents such as sterols, tocopherols, gums, alkaloids, flavonoids, wax and volatiles, which provide taste and odor. Most studies concerning SFE of lipids are focused on the optimization of extraction conditions to increase the yield of extractable materials (Hu, 1995). Several components of lipids have significant health and nutritional implications for the food and pharmaceutical industries. Polyunsaturated fatty acids (PUFA) have important therapeutic value. Unsaturated fatty acids

and saturated fatty acids have different health effects. Sterols, antioxidants, wax and volatile compounds also are significantly important for health. Major SFE applications include separation of FFA from vegetable oils, separation of PUFA from animal fats, refining and deodorization of vegetable oils, fractionation of glycerides, recovery of oil from biological materials, de-oiling of lecithin and de-cholesterolization and de-lipidation of food products (Mukhopadhyay 2000)

Eller (2000) reviewed the SFE of fat and observed that solubility of fats in supercritical carbon dioxide generally increased with pressure and temperature. At very low pressures, the solubility of fats is slightly higher at lower temperatures. He found that SFE of fat, however, worked best at high temperatures above 80 °C and pressure above 8000 psi or 55.16 MPa. Smaller particles yielded more oil as did dryer material. He described SFE as a promising technology for the extraction of small-scale, high-value products of fat bearing materials. SFE, apart from other advantages, limits auto-oxidation, decomposition and polymerization of omega-3 poly-unsaturated fatty acids such as eicosapentanoic acid (EPA) and docosahexanoic acids (DHA) in fish oil (Krukronsis, 1988 and Rizvi et al, 1988).

Bjergegaard et al. (1999) compared SFE and conventional solvent extraction for the extraction of volatiles and hydrophilic compounds from rapeseed, sunflower and soybean. SFE was useful for analytical purposes to obtain lipid content. Montanari et al. (1996) used supercritical carbon dioxide and a co-solvent (ethanol) for the selective extraction of phospholipids from soybean flakes. Taylor and King (2000) used analytical-scale SFE and SFC (supercritical fluid chromatography) for the optimization and fractionation of corn bran oil to achieve a high concentration of ferulate phytosterol esters (FPE). They extracted a maximum 1.25 % FPE from corn bran among the different combinations of temperatures (40, 60, 80°C) and pressures (13.8, 34.5, 69 MPa) tried during the experiments.

Eaggers and Sievers (1989) studied the SFE of rapeseed with different pretreatments and observed that flaked rapeseed cake and higher pressures were beneficial. Friedrich and Pryde (1984) applied SFE to soybean, cotton seed, corn germ, wheat germ and bran and observed that supercritical extracted oil was light colored compared to hexane extracted oil. Moreover, they observed some fractionation during the extraction, where more polar and higher molecular weight compounds were found to increase during later stages of the extraction process. Fattori et al. (1988) studied supercritical extraction of canola seed oil (25-90 °C, 10-36 MPa) and found that oil solubility in supercritical carbon dioxide was strongly dependent on pressure, but was not significantly dependent on temperature. Total oil recovery was also significantly dependent on the pretreatment of the seed (flaking, cooking, pressure rupture, chopping, crushing). Greater amounts of oil were recovered from flaked and cooked seed compared to whole seed.

Brown seaweed extraction with supercritical CO₂ (24.1- 37.9 MPa, 40-50 °C) was compared with Soxhlet extraction using chloroform/methanol (2:1,v/v) (Cheung et. al., 1998). Oil yields of SFE at 37.9 MPa (40/50 °C) were comparable to Soxhlet extraction. ω-3-Fatty acids concentrations were higher (31.4 %) in supercritical extract compared with Soxhlet extraction (23.5 %). For constant pressure (24.1 MPa), SFE yielded more lipids at 40 °C than at 50 °C . The concentration of total PUFA in oil decreased significantly and that of total saturated fatty acids increased significantly with increased pressure and solvent density

During olive oil de-acidification with supercritical carbon dioxide at different pressures (20 and 30 MPa) and temperatures (35-60 °C), CO₂ extracted fatty acids more selectively than triglycerides (at 60 °C and 20 MPa). Moreover the physical state of solute significantly affected solubility trends as a function of temperature and pressure. Supercritical fluid de-acidification of olive oil was found suitable, especially for oils with relatively high FFA (<10 %) due to a higher selectivity factor for FFA (Brunetti et al., 1989).

Studies on the extraction of spearmint oil (essential oil of *Mentha spicata*) from Turkish mint plant leaves with supercritical CO₂ indicated that concentration of the monoterpenes fraction in oil and oil yields were inversely related. SFE compared to conventional methods of hydro-distillation produced lower concentrations of the monoterpenes in the oil at low temperature that was safe for heat sensitive essential oil (Ozer et al., 1996). Lavender essential oil and wax extraction with supercritical carbon dioxide resulted in higher linalyl acetate content in oil (34.7%) compared with conventional hydro-distillation (12.1%) (Reverchon and Porta, 1995).

Other recent lipid extraction studies using SFE include canola oil (Bulley and Fattori, 1984; Temelli, 1992), citrus oil (Sato et al, 1988), menhaden oil (Nilsson et al., 1988), rapeseed oil (Eggers and Sievers, 1989), evening primrose oil (Favati et. al., 1991), soybean oil (List et al., 1993), soya, canola and corn germ oils (Taylor et al., 1993), peppermint oil (Motonobu et al., 1993), caraway essential oil (Sovova et al.,1994), soybean oil (Reverchon and Osseo, 1994), ginger oil (Roy et al.,1996), cloudberry seed oil (Manninen et al.,1997), sunflower oil (Perrut et al., 1997), pistachio nut lipids (Palazoglu and Balaban, 1998), almond oil (Marroene et al.,1998), lavender essential oils and waxes (Akgun et al., 2000), grape seed oil (Lee et al., 2000), hiprose seed oil (Reverchon et al., 2000) and Romanian mentha hybrids oil (Eugenia and Danielle, 2001)

2.8 Supercritical Fluid Extraction of Rice and Other Bran

In the past few years, attempts have been made to extract lipids from stabilized rice bran using SFE. Zhao et al. (1987) conducted the fractional extraction of rice bran oil with SFE at pressures of 14.7 to 34.3 MPa, and at a fixed temperature of 40 °C. They found differences in oil yield (18.6 to 22.0 %) extracted with pressures. Qualitative differences indicated that fractions obtained at high pressures contained less FFA and waxes or unsaponifiables in the oil.

Grinding of bran was also found effective in reducing the required carbon dioxide and extraction time. Ramsey (1991) compared different RBO extraction processes including solvent extraction (hexane), SFE and SFE with 5 % ethanol co-solvent. The oil yield was 20.2 % for solvent extraction, 18.0 % for SFE extraction and 18.2 % for SFE with modifier. For SFE and SFE co-solvent extractions, they used 35°C for 5 hr at a flow rate of 20.5 g/min in a 1-liter vessel at 30.0 MPa. They also compared concentrations of sterol components in the extracts, which were 9.4, 7.3 and 8.3 mg of sterol per g of rice bran oil for hexane, SFE and SFE-co solvent extractions, respectively. An entrainer (ethanol and chloroform) and separation columns were used by Saito et al. (1993) for SFE of RBO with carbon dioxide at 40-100°C and 8.2 –19.8 MPa. A separation column (silica gel supported nitric acid column) was effective in the fractionation of fatty acids whereas ethanol entrainer increased extraction efficiency up to 1.6 times. There was not much difference in FFA composition with or without entrainer. For example, C_{16:0}, C_{18:1}, C_{18:2} were 18.6, 42.5 and 35.1 % of total FFA for SFE extraction whereas their concentrations in SFE with ethanol extraction were 18.2, 43.1 and 35.4 %, respectively. Higher temperatures increased the fractionation of fatty acid esters.

King et al. (1996) used combined SFE (25 MPa and 80 °C) and supercritical fluid chromatography (SFC) (1.7 cm diameter and 20 cm long columns charged with 60-200 mesh silica gel, 16 g, in a preparative mode) to fractionate and enrich tocopherol components of the oil from soybean flakes and rice bran. Total tocopherol recovery and enrichments were observed as a function of the mass ratio of CO₂/seed charge. Also tocopherol recovery differed from one seed type to another. Garcia (1996) found that at 28 MPa and 70 °C (highest allowable system pressure and temperature in their system) they obtained 16-60 % of solvent extractable oil yield from rice bran. Oil obtained by SFE was lighter in color, high in waxes and had greater long chain fatty acids (C₂₀-C₃₄) compared to hexane-extracted oil.

Kuk and Dowd (1998) carried out SFE of rice bran (6 % moisture, below 0.297 mm particle size) at 48.26 & 62.05 MPa for 1.5 hours and reported 19.2-20.4 % RBO yield, compared to 20.5 % extraction yield using hexane in 4 hr. They also found increases in RBO yield with increasing temperatures at constant pressure. Sterol extraction was found to increase with increasing pressure and temperature. Kim et al. (1999) compared EFA (essential fatty acids) in rice bran oil extracted under different conditions (40, 50 & 70°C; 20.68, 27.58, 34.47 & 41.37 MPa). They found yields to be dependent on reduced density of supercritical carbon dioxide. Up to 70-80 % of RBO may be extracted in 4 hours. Xu and Godber (2000) compared solvent extraction (50% hexane & 50 % isopropanol v/v) of rice bran to supercritical carbon dioxide extraction at 50 °C and 68.9 MPa pressure for extraction of γ -oryzanol. Their study indicated that SFE extraction may extract up to four times higher γ -oryzanol (5.39 mg/g of rice bran) in less time compared to solvent extraction. Dunford and King (2000) studied extraction of RBO by supercritical carbon dioxide fractionation for reducing FFA and minimizing losses of phytosterols. From their experiments at the pressure of 20.5 to 32.0 MPa and temperatures ranging from 45 to 80°C, they found that low pressures and high temperatures reduced loss of triglycerides and phytosterols during removal of FFA from crude rice bran oil. Rice bran oil containing less than 1 % FFA, up to 95 % triglycerides, 0.35 % free sterols and 1.8 % oryzanol, may be obtained by SFE extraction. Badal (2002) studied the effects of particle size (16-48 mesh and >48 mesh) and bio-treatment with *Pythium irregulare* fungi, on the yield and the quality of rice bran oil extracted with supercritical carbon dioxide (40°C, 27.57 MPa, 200 standard cm³ per min). The extraction yield was approximately 50.0 % of the total ether Soxhlet extractable oil in 2 hours from the smaller particle rice bran. Eicosapentaenoic acid and arachidonic acid produced during the treatment by *Pythium irregulare* were extracted by SFE. Oil yield was found to be a function of particle size during SFE (p =0.0013), but not for Soxhlet ether extraction.

Taylor and King (2000) used SFE (13.8, 34.5 and 69 MPa; 40, 60, 80°C) to extract high-value ferulate phytosterol esters (FPE) from corn bran and they observed that highest levels of FPE (1.25%) were obtained in the extract at 69 MPa and 80°C as well as 34.5 MPa and 40°C. Furthermore SFE (34.5 MPa, 40°C) extracted corn bran oil with subsequent fractionation with SFC (amino propyl sorbent, commenced at 69 MPa at 80°C and subsequently lowered to 34.5 MPa at 40°C with addition of ethanol modifier at lower pressure) that produced up to a 14.5% FPE enrichment level. Dunford et al. (2003) used continuous counter-current supercritical fluid processing (CO₂ flow rate of 2 liter/min and oil flow rate of 0.7 liter/min) for de-acidification of rice bran oil at isobaric and isothermal conditions at a pressure range of 13.8 – 27.5 MPa and temperature range of 45-80°C and observed that fractionation at 13.8 MPa and 80°C was effective in de-acidification without loss of oryzanol.

2.9 Modeling of Supercritical Fluid Extraction

2.9.1 Modeling of Solubility and Diffusion Relationship in Supercritical Fluid Extraction Processes

Mathematical expression of kinetics of supercritical extraction phenomena can be of great significance for further studies as well as in understanding general behavior of extraction phenomena for given components. Knowledge of phase equilibrium behavior and generation of phase equilibrium data such as solubility, distribution coefficient and selectivity of separation of extractables in supercritical fluids is of great importance for improved understanding of the process. All applications of supercritical fluid extraction for food, flavor, fragrances and pharmaceuticals involve basic understanding of high pressure, fluid phase and equilibrium behavior. Most SFE applications involve multi-component systems. The common approaches for modeling has been to treat the SCF phase as a dense gas that may be represented using equations of state to calculate fugacity coefficients or to treat the SCF phase as an expanded liquid apart

from other approaches involving semi-empirical correlations or molecular models based on computer simulations. Though SCF phase behavior indicates some interesting trends, practical tasks to model and predict such behavior for qualitative and quantitative understanding pose serious challenges due to molecular complexities of solutes, uncertainties in specific interactions in dilute supercritical solutions at higher pressure and high compressibility of the SCF solvents. Agricultural and biological materials add to these challenges by their complex biological structures, which present many undefined variables for the technologist attempting to use supercritical fluids in their processing (Clifford, 1999; King, 2000; Mukhopadhyay, 2000).

Equation of state (EOS) is widely used to represent the solubility of solids in supercritical fluids. Solubility may be predicted as a function of the temperature and pressure along with solute and solvent properties. Some of the most commonly used EOS models are the Peng –Robinson and Soave-Redlich -Kwong equations. Both produce similar results. Equation of state (PR-EOS) will be discussed as it is more widely used. The PR- EOS equation is

$$P = \frac{RT}{v - b} = \frac{a(T)}{v(v + b) + b(v - b)}$$

where v is the molar volume, a accounts for intermolecular interactions between species of the mixture and b accounts for size differences between the species of the mixture. (Peng and Robinson 1976; McHugh and Krukoni, 1994)

Thermodynamic and phase equilibrium properties dictate the feasibility of the SFE process and conditions for maximum possible separations whereas knowledge of transport properties of supercritical fluids and resistances to the transport processes are required for calculating time required for the extraction and the sizes of the critical components of the plant (Mukhopadhyaya, 2000). Because of the rapid changes in properties such as viscosity η , diffusivity D , etc. with small changes in the conditions of the supercritical solvent around the

critical point, prediction of these properties are difficult and require sound theoretical considerations and understanding of the process.

Fick's law defines the molecular diffusion flux of a component with respect to the concentration gradient for a binary mixture. It states that flux is proportional to the concentration gradient and that diffusion of a compound occurs in the direction of decreasing concentration (Mukhopadhyaya, 2000). Fick's second law for a spherical geometry is given as

$$\frac{\partial C}{\partial t} = D \left(\frac{\partial^2 C}{\partial r^2} + \frac{2}{r} \frac{\partial C}{\partial r} \right)$$

with initial conditions $C = C_0$ at $t = 0$

and boundary conditions $\frac{dC}{dr} = 0$ when $r = 0$

$$C = C_\infty \text{ when } r = R \text{ and } t = \infty$$

Where, C = the concentration of solute in the sphere at time t

C_∞ = the final concentration of solute at the surface

D = the diffusion coefficient

r = distance from center of sphere

R = the radius of the sphere

The analytical solution takes the form of an infinite series with 'n' terms, for the total amount of a species diffusing from the sphere (Crank 1975):

$$\frac{M_t}{M_\infty} = 1 - \frac{6}{\pi^2} \sum_{n=1}^{\infty} \frac{1}{n^2} \exp \left(-\frac{Dn^2 \pi^2 t}{a^2} \right)$$

Where M_t and M_∞ represent the total amount of solute leaving the sphere at time t and total amount of solute extracted over infinite time, respectively. D represents the effective diffusivity for porous media with void volume, ϵ , and tortuosity factor τ (Walker, 1997).

2.9.2 Models Describing Supercritical Fluid Extraction of Lipids

The mass transfer rate for SFE for lipids from natural materials involving high initial concentration of extract (such as in oil seeds) in a fixed bed typically remains constant and then declines. SFE involves the control of solubility by manipulating temperature and pressure. Natural materials contain multiple components whose solubility and extractabilities are difficult to predict (Lira, 1996). Mathematical aspects related to SFE of lipids were discussed by King and List (1996), which included solubility (Maxwell, 1996), phase equilibria, mass transfer (Egger, 1996), fractionation (Peter, 1996) and modeling of SFE of lipids (Goodrum et al., 1996; Yoo and Hong, 1996).

Reverchon (1996) modeled supercritical extraction of sage oil from leaves at 9 MPa and 50 °C, for four different particle sizes. The model, based on a mass balance along the extraction bed, was proposed. Diffusivity of solute was the only adjustable parameter in their model. In their model a mass balance over an element of the extractor of height 'dh ' was written as:

$$uV \frac{\partial C}{\partial h} + \varepsilon V \frac{\partial C}{\partial t} + (1 - \varepsilon)V \frac{\partial \bar{C}}{\partial t} = 0 \quad (1)$$

$$\frac{\partial \bar{C}}{\partial t} = -\frac{1}{t_i} (\bar{C} - \bar{C}^*) \quad \text{Here } t_i = \mu \frac{l^2}{D_i} \quad (2)$$

with, initial conditions $t=0, C=0$ and $\bar{C} = \bar{C}_0$ and boundary conditions $h=0, C(0,t)=0$

where ε is the bed porosity, V is the extractor volume, C is the extract concentration in fluid phase, \bar{C} is the extract concentration in solid phase, \bar{C}^* is the concentration at the solid fluid interface, u is the superficial solvent velocity, μ is the coefficient dependent on particle geometry, D_i is diffusion coefficient, h is bed height and $l=V_p/A_p$ (particle volume / particle surface) is a characteristic dimension. Equations 1 and 2 also described for the fixed bed divided into n stages. Testing of the model with experimental results suggested internal mass transfer to

be controlling step for the extraction process. The particle's shape was important for modeling experimental data, with spherical shape giving a good fit.

Marrone et al. (1998) modeled supercritical extraction of almond oil from crushed almond seeds of three different sizes at 35 MPa and 40 °C. The following assumptions were made: the oil was considered a single pseudo component; the solute concentration was dependent only on time and the axial coordinates; uniform temperature, pressure, flow conditions along the extraction vessel; negligible axial dispersion and constant solid mass in the vessel during the extraction process were assumed. Their model was based on physical evidence of broken and intact oil cells and considered two different phases of the extraction process. The initial phase contained freely available oil and was contained within the broken cavities on the surface of the crushed particles and an oil phase was contained inside the particles or internal surfaces. A good fit was observed for experimental data with an internal mass transfer coefficient of 7.5×10^{-9} m/s.

Reverchon et al. (1999) tried to model the fractional extraction of fennel seed oil and essential oil in two stages. In the first step conducted at 9MPa and 50°C, essential oils were selectively extracted and then at 20 MPa and 40°C, the remaining vegetable oil was extracted. The flow rates tested were 8.33, 16.67 and 25 g/min. The model described vegetable oil extraction was based on differential mass balances around the concept of broken and intact cells, with the internal mass transfer coefficient as an adjustable parameter. Essential oil extraction was modeled as desorption from vegetable matter with a low resistance to mass transfer, having the same internal mass transfer co-efficient value as that of seed oil extraction. Both models represented good fits to experimental data.

An extraction model for pennyroyal essential oil by Vasco et. al. (2000) with extraction at 10 MPa and 50°C for different particle sizes (0.3, 05, 0.7 mm) and different CO₂ flow rates (18.6, 25.8, 37.2 g/min), utilized axial dispersion effects based on the desorption of oil near the leaf surface and mass transfer resistance in the internal part of the vegetable structure . They divided the extraction process, into two parts for the purposes of modeling. The first part of the extraction described adsorption equilibrium with superimposed axial dispersion, where as in the second part of the extraction process internal mass transfer was assumed as the controlling factor. Yield curves for all particle sizes and flow rates of carbon dioxide were fitted fairly well with an internal mass transfer coefficient K_i as an adjustable parameter. Akgun et al. (2000) described the extraction and modeling of lavender flower essential oil with supercritical carbon dioxide in a semi-continuous system at 8-14 MPa pressure, 35–50°C temperatures and 1.092-2.184 g/min flow rate ranges of carbon dioxide. They used a quasi-steady state model as a function of extraction time, flow rate, pressure and temperature with inter-particle diffusion coefficient as an adjustable parameter. The model was satisfactorily correlated with experimental data with best fitted value of effective diffusivity ($1.2 \times 10^{-11} \text{ m}^2/\text{sec}$).

Reverchon et al. (2000) conducted experiments for SFE extraction of hiprose seed oil at different pressures (10.34, 20.68, 41.37 and 68.94 MPa), temperatures (40, 50 and 70°C) and flow rates (1, 2, 4 and 6 g CO₂/min) with different particle sizes of seeds (0.42, 0.79 and 1.03 mm) and validated them with a mathematical model based on the structure of hiprose seed particles. For modeling purposes they assumed oil as a single pseudo component, the extraction bed was assumed to be continuous, and the pressure and temperature gradients along the column were neglected. The volume of the solid was assumed constant and the solute concentration in the fluid phase was assumed dependent only on time t and axial coordinates. Axial dispersion was neglected. Their model was given as

$$\frac{\partial C}{\partial t} + \frac{u}{\varepsilon} \frac{\partial C}{\partial z} + \frac{1-\varepsilon}{\varepsilon} \frac{\rho_s}{\rho_f} \frac{\partial q}{\partial t} = 0$$

$$\frac{\partial q}{\partial t} = K_i(Y)a(q - q^*)$$

$$q^* = K_{eq}C$$

$C = C_0$ at time $t=0$ for each z

$q = q_0$ at time $t=0$ for each z

$C = 0$ at $z=0$ for each t

Here u is superficial velocity of supercritical carbon dioxide, ε is void fraction of extractor, ρ_s is density of hiprose seed. ρ_f is density of supercritical CO_2 , Y is the yield of oil seed, a is specific surface of vegetable matter, K_{eq} is linear equilibrium constant, C and q are the concentrations expressed as a mass ratio of oil in fluid phase and solid phase, respectively, and q^* is the concentration of oil in solid phase at solid-fluid interface. Z is the axial coordinate, and K_i is the mass transfer coefficient. The model assumed internal mass transfer coefficient as linearly variable and fitted well to the experimental data.

Sovova (1994) and Sovova et al. (1994) modeled grape oil extraction at 28 MPa and 40 °C with grape seed of different particle size, flow rates and flow directions. Plug flow was observed for downward flow of compressed gas, whereas extraction was retarded by natural convection in the case of up -flow. The up-flow model with parallel plug flow more closely represented the extraction process. Roy et al. (1996) modeled oil extraction from freeze-dried ginger root as a function of flow rate of carbon dioxide, pressure, temperature and particle size. The extraction process was controlled by intra-particle diffusion within the root. The rate of extraction increased with small particle size due to a decrease in the diffusion path. A crossover effect was observed with temperature and pressure. High temperatures increased extraction rates at 24.5 MPa, but

low temperatures increased extraction at 10.8 MPa. A shrinking-core model with effective diffusivity and solubility as fitting parameters when applied to experimental results fitted the data for large particle sizes. Goodarznia and Eikani (1998) developed a two-phase model composed of solid and supercritical phases, which when tested for essential oil extraction showed a dependence on particle size and shape.

Kim et al. (1999) extracted and separated rice bran oil rich in essential fatty acids (EFA) using the SFE process. They described an extraction rate equation as

$$m(t) = K_g A_s V_t \Delta C_m$$

$$\text{Where } A_s = 6(1 - \phi)/d_p \quad \text{and} \quad C_m = \frac{C_{sat} - \sum C_{ext}(t)}{\ln \frac{C_{sat0}}{\sum C_{ext}(t)}}$$

Here $m(t)$ is the solute extraction rate at time t (g/sec), A_s is the specific mass transfer area (cm^2/cm^3), V_t is the total effective volume of the rice bran bed (cm^3) and ΔC_m is concentration difference of oil between the initial saturated and that extracted in the rice bran bed (g/cm^3). K_g is mass transfer coefficient (cm/sec). Dimensionless Sherwood number (Sh), Schmidt number (Sc), and Reynolds number (Re) were utilized as written below to correlate with the SFE extraction process, which was described as a hybrid process between natural and forced convection of the fluids.

$$Sh = C Re^{0.585} Sc^{1/3} \quad Sh = \frac{K_g d_p M_{av}}{\rho D_v} \quad Sc = \frac{\mu}{\rho D_v} \quad Re = \frac{\rho u d_p}{\mu}$$

Where d_p , M_{av} , ρ , μ and u are diameter of particle, molecular weight of carbon dioxide, density of carbon dioxide, viscosity of carbon dioxide and superficial velocity of solvent, respectively.

Re is the ratio of inertial to the viscous forces; Sc is the ratio of the momentum and mass diffusivities Sh gives dimensionless concentration gradient at the surface.

Goto et al. (1993) extracted peppermint oil with supercritical carbon dioxide at varying conditions (313-353 °K, 8.83-19.6 MPa) and studied extraction curves and extraction rates of major components (l-menthol and menthone). A mathematical model was also developed based on local adsorption equilibrium of essential oil lipid in leaves as well as mass transfer. Their model was based on the following assumptions: (1) leaves are porous solids with essential oil and lipid, (2) essential oils are extracted from leaves as if desorbed from solid biological tissue where lipids are associated with essential oils, and (3) essential oil dissolved in supercritical fluid diffuse to external surface and through the external film to be carried away by bulk flow. The adsorption equilibrium constant determined by fitting the theoretical extraction curve to experimental data increased with temperature and decreased with pressure.

Canela et al. (2002) applied the Goto model to supercritical fluid extraction of fatty acids And carotenoids from microalgae (*spirulina maxima*) to describe the extraction process. In their study to determine the kinetic parameters, extraction experiments were conducted at varying pressures (15, 16.5 and 18 MPa) and temperatures (20, 25 and 30 °C) where the yield and composition, which were determined at a constant solvent flow rate (3.33×10^{-5} kg/s). They applied the Goto et al. (1993)'s model assuming substrate as a porous matrix with diffusion occurring through the inside of the particle pores with mass transfer resistance being offered by the film around the particle. In their application the mass of extract at the bed out let was described by the following equation

$$m(t) = \left[\frac{\varepsilon_p}{K} + (1 - \varepsilon_p) \right] \frac{\varepsilon_p}{K} + (1 - \varepsilon_p) X_0 \rho_s Q_{CO_2} A \tau \left\{ \frac{1}{a_1} \left[\exp\left(a_1 \frac{t}{\tau} \right) - 1 \right] + \frac{1}{a_2} \left[1 - \exp\left(a_2 \frac{t}{\tau} \right) \right] \right\}$$

Here, A is a constant defined by the following equation

$$A = \frac{\phi}{\left[\varepsilon_p + (1 - \varepsilon_p) K \right] (a_1 - a_2)} \left(\frac{1 - \varepsilon_1}{\varepsilon_1} \right)$$

where, a_1 and a_2 are defined as

$$a_1 = \frac{1}{2}(-b + \sqrt{b^2 - 4c}) \quad a_2 = \frac{1}{2}(-b - \sqrt{b^2 - 4c})$$

$$b = \frac{\phi}{\varepsilon_p + (1 - \varepsilon_p)K} + \frac{1}{\varepsilon_1} + \frac{\phi(1 - \varepsilon_1)}{\varepsilon_1} \quad c = \frac{\phi}{[\varepsilon_p + (1 - \varepsilon_p)K]\varepsilon_1}$$

$$\phi = K_p A_p \tau$$

ε_1 =interstitial bed porosity

ε_p = particle porosity

K_p = combined mass transfer coefficient

A_p = specific surface area (1/L)

K = particle coefficient of solvent in solute

X_0 = initial solute mass ratio in the solid phase

ρ_s = solid true density (M/L³)

Q_{CO_2} = volumetric solvent flow rate (L³/T)

t = extraction time (T) and

τ = CO₂ residence time (T)

2.10 Adsorption Processes

2.10.1 Introduction to Adsorption

Kayser introduced the term “adsorption” in 1881 to denote the condensation of gaseous molecules on a surface. Adsorption is defined as the enrichment of one or more components on an interfacial layer and is the process by which molecules of a liquid or gas contact and adhere to a solid surface (Gregg 1982). Adsorption is an exothermic process and is caused by the forces acting between a solid surface (adsorbent) and molecules in the fluid phase (adsorbate). Adsorption processes may be either physical or chemical. Physical adsorption occurs when intermolecular van der Waals forces bind the adsorbing molecule to the solid substrate and the

process is reversible. Chemical adsorption occurs when covalent or ionic bonds are formed between the adsorbing molecules and the solid substrate and is not reversible (Davidson and McMurry,2000). In many adsorption processes, the adsorbate (the adsorbed component) from the fluid is held strongly to permit complete removal of that component from the fluid with very little adsorption of the other components. Regeneration or desorption of the component may be carried out to obtain adsorbate in concentrated form (McCabe and Hgriioff, 1985b)

Adsorption at various interfaces is an extremely important process of technological, environmental and biological importance for many industrial applications. The adsorption of substrates is used in many catalytic processes as a method for separating mixtures and for changing the concentration of components at the interface. Theoretical descriptions of adsorption have been achieved through the development of molecular models by means of computer simulation methods and with new technologies that examine surface layers or interfacial regions. In recent years, several new classes of solid adsorbents have been developed, such as activated carbon fibers, carbon molecular sieves, fullerenes, heterofullerenes, microporous glasses and nanoporous materials (Dabrowski, 2001).

The most common adsorbents are highly porous materials including activated carbon, activated alumina, silica, and zeolites. Silica is a finely divided mineral oxide whose surface properties have been studied extensively. Adsorption on silica is important for applications such as chromatographic media, catalysts and reinforcement agents for rubber. Silica has unique adsorption properties and production of refined silica adsorbents has widely affected the methods used for separating complex mixtures in the chemical, pharmaceutical, environmental and food industries. The production of chemically bonded silicas of desired type, sizes, shape, density and topography has made them an attractive substance for use in the separation industry (Paprier, 2000). Factors that affect the capacity of an adsorbent include its surface area, pore size and

polarity. Whenever a gas is in contact with a solid, equilibrium conditions between the molecules in the gas phase and the corresponding adsorbed species (molecules or atoms) will depend upon a number of factors such as relative stabilities of the adsorbed and gas phase of species involved, temperature of the system, pressure of the gas, etc.

2.10.2 Mathematical Models for the Adsorption Process

An adsorption isotherm is the equilibrium relationship between the concentration in the fluid phase and the concentration in the adsorbate particles at a given temperature and pressure. These isotherms are useful for indicating the affinity of an adsorbate for a particular adsorbent. The Langmuir isotherm was developed by Irving Langmuir in 1916 to describe the dependence of the surface coverage of an adsorbed gas on the pressure of the gas above the surface at a fixed temperature. Langmuir isotherms provide useful insight into the pressure dependence of the extent of surface adsorption. Langmuir derived a relationship for q (weight of component adsorbed for unit weight of adsorbent) and C (concentration of a component in a fluid) based on a few assumptions that include uniform surface, a single (mono) layer of adsorbed material and constant temperature. The rate of attachment to the surface should be proportional to the driving force multiplied by an area. The driving force is the concentration in the fluid, and the area is the area of non-adsorbed surface. If the fraction of covered surface is ϕ , the rate per unit of surface is given as,

$$q_{\text{in}} = \text{Rate going in} = k_1 C(1 - \phi)$$

where, ϕ = fraction of the surface covered

The evaporation from the surface is proportional to the amount of surface covered

$$Q_{\text{out}} = \text{Rate going out} = k_2 \phi$$

where k_1 and k_2 are rate coefficients

At equilibrium, the two rates are equal, and we find that:

$$k_1 C(1 - \phi) = k_2 \phi$$

that leads to
$$\phi = \frac{k_1 C}{k_2 + k_1 C}$$

By dividing the numerator and denominator by k_1 ,

$$\phi = \frac{C}{\frac{k_2}{k_1} + C}$$

Since q will be proportional to ϕ , and introducing q_m for monolayer and another constant k_a to replace k_2/k_1 , the useful form of the equation is

$$q = \frac{q_m k_a C}{1 + k_a C}$$

where: $q_m = q$ for a complete monolayer (amount of adsorbate adsorbed to form monolayer coverage on adsorbent)

and $k_a =$ Langmuir adsorption equilibrium constant.

Taking reciprocals and rearranging,

$$\frac{1}{q} = \frac{1}{q_m} + \frac{1}{q_m k_a C}$$

This equation describes the Langmuir isotherm in its linear form. Farook and Ravendran (2000) used the Langmuir isotherm to describe saturated fatty acid adsorption by acidified rice hull ash from palm oil. This linear form of the Langmuir isotherm described all fatty acid adsorption. Idiris and Adam (1994) also found that adsorption of FFA such as lauric, myristic and stearic acids on rice hull may be described with Langmuir isotherms.

Freundlich proposed an empirical relation for the amount adsorbed per unit weight of adsorbent versus the concentration in the fluid at the equilibrium given as

$$q = K_f C^n$$

where K_f and n are coefficients

q = weight adsorbed per unit wt of adsorbent

C = concentration in the fluid

Taking logs and rearranging

$$\log q = \log K_f + n \log C$$

Free fatty acid adsorption from soy oil by rice hull ash followed the Freundlich-type isotherm (Proctor and Palaniappan,1990). Adsorption efficiency of pine wood carbon, commercial silica and rice hull ash for the adsorption of free fatty acid and carotenoids were compared with the use of the Freundlich isotherm. (Vazquez et al.,2000). Langmuir and Freundlich adsorption isotherms were also applied to the bleaching of rubber and melon seed oil, which confirmed adsorption of the coloring compounds of oil followed monolayer adsorption and indicated an increase in active sites with rise in temperature (Achife and Ibemesi, 1989).

Brunauer-Emmett-Teller (BET) equation for adsorption exceeding the monolayer is given as:

$$q = \frac{q_m K_b C}{[C_a - C] + \{1 + [K_b - 1][C / C_a]\}}$$

where,

C_a = concentration at which all layers are filled

K_b = a coefficient

Assumptions for the BET equation were (1) adsorbed molecules do not move (2) enthalpy of adsorption is the same for any layer, (3) energy of adsorption is the same for layers other than the first, and (4) a new layer may start forming before another is finished.

Chen et al. (2003) discussed the kinetics of adsorption of β -carotene from soy oil with rice hull ash under vacuum in the detail. They used the following expression for the description of the adsorption rate

$$\ln \frac{C}{C_0} = - \left[k_0 \exp(-\Delta E / RT) d^{n_1} r^{n_2} \right] t^{1/2}$$

where C = pigment concentration at time t

C_0 = pigment concentration at time t = 0

K_0 = Frequency factor [$\mu\text{m}^{-n_1} \text{min}^{-0.5}$]

d = diameter of rice hull ash (μm)

ΔE = activation energy (J mol^{-1})

r = ratio of rice hull ash to soy oil

R = gas constant ($8.314 \text{ J mol}^{-1} \text{ K}$)

T = temperature ($^{\circ}\text{K}$)

n_1 and n_2 = exponents of d and r respectively

2.11 Combined Application of Supercritical Fluid Extraction and Adsorption Processes

Many food and pharmaceutical industries are looking into the integration of supercritical fluid extraction and other separation processes. Continuous supercritical adsorptive separation is one such process. Many products like pharmaceuticals could be processed more economically and with greater purity with combined supercritical fluid adsorption/desorption processes.

Cross and Akgerman (1998) discussed multicomponent supercritical adsorption phenomena and developed a dynamic model, taking into consideration of column dispersion, mass transfer and diffusive resistances. Experimental data predicted the breakthrough profiles with the model. Reverchon et al.(1998) successfully modeled the supercritical adsorption of a complex terpene mixture with a model that was based on the differential mass balance on fluid

and solid phases. Ambrogi et al. (2003) studied separation of natural colorants using combined high pressure (50 MPa, 100°C) extraction and adsorption (on silica gel) processes to separate carotene from natural sources. Sato et al. (1998) tried pressure swing adsorption of citrus oil with silica gel as an adsorbent. Adsorption isotherms were represented by the multi-component Langmuir equation. Their study included adsorption (at 8.8 MPa & 40 °C), desorption (at 19.4 MPa and 40 °C) and rinse step to determine the effect of feed concentration, half cycle time and flow ratio of carbon dioxide.

Chapter 3

Extraction of Rice Bran Lipids and Its Antioxidant Compounds with Supercritical Carbon Dioxide at Pilot Scale

3.1 Introduction

Rice bran, which includes the pericarp, the aleurone and subaleurone layers, parts of the germ, embryo and small portions of the starchy endosperm, is a valuable by-product of the rice milling industry. Bran, almost 10 % the weight of rough rice, is rich in oil content ranging from 15- 22 % depending on the milling procedure and the rice variety (Houston, 1972; Randall et al., 1985; Saunders, 1986; Martin, 1994). Crude rice bran oil contains 68- 71% triglycerides, 2-3 % diglycerides, 5-6% monoglycerides, 2-3 % free fatty acids, 2-3 % waxes, 5-7 % glycolipids and 3-4 % phospholipids with 4% unsaponifiable (Saunders, 1990; Caskill and Zhang,1999). Rice bran oil contains oleic acid (38.4 %), linoleic acid (34.4%) and linolenic acid (2.2%) as unsaturated fatty acids, and palmitic (21.5%) and stearic acid (2.9%) as saturated fatty acids (Rukmani and Raghuram, 1991; Xu, 1998). Rice bran is also a source of linoleic acid that is essential to human health (Ramezanzadeh et al., 2000).

The growing interest in rice bran oil is due to its high unsaponifiable level (4.2 %) compared to other vegetable oils (Orthoefer, 1996; Lloyd et al., 2000; Dunford, 2001). Rice bran is a rich source of vitamin E (~300 mg/kg) (0.1-0.14%) and has high concentration of oryzanols (~3000 mg/kg) (0.9-2.9%). (Kato et al., 1981; Sayre and Saunders, 1990; Hu, 1995; De Deckere and Korver, 1996; Shin et al., 1997; Xu and Godber, 1999; Lloyd et al., 2000; Zhimin et al., 2001). Vitamin E consists of components of tocopherols (α , β , γ and δ) and tocotrienols (α , β and γ). Oryzanols, tocopherols and tocotrienols are the antioxidant compounds that improve stability and frying quality in rice bran oil (Yuki and Ishikawa,1976; Duve and White, 1991; Sonntag, 1997; Xu, 1998; Llyods et al., 2000). Fat-soluble antioxidant compounds of Vitamin E

protect cell membranes by blocking the oxidation of the unsaturated fatty acids and acting as a scavenger of free radicals (Komiya et al., 1992; Nestaretnam et al., 1998). Gamma oryzanol is reported to reduce cholesterol absorption (Bourgeois, 1992; Orthoefer and Nicolosi, 1993, Hu, 1995; Rong et al, 1997). Oryzanols also have hypolipidemic effects, promote growth, gonadotrophic action and hypothalamus stimulation effects (Sugano and Tsuji, 1997)

Oryzanols are the mixture of ferulate (4-hydroxy-3-methoxycinnamic acid) esters of sterols (campesterol, stigmasterol and β -stigmasterol) and triterpene alcohols (cycloartenol, cycloartenol, 24-methylenecycloartanol, cyclobranol). Major portions of γ -oryzanol are cycloartenyl ferulate, 24-methylene cycloartanyl ferulate and campesterol ferulate. γ -Oryzanol is 1.5–2.9 % of rice bran oil and is white or yellowish tasteless powder with little or no odor (Kaneko and Tsuchiya, 1954; Okada and Yamaaguchi, 1983; Juliano, 1985; Budavari et al., 1989; Hu, 1995; Xu, 1998; Xu and Godber, 2000). Vitamin E, which is a mixture of tocopherols and tocotrienols, is a pale-yellow and viscous oil (Budavari et al., 1989, Hu, 1995). Tocopherols and tocotrienols differ in the number and positions of methyl groups on the fused chromanol ring, and the absence and presence of three double bonds in the isoprenoid side chain. (Hua, 2000). Major forms of tocopherols in rice bran oil are 5,7,8-trimethyltocol (α -tocopherol), 7,8-dimethyltocol (γ -tocopherol) and 8-methyltocol (δ -tocopherol). Similarly major tocotrienol forms are 5,7,8-trimethyltocotrienols (α -tocotrienol), 7,8-dimethyltocotrienol (γ -tocotrienol) and 8-methyltocotrienol (δ -tocotrienol), (Diack and Saska, 1994; Xu, 1998, Hu, 1995; Xu and Godber, 1999; Hua, 2000).

Solvent extraction is the conventional method for lipid recovery from rice bran that uses toxic and flammable solvents like hexanes, petroleum ether, isopropanol, etc. Proper disposal, toxic residue in final food product and environmental regulations represent key problems

associated with the use of these solvents. These issues have prompted scientists to search for alternative, non-hazardous extraction techniques. Supercritical fluid extraction (SFE) is a prominent alternative technique, which promises to meet a growing demand for natural, green and organic extracts from food and biological materials. McHugh and Krukonis (1994) have given a detailed historical perspective of the developments related to supercritical fluids. Supercritical fluid extraction (SFE), apart from overcoming problems associated with conventional solvent extraction, also offers additional advantages of the selective extraction and fractionation capability for high- value components in the extract at optimized extraction conditions. Carbon dioxide is the most widely used supercritical solvent due to its low critical temperature and pressure (31 °C, 7.10 MPa). It is non-toxic, inert, inexpensive, easily available, odorless and tasteless. Carbon dioxide is an appropriate SFE solvent for biological materials like rice bran, because of the possible thermal degradation of important minor components at higher temperature. (Rizvi, 1994; Chester et al., 1998; Clifford, 1999; Kiran et al., 2000; Mukhopadhyay, 2000; William and Clifford 2000).

Supercritical fluid extraction from food, pharmaceutical, nutraceutical and other natural and biological products have received significant attention. Several recent detailed studies, reviews and books reported the supercritical fluid extraction of various biological, food and natural products (Chen and Ling, 2000; King, 2000; Mukhopadhyay, 2000; Rozzi and Singh, 2000; Lang and Wai, 2001; Pop and Barth, 2001; Senorans et al., 2001; Wong et al., 2001; Canela et al., 2002; Danaher and O'Keefe, 2002; Mohamed and Mansoori , 2002; Raventos et al.,2002; Rozzi et al.,2002; Prieto et al., 2003). Lipids are an important part of the food system. Some of the recent studies relating to application of supercritical fluid for lipid include extraction from lavender (Reverchon and Porta., 1995), ginger oil (Roy et al.,1996), Turkish mint plant leaves (Ozer et al.,1996), corn (Moreau et al.,1996, soybean (Montanari et al.,1996), spearmint

oil from mint plant leaves (Ozer et al., 1996), cloudberry seed oil (Manninen et al., 1997), sunflower oil (Perrut et al., 1997), almond oil (Marroene et al., 1998), pistachio nuts lipids (Palazoglu and Balaban, 1998), rape seed, sunflower and soybean (Bjergegaard et al., 1999), corn bran (Taylor and King, 2000), grape seed oil (Lee et al., 2000), hiprose seed oil (Revercon et al., 2000), lavender essential oils and waxes (Akgun et al., 2000), Romanian mentha hybrids oil (Eugenia and Danielle, 2001).

Rice bran lipid extraction with supercritical fluid is also reported. Zhao et al. (1987) studied fractional extraction of rice bran oil at 40 °C and obtained oil yield in the range of 18.6 – 22.0 % with pressures variation from 14.7 – 34.3 MPa. Fractions obtained with SFE contained 8.8 % free fatty acids compared to 11.9 % for hexane-extracted oil. Ramsey (1991) compared rice bran oil extraction with hexane, SFE (29.99 MPa, 35 °C, 5 hr, 20.5 g/min) and SFE with co-solvent (29.99 MPa, 35 °C, 5 hr, 20.5 g/min, 5 % ethanol) extraction processes. He was able to recover 20.21%, 17.98% and 18.23 % oil yield and sterol yields were 9.35, 7.25 and 8.3 mg /g of rice bran for hexane, SFE and SFE–Co solvent extractions, respectively. Garcia et al. (1996) recovered 16-60 % of solvent extractable oil yield from rice bran at 28 MPa and 70 °C. Kuk and Dowd (1998) reported 19.2-20.4 % RBO yield in SFE extraction (48.26 - 62.05 MPa) compared to 20.5 % in hexane extraction. Xu and Godber (2000) compared solvent extraction (50% hexane and 50 % isopropanol v/v) of rice bran with supercritical carbon dioxide extraction (50 °C and 68.9 MPa) for γ -oryzanol fractionation. Their study suggested that SFE extracts up to four-times greater γ -oryzanol (5.39 mg/g of rice bran) compared to solvent extraction.

Dunford and King (2000) studied enrichment of rice bran oil (20.5 – 32.0 Mpa and 45 to 80 °C) to reduce FFA and minimize loss of phytosterols and found that low pressure and high temperature combinations are better for reducing loss of triglycerides and phytosterols during removal of FFA from crude rice bran oil. Badal (2002) in their rice bran lipid study with

supercritical carbon dioxide (40°C, 27.58 MPa) found that oil yield was the function of particle size during SFE. Their yield was 51.5% of the total ether extractable oil in 2 hours from small particle (16-48 mesh) compared to 41.2 % extracted from larger particle size (> 48 mesh) rice bran. In the present study supercritical extraction of rice bran lipids and antioxidant components were investigated at the pilot scale with use of carbon dioxide as a solvent.

3.2 Mathematical Modeling

The mass transfer rate of high initial concentration of extract (such as oil seeds) from a fixed bed containing natural material typically remains constant and then declines. Supercritical fluid extraction involves the control of solubility by manipulating temperature and pressures. Natural materials contain multiple components with solubilities and extractabilities that are difficult to predict (Lira, 1996). Different mathematical aspects related to SFE of lipids were described by King and List (1996) that include solubility, phase equilibria and mass transfer, fractionation and modeling. Because of the large number of mathematical variables and complexity of the equations involved in the modeling of supercritical extraction of lipids from the natural only the model used in this is described.

The Goto et al. (1993) model for extraction of essential oil from peppermint leaves was found applicable to the present study. Solute is assumed to be extracted after desorption from porous solid substrate of treated peppermint leaves. During the process diffusion occurred inside pores and the film surrounding the particle offers mass transfer resistance. This model was also applied to fatty acid and carotenoids extraction from microalgae *sprulina maxima* by Canela et al. (2002) and was used in the present study because of the similarity with experimental materials, extraction procedures and the experimental variables. In their application the mass of extract at bed outlet was described by the following equation

$$m(t) = \left[\frac{\varepsilon_p}{K} + (1 - \varepsilon_p) \right] \frac{\varepsilon_p}{K} + (1 - \varepsilon_p) X_0 \rho_s Q_{CO_2} A \tau \left\{ \frac{1}{a_1} \left[\exp\left(a_1 \frac{t}{\tau} \right) - 1 \right] + \frac{1}{a_2} \left[1 - \exp\left(a_2 \frac{t}{\tau} \right) \right] \right\} \quad (\text{eq 3.1})$$

Here,

A is a constant defined by the following equation

$$A = \frac{\phi}{[\varepsilon_p + (1 - \varepsilon_p)K](a_1 - a_2)} \left(\frac{1 - \varepsilon_1}{\varepsilon_1} \right) \quad (\text{eq3.2})$$

where,

$$a_1 = \frac{1}{2}(-b + \sqrt{b^2 - 4c}) \quad (\text{eq 3.3})$$

$$a_2 = \frac{1}{2}(-b - \sqrt{b^2 - 4c}) \quad (\text{eq 3.4})$$

$$b = \frac{\phi}{\varepsilon_p + (1 - \varepsilon_p)K} + \frac{1}{\varepsilon_1} + \frac{\phi(1 - \varepsilon_1)}{\varepsilon_1} \quad (\text{eq3.5})$$

$$c = \frac{\phi}{[\varepsilon_p + (1 - \varepsilon_p)K]\varepsilon_1} \quad (\text{eq 3.6})$$

$$\text{and } \phi = K_p A_p \tau \quad (\text{eq 3.7})$$

where, ε_1 =interstitial bed porosity

ε_p = particle porosity

K_p = combined mass transfer coefficient

A_p = specific surface area (1/L)

K = particle coefficient of the solvent in the solute

X_0 = intital solute mass ratio in the solid phase

ρ_s = solid true density (M/L³)

Q_{CO_2} = volumetric solvent flow rate (L³/T)

t = extraction time (T)

τ = CO₂ residence time (T)

3.3 Materials and Methods

Stabilized rice bran (Producers rice mill, Stuttgart, Arkansas) was sieved (4 mesh -1.18 mm) and stored in a freezer at $-16\text{ }^{\circ}\text{C}$. The initial moisture content of the bran was 3.8 % (w.b.). The pilot-scale supercritical fluid extractor (from Thar Technologies, Pittsburgh, PA) (Figure 3.3.1 and 3.3.2) had a capacity of 3 L and could operate at maximum pressure of 68.95 MPa. Before extraction, rice bran (750g) samples were thoroughly mixed with glass beads (3 mm, 1100g) to facilitate uniform distribution of carbon dioxide and to prevent channeling.

3.3.1 Supercritical Fluid Extraction

Extraction experiments were carried out for rice bran (750g) at different extraction pressures (27.58, 41.37 and 55.16 MPa) and temperatures (40 and 60 $^{\circ}\text{C}$). The flow of supercritical carbon dioxide through the extraction vessel was also varied (25, 45 and 65 g/min). Resulting extracts were collected at time intervals of 30, 60, 90, 120, 180 and 240 min from the cyclone collectors in pre-weighed glass vials. The duration of each extraction run was four hours and each experiment was duplicated. The oil samples extracted were weighed and cumulative weights were calculated by cumulatively adding the weight of oil collected during each extraction run. Extraction rates were calculated in terms of g of oil recovered per minute.

3.3.2 High Pressure Liquid Chromatography

The collected samples were analyzed with normal phase high-pressure liquid chromatography (HPLC). Chromatography system consisted of WatersTM (Milford, Ma) 510 HPLC pump, a 717 plus injector, a 470 scanning fluorescence detector (excitation at 290 nm and emission at 330 nm) and 486 absorbance detector (UV) (330 nm). A SupelcosilTM (Supelco, Bellefonte, PA) LC-Si, 5 μm , 25cm X4.6 mm i.d. column with hexane: ethyl acetate: acetic acid(98.4:0.8:0.8) mobile phase, flow rate of 1.9 ml/min was used for chromatographic separation of oryzanol, tocopherols



Figure 3.3.1 Pilot scale supercritical fluid extractor used for the experiments

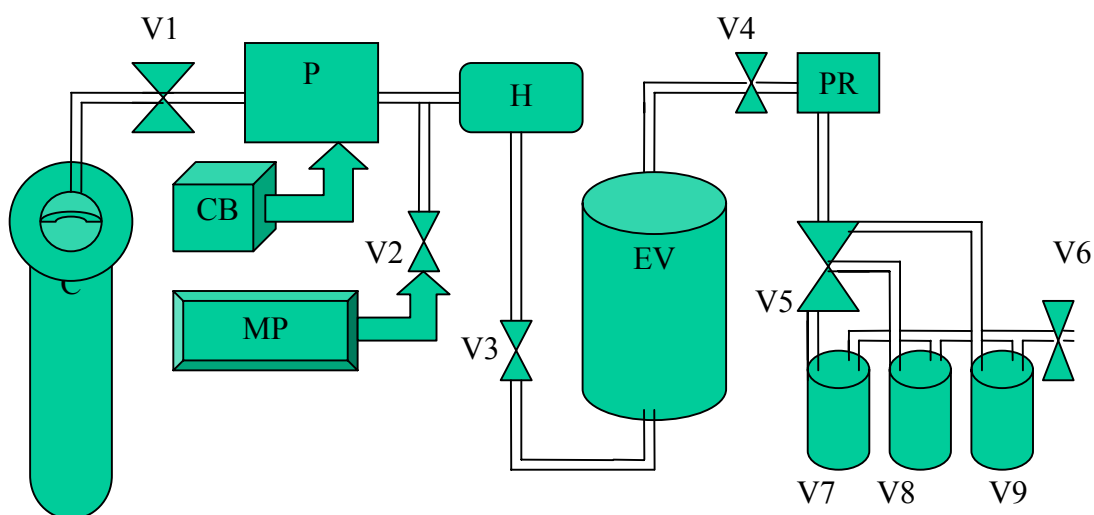

Figure 3.3.2 Flow diagram of the supercritical fluid extraction system used for the experiments. C- CO₂ cylinder, CB- cooling bath, P- pressure pump, MP- modifier pump, H- heater, EV- extraction vessel, PR- pressure regulator, V -valve

and tocotrienols. The chromatogram (see Figure 3.3.3 as example) from samples were analyzed by external standard method.

3.3.3 Soxhlet Extraction

Extraction of rice bran lipids with conventional solvent extraction method was also carried out by applying AOAC method (Aa- 4-38) with use of a Soxhlet apparatus (Kimax) and electric heater (Electrothermal) using petroleum ether. Rice bran samples (20 gm) were placed in the cellulose extraction thimble (WhatmanTM 30 X 77) and 200 ml of solvent (petroleum ether) was filled in the boiling flask, and was heated to change the solvent to a gaseous phase. The solvent in gaseous form passed through rice bran in the thimble that was liquefied by cooling the solvent vapor by a water-cooled condenser. Each Soxhlet extraction experiment was continued for 6-hour time interval and duplicated. At the end of the extraction solvent was evaporated by heating in a conventional water bath with application of nitrogen. The oil percentage in rice bran was calculated. Solvent-extracted samples of rice lipids were also analyzed for concentration of antioxidant compounds using normal-phase HPLC techniques described earlier.

3.4 Results and Discussions

The experimental data for extract yields and antioxidant were used to calculate the total yield and cumulative yield with the time.

3.4.1 Total Oil Yield

The solvent extraction of the experimental rice bran with petroleum ether for 6-hours in two replications gave oil yielded an average of 17.8 % with petroleum ether extractions. Several samples were extracted for time up to 10 hours under same conditions and yielded same extraction yields. There fore, 17.8 % oil yield was taken as the maximum ether-extractable oil. A 20 gm sample from rice bran recovered after SFE experiments was again extracted with 6-hour

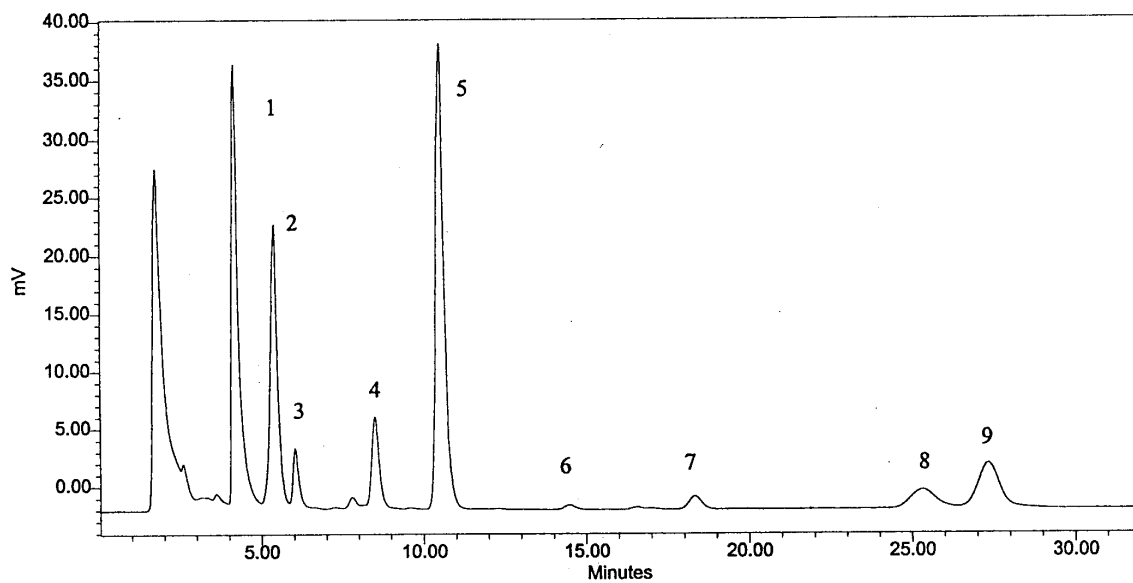

1 -- α -tocopherol; 2 -- α -tocotrienol; 3 -- β -tocopherol; 4 -- γ -tocopherol; 5 -- γ -tocotrienol; 6 -- δ -tocopherol; 7 -- δ -tocotrienol; 8,9 -- γ -oryzanol.

Figure 3.3.3 Normal phase chromatogram for tocopherol, tocotrienol and oryzanol

solvent extraction for determination of the residual oil after supercritical extractions. The bar diagram were plotted by combining these results.

Total oil yield from SFE extraction (for 4 hour) was very low which increased significantly ($p < 0.05$) with increase in pressure. Figure 3.4.1.1 shows total oil yield at different pressures. At 60 °C and 45 g/min, SFE oil yield was 30.2 % of solvent (petroleum ether) extractable (40.48 g total) oil yield at 27.6 MPa (4000 psi) and increased to 76.3% (102.23 g) at 55.2 MPa (8000 psi). Similar trends were shown by Garcia et al. (1996) where 16-60% hexane extractable oil yield at pressure range of 10-28 MPa (temperature 70 °C) and their experiments also indicated increase in oil yield with pressure. This increase in yield may be explained by the increase in density of carbon dioxide with pressure. With increase in pressure solubility of the oil constituents increases (Reverchon et al., 2000). Maximum oil extracted at 55.1 MPa and 60 °C was 96.7 % of hexane extractable oil in four hour SFE extraction.

There was significant ($p < 0.05$) increase in total oil yield with flow also. Figure 3.4.1.2 shows the effect of flow at 41.4 MPa and 40 °C. Increase in flow from 25 g/min to 65 g/min the total oil yield increased from 38.6 % (51.72 g) to 91.3% (122.27 g) of solvent extractable oil. This increase in extract yield may be attributed to the increased mass transfer rate at higher flow rates. This trend indicates that convective mass transfer may be dominant force compare to intraparticle diffusion resistance.

Temperature effect on total oil yield was opposite to the pressure and flow effects. The lower temperature resulted in higher oil extraction. Temperature effect on total oil yield was not found statistically significant. Figure 3.4.1.3 shows the temperature effect at 55.2 MPa for different flow rates. As we can see for all flow rates quantitative extraction of oil decreased with the rise in temperature possibly due to lower solvent density at higher temperature. Similar results were reported by Garcia et al. (1996) in their experiments at 28 MPa and temperatures of

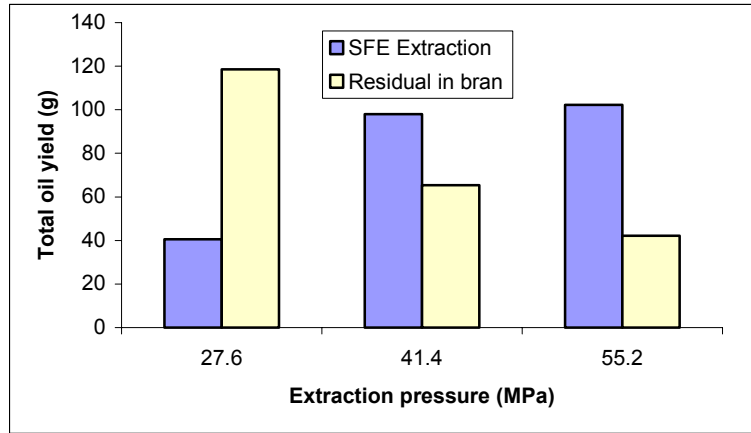

Figure 3.4.1.1 Total oil yield as affected by pressure (F=45 g/min, T=60 °C)

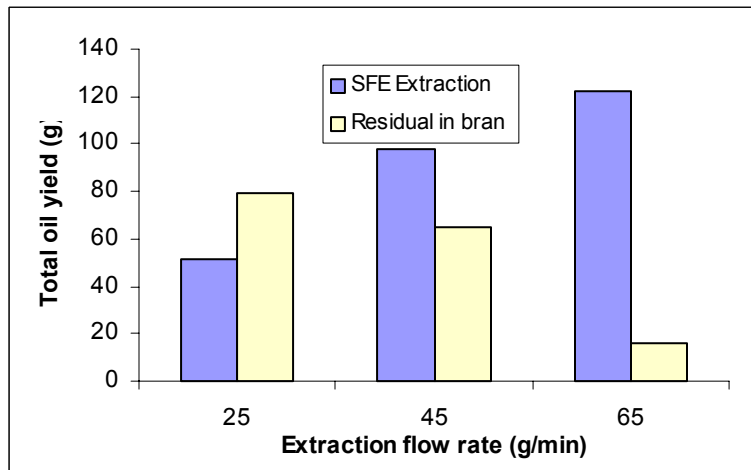

Figure 3.4.1.2 Total oil yield as affected by flow (P=41.4 MPa, T=40 °C)

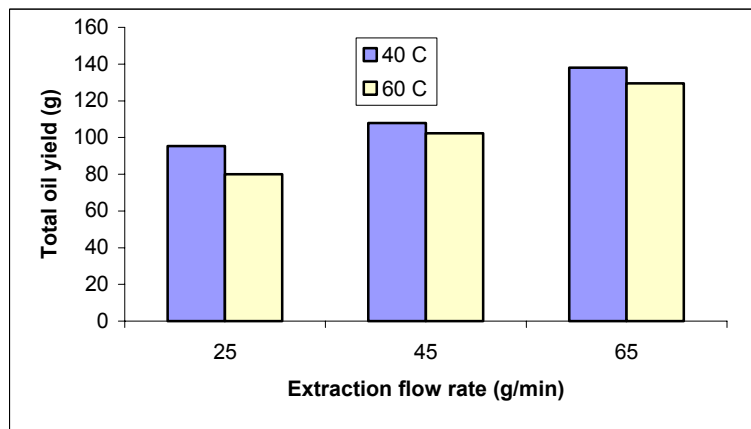

Figure 3.4.1.3 Total oil yield as affected by temperature (P=55.2 MPa)

40-50 °C. But they also observed opposite trend at higher temperature ranges (50 –70 °C). Shen et al. (1996) also observed higher extract yield at 60 °C compared to 40 °C in their experiments at 24 MPa with rice bran.

3.4.2 Cumulative Extraction and Extraction Rates

Total extract yield data may not be sufficient to represent the extraction process completely. Hence, experiments were designed to collect the extract samples at various time intervals (30, 60, 90, 120, 180 and 240 min) during a given four-hour extraction run. These extract yield data collected along the extraction process were used to calculate cumulative extract yield up to a particular extraction time and the extraction rates for particular time interval (by dividing mass of the extract with duration of collection). These data were also used for understanding and characterizing extraction process by appropriate graphical representations and statistical calculations.

The extract yields were significantly ($p < 0.05$) increased with increase in extraction pressures from 27.6 to 55.2 MPa as shown in Figure 3.4.2.1 at 40 °C. Similar increase in yield with pressure are reported by Shen et al. (1996) at 17, 24 and 31 MPa, Garcia et al. (1996) at 10, 16.5 and 28.0 MPa, and Kim et al. (1999) at 20.68 to 41.37 MPa. Increase in pressure of supercritical fluid at constant temperature leads to increase in density of the carbon dioxide and there by increase its solvating strength. At 65 g/min extraction curve converts from linearly increasing with time at low pressure to logarithmic type at higher pressure, indicating stabilization at some later point at higher pressures. This indicates that at higher flow rates since initially extractions are high, at later stage of extraction diffusion resistance through the rice bran particle plays major role.

Oil extraction process was also significantly ($p < 0.05$) affected by flow rate of supercritical carbon dioxide. As shown in Figure 3.4.2.2 an increase in flow from 25 g/min to

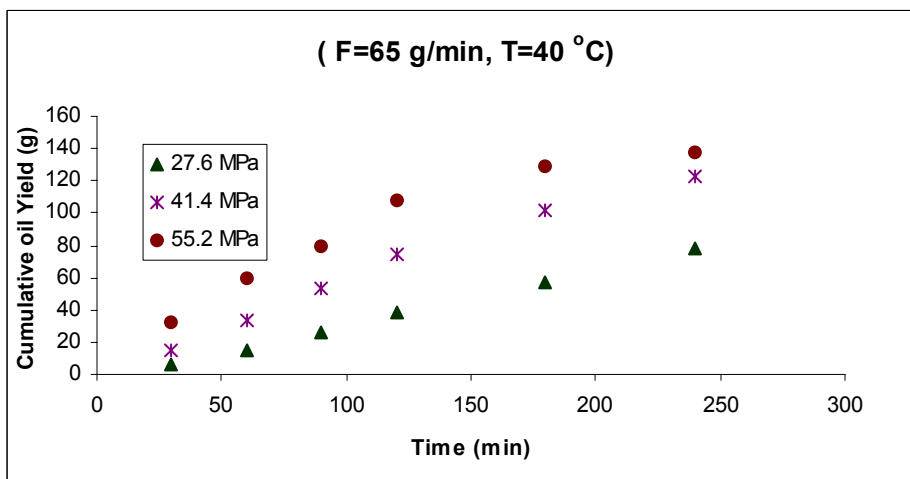
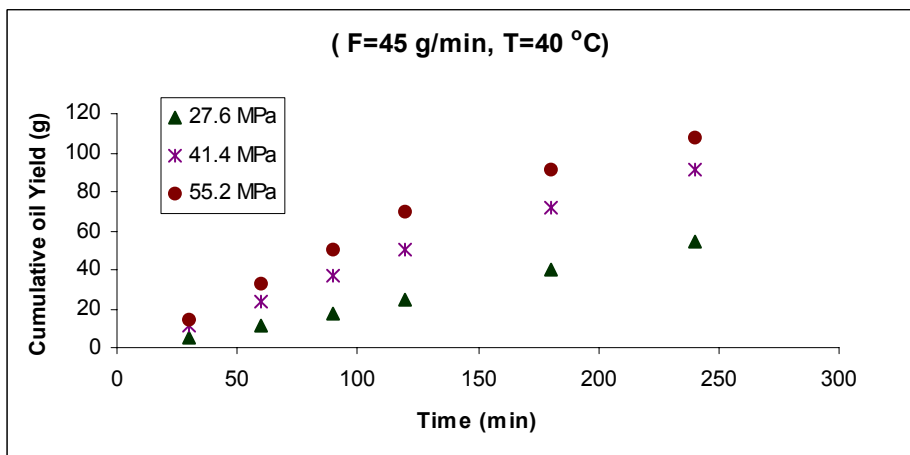
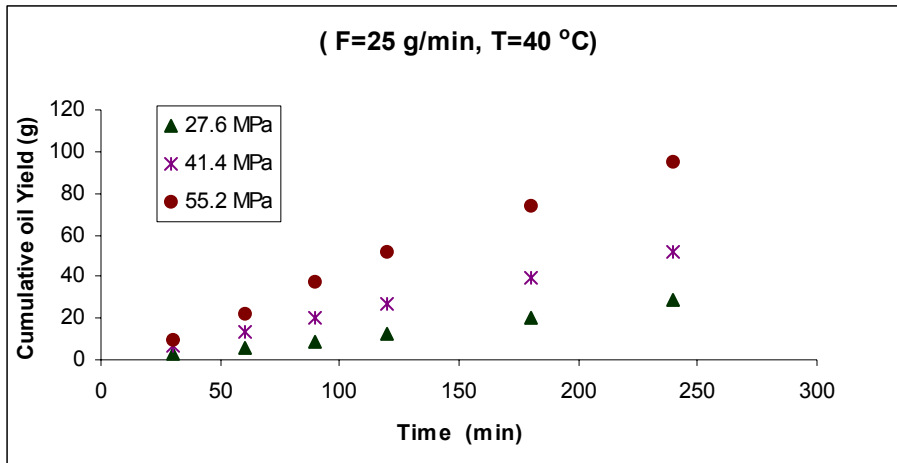

Figure 3. 4 .2.1 Cumulative extract yield as affected by pressure at 40 °C with respect to flow rate(F)

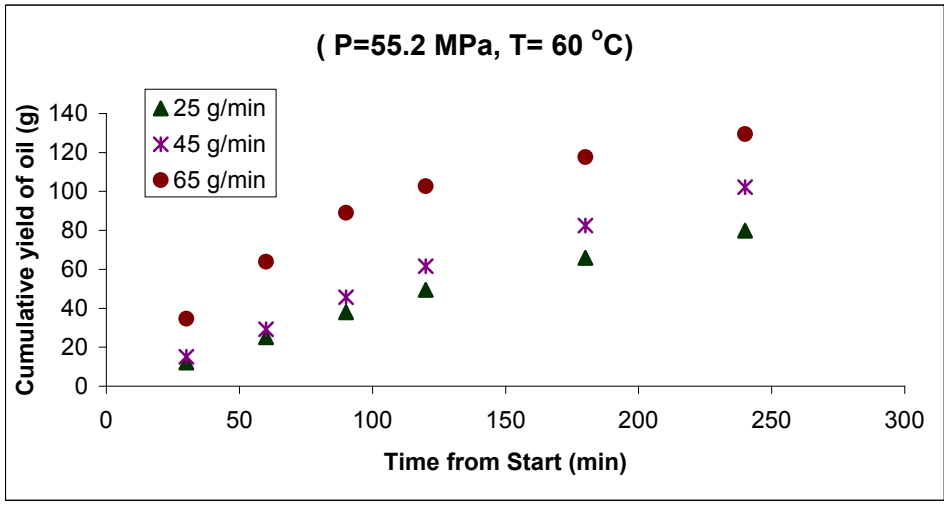
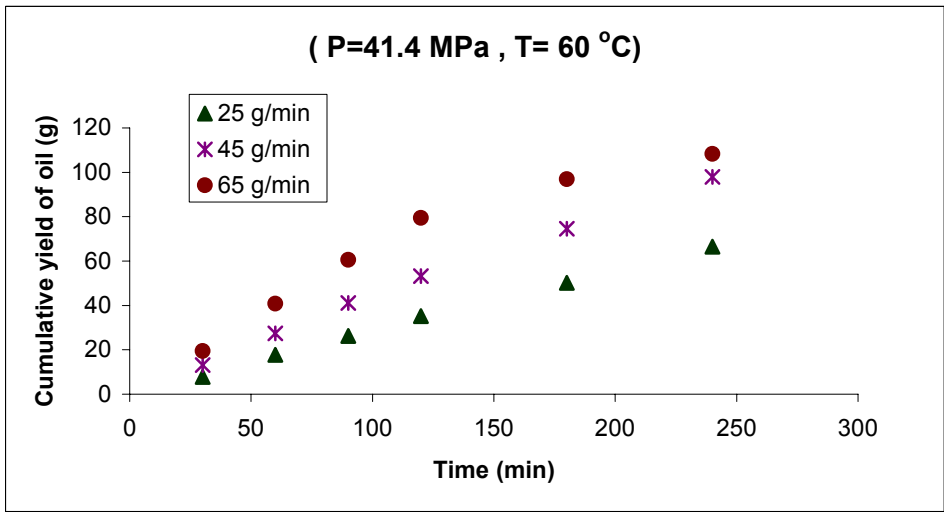
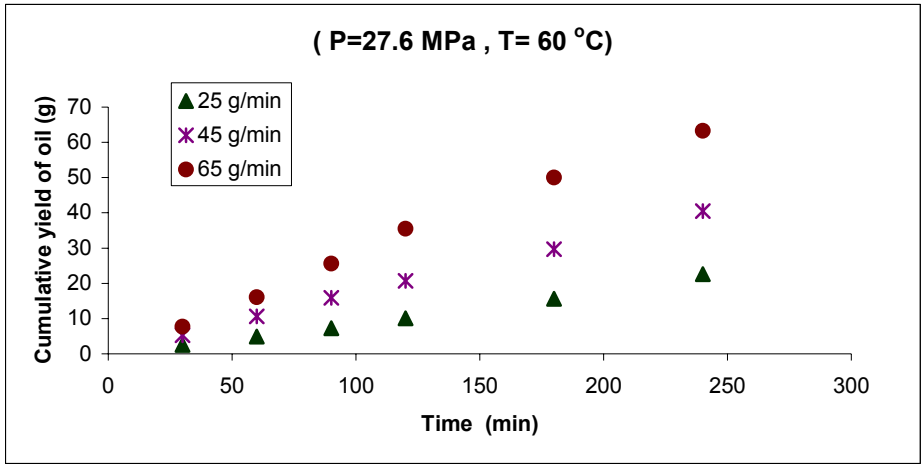

Figure 3.4.2.2 Cumulative extract yield as affected by flow at 60 °C with respect to pressure (P)

65 g/min enhanced oil extraction. The 65g/min flow rate at 55.2 MPa yielded the highest of 129.5 g per 750 g rice bran loaded in the batch cell. Reverchon et al. (2000) also reported increase in oil yield from hiprose seed with increase in flow rate of carbon dioxide from 1 g/min to 6 g/min. At low flow rates mass transfer between carbon dioxide and oil from bran is limiting and results in a linear relationship. At higher flow rates convective mass transfer is generally not limiting but the diffusion resistance from center to the surface of the bran becomes the primary limiting factor.

Temperature effect on the extraction process was opposite to the pressure and flow effect. Figure 3.4.2.3 indicates higher extraction at 40 °C compared to 60 °C, but this temperature effect was not found statistically significant ($p>0.05$) for each extraction time. Xu and Godber (2000) observed increase in extract yield with increase in temperature from 30 ° to 60 °C, but they also observed that yield does not increase further with increase in temperature to 75 °C. Shen et al. (1996) also observed higher extract yield at 60 °C compared to 40 °C in their experiments at 24 MPa with rice bran. On the other hand Garcia et al. (1996) reported higher yield at 40 compared to 50 °C. Tasuda et al. (1995) also reported higher extract yield at lower temperature in the case of their tamarind extraction studies. Based on those results temperature effect varied widely depending on other extraction conditions including batch size and other variables. Turner et al. (2001) reported that effect of temperature on the solvent strength depends on corresponding pressure of carbon dioxide in the supercritical region. Below “crossover point” increase in temperature results in lowers solvent strength with lower density where as above “ cross over point” increase in temperature may increase solvent strength in spite of reduced density because of increased vapor pressure of analyte.

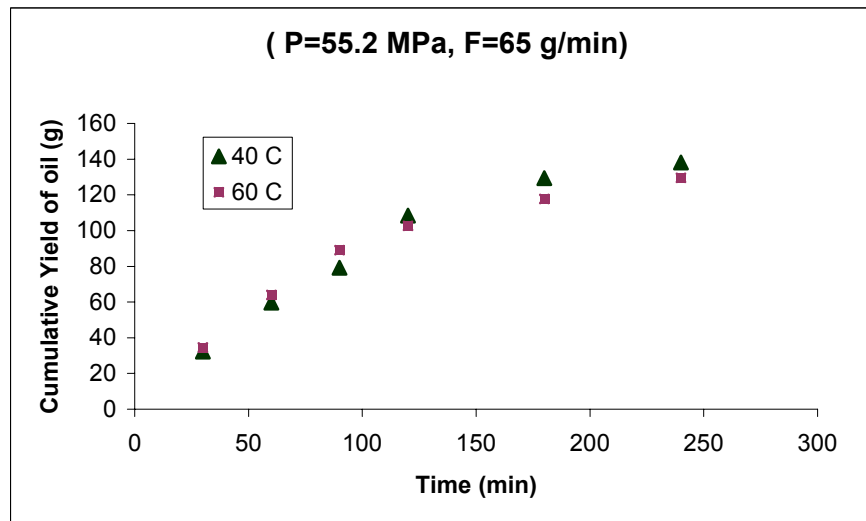
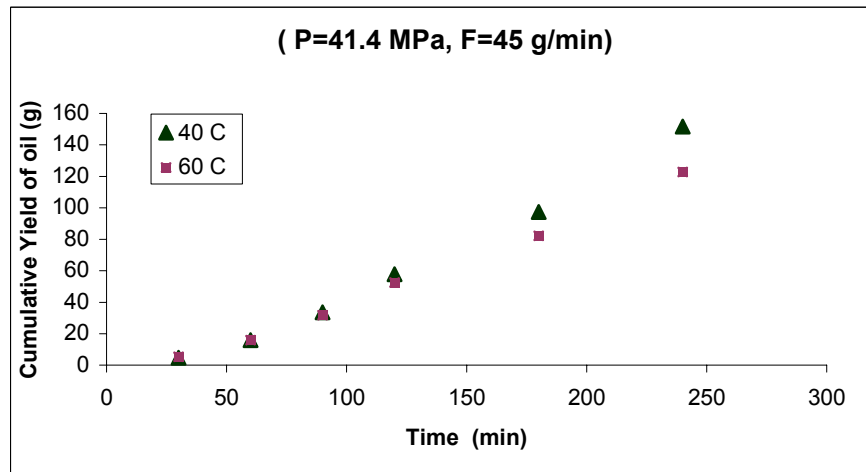
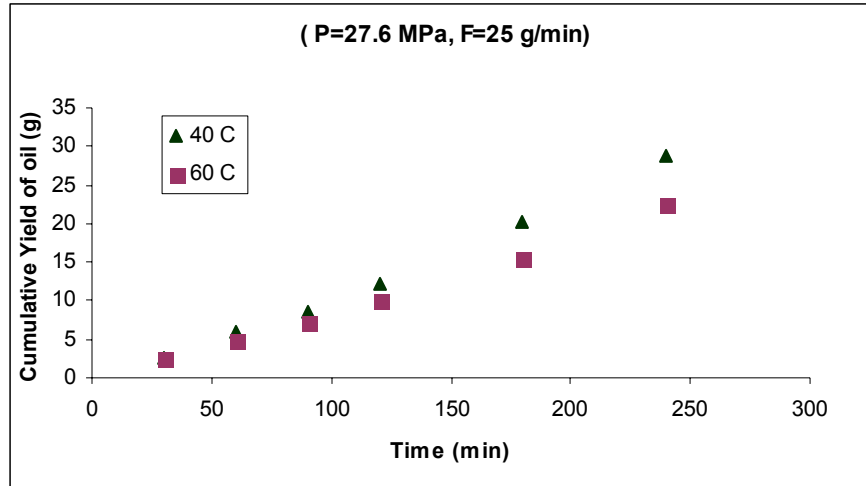

Figure 3.4.2.3 Cumulative extract yield as affected by temperature

3.4.3 Antioxidants in Rice Bran Oil

Normal phase high-pressure liquid chromatography analysis of extracts gave data for concentration of antioxidant compounds of oryzanol, tocopherols and tocotrienols. These results of HPLC analysis were used to describe the effect of extraction condition of supercritical carbon dioxide on concentration and extraction yields of these nutritionally important components of rice bran oil.

Pressure was also found to have positive effect on these antioxidants and pressure effect was statistically significant for Oryzanol, tocopherols and tocotrienols ($p < 0.05$). As shown in figure 3.4.3.1 concentration of the antioxidants compounds increased with pressure of supercritical carbon dioxide. Shen et al. (1996) in their SFE experiments with rice bran got increased yield of oryzanol with increase in pressure from 17 to 31 MPa at 40 °C. Higher solvent density at higher pressure may be responsible for increased solubility and hence extraction of antioxidant compounds at higher pressures. Cheung et al. (1998) also reported increased extraction of ω -3 fatty acids with increase of pressure from 24.1 MPa to 37.9 MPa.

Flow effect on antioxidants in rice bran oil was not as clear as pressure effect and was not statistically significant for antioxidants ($p > 0.05$). Figure 3.4.3.2 showing the concentration of antioxidants compound also indicates that flow effect varied with different antioxidants as well as with extraction conditions. Though results does not gives statistically significant difference in antioxidants due to flow rate, Figure 3.4.3.2 shows trends towards increased antioxidant extraction with increase in flow rate of the supercritical carbon dioxide. This trends may be due to slight variation in the solubility of antioxidant compounds with different flow rates.

Temperature did not significantly affect antioxidants extraction ($p > 0.05$). Figure 3.4.3.3 give temperature effect on antioxidants concentration. Xu and Godber (2000) found variations in

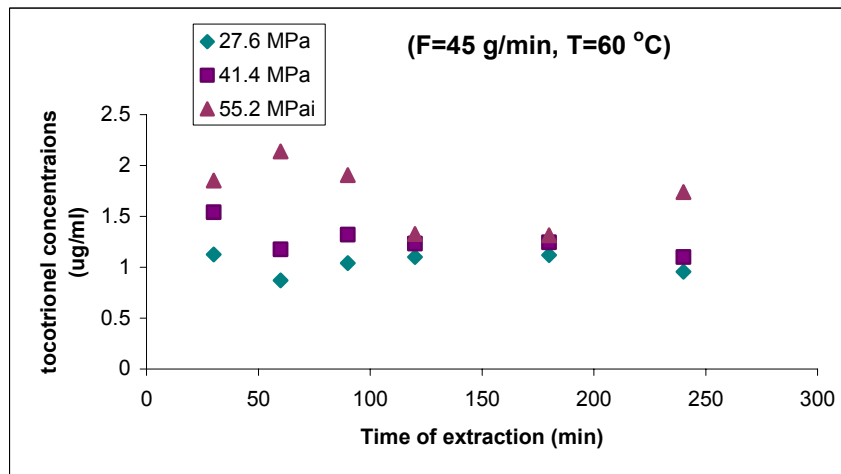
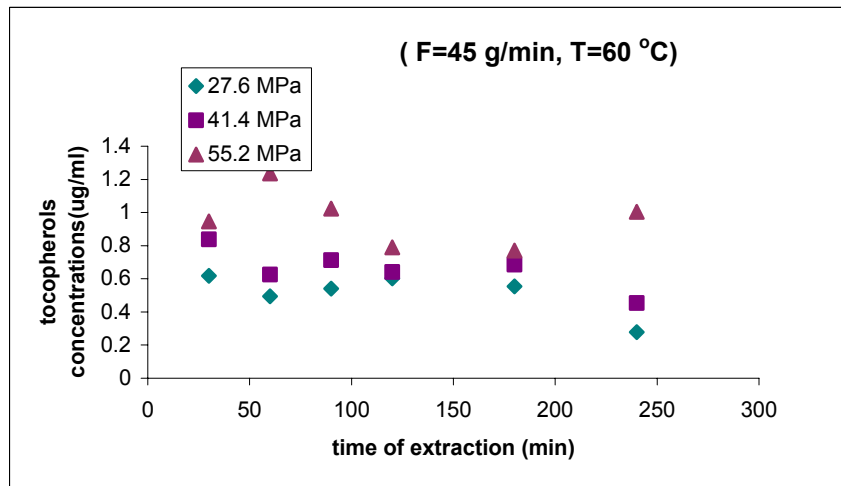
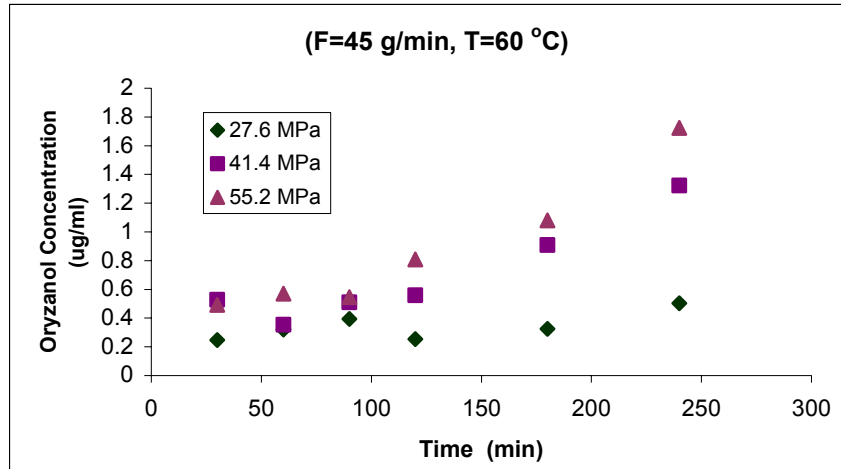

Figure 3.4.3.1 Effect of pressure on concentration of antioxidants

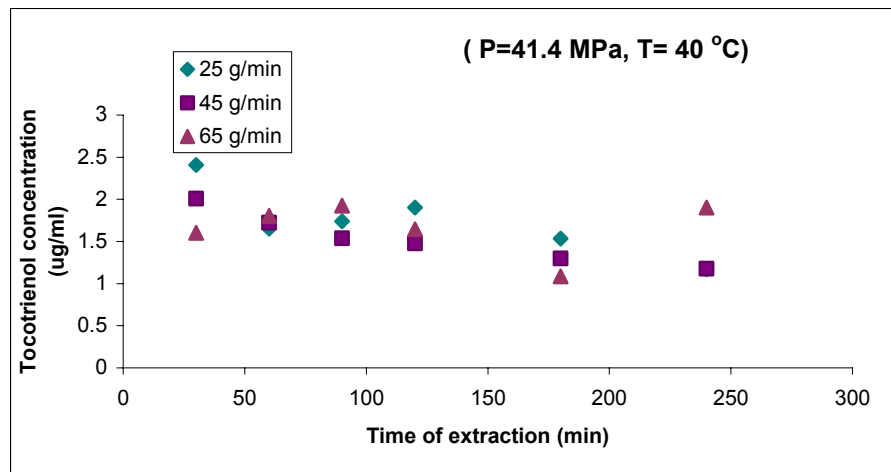
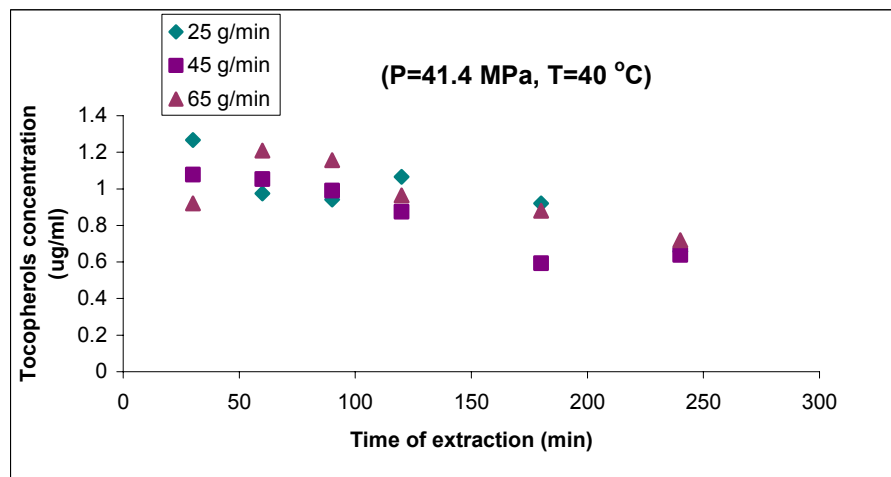
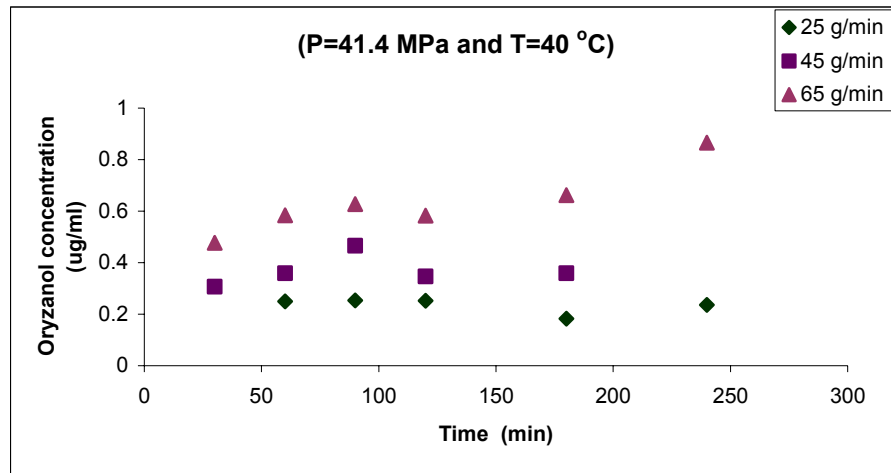

Figure 3.4.3.2 Effect of flow on concentration of antioxidants

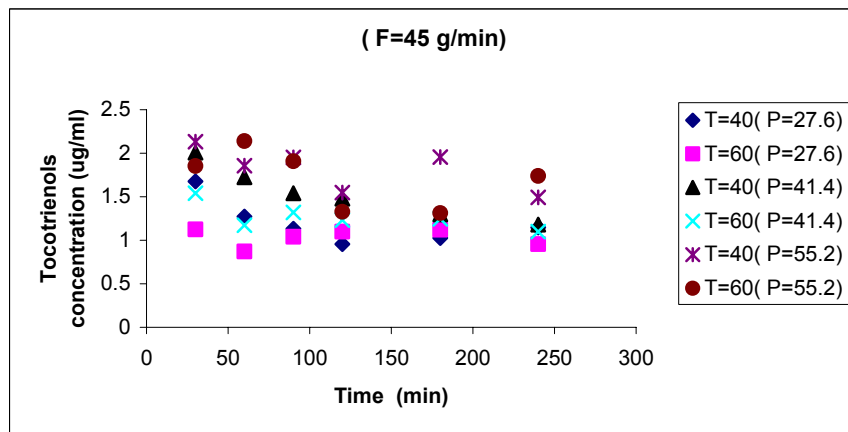
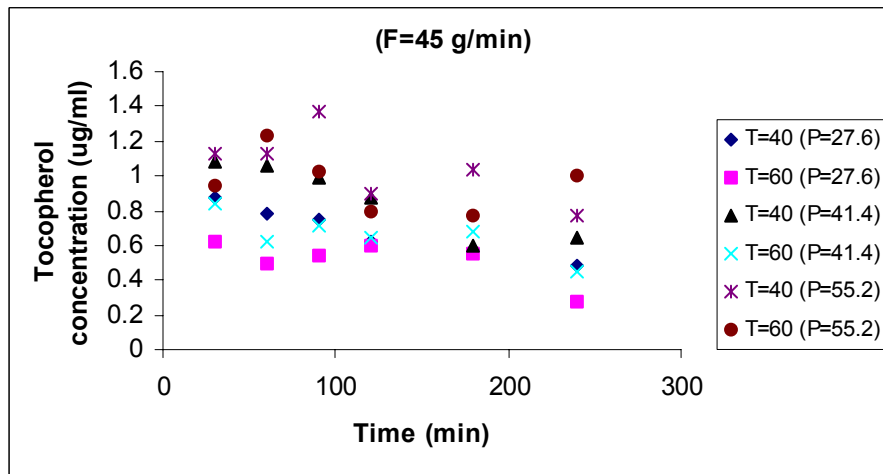
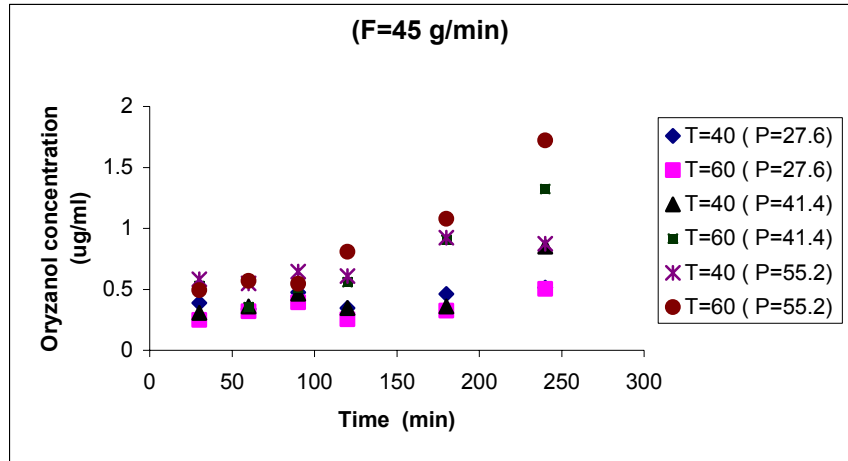

Figure 3.4.3.3 Effect of temperature on concentration of antioxidants

the temperature effect on concentrations of oryzanols from rice bran depending on time of extractions. For 10 min extraction γ -oryzanol extraction was significantly higher at higher temperature (55, 60, 75 °C) compared to lower temperatures (30, 40, 45, 50 °C), but concentration of γ -oryzanol at 60 and 75 °C for 20 min extract was significantly lower than that at 50 °C. Shen et al. (1996) found increased α -tocopherol extraction of rice bran oils with temperature with their extractions at 24 MPa and 20, 40 and 60 °C however they obtained lower oryzanol concentrations at higher temperatures, which supports varying behavior with type of antioxidants. These variations with antioxidant compounds may be due to their differences in chemical structure and size of the molecules.

3.4.4 Comparing Solvent and Supercritical Extractions

Conventional methods of rice bran lipid extraction utilize solvents such as hexane and ethers. Petroleum ether extractions using the Soxhlet method were compared with supercritical fluid extraction in terms of oil yields and antioxidant extraction. As evident from Figure 3.4.4.1 when supercritical extraction was carried out at higher pressure (55.2 MPa) and flow rate (65 g/min) of carbon dioxide, resultant extract yields were comparable with that of solvent extraction. But at low pressure and flow rates SFE extractions yields were poor compared to petroleum ether extractions. This means that solvent strength of carbon dioxide at higher pressure and flow rate was good enough to replace petroleum ether for extraction. Shen et al. (1996) obtained 96.8% of the hexane extractable oil yield with SFE of rice bran at 31 MPa, 40 °C and flow rate of 2.5 kg/hr (41.7 g/min) flow rate in 6 hours extraction. On other hand Garcia et al. (1996) obtained 16-61 % rice bran oil yields at 28 MPa and 40-70 °C. One advantage of SFE over solvent extraction is the selective extraction and fractionation of desired compounds by altering density. So extraction of antioxidant compounds with SFE extraction was compared with that of solvent extraction. Figure 3.4.4.2 shows the results of minor antioxidant components to

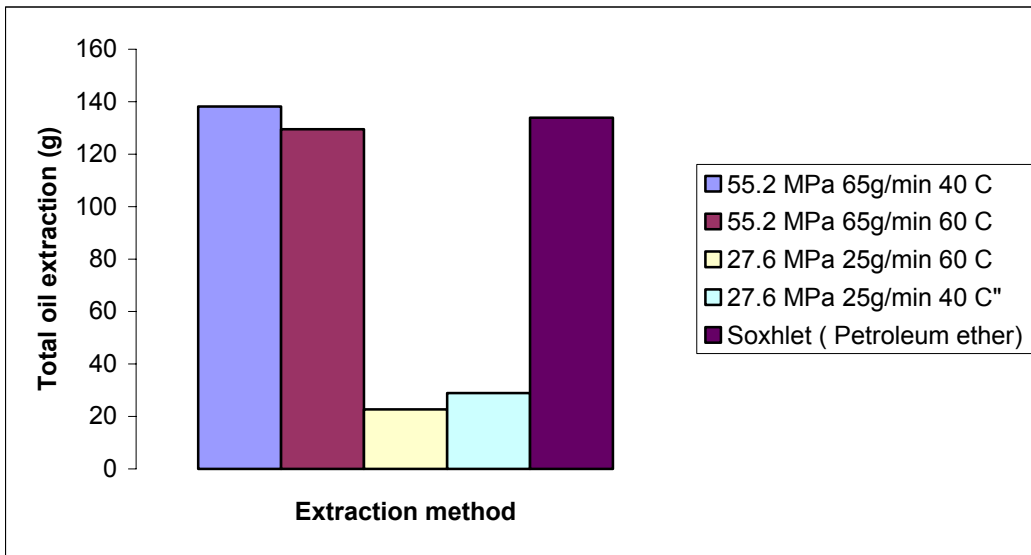

Figure 3.4.4.1 Comparison extraction yields for maximum and minimum of total yield in SFE after 4 hour compared to and petroleum ether extraction for 6 hours

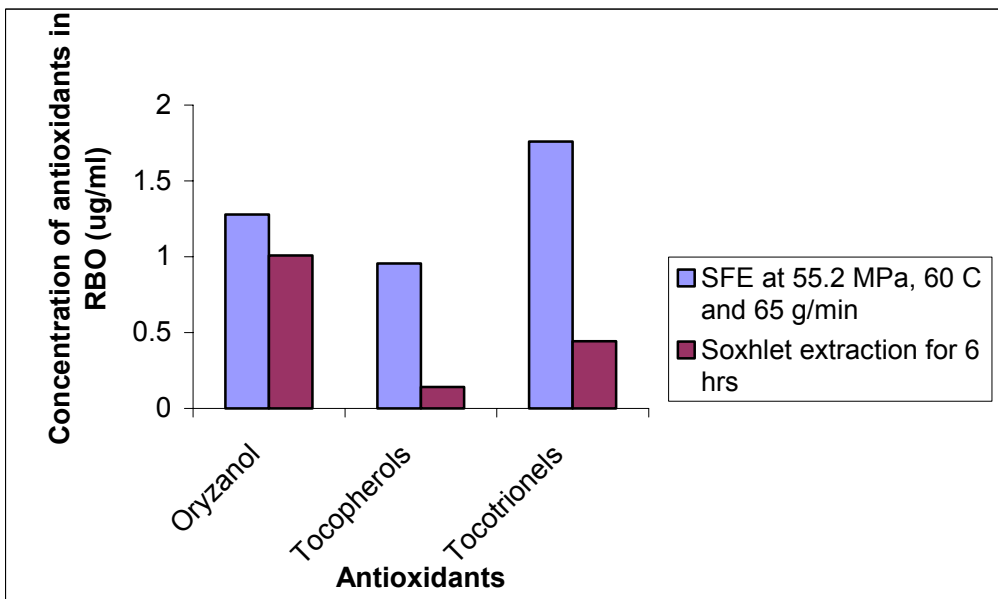

Figure 3.4.4.2 Antioxidant yields for SFE for 4 hours compared to petroleum ether extraction for 6 hours

determine if fractionation occurred. As evident from this figure the supercritical extract obtained at 55.2 MPa and 60 °C with 65 g/min flow rate of carbon dioxide showed much higher concentrations of oryzanol, tocopherols and tocotrienols when compared to petroleum ether extract. Similar results are also reported by Xu and Godber (2000) for extraction of γ -oryzanol from rice bran.

3.4.5 Modeling Results for The Extraction Process

The Goto et al. (1996) model for supercritical fluid extraction from porous biological material in the form similar to that applied by Canela et al. (2002) in their SFE study related to microalgae was applied to the present study. Properties of rice bran such as surface area, particle size, different densities etc. were measured or obtained from the available literature to apply to the model. The average particle size and surface area were measured at the materials lab of CAMD–LSU. Details of the obtained property data are shown in Table 3.4.5.1 Constants for the model such as a_1 , a_2 , b , c and A were calculated by using appropriate property data with the equations given in Section 3.2 for each experimental operating conditions(P , F , T) and were placed in the mass equation (3.1) to calculate predicted mass of the extract.

The mass of extract predicted with model was compared with that of actual extract yield values obtained during the experiment. The values of coefficients K and K_p in these equations were varied to obtain the least square difference between the experimental and predicted values. The value of coefficients K and K_p were optimized in such a way by least square method till we get the best fit of the model with experimental values. This procedure was repeated for each set of extraction conditions and K and K_p values were obtained. Table 3.4.5.2 shows the values of partition coefficient K and mass transfer coefficient K_p for the respective experimental conditions. Figure 3.4.5.1 shows the comparison between experimental and fitted lines for the different extraction conditions. From these curves of experimental value and predicted value

Table 3.4.5.1 Property data obtained for the modeling of extraction process

Parameter	Symbol	Equation for calculation	Value of the parameter
Bed density	ρ_a	Literature value	1048 kg/m ³
Particle density	ρ_p	Literature value	865.3 kg/m ³
True density	ρ_s	Literature value	1220 kg/m ³
Initial solute mass ratio in the solid phase	X_0	Measured value	0.18
Specific surface area	a_p	Measured value	1.7
Particle porosity	ε_p	$1 - \rho_p/\rho_s$	0.299
Total bed porosity	ε	$1 - \rho_a/\rho_s$	0.14
Interstitial bed porosity	ε_1	$1 - \rho_a/\rho_s$	0.174
Residence time for CO ₂	τ	$\varepsilon V_c / Q_{CO_2}$	Varied with flow rate

Table 3.4.5.2 Values of partition co-efficient (K) and mass transfer coefficient (Kp) predicted using Goto model

Flow g/min	Temp °C	Pressure MPa	K	K _p	r ²	K _p a _p x 100	K X 100
25	40	27.58	0.033	0.009	0.95	1.530	3.29
		41.37	0.023	0.010	0.98	1.700	2.30
		55.16	0.021	0.011	0.96	1.921	2.10
	60	27.58	0.039	0.011	0.94	1.870	3.95
		41.37	0.022	0.013	0.97	2.125	2.18
		55.16	0.019	0.012	0.99	2.074	1.86
45	40	27.58	0.024	0.010	0.96	1.717	2.40
		41.37	0.018	0.011	0.98	1.921	1.80
		55.16	0.016	0.012	0.99	2.006	1.60
	60	27.58	0.029	0.013	0.96	2.159	2.93
		41.37	0.018	0.014	0.97	2.312	1.84
		55.16	0.017	0.012	0.99	2.057	1.69
65	40	27.58	0.019	0.010	0.97	1.700	1.94
		41.37	0.014	0.010	0.99	1.700	1.44
		55.16	0.016	0.012	0.98	2.040	1.60
	60	27.58	0.022	0.012	0.98	2.040	2.24
		41.37	0.016	0.014	0.99	2.295	1.60
		55.16	0.014	0.013	0.97	2.125	1.36

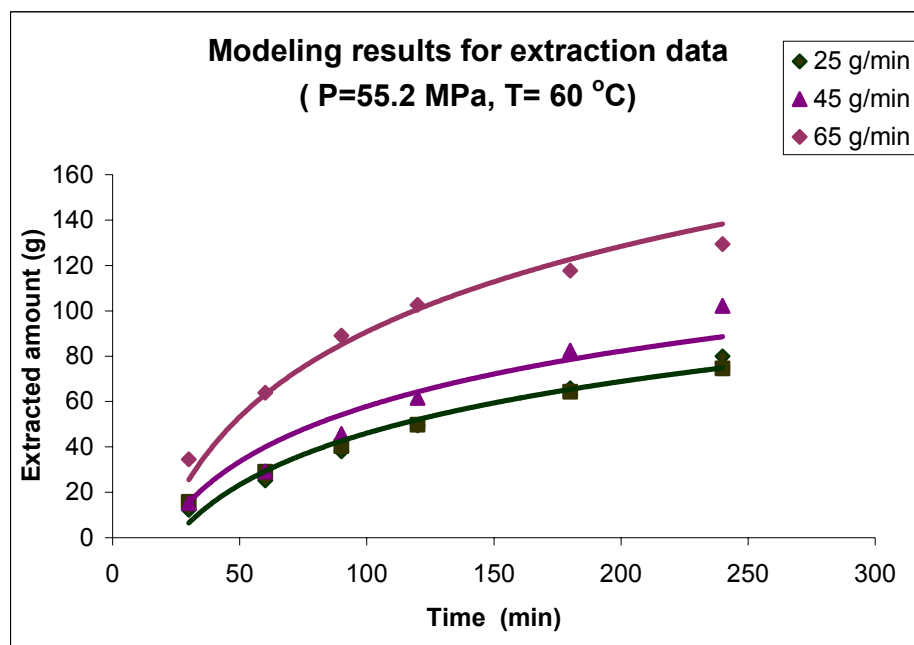

Figure 3.4.5.1 Comparing model and experimental values for extraction

with model and from the data given in Table 3.4.5.1, the Goto model was closely able to predict the extraction behavior of the rice bran total lipid extraction under the experimental conditions used in the present study.

Chapter-4

Supercritical Fluid Exaction and Adsorption Processes for Rice Bran Lipids with Use of Rice Hull Ash

4.1 Introduction

A nutritional benefit of rice bran oil, coupled with developments in stabilization techniques, has increased interest in rice bran. Rice bran oil has a high unsaponifiable level (4.2%), vitamin E (0.1-0.14%) and oryzanols (0.9-2.9%) (Kato et al., 1981; Sayre and Saunders, 1990; Hu, 1995; De Deckere and Korver, 1996; Orthoefer, 1996; Shin et al., 1997; Xu and Godber, 1999; Lloyd et al., 2000; Dunford, 2001). Vitamin E consists of tocopherols (α , β , γ and δ) and tocotrienols (α , β and γ). Vitamin E protects cell membranes by blocking the oxidation of the unsaturated fatty acids and acting as a scavenger of free radical (Komiyama et al., 1992; Nestaretnam et al., 1998). γ -Oryzanol reduces cholesterol absorption (Bourgeois, 1992; Orthoefer and Nicolosi, 1993; Hu, 1995; Rong et al., 1997).

Rice lipids (16-22 % of rice bran) are a by-product of the rice milling industry. Supercritical fluid extraction (SFE) is an emerging alternative extraction technique of conventional solvent extraction methods that use toxic and flammable solvents and create an environmental concern. SFE with carbon dioxide is a “green” extraction technique that has gained generally regarded as safe (GRAS) status and additionally has fractionation capability. Carbon dioxide ($P_c = 7.10$ MPa and $T_c = 31$ °C) is the most widely used supercritical solvent for biological, food and pharmaceutical materials (Rizvi, 1994; Chester et al., 1998; Clifford, 1999; Kiran et al., 2000; Mukhopadhyay, 2000; William and Clifford, 2000).

Recently, SFE from food, pharmaceutical, nutraceutical and other natural and biological products has received significant attention (Mukhopadhyay, 2000; Rozzi and Singh, 2000; Lang and Wai, 2001; Pop and Barth, 2001; Senorans et al., 2001; Wong et al., 2001; Mohamed and

Mansoori, 2002; Raventos et al., 2002; Rozzi et al., 2002; Prieto et al., 2003). Lipid extraction using supercritical fluids has been reported from many natural products (Reverchon and Porta., 1995, Roy et al., 1996, Ozer et al., 1996; Moreau et al., 1996; Montanari et al., 1996; Ozer et al., 1996; Manninen et al.; 1997; Perrut et al., 1997; Marroene et al., 1998; Palazoglu and Balaban, 1998; Bjerregaard et al., 1999; Taylor and King, 2000; Lee et al., 2000; Reverchon et al., 2000; Akgun et al., 2000; Eugenia and Danielle, 2001). Rice bran lipid extraction has also reported in recent literature (Zhao et al.; 1987; Ramsey, 1991; Garcia et al., 1996; Kuk and Dowd; Xu and Godber, 2000; Dunford and King, 2000; Badal, 2002)

The rice hull (husk), outer fibrous layer of the rice kernel, constitutes approximately 20 % of the weight of paddy. Over 510 million tons of rice production worldwide produces approximately 100 million tons of rice hulls available from rice mills. Increased energy cost has lead to increasing use of rice hulls as a renewable source for energy. Rice hull energy content at 14.0 % moisture content is 11.9 – 13.0 MJ/kg (5,116.5-5,589.4 Btu/lb). Use of hulls for energy in rice mills also eliminates high transportation costs for disposing this low bulk density by-product (Vellupillai et al., 1997). Rice hull ash (RHA) (16- 22 % of husk) is an end product of the rice husk energy generation system (IRRI, 2003). The cellulose of the rice hull is consumed in the burning process, which leaves silica-rich ash as an end product. Composition of rice hull ash depends on the conditions of pyro-processing (Vellupillai et al., 1997). Beagle (1978) has tabulated possible uses of RHA, but until recently it has been mostly used for production of cement. Due to its high silica content (>90%), RHA is an excellent potential medium for adsorption processes. Past studies relating to use of rice hull ash adsorbent are mainly concerned with the adsorption of components from oils and wastewater. These include adsorption of phospholipid (Brown and Snyder, 1989), lutein (Proctor and Pallanippan, 1990), palmitic and oleic acids (Ooi and Leong, 1991), carotene (Liew et al., 1993), lauric, myristic and stearic acids

(Idris and Farook, 1994), xanthophylls, lutein, phospholipid, free fatty acids (Proctor et al., 1995), myristic, palmitic and stearic acids (Huseyin and Yuksel, 1999), saturated fatty acids (Farook and Ravendran, 2000) and carotenoids (Jorge et al., 2000) from different lipid mediums. RHA has been used for basic blue dye adsorption from textile effluent (Ahmed and Ram, 1992), Hg (II) adsorption from aqueous solutions (Tiwari et al., 1995), protein adsorption (Jeyashoke et al., 1996), decolorization of raw sugar solutions (Ahmedna et al., 1997), purification of bacteriocins from freeze dried culture supernatants (Janes et al., 1998), and treatment of textile dyes (Sumanjit , 2001).

Past studies of supercritical extraction have indicated competitive quantitative extraction and higher quality extraction compared with conventional solvent extraction. More research efforts are needed for supercritical extraction of rice bran especially in relation to recently identified antioxidant components. Although the absorption of soya, sesame, palm and other oils by rice hull ash has been studied in the past, no study reported the absorption behavior of rice bran oil and its constituent antioxidant compounds on hull ash, which is silica-rich adsorbent. Hence, the present study was aimed at applying different supercritical conditions with use of RHA adsorption media for combined application of extraction and adsorption processes for rice bran lipids and its important components.

4.2 Materials and Methods

4.2.1 Experimental Procedures

Rice bran obtained from a single variety (Wells) with constant milling conditions was procured after adequate stabilization from Producers Rice Mill (Stuttgart, Arkansas). The rice bran was sieved (14 mesh-1.18 mm) and stored at a temperature of (-16 °C). Agrilectric Power Corporation (Lake Charles, Louisiana) donated industrial rice hull ash with high content of silica (93-97%). The 3-liter pilot scale supercritical fluid extractor used in the current study was

designed and fabricated by Thar Technologies (Pittsburgh, PA). Figures 3.3.1 and 3.3.2 show the picture and the flow diagram of the SFE system, respectively. It was controlled and operated with a personal computer with feedback from pressure, temperature and flow sensors. Combined extraction and adsorption experiments were carried out at different pressures (27.58, 41.37 and 55.16 MPa), temperatures (40 and 60 °C) and flow rates of supercritical carbon dioxide (25, 45 and 65 g/min). Each experiment was conducted in duplicate. Rice bran samples (750 g) were thoroughly mixed with glass beads (3 mm size, 1100 g) before loading bran into the extraction vessel to ensure uniform distribution of the carbon dioxide throughout the vessel and to prevent channeling effects. RHA (200 g) was then placed on top of the bran. Supercritical carbon dioxide at desired temperature, pressure and flow conditions was passed through the extraction vessel and extracts were collected from cyclone collectors at different time intervals (30, 60, 90, 120, 180, 240 min) into pre-weighed sample vials.

The collected extracts were analyzed with normal phase HPLC for concentration of antioxidants. The HPLC system consisted of WatersTM (Milford, Ma) 510 HPLC pump, a 717 plus injector, a 470 scanning fluorescence detector (excitation at 290 nm and emission at 330 nm) and 486 absorbance UV detector (330 nm). A SupelcoislTM (Supelco, Bellefonte, PA) LC-Si, 5µm, 25cm X4.6 mm i.d. column with hexane:ethyl acetate:acetic acid (98.4:0.8:0.8) mobile phase at a flow rate of 1.9 ml/min was used for separation of oryzanol, tocopherols and tocotrienols. The chromatographs from samples were compared with those of standards to calculate concentration of these compounds in the extracted samples. An example of a chromatogram is shown in Figure 3.3.3. To characterize the ash effect, all SFE experiments were repeated without ash. Also, extraction of rice bran lipids with a conventional Soxhlet solvent extraction method was carried out by applying AOAC method (Aa- 4-38) and with petroleum ether as solvent for six hours. The oil samples collected during SFE experiments without ash and

solvent extraction were also analyzed with HPLC. The residual bran and ash at the end of the SFE experiments were then subjected to 6-hour solvent extraction to quantify the residual lipids remaining in bran or adsorbed onto the ash.

4.2.2 Mathematical Modeling

Supercritical extraction of multi-component lipid compounds from the biological materials involving complex and varying vegetative structures is difficult to quantify mathematically. Combining such a process with adsorption phenomena adds to this complexity. Though there are few attempts to mathematically describe lipid extraction from plant materials, none of those involved its combined application with adsorption phenomena.

Different mathematical aspects related to SFE of lipids were described by King and List (1996) that include solubility, phase equilibria and mass transfer, fractionation and modeling. Because of the large number of mathematical variables and complexity of the equations involved in modeling of supercritical extraction of lipids from natural materials, the Goto et al. (1993) model for extraction of essential oil was found applicable to the present study. This model was also applied to fatty acid and carotenoids extraction from microalgae *sprulina maxima* by Canela et al. (2002) and was used in the present study because of the similarity with experimental materials, extraction procedures and the experimental variables. In their application, the mass of extract at the bed out-let was described by the following equation

$$m(t) = \left[\frac{\varepsilon_p}{K} + (1 - \varepsilon_p) \right] \frac{\varepsilon_p}{K} + (1 - \varepsilon_p) X_0 \rho_s Q_{CO_2} A \tau \left\{ \frac{1}{a_1} \left[\exp\left(a_1 \frac{t}{\tau}\right) - 1 \right] + \frac{1}{a_2} \left[1 - \exp\left(a_2 \frac{t}{\tau}\right) \right] \right\} \quad (\text{eq 4.1})$$

Where,

A is a constant defined by the following equation

$$A = \frac{\phi}{\left[\varepsilon_p + (1 - \varepsilon_p) K \right] (a_1 - a_2)} \left(\frac{1 - \varepsilon_1}{\varepsilon_1} \right) \quad (\text{eq 4.2})$$

in which,

$$a_1 = \frac{1}{2}(-b + \sqrt{b^2 - 4c}) \quad (\text{eq 4.3})$$

$$a_2 = \frac{1}{2}(-b - \sqrt{b^2 - 4c}) \quad (\text{eq 4.4})$$

$$b = \frac{\phi}{\varepsilon_p + (1 - \varepsilon_p)K} + \frac{1}{\varepsilon_1} + \frac{\phi(1 - \varepsilon_1)}{\varepsilon_1} \quad (\text{eq 4.5})$$

$$c = \frac{\phi}{[\varepsilon_p + (1 - \varepsilon_p)K]\varepsilon_1} \quad (\text{eq 4.6})$$

$$\text{and } \phi = K_p A_p \tau \quad (\text{eq 4.7})$$

where, ε_1 =interstitial bed porosity

ε_p = particle porosity

K_p = combined mass transfer coefficient

A_p = specific surface area (1/L)

K = particle coefficient of the solvent in the solute

X_0 = initial solute mass ratio in the solid phase

ρ_s = solid true density (M/L³)

Q_{CO_2} = volumetric solvent flow rate (L³/T)

t = extraction time (T)

τ = CO₂ residence time (T)

4.3 Results and Discussions

Extract yield and antioxidant data obtained from the SFE with ash experiment were used to evaluate the effect of the different parameters on the qualitative and quantitative extraction of rice bran lipids with ash. Moreover, similar data obtained from control SFE with bran-only experiments and Soxhlet experiments were used to compare the ash effect on the rice bran oil yield and antioxidants.

4.3.1 Total Oil Yield

Oil yield increased significantly ($P < 0.05$) with an increase in pressure. Figure 4.3.1.1 shows total oil yield at different pressure in case of the ash experiments. At 60 °C and 45 g/min, SFE oil yield increased from 24.2 % (32.5 g) to 91.31 % (122.2 g) of solvent extractable oil when pressure increased from 27.58 MPa (4000 psi) to 55.16 MPa (8000 psi). Oil adsorption on ash was highest (27.05 % of solvent extractable, 36.2 g) at 41.37 MPa whereas residual oil in bran was highest at the lowest pressure (27.58 MPa). This behavior of increased extraction rate with increased pressure was the result of the increase in solvent density with an increase in pressure at constant temperature. Garcia et al. (1996) also reported an increase in extract yield when pressure was increased from 16.5 to 28.0 MPa. Cheung et al. (1998) also reported higher extraction of algal lipids with increase in pressure from 24.1 to 37.9 MPa.

Figure 4.3.1.2 shows the effect of flow rates of carbon dioxide on the extraction and adsorption of oil for ash experiments, where significantly ($p < 0.05$) increased total oil yield occurred with increased flow. As flow increased from 25 to 45 g/min at 55.2 MPa and 40 °C, extract yield also increased from 61.7 % of solvent extractable oil (82.54 g) to 97.2 % (130.11 g). At 41.37 MPa and 40 °C the increase was from 53.1 % to 91.2 % of solvent extractable oil. This indicated that an increase in the convective mass transfer rate has positive impact on oil extraction and that using high flow rate can reduce extraction time and increase the oil yield in case of large systems with recycling of CO₂. Highest adsorption at 55.2 MPa and 40°C was 8.6 % of solvent extractable oil at the lowest flow rate of 25 g/min. As expected, at 55.2 MPa the lowest flow (25 g/min) yielded maximum residual oil in the bran (17.6 % of solvent extractable).

Figure 4.3.1.3 visually indicates increasing trends in total oil extraction yields with increasing temperature. However actual differences in these oil yields due to temperature were not found statistically significant. This indicates that the solvent density, and hence the solvent

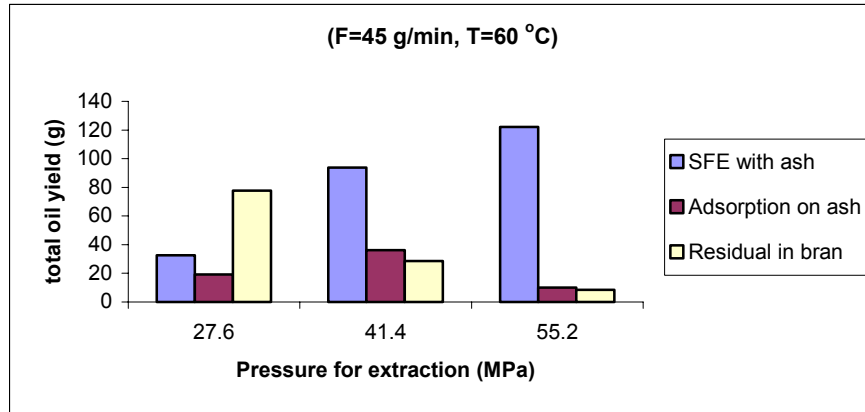

Figure 4.3.1.1 Total oil yield as affected by pressure in SFE with ash experiments

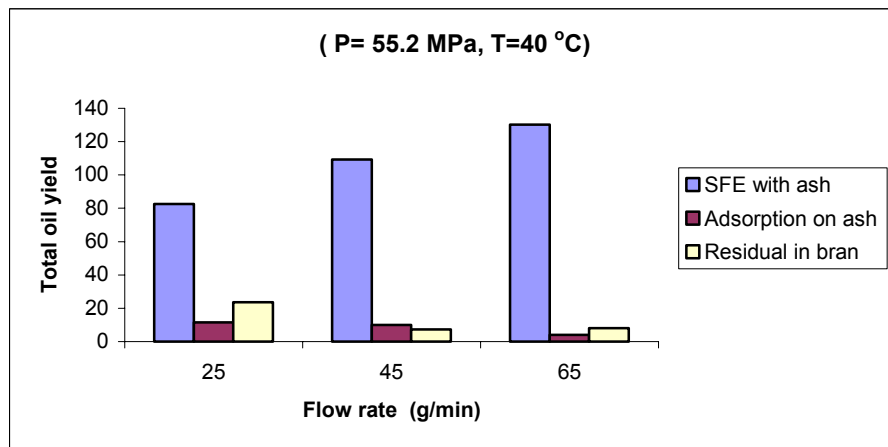

Figure 4.3.1.2 Total oil yield as affected by flow in SFE with ash experiments

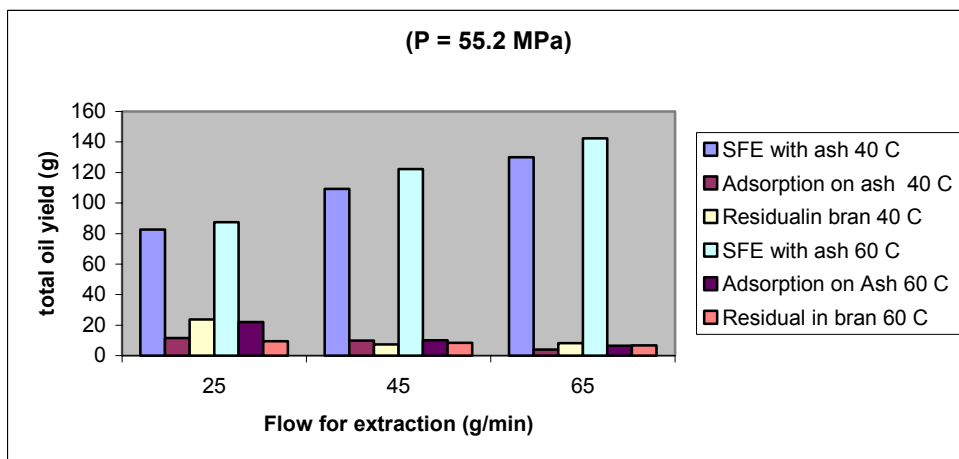

Figure 4.3.1.3 Total oil yield as affected by temperature in SFE with ash

strength did not change drastically with an increase in temperature from 40 to 60°C. Shen et al. (1996) observed higher extract yield at 60°C compared to 40°C in their experiments at 24 MPa, with rice bran where as Garcia et al. (1996) reported lower yield in oil with increased temperature in their experiments at 28 MPa and temperatures of 40-50°C. This indicates that temperature effect on rice bran oil extraction was strongly influenced by other extraction parameters such as pressure, flow rate, system configuration as well as sample sizes. Temperature was also found to have a cross-over effect in solvent density with a rise at constant pressure, which may possibly be explained by retrograde behavior.

4.3.2 Cumulative Extraction and Extraction Rates

4.3.2.1 Effect of Extraction Conditions

Cumulative extract yield and extraction rates were used to describe the extraction process with time. As pressure of supercritical carbon dioxide increased from 27.6 to 55.2 MPa in experiments conducted with ash, cumulative extract yields were significantly ($p < 0.05$) increased with extraction pressures as shown in Figure 4.3.2.1.1 This was mainly because of an increase in density at constant extraction temperature of 60 °C. For example, as shown by Roy et al. (1996) at 40°C density of supercritical carbon dioxide increased from 676.1 to 879.5 kg/m³ when pressure was increased from 10.8 MPa to 24.5 MPa. The maximum yield of 97.2 % of Soxhlet extractable oil was obtained (at 55.2 MPa, 65 g/min, 40°C) where as lowest oil yield of 18.4 % was obtained (at 27.6 MPa, 25 g/min 40°C). Solubility of fats in supercritical carbon dioxide generally increases with an increase in pressure. Turner et al. (2001) indicated that when density of the supercritical fluid is equivalent to density of target analyte, the maximum solubility of analyte may be obtained. Similar increases in yield with increased pressure are reported by Shen et al. (1996) at 17, 24 and 31 Mpa, Garcia et al. (1996) at 10, 16.5 and 28.0 Mpa, and Kim et al. (1999) at 20.68 to 41.37 MPa.

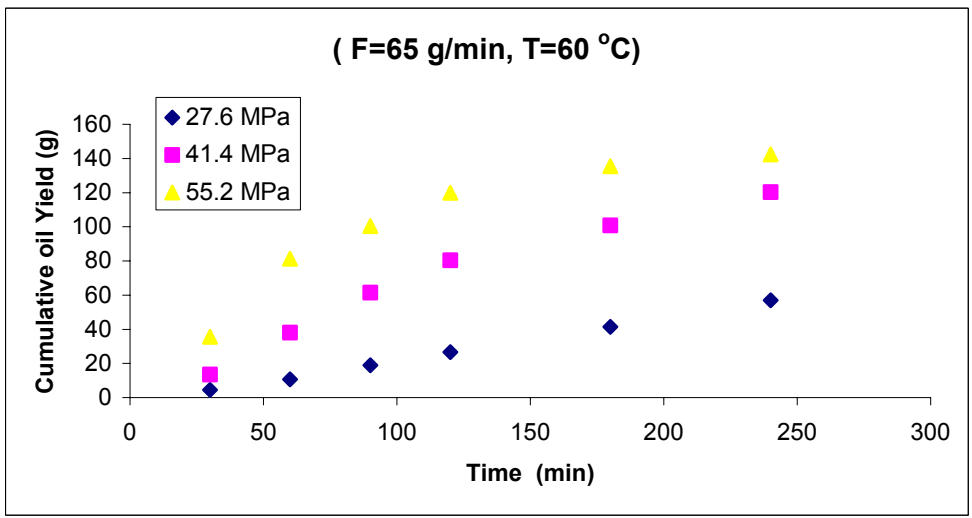
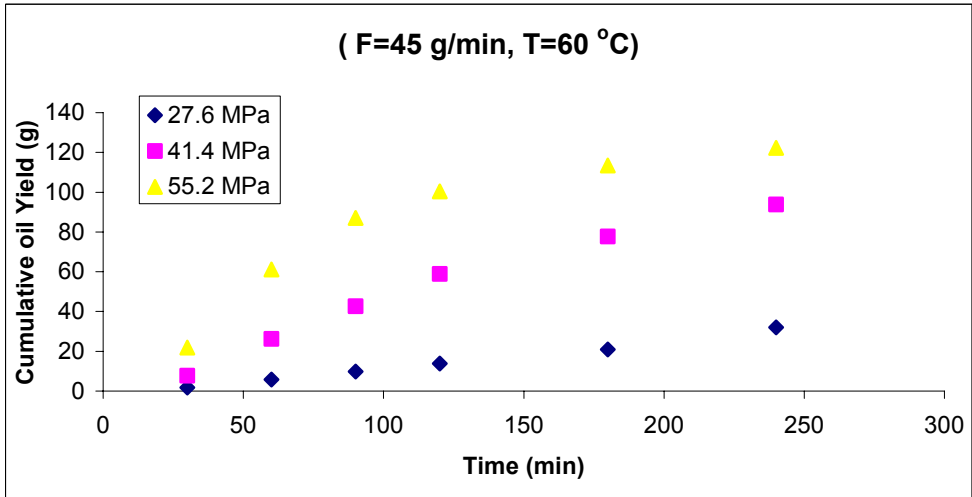
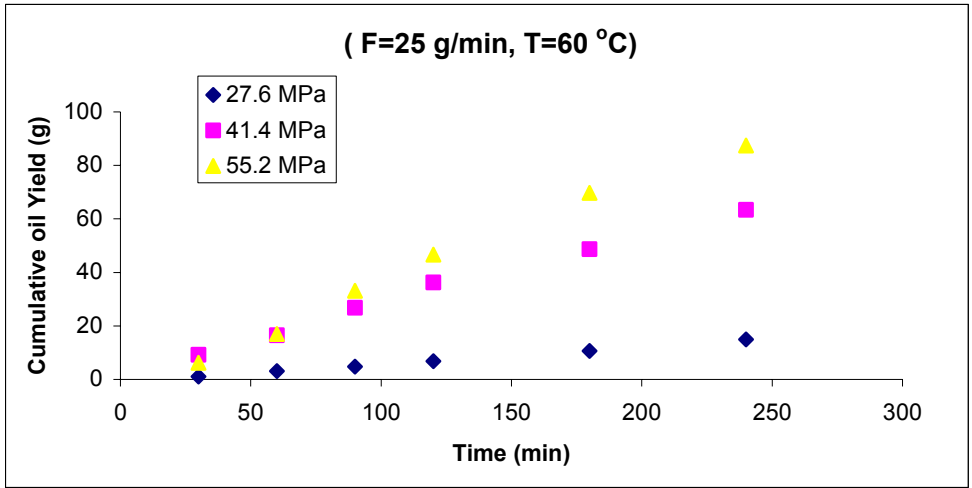

Figure 4.3.2.1.1 Effect of pressure on cumulative oil extraction with ash adsorption

Flow of carbon dioxide also influenced the extraction process significantly ($p > 0.05$) as shown in Figure 4.3.2.1.2. From 750 g of rice bran with a flow rate of 65g/min, oil yield of up to 130.11, 122.12 and 77.41 g were obtained at 55.2, 41.4, and 27.6 MPa whereas 17.01, 63.34, 82.54 g were obtained for the flow rate of 25 g/min. Eggers and Sievers (1989) reported that at constant mass flow rate the extraction curve is linear until being retarded by diffusion within the product thus switching to logarithmic behavior. This may be indicative of the benefit of smaller particle sizes in the extraction process as reported by Reverchon et al. (2000) and Badal (2002). Increases in extract yield with increasing flow rate also indicates that extraction is governed by the solubility of the compound in compressed carbon dioxide.

Temperature effect was not statistically significant ($p > 0.05$) for the extraction experiments with ash in terms of cumulative oil yield. Graphs in Figure 4.3.2.1.3 indicate the temperature effect at different flow rates and pressures. Xu and Godber (2000) observed an increase in adsorption extract yield with increased temperature from 30 to 60°C, but it did not increase further when temperature was raised to 75°C. Garcia et al. (1996) also observed varying temperature effects on extract yields. Turner et al. (2001) reported that when the temperature of a supercritical fluid is increased at constant pressure, the solvent strength is dependent on that respective pressure. At pressures below a cross-over point, increase in temperature decreases solvent density, which reduces extraction efficiency of the analyte. However, above the cross-over point, in spite of a decrease in solvent density, with increasing temperature, extraction nevertheless improves due to a significant increase in vapor pressure of the analyte. Another phenomena, known as retrograde behavior, exists for supercritical fluids that suggests that analyte solubility first increases with temperature at constant pressure due to increased analyte vapor pressure, but with further temperature elevation beyond a certain point where the temperature influence on decreasing solvent density becomes more significant than increasing

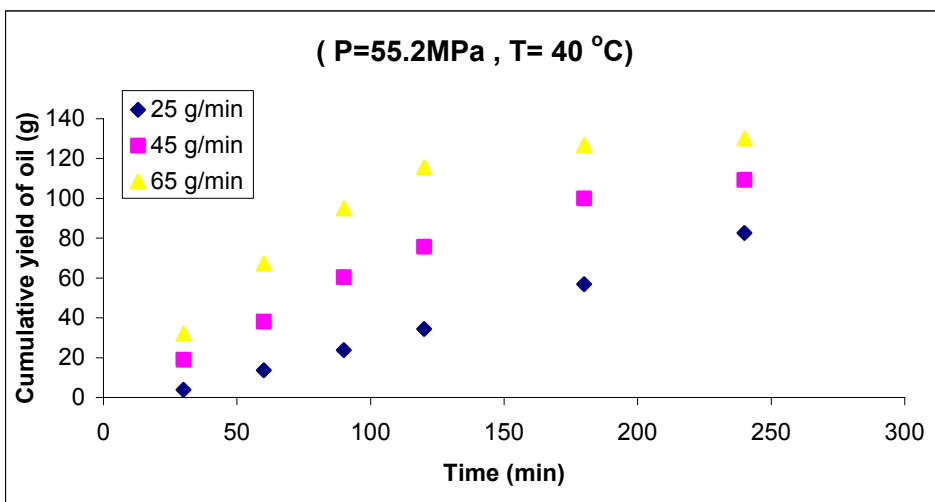
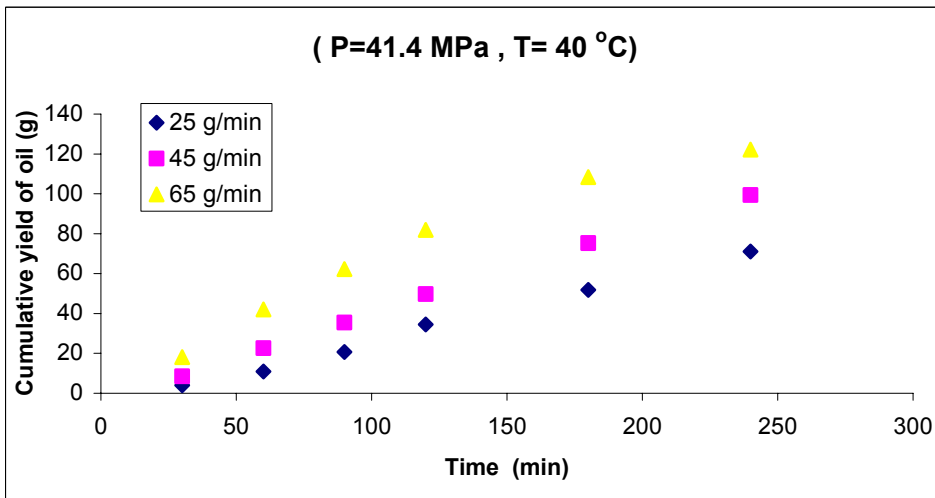
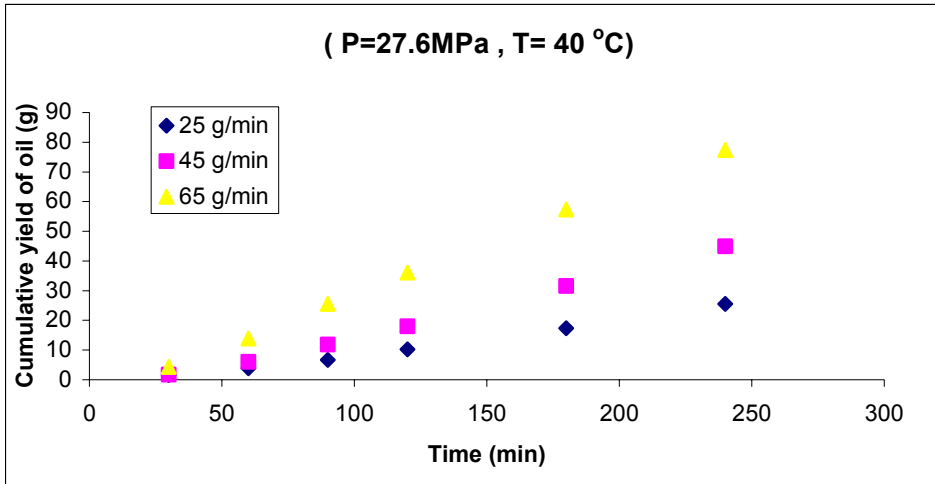

Figure 4.3.2.1.2 Effect of flow on cumulative oil extraction with ash adsorption

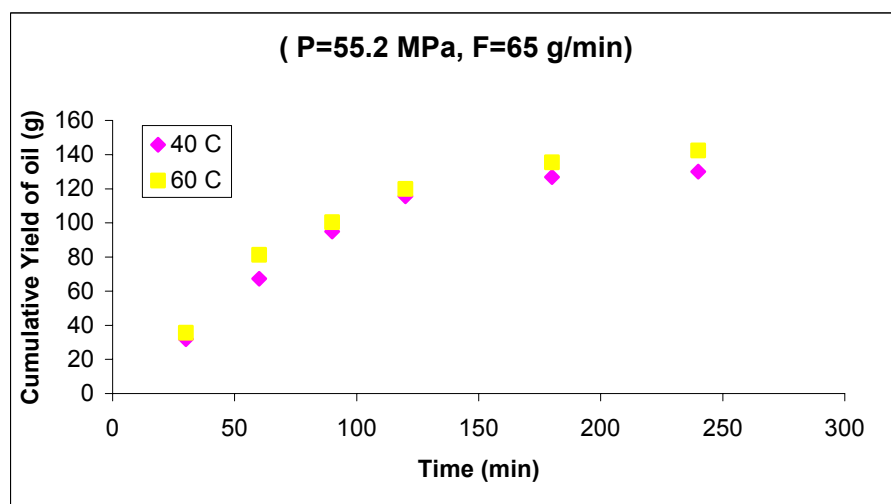
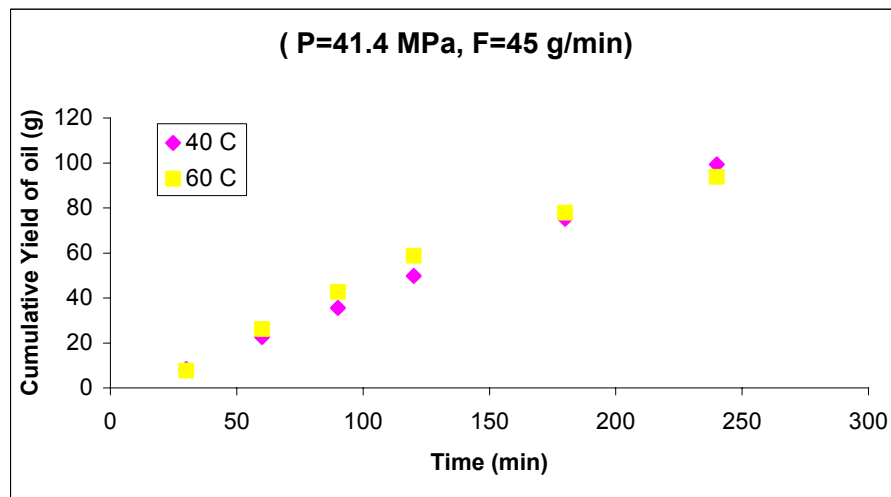
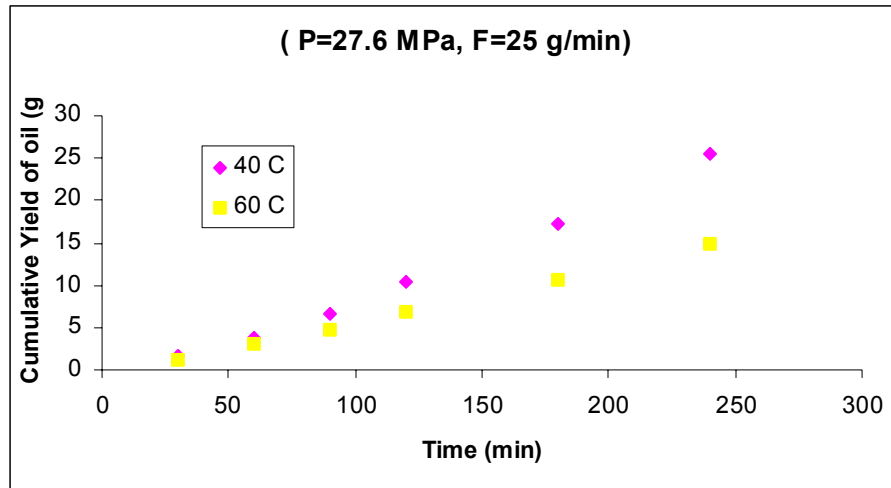

Figure 4.3.2.1.3 Effect of temperature on cumulative oil extraction with ash adsorption

analyte vapor pressure, the solubility of the analyte is then reduced.

4.3.2.2 Mathematical Modeling of Extraction Process

Properties of rice bran and RHA such as surface area, particle size, densities etc. were measured or obtained from the available literature to apply to the present study. Table 3.4.5.1 show property data used in the modeling. Constants such as a_1 , a_2 , b , c and A were calculated with equations 4.2 to 4.7 and resultant values were placed in the mass equation 4.1 to calculate predicated mass of the extract.

Since the results of the extraction behavior for cumulative oil extract yield in combined extraction-adsorption applications in this study did not show any significant variation from experiments without adsorption media present, the SFE extraction model was also applied to this combined extraction-adsorption with the assumption that adsorption behavior for oil was negligible.

Predicted mass of extract using the model was compared with the experimental extraction values by placing approximate values of coefficients in the beginning. The coefficients K and K_p were then varied to obtain the least square difference between the experimental and predicted results. Accordingly, values of K and K_p were optimized within MS EXCEL software to obtain the best fit of the model with experimental values at different experimental conditions of pressure (P), Flow (F) and Temperature (T). Table 4.3.2.2.1 shows the resultant values of partition coefficient K and mass transfer coefficient K_p for the respective experimental conditions. Figure 4.3.2.2.1 shows the comparison between experimental and fitted lines for the different extraction conditions. The Goto model was able to predict the extract yields in combined extraction-adsorption experiments with reasonable accurately for rice bran lipid under the experimental conditions used in the present study.

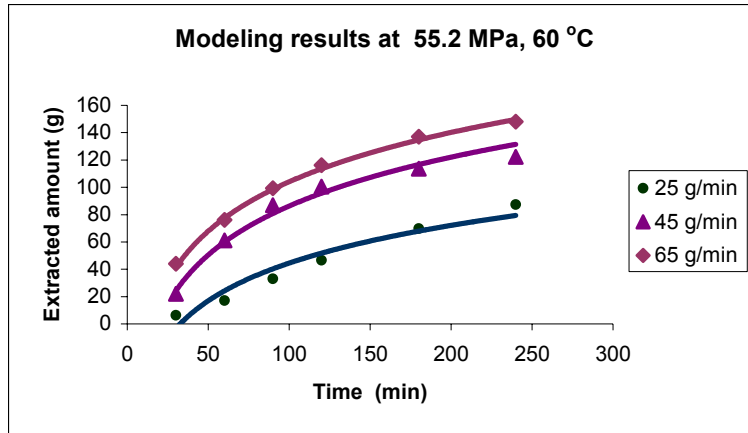

Figure 4.3.2.2.1 Comparing model and experimental values for extraction with ash

Table 4.3.2.1 Modeling results for the co-efficient

Flow g/min	Temp °C	Pressure MPa	K	K _p	r ²	K _p a _p x 100	K X 100
25	40	27.58	0.0329	0.0090	0.95	1.530	3.29
		41.37	0.0230	0.0100	0.97	1.700	2.30
		55.16	0.0210	0.0113	0.98	1.921	2.10
	60	27.58	0.0395	0.0110	0.97	1.870	3.95
		41.37	0.0218	0.0125	0.98	2.125	2.18
		55.16	0.0186	0.0122	0.99	2.074	1.86
45	40	27.58	0.0240	0.0101	0.96	1.717	2.40
		41.37	0.0180	0.0113	0.98	1.921	1.80
		55.16	0.0160	0.0118	0.99	2.006	1.60
	60	27.58	0.0293	0.0127	0.94	2.159	2.93
		41.37	0.0184	0.0136	0.99	2.312	1.84
		55.16	0.0169	0.0121	0.93	2.057	1.69
65	40	27.58	0.0194	0.0100	0.98	1.700	1.94
		41.37	0.0144	0.0100	0.99	1.700	1.44
		55.16	0.0160	0.0120	0.93	2.040	1.60
	60	27.58	0.0224	0.0120	0.96	2.040	2.24
		41.37	0.0160	0.0135	0.99	2.295	1.60
		55.16	0.0136	0.0125	0.98	2.125	1.36

4.3.3 Antioxidants in Rice Bran Oil

Yields of antioxidant components obtained by HPLC were used to characterize the effects of the extraction conditions on antioxidants in SFE with ash experiments. Concentration and yields of the antioxidants increased significantly with an increase in pressure ($p < 0.05$) for the three antioxidants in the SFE with ash experiments. Graphs in Figures 4.3.3.1 represent the pressure effect on concentration of antioxidants. Greater amounts of all antioxidants were extracted at higher pressures most likely due to an increase in solubility of the antioxidant compounds at higher pressure because of increased density and solvent strength of supercritical carbon dioxide. Shen et al. (1996) also reported increased yield of oryzanol when extraction pressure increased from 17 to 24 and 31 MPa at 40 °C.

The effect of flow on antioxidants in rice bran oil was not statistically significant ($p > 0.05$). Graphs in Figure 4.3.3.2 indicate that flow effect on concentration of the antioxidants, which were difficult to characterize from this experimental data. This suggest that though with higher flow the extract yield increased with an increase in convective mass transfer, it did not contribute to an increase in extraction of antioxidant compounds. Statistically, there was no significant difference in extraction of antioxidants due to the temperature ($p > 0.05$), which was similar to temperature effects on yield in these experiments.

Figure 4.3.3.3 shows the temperature effect on antioxidant concentration for SFE with ash experiments. Xu and Godber (2000) found variations in the temperature effect on concentrations of oryzanols from rice bran depending on time of extraction. Shen et al. (1996) found increased α -tocopherol extraction with temperature for extraction of RBO at 24 MPa and 20, 40 and 60 °C, but in the same experiments they obtained lower oryzanol content at higher temperatures. Such variations in temperature effects on antioxidant extraction may be the result

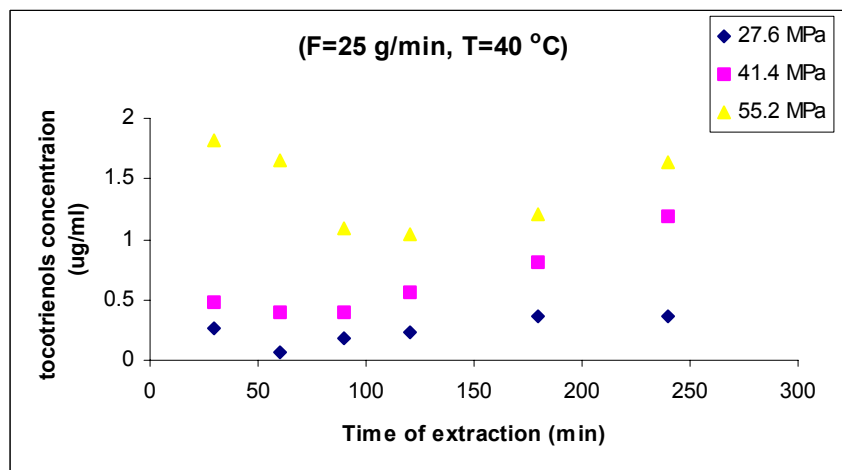
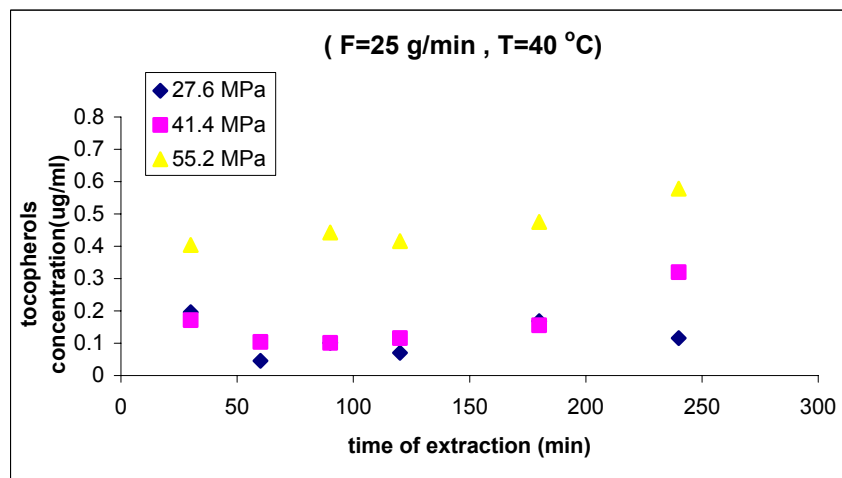
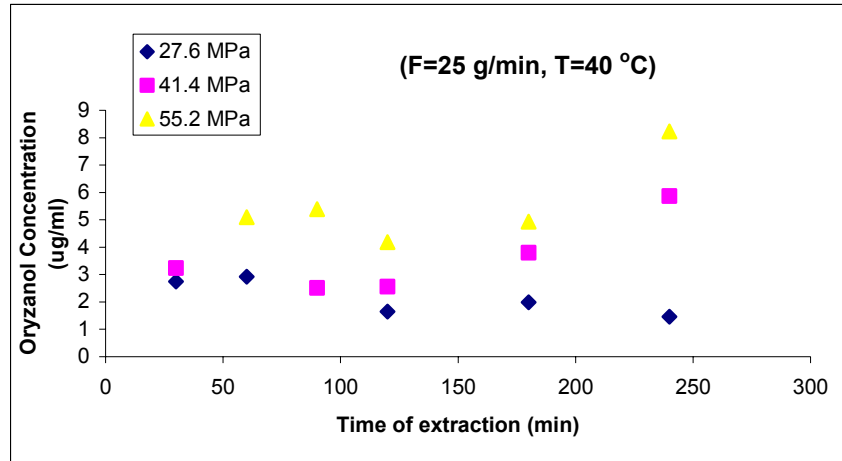

Figure 4.3.3.1 Effect of pressure on concentration of antioxidants in SFE with ash experiments

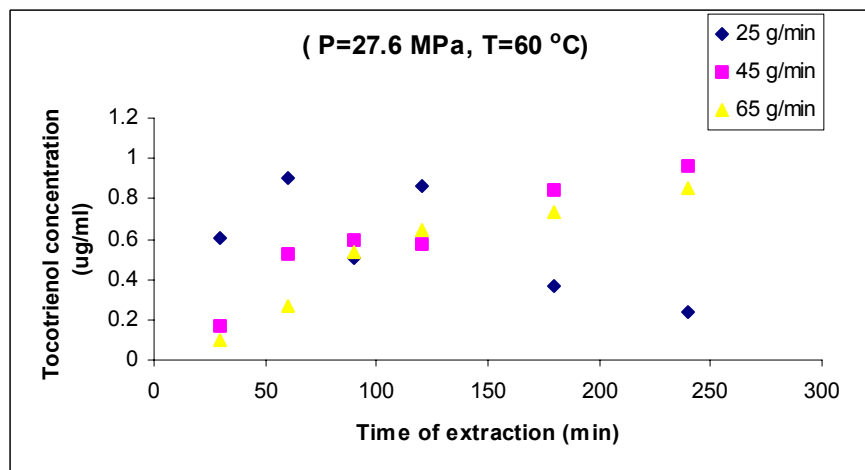
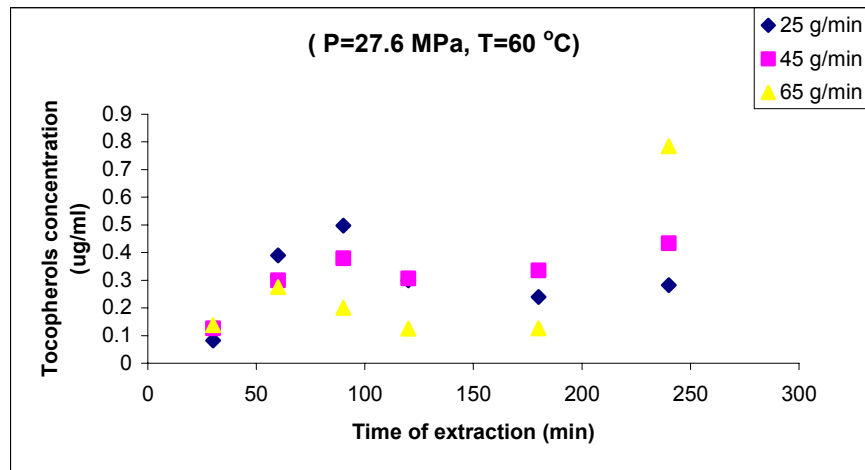
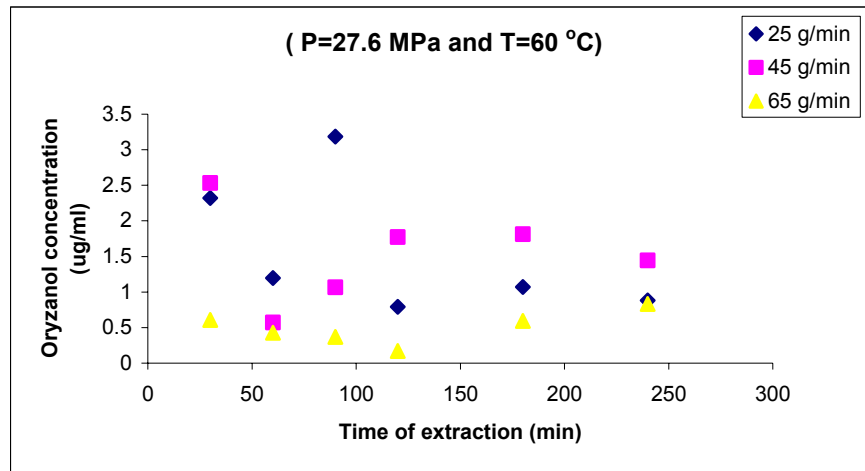

Figure 4.3.3.2 Effect of flow on concentration of antioxidants in SFE with ash experiments

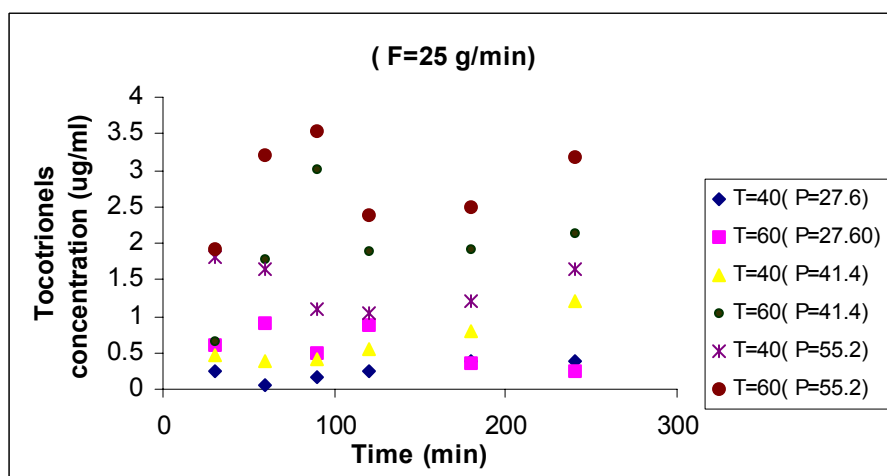
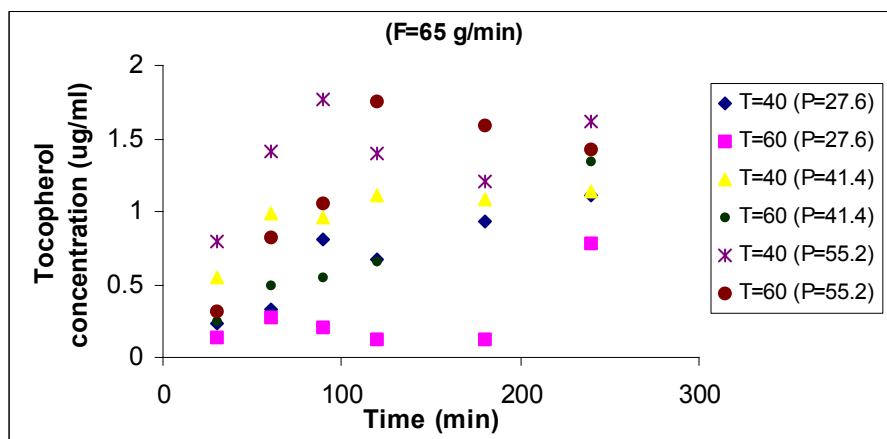
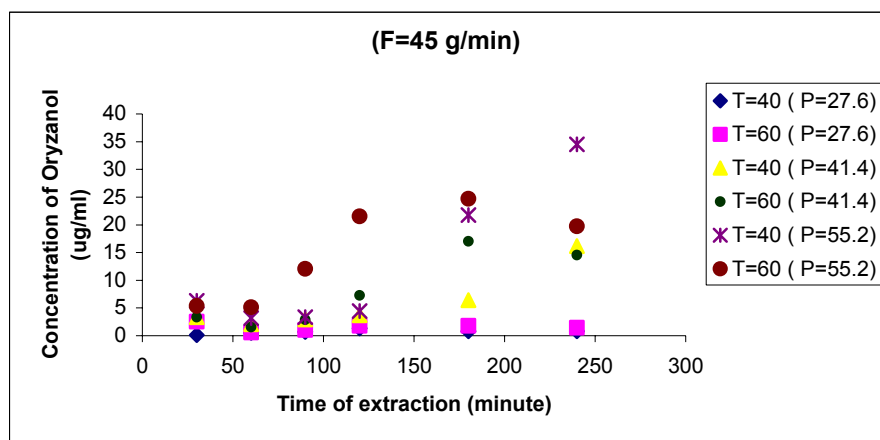

Figure 4.3.3.3 Effect of temperature on concentration of antioxidants in SFE with ash experiments

of the cross-over effect of pressure, at a constant temperature, which was discussed earlier in section 4.3.2.1.

4.3.4 Effect of Ash Adsorption on Rice Bran Oil and Antioxidants

Supercritical extraction with ash was compared with control SF extractions (no ash present). Figure 4.3.4.1 shows the total oil yield in case of different extractions. From the graphs SFE of oil in the presence of ash at higher pressure (55.2 MPa, 65 g/min, and 40 °C) was comparable in terms of total oil yield with SFE of oil from bran without ash and to the Soxhlet solvent using petroleum ether as solvent. This indicates that solvent density of the supercritical fluid at higher pressure and flow rates was strong enough to overcome any ash adsorption effect on the oil yield. The comparable effects observed for petroleum ether in solvent extraction indicated similar solvent strength to SFE. Cumulative yield graphs shown in Figure 4.3.4.2 indicate that SFE extraction with ash showed similar extraction behaviors with time as that of SFE for bran. Though there were minor differences in the oil yields with and without ash, which varied over extraction conditions, these differences were not statistically significant ($p > 0.05$).

Antioxidants in the rice bran oil were significantly ($p < 0.05$) affected by the ash adsorption as expected. Figure 4.3.4.3, 4.3.4.4 and 4.3.4.5 compare SFE with ash extractions to those without ash in relation to antioxidant extraction. Figure 4.3.4.3 indicates that oryzanol concentration was significantly higher in the extract in presence of ash. This behavior was similar to the adsorption with chromatographic phases during HPLC and other techniques in which silica and other adsorbents retain the compounds by adsorption, which is later eluted in high concentration to appear as a distinctive peak with good separation. But the ash effect on the oryzanol concentration was found to be somewhat pronounced compared to that in case of tocopherols and tocotrienols. Ferreira et al. (2002) showed that solubility and composition of oil were affected significantly by the molecular weights of the components using supercritical

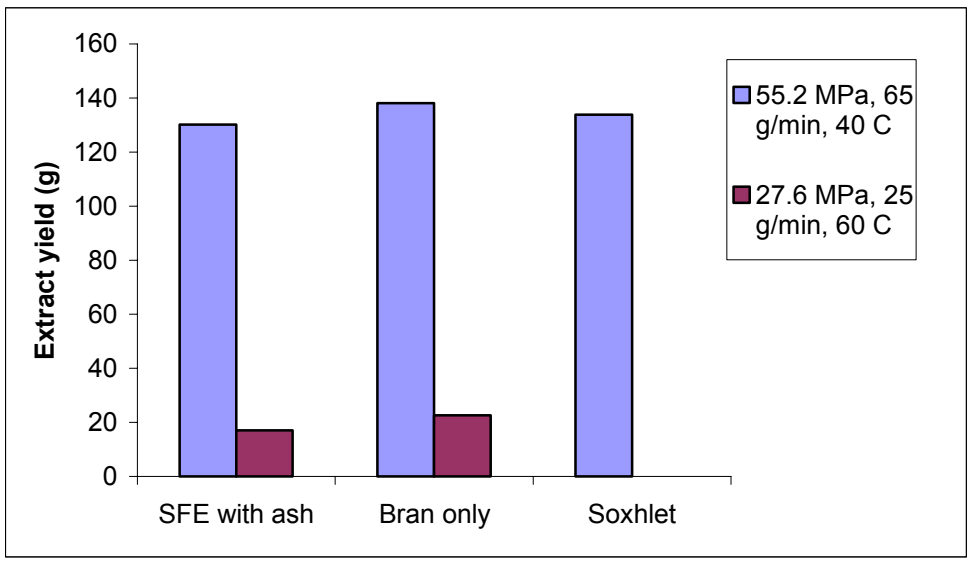

Figure 4.3.4.1 Comparing oil yield in SFE with ash experiments to other extractions

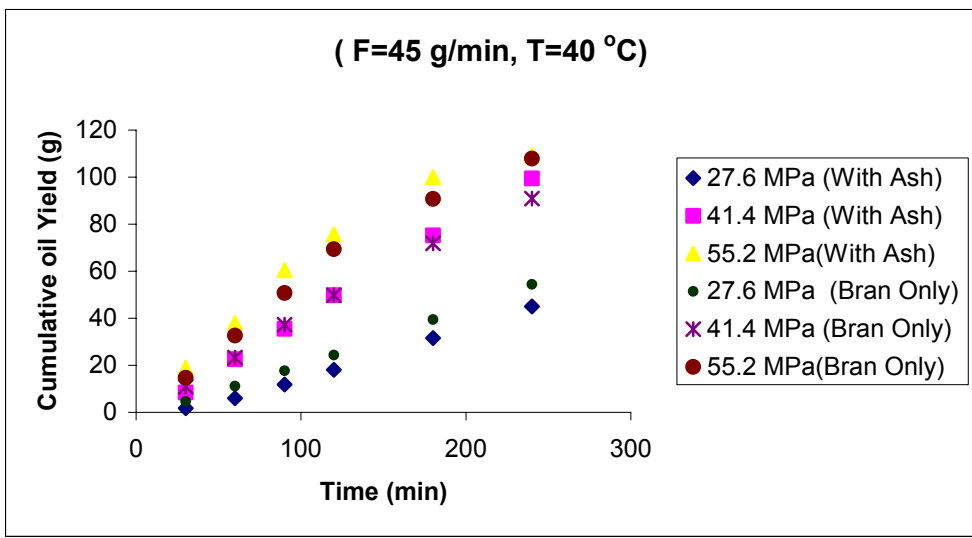

Figure 4.3.4.2 Comparing cumulative oil extraction in SFE experiment with and without ash

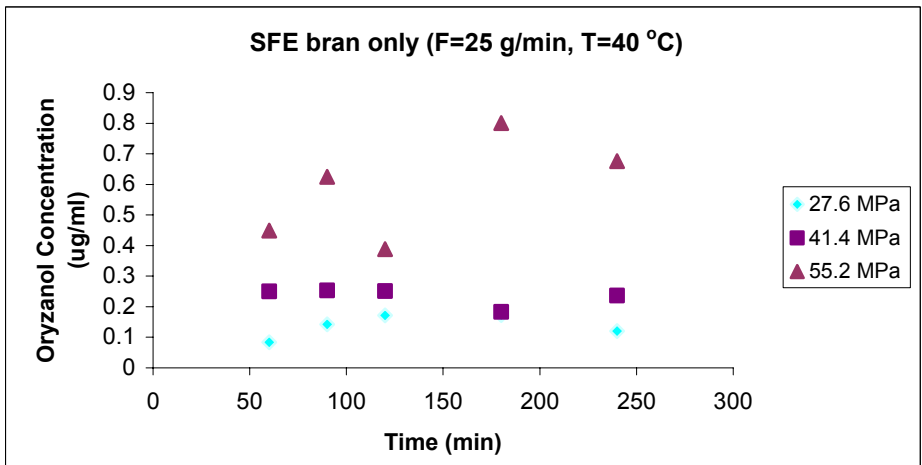
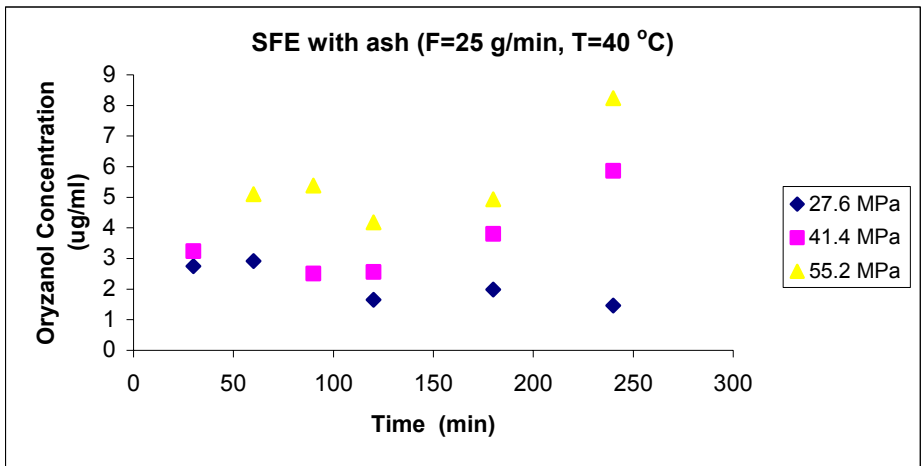

Figure 4.3.4.3 Comparing oryzanol concentrations in SFE experiment with and without ash

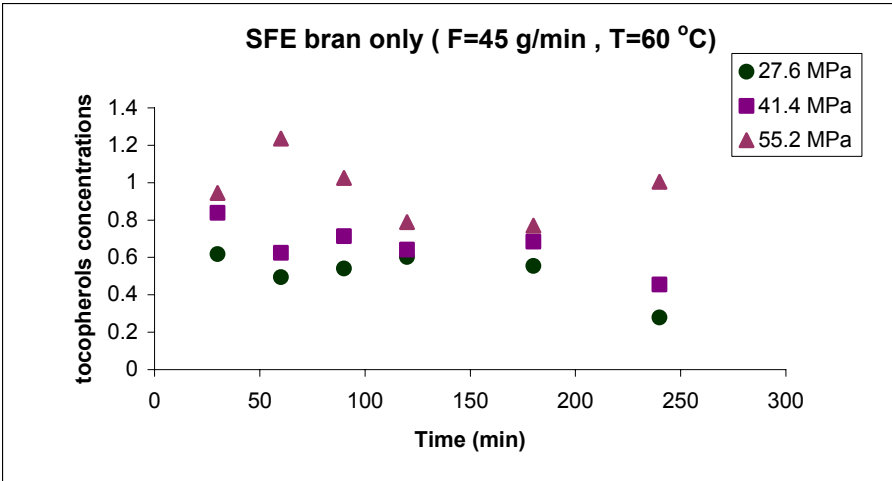
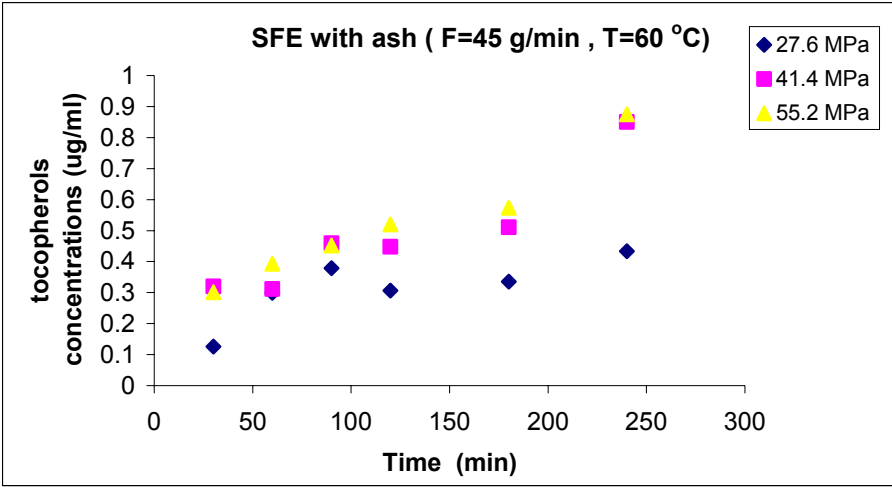

Figure 4.3.4.4 Comparing tocopherol concentrations in SFE experiment with and without ash

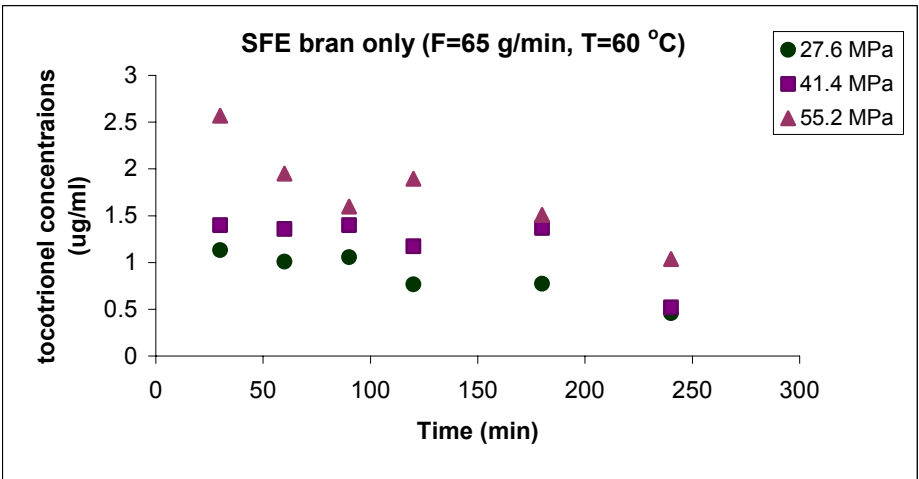
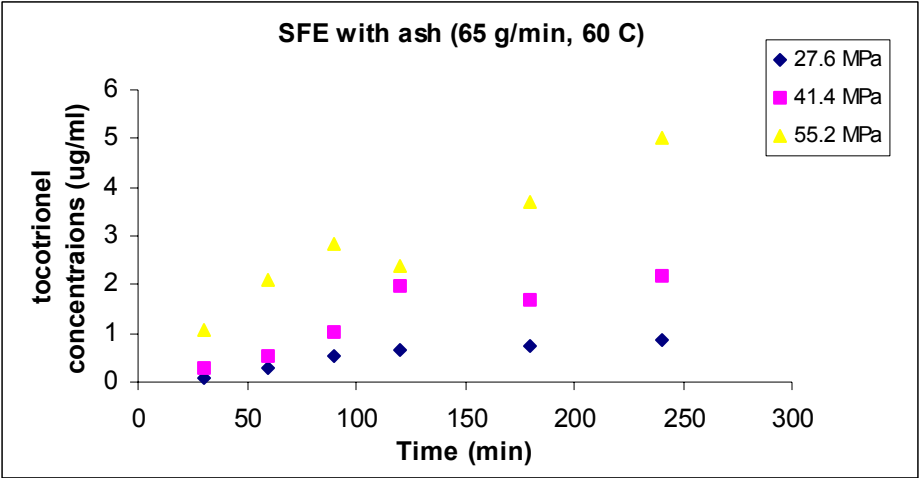

Figure 4.3.4.5 Comparing tocotrienols concentration in SFE experiment with and without ash

extraction of black pepper essential oils. Hu (195) reported differences in physical properties of the rice bran oil components describing Vitamin E (tocopherols and tocotrienols) as viscous oil components with boiling point of 200-220 °C, whereas oryzanol was a powder with a melting point range of 137.5 to 138.5 °C. Shen et al. (1996) reported that, in comparison to the tocopherols, free fatty acids, triglycerides, and oryzanols were more difficult to extract. Though oryzanols are lower (~270 Da) than triolein in molecular weight, they have more rigid and voluminous polycyclic structure and linkages with other components of the bran. These studies indicate that oryzanols are more difficult to extract compared to other compounds of rice bran lipids. Also as shown in HPLC chromatogram shown in Figure 3.3.3, oryzanol components are eluted at much later time of approximately 25 minutes compared to vitamin-E components of tocopherols and tocotrienols. This shows that oryzanol is adsorbed more strongly on the ash. Tocopherol extraction was also significantly affected by ash ($p < 0.05$) as can be seen in Figure 4.3.4.4. With SFE of bran only experiments, tocopherols concentrations declined with time as extraction progressed. With ash adsorption, the extraction resulted in lower tocopherol concentration in the extract initially then increased as extraction progressed. Ambrogi et al. (2003), who studied a combined extraction-adsorption process for separation of carotene, also found that composition of carotenoids was significantly affected by the presence of silica adsorbent after the extraction process. Here, also, a significant delay was observed due to adsorption phenomena. They observed variation in concentration depending on type of adsorbent, due to variation in surface and ionic characteristics. This indicates that structural differences in the tocopherols and oryzanol might be responsible for different adsorption behavior of these compounds with constant surface and ionic characteristics of RHA silica surface. Figure 4.3.4.5 shows extraction behavior of tocotrienols with ash compared to bran only experiments. The ash effect on the tocotrienols was similar to that of tocopherols, i.e. higher

initial extraction with bran only experiments whereas lower initial extraction occurred in experiments with ash due to the adsorption. Since, tocopherols and tocotrienols are structurally similar compounds, there similar adsorption behavior with rice hull ash shows the agreement with the earlier discussion of the adsorption dependence on structural characteristics.

Chapter 5

Adsorption of Antioxidant Compounds on Rice Hull Ash from Rice Bran Oil

5.1 Introduction

Rice bran is nutritionally rich with 16–22% lipid, 12–16 % protein, 8-12 % crude fiber and high levels of other vitamins and minerals (Saunders, 1990). The high content of lipids make bran a commercially viable feedstock for oil extraction. Rice bran oil (RBO) has oleic acid (38.4 %), linoleic acid (34.4%) and linolenic acid (2.2%) as unsaturated fatty acids, and palmitic (21.5%) and stearic acid (2.9%) as saturated fatty acids (Rukmani and Raghuram, 1991; Xu, 1998). Three major fatty acids include palmitic, oleic and linoleic, which make up 90 % of the total fatty acids of the RBO. Rice bran is a good source of linoleic acid that is essential to human health (Ramezanzadeh et al., 2000). The fatty acid composition of RBO is similar to peanut oil although the level of unsaponifiable lipid is higher.

RBO also contains nutritionally important antioxidant compounds that include oryzanols, tocopherols and tocotrienols (Godber et. al., 1994). These antioxidant compounds are beneficial in lowering cholesterol as well as preventing cardiovascular diseases (Lloyd et al., 2000). Tocopherols are also believed to have anticancer effects (Tarber and Packer, 1995; Dunford, 2001). Oryzanols lower harmful cholesterol (LDL) without reducing good cholesterol (HDL) (Nicolosi et al., 1992; Dunford, 2000). Oryzanols, tocopherols and tocotrienols, as antioxidants, give improved stability to the rice bran lipids and also improve the frying quality of RBO (Llyods et. al. 2000, Yuki and Ishikawa, 1976, Duve and White, 1991; Sonntag, 1997; Xu, 1998).

The rice hull (husk) also constitutes an important by-product of the rice milling industry

accounting for approximately 20% of the paddy's weight. Rice husks are rich in cellulose(28-36 %), crude fiber (34.5-45.9 %) and ash (13.2 –21.0 %) (Juliano, 1985). The environmentally-sound disposal and use of large quantities of hull is a challenging issue for rice processors around the world. In countries like the USA where the rice milling industry is well organized and mills are large, rice hulls are burnt to generate thermal power for drying and other mill operations. Rice hull energy content ranges between 13.8 –15 MJ /kg (Juliano, 1985). Rice husk ash (RHA) is an end product of the combustion of rice husk. The chemical composition of ash varies according to the conditions in the gasifier used for burning the husk. RHA contains a very high content of silica that has very good absorbent properties. RHA has the potential to replace other conventional sorbent materials such as bleaching earth, clay, activated carbon, silicate, etc. in various industries. In the past decade, just a few studies have been reported that are related to the use of RHA as an adsorbent. These studies mainly dealt with the adsorption of components from oils and wastewater.

Adsorption studies for oil components with RHA include fatty acids, lutein, phospholipids, etc. from soya, palm, sesame and other oils. When compared with that of commercial bleaching clay and silica hydrogel, RHA adsorbed more xanthophylls, lutein, phospholipids, free fatty acids and peroxides per unit surface area from soy oil. However, RHA was not as effective as silica hydrogel on the basis of weight of adsorbent used (Proctor et al., 1995). Soy oil phospholipid adsorption on acid activated RHA was found higher for smaller doses of adsorbents (Proctor et al., 1992). Lutien adsorption from soy oil on RHA increased with 5 % acid activation (sulfuric acid), but free fatty acid adsorption from soy oil was found to decrease (Proctor and Pallanippan, 1989&1990). Soya oil adsorption studies for phospholipids, using silica (Brown and Snyder, 1985& 1989), and for lutein, using silicic acid (Proctor and Snyder, 1987) have also been reported.

Studies of adsorption of carotene from palm oil by rice hull ash (treated with 20 % sulfuric acid, followed by washing with de-ionized water) indicated that unwashed acid activated ash was more effective. Relative adsorptive activities of acid-treated RHA were higher than carbon and silica, but lower compared with bleaching clay (Liew et al., 1993). The adsorption of monoglycerides of palmitic and oleic acids was achieved from palm oil on RHA and yielded 15.8 mg of adsorption per gram of ash in the case of monopalmitin (Ooi and Leong, 1991). When adsorption efficiency of RHA for free fatty acids and carotenoids from sesame oil was compared with two commercial adsorbents, synthetic silica and wood carbon (vegetable carbon), RHA retained most of the oil, while silica had lower retention compared with wood carbon (Jorge et al., 2000). Decolorization studies on rubber and melon seed oil using fuller's earth, activated charcoal and their mixture (1:1) at three different temperatures, produced Freundlich and Langmuir isotherms, which indicated the formation of a monolayer on the adsorbent. Also, an increase in adsorption with increased temperature due to an increase in active sites (Achife and Ibemesi, 1989) was observed. Other studies involving RHA as an adsorbent for oil components include adsorption of saturated fatty acids (Farook and Ravendran, 2000), lauric, myristic and stearic acids (Idris and Farook, 1994), myristic, palmitic and stearic acids (Huseyin and Yuksel, 1999).

Rice hull ash is also suited for the adsorption from other mediums apart from oil, such as organic waste water substances from cargo red and vacuum pump oil in a packed bed (Chou et al., 2001), decolorization of raw sugar solutions (Ahmedna et al., 1997), protein adsorption (Jeyashoke et al., 1996), purification of bacteriocins from freeze dried culture supernatants (Janes et al., 1998), Hg (II) adsorption from aqueous solutions (Tiwari et al., 1995), basic blue dye adsorption from textile effluent (Ahmed and Ram, 1992) and adsorption treatment of textile dyes (Sumanjit , 2001).

An adsorption isotherm represents the equilibrium relationship between the concentration in the fluid phase and the concentration in the adsorbate particles at a given temperature and pressure. These isotherms are useful for indicating the affinity of an adsorbate for a particular adsorbent. Langmuir and Freundlich isotherms have been widely used to describe adsorption behaviors. Langmuir (1916) derived a relationship for q (weight of component adsorbed for unit weight of adsorbent) and C (concentration of a component in a fluid) based on several assumptions, such as a uniform surface, a single (mono) layer of adsorbed material and constant temperature.

$$\frac{1}{q} = \frac{1}{q_m} + \frac{1}{q_m K_a C}$$

where q_m = amount of adsorbate adsorbed to form monolayer coverage on adsorbent and

K_a = Langmuir adsorption equilibrium constant.

The above equation describes the Langmuir isotherm in its linear form. Farook and Ravendran (2000) used the Langmuir isotherm to describe saturated fatty acid adsorption by acidified RHA from palm oil. All fatty acid adsorption showed the linear form of the Langmuir isotherm. Idiris and Adam (1994) also found that adsorption of FFA, such as lauric, myristic and stearic acids, on RHA may be described with Langmuir isotherms.

Freundlich proposed an empirical relation for the amount adsorbed per unit weight of adsorbent versus the concentration in the fluid at the equilibrium given as

$$q = K_f C^n$$

where K_f and n are coefficients

q = weight adsorbed per unit wt of adsorbent

C = concentration in the fluid

Taking logs and rearranging

$$\log q = \log K_f + n \log C$$

Free fatty acid adsorption from soy oil by rice hull ash followed a Freundlich type isotherm. (Proctor and Palaniappan, 1990). Adsorption efficiency of pine wood carbon, commercial silica and RHA for the adsorption of FFA and carotenoids were compared with use of the Freundlich isotherm (Vazquez et al., 2000). Langmuir and Freundlich adsorption isotherms were also applied to bleaching of rubber and melon seed oil, which confirmed adsorption of the coloring compounds of oil followed monolayer adsorption and indicated an increase in active sites with a rise in temperature (Achife and Ibemesi, 1989).

Antioxidant compounds of the RBO have gained increased importance due to their nutritional and health benefits. RHA adsorbents have successfully adsorbed other important lipid components such as fatty acids, phospholipids, lutein, carotene etc. Though several studies regarding adsorption of lipid components using RHA have been reported in recent literature, adsorption of the important antioxidant compounds reported in this chapter using rice hull ash adsorption medium has yet to be studied. Hence, in present study, RHA adsorbent was used to adsorb antioxidant compounds of oryzanol, tocopherols and tocotrienols from the rice bran oil hexane miscella at varying conditions and the resulting adsorption isotherms were used to characterize adsorption behavior.

5.2 Materials and Methods

Agrilectric Power, Lake Charles, Louisiana, donated industrial RHA for experimental use. The Agrilectric Corporation has built a 13 MW electricity plant that generates electricity from rice hulls. The rice hull ash used in this experiment was a by-product from this plant. The detailed composition of rice hull ash as per the manufacturer's analysis is given in Table-5.2.1

Table 5.2.1 Quantitative analysis of rice hull ash used in experiments

Major Constituents	Concentration (%)
Silica (Amorphous)	93-97
Caron	3-7
Trace Constituents	Concentration (ppm)
Arsenic	1.91
Barium	42.25
Cadmium	0.13
Chromium	0.33
Lead	< 0.14
Mercury	< 0.03
Selenium	0.181
Silver	< 0.1
Zinc	67.9
Aluminum	59.85
Antimony	< 0.27
Calcium	3240
Copper	8.155
Iron	216
Magnesium	1220
Manganese	531.5
Nickel	< 2.01
Potassium	0.87
Sodium	244.5

Source: Agrisilicas LLC by Agrilectric Co.
Lake Charles, LA

The properties of rice hull ash, such as particle size and surface area were measured at CAMD lab of LSU, Baton Rouge, LA.

An adsorption study was conducted using commercial rice bran oil and industrial RHA. Three different weights of ash (5, 10, 20 g) were mixed with 100 ml of rice bran: hexane miscella (20:80 v/v) and was agitated using stirrer at 200 rpm. The oil samples were kept in the agitator for different durations (30, 60, 90, 120 and 180 min) and the agitator inside environment was kept at different temperatures (20, 30 and 40°C). After agitation, the mixture in the flask was filtered using Whatman filter paper, and residual quantity of unadsorbed oil was measured using a graduated cylinder. Oil adsorbed on the hull ash for each sample was calculated from the difference in initial and final volumes of the miscella in the flask. The sample of unadsorbed oil was collected and analyzed using HPLC to determine the adsorption of the important components of the bran oil.

The sample collected after adsorption (1 ml) was analyzed with normal-phase HPLC to determine antioxidant concentrations. The HPLC system consisted of WatersTM (Milford, Ma) 510 HPLC pumps, a 717plus WatersTM injector, a 470 scanning fluorescence detector (for tocopherols and tocotrienols) with excitation at 290 nm and emission at 330 nm. A SupelcosilTM (Supelco, Bellefonte, PA) LC-Si, 5 μ m, 25cm X4.6 mm i.d. column was used. The mobile phase consisted of hexane:ethyl acetate:acetic acid (98.4:0.8:0.8) with a flow rate of 1.9 ml/min. For analysis of oryzanol, the same system and sample was used, but the detector was UV at the 330 nm using a WatersTM 486 UV absorbance detector. The chromatograms (Figure 3.3.3) obtained with the above system for a given refined rice bran oil sample were compared with those of standards to obtain the concentration.

5.3 Results and Discussions

Adsorption and HPLC data obtained from the batch study for adsorption of antioxidant compounds from rice bran oil at different temperatures and initial amounts of RHA were used to calculate adsorbed concentration and mass of antioxidant compounds as well as equilibrium concentration of the components in the miscella. Figure 5.3.1 shows adsorbed amount of the antioxidant compounds at different times. As can be seen from the graphs, adsorbed amount increased for first 30 minutes and then remained fairly constant for all three antioxidant compounds. Similar results were obtained by Kao et al. (2000) for chlorophenols adsorption with fly ash, in which equilibrium was achieved in 1 h. When different antioxidants were compared, adsorption behavior of oryzanol was different from tocopherols and tocotrienols. Hu (1995) reported differences in physical properties of the rice bran oil components describing Vitamin E (tocopherols and tocotrienols) as viscous oils with boiling point of 200-220°C, whereas oryzanol was a powder with a melting point range of 137.5 to 138.5 °C. Because oryzanols have more rigid and voluminous polycyclic structure and linkages with other components of the bran, this structural differences could have played a major role in the differences in their adsorption behavior on the RHA.

Similar differences in adsorption on rice hull ash in a supercritical phase were also observed in a separate set of experiments (Section 4.4, page 114). These results of differences in adsorption behavior of vitamin E and oryzanol components, if correlated with Figures 3.3.3, it seems that oryzanol was retained for longer time on the silica column in HPLC analysis also. So this behavior might be responsible for significantly higher oryzanol concentration obtained with ash compared to SFE without ash experiments. Figures 5.3.2, 5.3.3 and 5.3.4 show the adsorption of oryzanols, tocopherols and tocotrienols at different temperatures, respectively. The

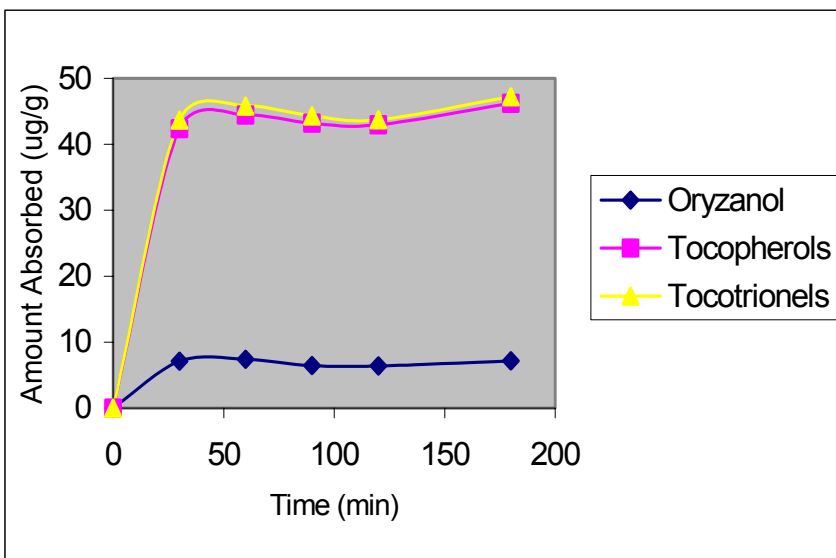

Figure 5.3.1 Effect of time on adsorption of antioxidants

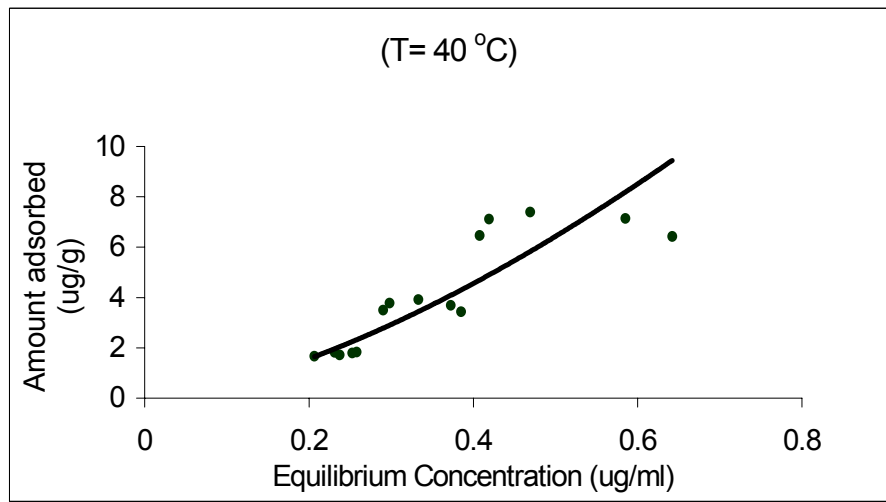
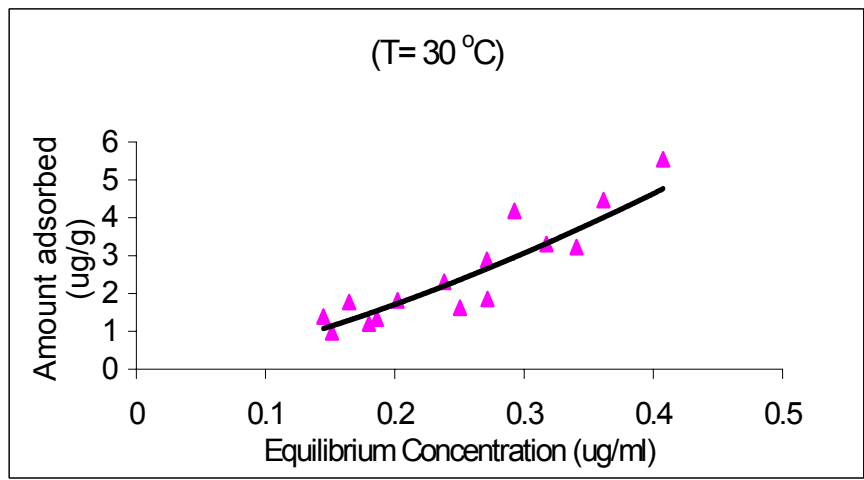
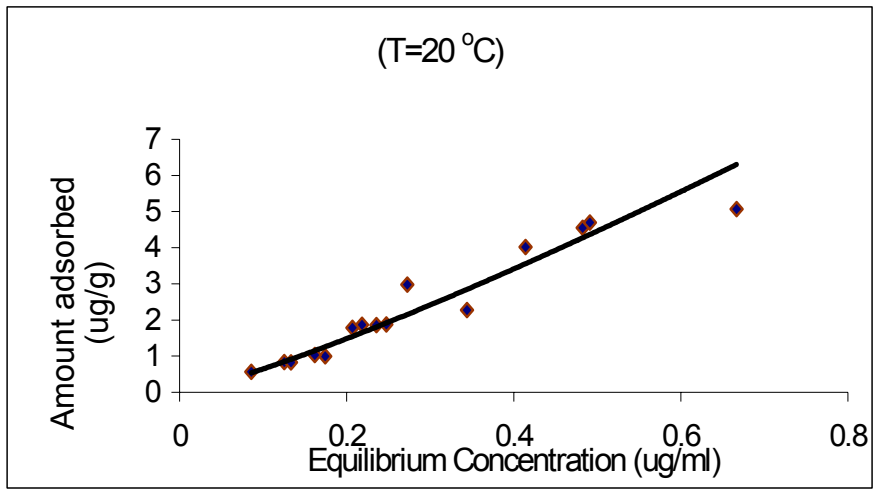

Figure 5.3.2 Adsorption of oryzanol at different temperatures

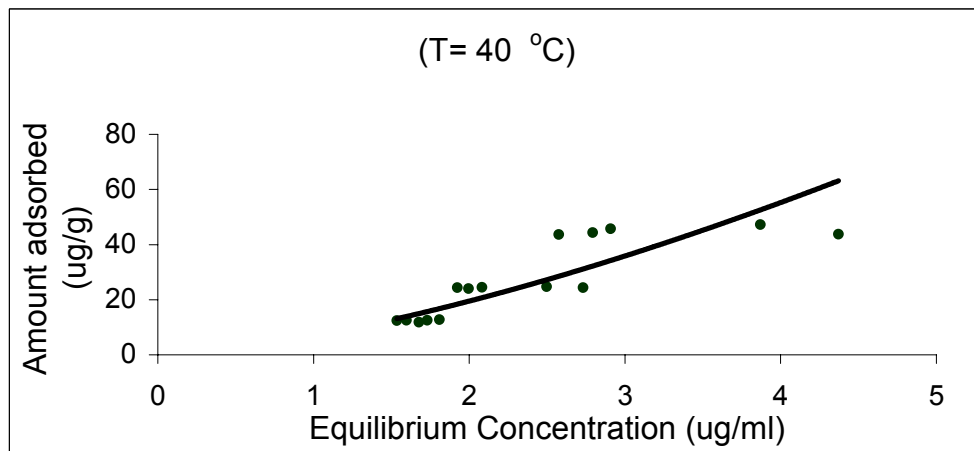
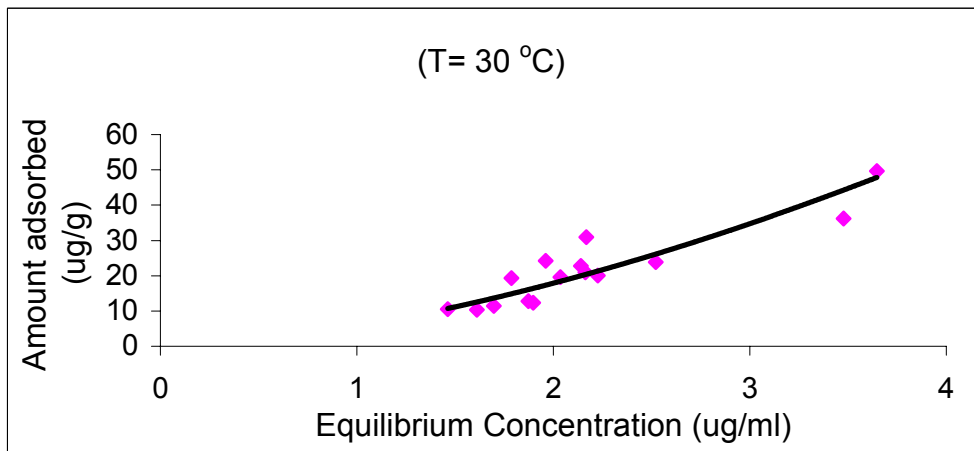
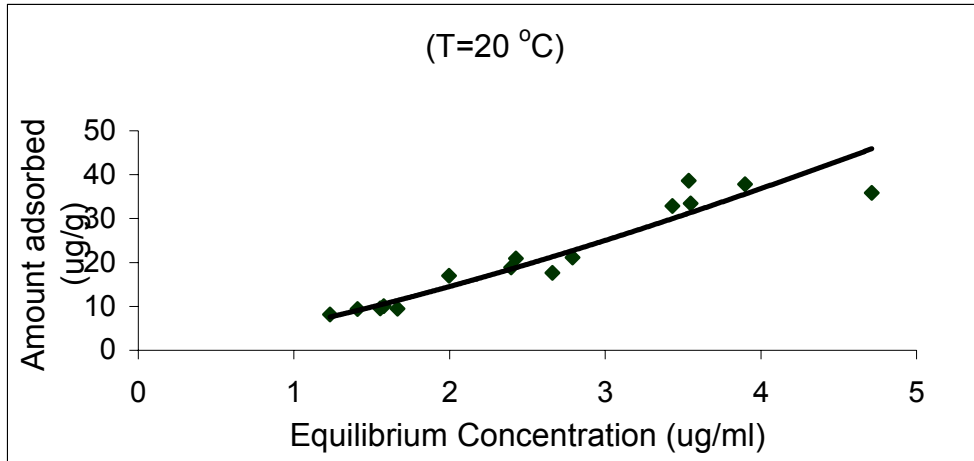

Figure 5.3.4 Adsorption of tocotrienols at different temperatures

adsorption data were also used to fit the Freundlich adsorption isotherm in the form of the following equation.

$$\frac{x}{m} = kC_{eq}^{1/n}$$

where, x = amount of adsorbate adsorbed (ug)

m= amount of adsorbent (g)

C_{eq} = Concentration of residual amount of adsorbate at equilibrium (ug/ml)

k and n = Freundlich fitting parameters

Experimental data were fitted to the above Freundlich equation and fitting parameters (k and 1/n) were determined. Resultant values of fitting parameters for the adsorption of oryzanol, tocopherols and tocotrienols are shown in Table 5.3.1. It can be seen that, *k* increases with temperature in the case of oryzanol whereas with of tocopherols and tocotrienols *k* values decrease with increased temperature. This indicates that adsorption of oryzanol was favorable at higher temperature whereas adsorption of tocopherols and tocotrienols was favorable at lower temperatures. Oryzanol is a mixture of ferulic acid esters of sterols and triterpene alcohols. Tocopherols and tocotrienols are similar compounds with difference in the number and position of methyl groups on the fused chromanol ring and the absence or presence of three double bonds in the isoprenoid side chain. Hence, these structural differences between oryzanol compared with tocotrienols and the similarity between tocopherols and tocotrienols could be the reason for above adsorption behavior in relation to Freundlich fitting parameters.

Van't Hoff-Arrhenius equation is given as

$$\ln k = -\frac{\Delta H}{RT} + C \quad \text{Where, } \Delta H = \text{the enthalpy change in reaction (kcal/mol)}$$

R= ideal gas constant (1.987 cal/mol) and C = Arrhenius constant.

The k values given in Table 5.3.1, along with absolute temperature values for the

Table 5.3.1 Freundlich parameters and enthalpy change

Antioxidant	Temperature (°C)	Freundlich adsorption Parameters		ΔH (kcal/mol)
		k	1/n	
Oryzanol	20	10.263	1.2015	5.501
	30	17.347	1.4399	
	40	18.682	1.5392	
Tocopherols	20	5.6663	1.3382	-2.299
	30	4.4197	1.9032	
	40	4.414	2.2020	
Tocotrionels	20	5.7293	1.3424	-1.652
	30	5.1728	1.7647	
	40	4.7798	2.0463	

experiment (293, 303 and 313°K), were used to plot the Arrhenius equation as shown in Figure 5.3.5. From this plot, the enthalpy values (ΔH) were obtained and are given in the Table 5.3.1. The positive value of the enthalpy change for oryzanol indicate the adsorption process was endothermic, whereas negative values of ΔH in the case of tocopherols and tocotrienols indicates the process was exothermic. The HPLC chromatogram given in Figure 3.3.3 also indicates that oryzanol is retained for more time on the silica of the column compared to the tocopherol and tocotrienols. So this behavior also confirms the differences in adsorption characteristics of these components. An attempt to fit the Langmuir equation to the experimental data, gave poor results. Based on this study adsorption behavior of the oryzanol was different compared with that of the tocopherols and tocotrienols.

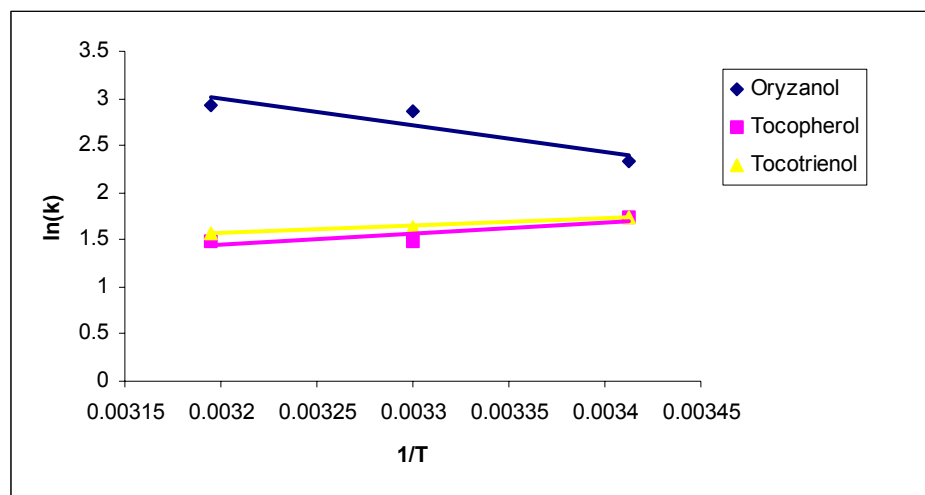

Figure 5.3.5 Arrhenius plot for the antioxidant compounds

Chapter 6

Summary and Conclusions

Rice bran, makes up approximately 10 % of rice milling fractions and is nutritionally rich with 16 –22% lipid, 12 –16 % protein, 8-12 % crude fiber and high levels of other vitamins and minerals (Saunders, 1990). The lipid fraction of rice bran contains nutritionally important antioxidant compounds, that include oryzanols, tocopherols and tocotrienols (Godber et al., 1994). These antioxidant compounds are beneficial in lowering cholesterol as well as preventing cardiovascular diseases (Lloyd et al., 2000). Tocopherols are also believed to have anticancer effects (Tarber and Packer, 1995; Dunford, 2001). Oryzanols lower harmful cholesterol (LDL) without reducing good cholesterol (HDL) (Nicolosi et al., 1992; Dunford, 2000). Organic solvent extraction is the conventional method for lipid recovery from rice bran, which uses highly toxic and highly flammable solvents and has problems of waste disposal and leaving toxic residues. The search for alternative, non-hazardous and environment-friendly extraction technique has lead to the emergence of supercritical fluid techniques for extraction related to food, pharmaceutical, nutraceutical and natural product industries. Carbon dioxide is the most widely used supercritical solvent (McHugh and Krukoni, 1994; King, 2000; Mukhopadhyay, 2000; Mohamed and Mansoori, 2002). Earlier studies have found supercritical extraction as more efficient extraction technique in comparison with solvent extraction of γ -oryzanol from rice bran (Xu and Godber,2000).

Rice husks (hulls) make up approximately 20% of the rice milling fraction and is widely used for energy generation in the rice milling industry. Rice husk ash (RHA) is an end product of the combustion of rice husk. RHA has good adsorbent properties because of its high silica content (Vellupillai et al., 1997). Apart from textile (Ahmed and Ram, 1992), food (Ahmedna et

al., 1997), pharmaceuticals (Jeyashoke et al., 1996 Janes et al., 1998) and waste water components, RHA has also been successfully applied as adsorbent for several lipid components such as phospholipid (Brown and Snyder, 1989), lutein (Proctor and Pallanippan, 1990), palmitic and oleic acids (Ooi and Leong, 1991), carotene (Liew et al., 1993) and saturated fatty acids (Farook and Ravendran, 2000).

In the present study, rice bran was extracted at the pilot scale with supercritical carbon dioxide with combined application of RHA adsorbent for extraction and adsorption of rice bran oil and its antioxidant compounds. The extraction conditions were varied by changing pressure (27.6, 41.4 and 55.2 MPa), flow (25, 45 and 65 g/min) and temperature (40 and 60 °C). Experiments were conducted with and without RHA adsorbent and extracts were collected at different time intervals (30, 60, 90, 120, 180, 240 min) during four hour extraction runs in a 3L pilot-scale supercritical fluid extractor with sample size of 750 g. Each experiment was replicated twice and the collected extracts were analyzed for oil weight. The sample taken from the extracts were then analyzed with normal phase HPLC using a WatersTM system with fluorescence and UV absorbance detection. Extraction of rice bran lipids with a conventional Soxhlet solvent extraction was also carried out for 6 hour using petroleum ether as a solvent. These solvent extracted samples of rice lipids were also analyzed for yield as well as concentration of antioxidant compounds.

The Goto et al. (1993) model in the form similar to that applied by Canela et al. (2002) for carotenoids extraction from microalgae was applied to the rice bran oil extraction data in the current experiments for mathematical representation of the extraction process. A separate batch study for adsorption of antioxidants from commercial rice bran oil was also conducted. RHA was used to adsorb antioxidant compounds from rice oil:hexane (20:80) miscellas. The initial ash weights (5, 10 and 20 g) and incubation temperatures (20, 30 and 40 °C) were varied with

constant agitation at 200 rpm. The samples were incubated with ash for different time intervals (30, 60, 90, 120 and 180 min) and samples collected after adsorptions were analyzed with HPLC to quantify the adsorption of the antioxidants. Freundlich adsorption isotherms were applied to the antioxidant adsorption data and the change in enthalpy values were calculated using the Van't Hoff-Arrhenius equation.

Total extract yield in the case of bran without ash experiments (17.26-18.52 %) as well as in the bran with ash experiments (17.35-18.99 %) for the extraction conditions of higher pressure (55.16 MPa) and flow rates (65 g/min) was comparable to that of solvent extractable oil yield (17.88 %). This indicated that supercritical carbon dioxide extraction was quantitatively competitive with conventional solvent extraction. Total extract yield significantly increased ($p < 0.05$) with an increase in pressure from 27.58 MPa to 55.16 MPa and an increase in flow rate from 25 g/min to 65 g/min in both sets of experiments (with ash and bran only experiments). Cumulative extract yield for both extraction experiments were significantly affected ($p < 0.05$) by pressure as well as flow rate. Increased solvent density and strength with pressure and an increase in convective mass transfer with increased flow rate could be responsible for these behaviors. Temperature effect on total extract yield, as well as cumulative extract yields, with time, did not show any specific trends and was not statistically significant ($p > 0.05$). Cross-over effect of temperature at a constant pressure, may have contributed to a temperature effect on extraction.

In the bran-only experiments, antioxidant extraction was significantly ($p < 0.05$) increased with an increase in pressure. This indicates that solubility of the antioxidant increased with increased solvent strength. The flow effect was not significant ($p > 0.05$) for antioxidants extraction, which shows that an increase in mass transfer rate does not contribute positively to antioxidant extractions. The pressure and flow effects were similar in the case of oryzanol,

tocopherols and tocotrienols. Temperature effect on extraction of antioxidant compounds varied over the studied extraction conditions as well as with type of antioxidant. Statistically there was no significant difference ($p > 0.05$) in antioxidants extraction due to temperature.

Concentration and yields of the antioxidants increased significantly ($p < 0.05$) with an increase in pressure for all three antioxidants in SFE with ash experiments. The effect of flow on antioxidants in rice bran oil for the experiments with ash was not significant ($p > 0.05$) and varied with antioxidant type and extraction conditions.

SFE extraction of total oil with ash was comparable to SFE bran only experiments under similar conditions. Moreover at higher pressure (55.16 MPa) and flow rate (65 g/min), SFE with ash also gave total oil yields (17.35-18.99 %) that were comparable with the Soxhlet extractions (17.88 %) using petroleum ether. Cumulative-yield graphs at different extraction conditions also indicated that SFE extraction with ash showed similar extraction behaviors with time compared to SFE bran-only experiments. Though there were minor observable differences in the oil yields with and without ash, the differences were not statistically significant ($p < 0.05$). These behaviors indicated that ash does not cause any major changes in the extraction pattern of the oil. However, antioxidants in the rice bran oil were significantly affected by ash adsorption. Oryzanol concentrations and yields were much higher in the extract for the with-ash experiment. This result could have occurred because oryzanol is a difficult compound to extract compared to other rice lipid constituents. Tocopherol extraction was significantly affected by ash adsorption. In the SFE bran-only experiments, tocopherol concentrations declined with time as extraction progressed. Whereas in the with-ash adsorption, since the ash was adsorbing the tocopherols, resultant extracts were lower in tocopherols initially, and increased over time as extraction progressed. Extraction behavior of tocotrienols in the with-ash and bran-only extractions were

similar to that of tocopherols. Structural similarity between tocopherols and tocotrienols could have contributed to this similar adsorption behavior with ash.

The Goto et al. (1993) model developed for extraction of essential oil was applied in the present study. The model successfully characterized extraction behavior for the bran-only experiment and values of the partition coefficient K and mass transfer coefficient K_p were calculated and reported. Since the results of the extraction behavior in combined extraction-adsorption applications in this study did not show any significant variation from extraction experiments with bran only in terms of the total extract yield, as well as cumulative extract yield behaviors, the Goto extraction model was applied to this combined SFE extraction and adsorption study in relation to extract yields. The Goto et al. (1993) model was able to accurately predict the extract yields in combined extraction-adsorption experiments for rice bran lipid under the experimental conditions. The resultant values of partition coefficient K and mass transfer coefficient K_p for bran-only and with-ash experiments were compared and did not differ significantly.

From the batch adsorption study with rice oil-hexane miscella, adsorbed amount increased for the first 30 minutes and then remained fairly constant for all three antioxidant compounds. Moreover, with time, adsorption behavior of tocopherols and tocotrienols were similar and their adsorption was higher compared to that of oryzanol. Experimental data were successfully fitted to the Freundlich equation and fitting parameters (k and $1/n$) were determined for each antioxidant. Values of k increased with increased temperature for oryzanol whereas for tocopherols and tocotrienols k values decreased with increased temperature. This indicated that adsorption of oryzanol was favorable at higher temperature whereas that of tocopherols and tocotrienols was favorable at lower temperatures. The k values were used to plot the Van't Hoff-Arrhenius and calculate enthalpy change value (ΔH). The positive values of the enthalpy change

for oryzanol indicated its adsorption process was endothermic, whereas negative values of ΔH for tocopherols and tocotrienols indicated their process to be exothermic. This batch adsorption study also indicates the differences in adsorption behavior for oryzanol compared to tocopherols and tocotrienols.

References

- Achife, E.C., and Ibemesi, J.A. 1989. Applicability of Freundlich and Langmuir isotherms in bleaching of rubber and melon seed oils. *J. Am. Oil Chem. Soc.* 66(2): 247-52.
- Ahmed, M.N., and Ram, R.M. 1992. Removal of basic dye from wastewater using silica as adsorbent. *Environmental Pollution*. 77:79-86.
- Ahmedna, M., Johns, M.M., Clarke, S. J., Marshall, W.E., and Rao, R. M 1997. Potential of agricultural by-product based activated carbons for use in raw sugar decolorization. *J. Sci. Food. Agric.* 75: 117- 124.
- Ahmedna, M., Marshall, W.E., and Rao, R.M. 2000. Production of granular activated carbons from select agricultural by-products and evaluation of their physical, chemical and adsorption properties. *Bioresource Technol.* 71:113-123.
- Akgun, M., Akgun, N.A., and Dincer, S. 2000. Extraction and modeling of lavender flower essential oil using supercritical carbon dioxide. *Ind. Eng. Chem. Res.* 39(2): 473-477
- Ambrosino, P., Fresa, R., Fogliano, V., Monti, S.M., and Ritieni, A. 1999. Extraction of azadirachtin-A from neem seed kernels by supercritical fluid and its evaluation by HPLC and LC/MS. *J. Agric. Food. Chem.* 47:5252-5256.
- Augilera, J.M., and Stanley, D.W. 1990. Micro structural principles of food processing engineering. In *Solid liquid extraction*. eds. Augilera J.M. and Stanley D.W. Elsevier Applied Science, New York. p 236-290.
- Awasthy, A., and Trivedi, R.K. 1997. A review on supercritical extraction of natural products. *Chemical Engineering World*. <http://exicom.org/cew/oct97/awasthi.htm> asp June 20, 2001
- Badal, R. 2002. Supercritical carbon dioxide extraction of lipids from raw and bio-converted rice bran. Thesis at Louisiana State University, Baton Rouge.
- Baldwin, A.R.1948. Effects of deodorization on the stability of vegetable oils *J. Am. Oil Chem. Soc.* 25(2): 33-35.
- Barber, S., and Barber, C. 1980. Rice Bran: chemistry and technology. In *Rice: Production and Utilization*. ed. Luh B. S. AVI publishing Co. Inc. ,Westport, CT. p 791
- Beagle, E.C.1978. Rice husk: conversion to energy, FAO report. pp123-34.
- Bhaskar, A.R., Rizvi, S.S.H., and Sherbon, J.W. 1993. Anhydrous milk fat fractionation with continuous counter current supercritical carbon dioxide. *J. Food Sci.* 58:748-
- Bhattacharya, A.C., Majmudar, S. and Bhattacharya, D.K. 1986. Edible quality rice bran oil from high FFA rice bran oil by miscella refining. *J. Am. Oil Chem. Soc.* 63(9): 1189-1191.

- Bhattacharya, D.K., Chakrabarty, N.M, and Vaidyanathan, R.S. 1983. A Critical study of refining of rice bran oil. *J. Am. Oil Chem. Soc.* 60(2): 466.
- Bhattacharya, S., and Bhattacharya, D.K. 1987. Deacidification of high FFA rice bran oil by reesterification and alkali neutralization. *J. Am. Oil Chem. Soc.* 64(1): 128-31.
- Bhattacharya, S and Bhattacharya, D.K. 1989. Biorefining of high acid rice bran oil. *J. Am. Oil Chem. Soc.* 66(12): 1809-11.
- Bjergegaard, C., Buskov, S., Sorensen, H., Sorensen, J.C., and Sorensen, S. 1999. Supercritical fluid techniques as preparative and analytical tools in the analytical gray area between volatiles and hydrophilic compounds. Proceedings of 10th international rapeseed congress, Canberra Australia.
- Bourgeois, C. 1992. Introduction Ch.1. In *Determination of Vitamin E: Tocopherols and Tocotrienols*. ed. Bourgeois C., Elsevier Science Publishers Ltd., New York. p 1-7.
- Brown, H.G., and Snyder H.E. 1985. Adsorption of soya oil phospholipid on silica. *J. Am. Oil Chem. Soc.* 62(4): 753-56.
- Brown, H.G. and Snyder, H.E. 1989. Factors affecting phospholipid adsorption on silica from soya oil miscella. *J. Am. Oil Chem. Soc.* 66(3): 353- 355.
- Brunetti, L., Daghett, A., Fedeli, E., Kikic, I., and Zanderighi, L. 1989. Deacidification of olive oils by supercritical carbon dioxide. *J. Am. Oil Chem. Soc.* 66 (2): 209-217
- Brunner, G. 1984. Mass transfer from solid material in gas extraction. *Ber. Bunsenges. Phys. Chem.* 88:887-91.
- Budavari, S., O'Neil, M.J., Smith, A., and Heckelman, P.E. eds. 1989. The Merck Index 11th ed. Merck & Co. Inc., Rahway, New Jersey.
- Bulley, N.R., and Fattori, M. 1984. Supercritical fluid extraction of vegetable oil seeds. *J. Am. Oil Chem. Soc.* 61(8): 1362-65.
- Canela, A.P.R.F., Rosu, P.T.V., Maraques, M.O.M., and Meireles M.A.A. 2002. Supercritical extraction of fatty acids and carotenoids from microalgae *sporulina maxima*. *Ind. Eng. Chem. Res.* 41: 3012-3018.
- Champagne, E.T., and Hron, Sr. R.J. 1992. Stability of ethanol extracted brown rice to hydrolytic and oxidative deterioration. *J. Food Sci.* 57(2): 433-36.
- Chang, Y. Y., Lin, C. I., and Chen, H. K. 2001. Effect of acid activation on sesame oil bleaching by rice hull ash. *J. Chem. Eng. of Japan.* 34 (1): 1-6.

- Chase, G.W. jr., Akoh, C.C., and Eitenimiller, R.R. 1994. Analysis of tocopherols in vegetable oils by high pressure liquid chromatography: comparison of fluorescence and evaporative light scattering detection. *J. Am. Oil Chem. Soc.* 71: 877-880.
- Chen, C.Y., Lin, C.I., and Chen, H.K. 2003. Kinetics of adsorption of β -carotene from soy oil with activated rice hull ash. *J. Chem. Eng. of Japan.* 36(3): 265-270.
- Chen, Y., and Ling, Y. 2000. An Overview of supercritical fluid extraction in Chinese herbal medicine: from preparation to analysis. *J. Food and Drug Anal.* 8(4): 235-247.
- Chester, T.L., Pinktson, J.D., and Raynie, D.E. 1998. Supercritical fluid chromatography and extraction. *Anal. Chem.* 70(12): 301R-19R.
- Cheung, P.C.K., Leung, A.Y.H., and Ang, P.O. Jr. 1998. Comparison of supercritical carbon dioxide and Soxhlet extraction of lipids from a brown seaweed. *J. Agric. Food Chem.* 46: 4228-32.
- Chou, K.S., Tsai, J.C., and Lo, C.T. 2001. The adsorption of congo red and vacuum pump oil by rice hull ash. *Bioresour. Technol.* 78(2): 217-19.
- Clifford, T. 1999. Fundamentals of supercritical Fluids. Oxford University Press Inc., New York. p203.
- Clifford, A.A. and Williams, J.R. 2000. Introduction to supercritical fluids and their applications. In *Super Critical Fluids: Methods and Protocols.* ed. Williams J.R. and Clifford A.A., Humana press, Totowa, New Jersey. pp 1-16
- Cook, D.J., and Suwanvitaya, P. 1981. Rice husk ash based cements- a state of art review Proc. UNIDO/ ESCAP/RCTT Third workshop on rice husk ash cements New Delhi India.
- Crank, J. 1975. The Mathematics of diffusion. Oxford Clarendon Press.
- Cross, W.M., and Akgerman, A. 1998. Adsorptive separations using supercritical frontal analysis chromatography. *AIChE Journal.* 44(7): 1542-1554.
- Danaher, M., and O'keeffe, M. 2002. Extracting residues of contaminants from food with supercritical carbon dioxide. *Food Technology.*
- Decastro, M.D.L., and Carmona M.M.J. 2000. Where supercritical fluid extraction is going. *Trends in Anal. Chem.* 19(4): 223-228.
- DeDecker, E.A.M., and Korver, O. 1996. Minor constituents of rice bran oil as functional foods. *Nut. Rev.* 54: S120-S126.
- DeSouza, M.F., Batista, P.S., Regiani, I., Liborio, J.B.L., and DeSouza, D.P.F. 2000. Rice hull derived silica : Applications in portland cement and multiple whiskers. *Mater. Res.* 3(2):25-30.

- Diack, M., and Saska, M. 1994. Separation of vitamin E and γ -oryzanol from rice bran by normal phase chromatography. *J. Am. Oil Chem. Soc.* 71 (11): 1211-17.
- Dunford, N.T. 2001. Health benefits and processing of lipid based nutritional. *Food Technology* 55(11):38-43.
- Dunford, N.T., Tee, J.A. and King, J.W. 2003. A continuous counter current supercritical fluid deacidification process for phytosterol ester fortification in rice bran oil. *Food Res. Int.* 36(2): 175-181.
- Dunford, N.T., and King, J.W. 2000. Phytosterol enrichment of rice bran oil by a supercritical carbon dioxide fractionation technique. *J. Food Sci.* 65(8):1395-99.
- Duve, J.K. and White, P.J. 1991. Extraction and identification of antioxidants in oats. *J. Am. Oil Chem. Soc.* 68:365.
- Dziedzic, J.D. 1986. Innovative separation process finding its way in to the food industry. *Food Technology*. June: 66-69.
- Eggers, R., and Sievers, U. 1989. Processing of oil seed with supercritical carbon dioxide. *J. Chem. Eng. of Japan.* 22(6):641-649.
- Egger, R. 1996. Supercritical extraction of oilseeds /lipids in natural products. In *Supercritical Fluid Technology in Oil and Lipid Technology*. eds. King J.W. and List G.R. AOCS Press. Champaign, Illinois. p428.
- Economic Research Service (ERS). 2004. Briefing: Rice. USDA. <http://www.ers.usda.gov/briefing/rice/>. asp July 20, 2004
- Eller, F. J. 2002. Supercritical carbon dioxide extraction of fat. *Food Technology* <http://www.wmrc.com/businessbriefing/pdf/foodtech2002/publication/eller.pdf> asp December 20, 2002.
- Eugenia, G.P., and Danielle, B. 2001. Supercritical fluid extraction of Z-sabinene hydrate rich essential oil from Romanian Mentha hybrids. *Pure Appl. Chem.* 73(8):1287-91.
- Farook, A., and Ravendran, S. 2000. Saturated fatty acid adsorption by acidified rice hull ash, *J. Am. Oil Chem. Soc.* 77 (4): 437-40.
- Farrall, A.W. ed. 1979. Dictionary of agricultural and food engineering. The Interstate Prin. Pub. Inc. Davville, IL.
- Fattori, M., Bulley, N. R. and Meisen, A. 1988. Carbon dioxide extraction of canola seed: oil solubility and effect of seed treatment. *J. Am. Oil Chem. Soc.* 65(6): 968-74.
- Favati, F., King, J.W., and Mazzanti, M. 1991. Supercritical carbon dioxide extraction of evening primrose oil. *J. Am. Oil Chem. Soc.* 68(6): 422-27.

- Friedrich, J.P. and Pryde, E.H. 1984. Supercritical CO₂ extraction of lipid bearing materials and characterization of products. *J. Am. Oil Chem. Soc.* 61(2): 223-228.
- Froning, G.W., Wehling R.L., Cuppett S.L., Pierce, M.M., Niemann L. and Siekman, D.K. 1990. Extraction of cholesterol and other lipids from dried egg yolk using supercritical carbon dioxide. *J. Food Sci.* 55:85-
- Fujino, Y. 1978. Rice lipids. *Cereal Chem.* 55(5):559-71.
- Galan, M.J., Nienaber, U., and Schwartz, S. 1999. Paprika oleoresin extraction with supercritical carbon dioxide. *J. Agric. Food Chem.* 47(9):3558-64.
- Garcia, A., Lucas, A., Rincon, J., Alvarez, A., Garcia, I., and Garcia, M.A. 1996. Supercritical extraction of fatty and waxy material from rice bran *J. Am. Oil Chem. Soc.* 73(9):1127-31.
- Gimeno, E., Calero, E., Castellote, A.I., Lamuela, R.R.M., Torre, M.C. and Sabater, M.C L.. 2000. Rapid determination of vitamin E in vegetable oils by reverse phase high performance liquid chromatography. *J. Chromatography A.* 881:251-54.
- Godber, J.S., Martin, D., Shin, T.S., Setlhako, G., Tricon, C., and Gervais, M. 1993. Quality parameters important in rice bran for human consumption. *Louisiana Agriculture* 36(3):9-12.
- Godber, J.S., Shin, T.S., Saska, M. and Wells, J.H. 1994. Rice bran: as a viable source of high value chemicals. *Louisiana Agriculture* 37(2):13-
- Goodarznia, I., and Eikani, M.H. 1998. Supercritical carbon dioxide extraction of essential oils : modeling and simulation. *Chem. Eng. Sci.* 53(7):1387-95.
- Goodrum, J.W., Kilgo, M.K., and Santerre, C.R. 1996. Oil seed Solubility and extraction modeling In *Supercritical Fluid Technology in Oil and Lipid Technology*. eds. King J.W and List G.R., AOCS Press. Champaign, Illinois
- Goodwin, J.D., and Mulkey, F.W. 1986. Sorbant and process using rice hull ash compositions . US Patent no. 4,571,389.
- Gopala Krishna, A.G. 1993. Influence of viscosity on wax settling and refining loss in rice bran oil. *J. Am. Oil. Chem. Soc.* 70 (9): 895-898.
- Gopal Krishna, A.G., Prabhakar, J.V., and Sen D.P. 1984. Effect of degree of milling on tocopherol content of rice bran. *J. Food Sci. and Techno.* 21: 222-24.
- Gopala Krishana, A.K. 1992. A method for bleaching rice bran oil with silica gel. *J. Am. Oil. Chem. Soc.* 69 (12): 1257-59.
- Goto, M., Sato, M., and Hirose, T. 1993. Extraction of perremint oil by supercritical carbon dioxide. *J. Chem. Eng. of Japan.* 26 (4): 401-407

- Govind Rao, V.M.H. 1980. Utilization of rice husk - a preliminary analysis *J. Scientific Ind. Res.*, 39 Sept: 495 –515.
- Graboski, M., and Bain, R. 1979. Properties of biomass relevant to gasification. *In* A survey of biomass Gasification. Solar Energy Res. Institute. Volume II – principles of gasification, Ch.-3., Colorado School of mines II26-27-30-33.
- Graci, A. Jr, Reuther, C.G.H., Eaves, P.H., Molaison, L.J., and Spadaro, J.J. 1953. Pilot plant application of filtration –extraction to rice bran. *J. Am. Oil. Chem. Soc.* 30(4):139-143.
- Gregg, S. J., and Sing, K.S.W. 1982. Adsorption, surface area and porosity. Academic press, London.
- Greyt, W.D., and Kellens, M. 2000. Refining practices. *In* *Edible oil processing*. Hamm W. and Hamilton R. J. eds. Sheffield Academic Press, Boca Raton, FL
- Hamad, M. A., and Khattab, I.A. 1981. Effect of the combustion process on the structure of rice hull silica. *Thermochim. Acta.* 48(3): 343-9.
- Hargrove, Jr. K.L. 1994. Processing and Utilization of rice bran in the United States. *In* *Rice Science and Technology*. Marshall W.E .and Wadsworth J.I. eds. Marcel Decker , Inc., New York. p 381-404
- Hemavathy, J. and Prabhakar, J.V. 1987. Lipid composition of rice bran. *J. Am. Oil Chem. Soc.* 64 (7):1016-19.
- Houston, D.F.1972. Rice bran and polish. *In* *Rice Chemistry and Technology*, Houston D.F. ed. American Association of Cereal Chemists, St. Paul, Minnesota.
- Hu, W.1995. Production of an enriched tocopherol, tocotrienol, oryzanol fraction from extrusion stabilized rice bran. Louisiana State University. M.S. Thesis.
- Hua, Na. 2000. Fourier transform infrared spectroscopy determination of gamma-oryzanol and vitamin E in rice bran. Louisiana State University. M.S. Thesis.
- Huseyin, T., and Uksel, Y. 1999. Investigation of adsorption isotherms of myristic , palmitic and stearic acids on ric hull ash. *Turk J. Chem.* 23(2): 93-98.
- Ibqnez, E., Oca, A., Murga, G., Sebastian, S. L., Tabera, J., and Reglero, G. 1999. Supercritical fluid extraction and fractionation of different preprocessed rosemary plants. *J. Agric. Food. Chem.* 47: 1400- 1404.
- Idris, S.M. and Farook, A. 1994. Adsorption isotherms of free fatty acids on rice hull ash in a model system. *J. Am. Oil Chem. Soc.* 71(12): 1363-66.

Imision, B., and Unthank, D. 2000. Adding value to essential oils and other natural ingredients. A report for Rural Industry Research and Development Corporation of Australia. RIRDC publication no 00/40. pp 46.

IRRI. 2003. Rice husk or hull properties. International Rice research Institute knowledge bank http://www.knowledgebank.irri.org/troprice/Rice_Hull_or_Husks.htm July 21, 2003

Janes, M.E., Nannapaneni, R., Proctor, A., and Johnson, M.G. 1998. Rice hull ash and silicic acid as adsorbents for concentration of bacteriocins. *Appl. Environ. Microbiol.* 64(11): 4403-09.

James, J., and Subba Rao, M. 1986. Characterization of silica in rice husk ash, *American Ceramic Society Bulletin.* 65(8) 1177-80.

Jeyashoke, N., Tantrakoonsiri, C. and Krisnangura, K. 1996. Protein adsorption by rice hull ash. *Microb. Util. Renewable Resour.* 9:545-48.

Johson, L.A., and Lusas, E.W. 1983. Comparison of alternative solvents for oils extraction. *J. Am. Oil. Chem. Soc.* 60(2): 229-42.

Jorge, T.V., Guadalupe, M.M., and Miriam, A. 2000. Adsorption efficiency of selected adsorbents in sesame oil miscellas. *J. Food Lipids.* 7 (3) 151-62.

Juliano, B.O. 1985. Rice Chemistry and Technology, American Association of Cereal Chemists, St. Paul, Minnesota

Kalapathy, U., Proctor A. and Shultz J. 2000. A simple method for production of pure silica from rice hull ash. *Bioresource Technol.* 73(3) :275-62.

Kalapathy, U., Proctor A. and Shultz, J. 2002. An improved method for production of silica from rice hull ash. *Bioresource Technol.* 85:285-89.

Kamath, S.R. and Proctor, A. 1998. Silica gel from rice hull ash: preparation and characterization. *Cereal Chem.* 75(4) 484 – 68.

Kao, C. and Luh, B.S. 1991. In *Rice: Vol.2.* Luh B. S. ed. Avi New York. p295-311

Kim, C.J., Byun, S.M., Cheigh, H.S., and Kwon, T.W. 1987. Comparison of solvent extraction characteristics of rice bran pretreated by hot air drying, steam cooking and extrusion. *J. Am. Oil. Chem. Soc.* 64(4):514-16.

Kim, H. J., Lee, S.B., Park, K.A., and Hong, I.K. 1999. Characterization of extraction and separation of rice bran oil rich in EFA using SFE process. *Separation and purification technology* 15:1-8.

Kim, S.K., Kim, C.J., and Cheigh, H.S. 1985. Effect of caustic refining, solvent refining and steam refining on the deacidification and color of rice bran oil. *J. Am. Oil. Chem. Soc.* 62(10): 1492-95.

- King, J.W., and List, G.R., ed. 1996. Supercritical fluid technology in oil and lipid technology. AOCS Press. Champaign, Illinois.
- King, J.W. 2000. Sub and supercritical fluid processing of agrimaterials: extraction, fractionation and reaction modes. *In Supercritical fluid engineering science: fundamentals and applications.* Krian E. and Brennecke J. F. ed. ACS symposium series. American chemical society. Washington, DC
- Kiran, E., and Brennecke, J.F., eds. 1993. Supercritical Fluid Engineering Science: Fundamentals and Applications. ACS symposium series. American chemical society. Washington, DC
- Kiran, E., Pablo, G.D., and Peters, C.J., eds. 2000. Supercritical fluids: Fundamentals and Applications. Kluwer Academic Publishers. Dordrecht, Netherland.
- Klesper, E., 1980. Chromatography with supercritical fluids *In Extraction with Supercritical Gases.* Schneider G.M., Stahl E. and Wilke G., ed. Verlag, Weinheim, Germany
- Komiyama, K., Hayash, M., Cha, S., and Yamaoka, M. 1992. Antitumor and antioxidant activity of tocotrienols. *In Lipid Soluble Antioxidants: Biochemistry and Clinical Applications.* Ong ASH and Packer L. eds. Birkhauser Verlag :Basel, Switzerland p 152-159
- Krukronis, V.J. 1988. Processing with supercritical fluids. *In Supercritical Fluid Extraction and Chromatography.* Charpetier B.A. and Sevenants M.R., eds. American Chemical Society, Washington, DC pp:26-43
- Kuk, M.S., and Dowd, M.K. 1998. Supercritical extraction of rice bran. *J. Am. Oil. Chem. Soc.* 75 (5): 623-628.
- Lakkakula, N. R., Lima, M., and Walker, T. 2004. Rice bran stabilization and rice bran oil extraction using ohmic heating. *Bioresource Technol.* 92: 157-161
- Lang, Q. and Wai, C. 2001. Supercritical fluid extraction in herbal and natural product studies- a practical review. *Talanta* 53: 771-782.
- Lee, W.Y., Cho, Y.J., Oh, S.L., Park, J.H., Cha, W.S., Jung, J.Y., and Choi, Y.H. 2000. Extraction of grape seed oil by supercritical CO₂ and ethanol modifier. *Food Sci. Biotechnol.* 9(3): 174-78.
- Liew, K.Y., Yee, A.H, and Nordin, M.R. 1993. Adsorption of carotene from palm oil by acid treated rice hull ash. *J. Am. Oil. Chem. Soc.* 70(5):539-41.
- Lin, S.P., Lin, C.I., and Chen, H.K. 2001. Sesame oil bleaching with activated rice hull ash. *J. Chem. Eng. of Japan.* 34(6): 737-42.
- Lira, C.T. 1996. Thermodynamics of supercritical fluids with respect to lipid containing systems. *In Supercritical Fluid Technology in oil and lipid Technology.* King J.W., and List G.R.. ed. 1996. AOCS Press. Champaign, Illinois.

- List, G.R., King, J.W., Jhonson, J.H., Warner, K., and Mounts, T.L. 1993. Supercritical CO₂ degumming and physical refining of soybean oil. *J. Am. Oil. Chem. Soc.* 70:473.
- Llyod, B.J., Sibernmorgen, T.J., and Beers, K.W. 2000. Effect of commercial processing on antioxidants in rice bran. *Cereal Chem.* 77(5): 551-555.
- Louisiana Summary. 2002. Louisiana Agriculture Summary. LSU Agriculture Center.
- Luh, B.S. 1980. Rice: Production and utilization. The AVI Publishing Company Inc. p 736-63.
- Luh, B.S. ed. 1991. Rice: Utilization, Vol-2. Nostrand Reinhold p 295 – 365.
- Malekian, F. 1992. Functional, nutritional and storage characteristics of rice bran as affected by microwave heat and extrusion stabilization methods. Louisiana State University. MS Thesis.
- Mamipitiyarachchi, T.R. 1981. Use of rice hull ash in water treatment. *Dissertation Abstract International*. Vol 4-08B P: 2505 No: AAI 0552782.
- Manninen, P., Pakarinen, J., and Heikki, K. 1997. Large-scale supercritical carbon dioxide extraction and supercritical carbon dioxide counter current extraction of cloudberry seed oil. *J. Agric. Food Chem.* 45:2533-38.
- Marrone, C., Poletto, M., Reverchon, E., and Stassi, A. 1998. Almond oil extraction by supercritical CO₂ : experiments and modeling . *Chem. Eng. Sci.* 53(21): 3711-18.
- Martin, A.A., and Aydin, K.S.eds. 1996. Supercritical fluids: extraction and pollution prevention. ACS symposium series. American Chemical society, Washington, DC.
- Martin, D.E. 1994. Extrusion Stabilization and near infrared analysis of rice bran. Louisiana State University. M.S. Thesis.
- Maxell, R.J. 1996. Solubilty measurements of lipid components in the supercritical fluids. In *Supercritical Fluid Technology in POil and Lipid Technology*. King J.W. and List G. R. ed. AOCS Press. Champaign, Illinois.
- Mccabe, W.L., and Harriott, P. and Smith, J.C. 2005. Unit operations of chemical engineering McGraw Hill Chemical Engineering Sieries.
- McCaskill, D.R .and Zhang, F. 1999. Use of rice bran oil in foods. *Food Technology* 53 (2): 50 –
- Mc Huahg, M., and Krukonis, V. 1994. Supercritical fluid extraction: principles and practices. 2nd ed. Butterworth -Heineman, Newton, MA.
- Mehta, P.K and Pitt, N. 1976. Energy and industrial materials from crop residues. *Resource recovery and Conversion* 2: 23-28

- Meinke, W.W., Holland, B.R., and Harris, W.D. 1949. Solvent extraction of rice bran. Production of B-vitamin concentrate and oil by isopropanol extraction. *J. Am. Oil. Chem. Soc.* 26(10): 532-34.
- Mishra, A., Gopal Krishna, A.G., and Prabhakar, J.V. 1988. Factors affecting refining losses in rice bran oil. *J. Am. Oil. Chem. Soc.* 65(10):1605- 09.
- Mohamed, R.S., and Mansoori, G.A. 2002. The use of Supercritical fluid extraction technology in Food Processing. *Food Technology*. WMRC June.
- Montanrai, L., King, J.W., List G.R., and Rennick, K.A. 1996. Selective extraction of phospholipid mixtures by supercritical carbon dioxide and co solvents. *J. Food Sci.* 61 (6): 1230-33.
- Moreau, R.A., Powell, M.J., and Hicks, K.B. 1996. Extraction and quantitative analysis of oil from corn fiber. *J. Agric. Food Chem.* 44: 2149-54.
- Morgan, A., Shaw, D.B., Sidebottom, M.J., Soon, T.C., and Taylor, R.S. 1985. The function of bleaching earth in processing of palm, palm kernel and coconut oils. *J. Am. Oil. Chem. Soc.* 62 (2): 292-99.
- Morton, R.A. 1975. *Biochemical Spectroscopy*. Vol.2 Wiley and Sons. New York.
- Motonobu, G, Masaki, S and Tsutomu, H. 1993. Extraction of peppermint oil by supercritical carbon dioxide. *J. Chem. Eng. of Japan.* 26(4): 401-7.
- Mukhopadhyay, M. 2000. *Natural Extracts Using supercritical Carbon dioxide*. CRC press. Boca Raton, FL. p327.
- Nakbanpote, W., Thiravetyan, P., and Kalambaheti, C. 2000. Preconcentration of gold by rice husk ash. *Miner. Eng.* 13(4): 391-400.
- Nasirullah, M.N., Krishnamurthy, and Nagraja, K.V. 1989. Effect of stabilization on the quality characteristics of rice bran oil. *J. Am. Oil. Chem. Soc.* 66(5):661-63.
- Nesartetnam, K., Stephen, R., Dils, R., and Darbe, P. 1998. Tocotrienols inhibit the growth of human breast cancer cells irrespective of estrogen receptor status. *Lipids.* 33:461-69.
- Nguyen, U.Y., Anstee, M., and Evans, D.A. 1998. Extraction and fractionation of spices using supercritical carbon dioxide. Paper presented at 5th International Symposium on supercritical Fluids 1998 Nice. France.
- Nicolosi, R.J., Rogers, E.J., Austman, L. M. and Orthoefer, F.T. 1994. Rice bran oil and its health benefits. *In Rice Science and Technology*. Marshall W and Wadsworth J. I. Marcel Dekker Inc., New York p 421-437.

- Nilsson, W.B., Gauglitz, E.J. Jr., Hudson, J.K., Stout, V.F. and Spinelli, J. 1988. Fractionation of menhaden oil ethyl esters using supercritical CO₂. *J. Am. Oil. Chem. Soc.* 65(1): 109-17.
- Nutrient Database.2002.USDA NDB No: 20060 & 4037 . http://www.nal.usda.gov/fnic/cgi-bin/list_nut.pl April 25, 2002
- Okada, T., and Yamaguchi, N. 1983. Antioxidant effect and pharmacology of oryzanol. *Yukagaku* 32:305-310
- Ooi, T.L. and Leong, W.L. 1991. Adsorption of palm oil monoglycerides using rice husk ash. *Elaeis* 3(1): 317-23.
- Orthofer, F.T.1996.Rice Bran Oil: Healthy lipid Source. *Food Technology*.December: 62-64.
- Orhofer, F.T., and Nicolosi, R.J. 1993. Rice bran oil composition and characteristics. Presented at 84th American Oil Chemists Society Annual meeting, Anaheim, California. April 25 -29.
- Ozer, E.O., Platin, S., Akman, U., and Hortacsu, O. 1996. Supercritical carbon dioxide extraction of spearmint oil from mint plant leaves. *The Canadian j. Chem. Eng.* 74:920-28.
- Palanippan, S., and Proctor, A. 1990. Competitive adsorption of lutein from soy oil on to the rice hull ash. *J. Am. Oil. Chem. Soc.* 67(9): 572-75.
- Palazoglu, T.K., and Balaban, M.O. 1998. Supercritical CO₂ Extraction of lipids from roasted pistachio nuts. *Trans. ASAE.* 44(3):670-84.
- Pandya, K.K., Prasad, G., and Singh, V.N. 1985. Copper (II) removal from aqueous solution by fly ash. *Water Resource.* 19 (7): 867-73.
- Paprier, E. 2000. Adsorption on silica surfaces. Surfactant Science Series V. 90. Marcel Dekker Inc., New York.
- Paulaties, M.E., Penninger, J.M.L., Gray, R.D. Jr., and Davidson, P., eds. 1983. Chemical Engineering at Supercritical Conditions. Ann Arbor Science Publishers, Ann arbor, Michigan p533.
- Peker, H., Srinivasan, M.P., Smith, J.M., and McCoy, B.J. 1992. Caffeine extraction rates from Coffee beans with supercritical carbon dioxide. *AIChE Journal* .38(5):761-70.
- Peng, D.Y., and Robinson, D.B. 1976 A new constant equation of state. *Ind. Eng. Chem. Fund.* 15 (1):59-
- Perrut, M., Calvier, J.Y., Poletto, M., and Reverchon, E. 1997. Mathematical modeling of sunflower seed extraction by supercritical CO₂. *Ind. Eng. Chem. Res.* 36(2): 430-35.
- Peter, S.1996. Supercritical fractionation of lipids. *In Supercritical Fluid Technology in oil and lipid Technology.* King J.W., and List G.R..ed. AOCS Press. Champaign, Illinois.

- Poletto, M., and Reverchon, E. 1996. Comparison of models for supercritical extraction of seed and essential oil in relation to the mass transfer rate. *Ind. Eng. Chem. Res.* 35(10):3680-86.
- Prabhakar, J.V., and Venkatesh, K.V.L. 1986. A simple chemical method for stabilization of rice bran. *J. Am. Oil. Chem. Soc.* 63(5): 644-46.
- Prieto, M.S. G., Caja, M. M., Herraiz, M., and Maria, G. S. 2003. Supercritical fluid extraction of all-trans-lycopene from tomato. *J. Agric. Food. Chem.* 51:3-7.
- Proctor, A. 1990. X ray diffraction electron microscope studies of processed rice hull silica. *J. Am. Oil. Chem. Soc.* 67 (9): 576-84.
- Proctor, A. and Bowen, D.J. 1996. Ambient temperature extraction of rice bran oil with hexane and isopropanol. *J. Am. Oil. Chem. Soc.* 73(6): 811-13.
- Proctor, A., Clark, P.K. and Parker, C.A. 1995. Rice hull ash adsorbent performance under commercial soy oil bleaching conditions. *J. Am. Oil. Chem. Soc.* 72 (4) :459-62.
- Proctor, A., Jackson, V.M., Scott, M., and Clark, P.K. 1994. Rapid equilibrium extraction of rice bran oil at ambient temperature. *J. Am. Oil. Chem. Soc.* 71(11):1295-96
- Proctor, A., and Palaniappan, S.1989. Soy oil lutein adsorption by rice hull ash, *J. Am. Oil. Chem. Soc.* 66 (11) 1618-21.
- Proctor, A., and Palaniappan, S. 1990. Adsorption of soy oil free fatty acids by rice hull ash. *J. Am. Oil. Chem. Soc.* 67 (1): 15-17.
- Proctor, A., and Snyder, H.E. 1987. Adsorption of lutein from soybean oil on silicic acid –I Isotherms. *J. Am. Oil. Chem. Soc.* 64(8):1163- 1166
- Proctor, A., Tan „S., and, Palaniappan, S. 1992. Phospholipid adsorption on to rice hull ash from soy oil miscellas. *J. Am. Oil. Chem. Soc.* 69 (10): 1049-50.
- Ramezanzadeh, F.M., Rao, R.M., Prinyawiwatkul, W., Marshall, W.E. and Windhauser, M. 2000. Effects of microwave heat packaging and storage temperature on fatty acid and proximate compositions in rice bran. *J. Agric. Food Chem.* 48(2):464-67.
- Ramsay, M. E., Hsu, J.T., Novak, R.A., and Reghtler, W.J. 1991. Processing rice bran by supercritical fluid extraction. *Food Technology*. November: 98-104.
- Randall, J.M., Sayre, R.N., Schultz, W.G., Fong, R.Y., Mossan, A.P., Tribelhorn, R.E. and Saunders, R.M. 1985. Rice bran stabilization by extrusion cooking for extraction of edible oil. *J. Food Sci.* 50(2): 361-64,368.
- Reddi, P.B., Murti, K.S., and Feuge, R.O.1948. Rice bran oil I: Oil obtained by solvent extraction. *J. Am. Oil. Chem. Soc.* 25(6): 206-11.

- Reventos, M., Duarte, S., and Alarcon, R. 2002. Application possibilities of supercritical CO₂ extraction in Food Processing Industry: An Overview. *Food Sci. Tech. Int.* 8(5): 269-84.
- Reverchon, E. 1996. Mathematical modeling of supercritical extraction of sage oil. *AIChE Journal* 42(6): 1765-71.
- Reverchon, E., Daghero, J., Marrone, C., Mattea, M., and Poletto, M. 1999. *Ind. Eng. Chem. Res.* 38:3069-75.
- Reverchon, E., and Iacuzio, G. 1997. Supercritical desorption of bergamot peel oil from silica gel – experiments and mathematical modeling. *Chem. Eng. Sci.* 52(20): 3553-3559.
- Reverchon, E., Kaziunas, A., and Marraone, C. 2000. Supercritical CO₂ extraction of hiprose seed oil: experiments and mathematical modeling. *Chem. Eng. Sci.* 55: 2195-2201.
- Reverchon, E., Lamberti, G., and Subra, P. 1998. Modeling and simulation of the supercritical adsorption of complex terpene mixtures. *Chem. Eng. Sci.* 53(20):3537-3544
- Reverchon, E., and Osseo, L.S. 1994. Comparison of process for supercritical carbon dioxide extraction of oil from soybean seeds. *J. Am. Oil. Chem. Soc.* 71(9): 1007-12.
- Reverchon, E., and Porta, G.D. 1995. Supercritical extraction and fractionation of lavender essential oil and waxes. *J. Agric. Food Chem.* 43:1654-58.
- Rhee, J.S., and Yoon, H.H.N. 1984. Stabilization of rice bran by microwave energy. *Korean J. Food Sci. and Techno.* 16(1):113-19.
- Rizvi, S.S.H. ed. 1994. Supercritical fluid processing of food and Biomaterials. Blackie Academic and Professional. Glasgow NZ.
- Rizvi, S.S.H., Chao, R.R., and Liaw, Y.J. 1988. Concentration of omega-3 fatty acids from fish oil using supercritical carbon dioxide. In *Supercritical Fluid Extraction and Chromatography* Charpetier B.A. and Sevenants M.R. eds. American Chemical Society, Washington, DC pp:26-43
- Rogers, E.J., Rice, E.M., Nicolosi, R.J., Carpenter, D.R., McClelland, C.A., and Romanczyk, L.J. Jr. 1993. Identification and quantification of γ -oryzanol components and simultaneous assessment of tocopherols in rice bran oil. *J. Am. Oil. Chem. Soc.* 70 (3): 601-07.
- Rong, N., Ausman, L.M. and Nicolosi, R.J. 1997. Oryzanol decreases cholesterol absorption and aortic fatty streaks in hamsters. *Lipids* 32:303-09
- Roy, B.C., Goto, M., and Hirose, T. 1996. Extraction of ginger oil with supercritical carbon dioxide : Experiments and modeling. *Ind. Eng. Chem. Res.* 35:607-12.
- Rozzi, N.L., and Singh, R.K.. 2002. Supercritical fluids and food industry. *Comprehensive Reviews in Food Science and Food Safety.* 1:33-44.

- Rozzi, N.L., Singh, R.K., Vierling, R.A. and Watkins, B.A. 2002. Supercritical fluid extraction of lycopene from tomato processing by products. *J. Agric. Food Chem.* 50:2638:34
- Rukmini, C., and Raghuram, T.C. 1991. Nutritional and biochemical aspects of the hypolipidemic action of rice bran oil : A review. *J Am. Col. Nutr.* 10: 593.
- Sah, A., Agrawal, B.K.D., and Shukla, L.S.. 1983. A new approach in developing and refining rice bran oil. *J. Am. Oil. Chem. Soc.* 60(2): 466.
- Saito, N., Ikushima, Y., Hatakeda, I. S., Asano, T., and Goto, T. 1993. Fractional extraction of rice bran oil and its esters with supercritical carbon dioxide. *International Chemical engineering.* 33(2): 307-14.
- Salunke, D.K., Chavan, K.J. K., Adsule, R.N., and Kadam, S.S., eds. 1992. Rice Ch.12 In *World Oilseeds Chemistry, Technology and Utilization.* Van Nostrand reinhold. New York. p435-48
- Santos, W. 1992. Rice bran oil demands improves but price too high to compete. *Chemical Marketing Reporter.* 242(6):20-21.
- Sarkar, S., and Bhattacharya, D.K. 1991. Nutrition of rice bran oil in relation to its purification. *J. Am. Oil. Chem. Soc.* 68(12): 956-60.
- Sato, M., Goto, M., Kodama, A. and Hirose, T. 1998. New fractionation process for citrus oil by pressure swing adsorption in supercritical carbon dioxide. *Chem. Eng. Sci.* 53(24): 4095-104.
- Saunders, R.M. 1986. Rice bran: composition and potential food uses. *Food Reviews International* .1(3): 465-95.
- Saunders, R.M. 1990. The properties of rice bran as a food stuff. *Cereal Foods World.* 35 (7) : 632–36.
- Sayre, R.N., Nayyar, D.K., and Saunders, R.M. 1985. Extraction and refining of edible oil from extrusion stabilized rice bran. *J. Am. Oil. Chem. Soc.* 62(6):1040-43.
- Sayre, R.N., Saunders, R.M., Enochian, R.V., Shultz, W.G., and Beagle, E.C. 1982. Review of rice bran stabilization systems with emphasis on extrusion cooking. *Cereal Foods World.* 27(7): 317-22.
- Schneider, G.M., Stahl, E., and Wilke, G., eds. 1980. Extraction with supercritical gases. Weinheim-Deerfield beach, Florida p189.
- Seetharamaiah, G.S., and Prabhakar, J.V. 1986. Oryzanol content of Indian rice bran oil and its extraction from soap stock. *J. Food Sci. Technol.* 23:270-73.

- Senorans, F. J., Rodriguez, A.R., Cavero, S., Cifuentes, A., Ibanez, E. and Reglero, G. 2001. Isolation of antioxidant compounds from orange juice by using counter current supercritical fluid extraction. *J. Agric. Food Chem.* 49:6039-6044.
- Shen, Z., Palmer, M.V., Ting, S.S.T., and Fair, C.R.J. 1996. Pilot scale extraction of rice bran oil with dense carbon dioxide. *J. Agric. Food Chem.* 44 (10): 3033-39.
- Shin, T.S., and Godber, J.S. 1993. Improved high performance liquid chromatography of vitamin E vitamers on normal phase columns. *J. Am. Oil. Chem. Soc.* 70: (12), 1289-91
- Shin, T.S., Godber, J.S., Martin, D.E. and Wells, J.H. 1997. Hydrolytic stability and changes in E vitamins and oryzanol of extruded rice bran during storage *J Food Sci.* 62(4): 704-08.
- Sivala, K., Bhole, N.G. and Mukherjee, R.K. and Bhole, N.G.. 1991. Effect of moisture on rice bran oil expression. *J. Agric. Eng. Res.* 50(2): 81-91.
- Sivala, K., Mukherjee, R.K. and Bhole, N.G. 1993. A preliminary study of rice bran oil expression in manually operated hydraulic press. *J. Food Eng.* 20(3): 215-22.
- Sistani, K.R., Savant, N.K., and Reddy, K.C. 1997. Effect of rice hull ash silicon on rice seedling growth. *J. Plant Nutr.* , 20 (1):195 –201.
- Sonntag, N.O.V. 1979. Composition and characteristics of individual Fats and oils. In Bailey's Industrial Oil and Fat Products. Vol:1 .D. Swern .ed.. Wiley, New York p122.
- Sovova, H. 1994. Rate of vegetable oil extraction with supercritical CO₂ – I: Modeling of extraction curve. *Chem. Eng. Sci.* 49 (3): 409-14.
- Sovova, H., Komers, R., Kucera, J. and Jez, J.1994. Supercritical carbon dioxide extraction of caraway essential oil. *Chem. Eng. Sci.* 49 (15): 2499-2505.
- Sovova, H., Kucera, J. and Jez, J. 1994. Rate of vegetable oil extraction with supercritical CO₂ – II: extraction of grape oil. *Chem. Eng. Sci.* 49 (3): 415-20.
- Stahl, E., Quirin, K.W., and Gerard, D. 1988. Dense gases for extraction and refining. Springer-Verlag, Berlin. p231.
- Sugano, M. and Tsuji, E.1997. Rice bran oil and cholesterol metabolism. *The Journal of Nutrition.* 127(3): 521S-4S.
- Sumanjit, P.N. 2001. Adsorption of dyes on rice husk ash. *Indian J. Chem., Sect. A: Inorg., Bioinorg., Phys., Theor. Anal. Chem.* 40A(4): 388-91.
- Takeshita, Y. 1993. Recent advances of cereal oil processing. Presented at 84th American Oil chemists Society Annual meeting, Naaheim, California.

- Takashi, Y., Akira, N., Kouchi, A., and Takeshita, Y. 1994. Supercritical fluid chromatographic determination of tocopherols on ODS- silica gel column. *J. of Chromatography A*. 679: 329-.
- Talwalkar, R.T., Garg, N.K., and Krishna Murti, C.R. 1965. Rice bran- a source material for pharmaceuticals. *J. Food Sci.and Technol.* 2:117-19.
- Tamura, I. T. and Matsumoto, T. 1973. Sterol composition of 19 vegetable oils. *J. Am. Oil. Chem. Soc.* 50:300-303
- Tan, B. and Brzuskiwicz, Z. 1989. Separation of tocopherol and tocotrienols isomers using normal and reverse phase liquid chromatography. *Anal. Biochem.* 180:368-73.
- Tan, C.S ., Liang, S.K. and Liou, D.C. 1988. Fluid-solid mass transfer in a supercritical fluid extractor. *The Chem. Eng. Journal* 38:17-22.
- Tao, J., Rao, R.M. and Liuzzo, J.A. 1994. Selected thermo physical properties of rice bran. *Applied Engineering in Agriculture* 10 (5): 709-711.
- Tarber, M.G., and Packer, L. Vitamin E beyond antioxidant function. *Am. J. Clin. Nutr.* 62:1501S-9S
- Taylor, S.L., and King, J.W. 2000. Optimization of the extraction and fractionation of corn bran oil using analytical supercritical fluid instrumentation. *J. of chromatographic science.* 38(3): 91-94.
- Taylor, S.L., King, J.W., and List, G.R.. 1993. Determination of oil content in oil seeds by analytical supercritical fluid extraction. *J. Am. Oil. Chem. Soc.* 70(4): 437-39
- Tehrani, J. 1993. Successful supercritical fluid extraction strategies. *American laboratory.* Feb.:40 HH-40 MM.
- Temeli, F., 1992. Extraction of triglycerides and phospholipids from canola with supercritical carbon dioxide and ethanol. *J. Food Sci.*57(2): 440-57.
- Tiwari, D.P., Singh D.K., and Saxena D.N. 1995. Hg (II) adsorption from aqueous solution using rice hull ash, *J. of Environmental Engineers*, 121(6): 479-81.
- Tsuda, T., Mizuno, K., Ohshima, K., Kawakishi, S., and Osawa, T. 1995. Supercritical carbon dioxide extraction of antioxidative components from tamarind seed coat. *J. Agric. Food. Chem.* 43:2803
- United Nations Industrial Development Organization (UNIDO). 1984. Rice husk ash cements: Their developments and applications.
- USA Rice .2003.USA rice federation at <http://www.usarice.com>.

USDA. 1981. Marketing Research Report No 1120: Stabilization of rice bran with extruder cookers and recovery of edible oil: a preliminary analysis of operational and financial feasibility. USDA research service

USDA.1983. Rice inspection handbook. Federal grain inspection series. 147 Washington D. C.

USDA .2004. Rice outlook by Nathan Child available at <http://usda.mannlib.cornell.edu/reports/erssor/field/rcs-bb/2004/RCS04kf.pdf> asp May 20, 2004

Vasco, E.M.C.R., Coelho, J.A.P. , Palavra, A.M.F., Marrone, C. and Reverchon, E. 2000. *Chem. Eng. Sci.* 55:2917-22.

Vedanayagam, H.S., Rao, D.V., Ali, Z., Madhavendra, S.S., and Kaimal, T.N.B. 1997. Rice hull ash for bleaching of vegetable oils. *J. Oil Technol. Assoc. India* 29(1):2-7.

Vellupillai, L., Mahin, D.B., Warrshaw, J.W. and Wailes, J.E. 1997. A study of the market for rice husk –to- energy systems and equipments. Louisiana State University Agricultural Center.

Walker, T. 1997. Supercritical carbon dioxide extraction of lipids from *phythium irregulare*. Ph.D. Dissertation. University of Tennessee, Knoxville.

Walker, T.H., Cochran, H.D., and Hulbert, G.J. 1999. Supercritical carbon dioxide extraction of lipids from *Pythium irregulare*. *J. Am. Oil. Chem. Soc.* 76(5): 595-602.

Wells, J.H.1993. Utilization of rice bran and oil in human diets. *Louisiana Agriculture.*36(3):5-8.

WHO. 1991. Health and Safety guide No:59: n-Hexane Health and Safety Guide, World Health Organization, Geneva.

Williams, D.F. 1981. Extraction with supercritical gases. *Chem. Eng. Sci.* 36(1):1769-1788.

Williams, J. R., and Clifford, A. A. (ed.) 2000. Supercritical fluid methods and protocols. Humana press, Totowa, New Jersey

Wim, De. G. and Marc, K. ed. Edible Oil Processing. Wolf H, CRC Press. 2000.

Wong, V., Wyllie, S.G., Cornwell, C.P. and Tronson, D. 2001. Supercritical Fluid Extraction of Monoterpenes from the Leaves of Tea tree. *Molecules* 6:92-103

Xu, Z. 1998. Purification and antioxidant properties of rice bran γ -oryzanol components. Louisiana State University. PhD dissertation.

Xu, Z., and Godber, J. S. 1999. Purification and identification of components of γ -oryzanol in rice bran oil. *J. Agric. Food Chem.* 47 (7):2724-2728.

Xu, Z., and Godber, J. S. 2000. Comparison of supercritical fluid and solvent extraction methods in extracting γ -oryzanol from rice bran. *J. Am. Oil. Chem. Soc.* 77 (5):

Xu, Z., Hua, N., and Godber, J. S. 2001. Antioxidant activity of tocopherols, tocotrienols and γ -oryzanol components from rice bran against cholesterol oxidation accelerated by 2,2- Azobis (2-methylpropionamidine) dihydrochloride. *J. Agric. Food Chem.* 49:2077-2081.

Yokochi, K. 1977. Rice bran processing for the production of rice bran oil and characteristics and uses of the oil and deoiled meal. In *Proceedings of rice by-products utilization international conference* Vol. III. Rice bran utilization: oil. Ed. Barber and E. Tortosa pp. 1-38. Inst. Agric. Chem. and Food Tech., Valencia, Spain

Zhao, W., Shishikura, A., Fujimoto, K., Arai, K., and Saito, S. 1987. Fractional extraction of rice bran oil with super critical carbon dioxide. *Agric. Biol. Chem.* 51 (7). 1773-77.

Appendix

Materials and Methods

A.1 Experimental Raw Materials

The stabilized rice bran was procured from Producers Rice Mill (Stuttgart, AR) in sufficiently large quantities from a single lot of bran. Care was taken to obtain bran from a single variety to minimize the experimental variation due to differences in rice variety. The bran was of long grain rice variety “Wells”, which is increasingly popular in major rice growing areas of Arkansas due to its reportedly high returns. The bran was separated in a 14 mesh (1.18 mm) sieve and was stored at -16°C until use. The moisture content of bran was determined using the oven drying method (105°C for 24 hour) and averaging 10 observations. The rice bran used for the experiments is shown in Figure A.1

Agrilectric Power (Lake Charles, LA) donated industrial rice hull ash for experimental use. The Agrilectric Corporation has built a 13 MW plant that generates electricity from rice hulls. The rice hull ash used in this experiment was a by-product from this plant. The detailed composition of rice hull ash as per the manufacturer’s analysis are given in Table 5.1. Rice hull ash used for the experiments is shown in Figure-A.1-2. The ash was stored at room temperature. The properties of rice bran and rice hull ash such as bulk density, particle density, porosity, particle size and size distribution and surface area were measured. To measure bulk density of rice bran (ash), the USDA (1983) procedure was used. The particle density was determined by taking the ratio of bran (ash) weight to the volume of solid particles. The volume of solid particles was obtained from porosity measurements. The porosity measurement procedure outlined by Farral (1979) was used and consisted of adding water to the bran in a container of known volume. The volume of water was recorded after the complete saturation of bran. The porosity of bran, expressed as percentage, was obtained by calculating the ratio of



Figure A.1. Stabilized rice bran used for the experiments

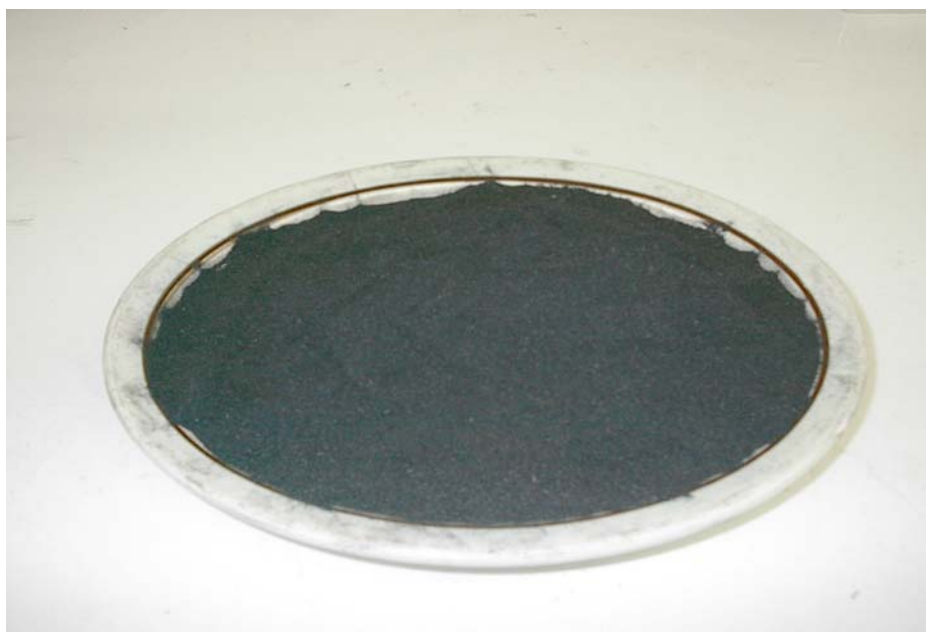

Figure A.2 Rice hull ash used as adsorbent

the added volume of water to the total volume of the container (Tao et al., 1994) Particle size and size distribution of the bran and ash were determined by scanning electron microscopy (SEM) at the LSU Center for Advanced Microstructure and Devices (CAMD) lab of LSU. Similarly the surface area of the particles were obtained using facilities at the CAMD lab.

A.2 Description of Pilot Scale Extraction Equipment

The supercritical fluid extraction equipment used in the present experiment was designed and fabricated by Thar Technologies (Pittsburgh, PA) with an integrated co-solvent pump. The extractor volume was 3 liters. Specification for the system were a maximum flow rate, maximum pressure and maximum temperature of 200g/min, 68 MPa and 150 °C respectively. The co-solvent pump's capacity was 40 MPa with a maximum solvent flow rate of 10 ml/min. The back pressure regulator was capable of handling flow rates up to 350g/min. The collection system consisted of three one-liter capacity cyclones with heated jackets. Solvent compatible with the system included carbon dioxide, methanol, ethanol, acetonitrile, isopropyl alcohol, chloroform and methylene chloride. The flow diagram of the system is given in Figure 3.3.2 whereas a picture of system is shown in Figure 3.3.1. The system was controlled and operated with a personal computer with feedback from pressure, temperature and flow sensors. The system was also computer controlled and current operating conditions of the system displayed.

A.3 Supercritical Fluid Extraction Procedures and Details of Experiments

Before starting each extraction, the extraction vessel and cyclones were cleaned thoroughly using paper towel. Rice bran and glass beads (3 mm size) were weighed and thoroughly mixed in the desired proportion (750g bran and 1100 g beads) with rice bran to ensure uniform flow of carbon dioxide through the bran and prevent possible channeling. The bran-glass bead mixture was then poured into the vessel using a plastic funnel. Rice hull ash (200 g) was placed on top of the bran in case of with ash experiments. Glass wool was placed on top of the vessel and it was

closed with the hand-tighten lid. CO₂ tubing to the backpressure regulator was then connected and valves were kept in the appropriate position to maintain required flow of CO₂ as per the standard operating procedures supplied with the SFE system. The operation procedures supplied with the equipment were followed with proper settings for temperature, pressure and flow rate of CO₂, depending on the experimental conditions under investigation (Table A.2.1). Since modifier was not used in the system, the valve for that pump was kept closed all times. The collection cyclone temperature was kept at 35 °C for all experimental runs. The valves carrying flow to the cyclone were regulated, depending on the collection time of the sample. During the extraction, samples of extracted rice bran were collected from the cyclone by use of valve. After collecting a sample the particular cyclone was cleaned using fresh paper towel until no subsequent oil was sticking on paper from wall or the bottom of the cyclone.

Extraction experiments were conducted in duplicate. For each extraction run samples were collected at six different times (30, 60, 90, 120, 180, 240 min from start of extraction). In each experiment, the rice bran weight (750 g) and glass bead weight (1100 g) were kept constant. For experiments with rice hull ash, 200 g of ash was placed on top of the bran. Samples were collected at different times in pre-weighed sample vials and then weighed. The sample of rice bran oil extract collected at the end of SFE extraction in a vial were stored in the refrigerator and later analyzed with an high pressure liquid chromatography (HPLC) for determination of oryzanol, tocopherols and tocotrienols components in the oil

A.4 Solvent Extraction of Rice Bran Oil

For comparison, rice bran oil samples were extracted using the conventional Soxhlet extraction process following standard AOAC procedures (No-Aa-4-38). Twenty grams of rice bran were placed in an extraction thimble and was extracted using petroleum ether solvent at °C for 6 hr. The solvent containing oil was then evaporated by boiling in a conventional nitrogen

Table A.2.1 Details of experimental treatments

Parameter	Experimental Values
Pressure (MPa)	27.6, 41.4 and 55.2
Flow (g/min)	25, 45 and 65
Temperature (°C)	40 and 60
Quantity of RHA	0 and 200 g

water bath. After the complete removal of petroleum ether, the oil was weighed. The oil sample extracted using the Soxhlet method was analyzed with HPLC to determine antioxidants.

A.5 Analysis of Rice Bran Oil

Aliquots of extract (1 ml) from SFE for each extraction run and the collection time were taken and was thoroughly mixed with 5 ml of hexane using magnetic stirrer for analysis by HPLC. A sample (1000 μ l) was placed in the injection vials for HPLC analysis. The HPLC system consisted of WatersTM (Milford, Ma) 510 HPLC pump, a 717plus WatersTM injector, a 470 scanning fluorescence detector (for tocopherols and tocotrienols) with excitation at 290 nm and emission at 330 nm. A SupelcosilTM (Supelco, Bellefonte, PA) LC-Si, 5 μ m, 25cm X4.6 mm i.d. column was used. The mobile phase consisted of hexane: ethyl acetate: acetic acid (98.4 :0.8:0.8) at a flow rate of 1.9 ml/min. For analysis of oryzanol, the same system and sample was with WatersTM 486 absorbance detector at 330 nm used. The Millennium³² (Milford, MA) software was used to monitor and record signals from the detectors. Chromatogram obtained (Figure 3.3.3) were compared with those of external standards of oryzanols and tocopherols to obtain the concentration. Concentrations of Oryzanol, tocopherol and tocotrienol were obtained by summing all individual components. After each of the supercritical fluid extraction experiment the remaining rice bran was collected to determine residual oil using soxhlet extraction for 6 hr with petroleum ether and sample size of 20 g. The residual oil percentage was calculated on the basis of bran weight.

A.6 Adsorption Study With Rice Hull Ash

For better understanding and characterization of the adsorption process of rice bran oil on rice hull ash, a separate batch adsorption study was conducted. Ash in varying quantity (5, 10, 20 g) were mixed with 100 ml of rice bran : hexane miscella (20:80 v/v) and agitated in a stirrer at 200 rpm. The oil samples were kept in the agitator for different durations (30, 60, 90, 120 and

180 min) at different temperatures (20, 30 and 40 °C) to generate adsorption isotherm data. After agitation, the mixture was filtered using Whatman filter paper (1004,150) and residual quantity of unadsorbed oil was measured. Oil adsorbed on the hull ash for particular sample was calculated from the difference in initial and final volume of the miscella. The sample from unadsorbed oil was analyzed using HPLC to know antioxidant components.

Vita

The author was born in Gujarat, India, in August, 1966. He graduated from Gujarat Agricultural University with a bachelor's degree in agricultural engineering in November 1988. He joined Gujarat Agricultural University (GAU) in June 1989. At GAU, He served as Technical Assistant at the College of Agricultural Engineering and Technology, Junagadh, and Senior Research Assistant at Agricultural Product Process Engineering, Anand. He served on several teaching, research and extension projects in the area of agricultural engineering and food process engineering during services at GAU. He also completed his master's degree in agricultural engineering with specialization in agricultural process and food engineering at GAU in September 1997.

In January 2001, he joined Louisiana State University, Baton Rouge, for his doctoral studies in engineering science at the department of Biological and Agricultural Engineering. He also worked as Graduate Research Assistant at Louisiana State University in Food and Bioprocess Engineering Laboratory. The author is affiliated with several professional organizations and has been nominated for several honor societies.

The author married to Ms. Varsha Patel in 1989 and his son Nisarg Patel was born in 1992.

The author is currently a candidate for the degree of Doctor of Philosophy in engineering science at Louisiana State University, Baton Rouge.