

CTP: PHOSPHOETHANOLAMINE CYTIDYLYLTRANSFERASE AND DAG: CDP-
ETHANOLAMINE ETHANOLAMINEPHOPHOSTRANSFERASE IN THE CDP-
ETHANOLAMINE PATHWAY OF *CHLAMYDOMONAS REINHARDTII*

A Dissertation
Submitted to the Graduate Faculty of the
Louisiana State University and
Agricultural and Mechanical College
in partial fulfillment of the
requirements for the degree of
Doctor of Philosophy

In

The Department of Biological Sciences

by

Wenyu Yang
B.Sc., Heilongjiang August-1 Agricultural University, 1983
M.Sc., University of Guelph, 1989
August 2004

ACKNOWLEDGEMENTS

I would like to give my sincere gratitude to Dr. Thomas S. Moore, my major advisor, for his kind effort and support during my dissertation research and course study. I want to thank him for offering me this opportunity to study as a graduate student in his laboratory and for providing extraordinary experimental conditions to complete this work. I would like to thank Dr. James V. Moroney for his generous support for some of the experiments conducted in his laboratory, and his valuable suggestions to the dissertation research. I am also grateful to the other members of my committee, Dr. David Longstreth and Dr. Sue Bartlett, for their considerate help, comments and suggestions during my graduate study and dissertation research. I would like to acknowledge the help from all of my colleagues in both laboratories in the experimental work.

I would like to thank my mother for her support for my graduate study. I want also to thank my wife, Wei Zhang, and my son, Shen Yang, for their support, patience and understanding during my graduate study.

TABLE OF CONTENTS

ACKNOWLEDGEMENTS	ii
LIST OF TABLES	v
LIST OF FIGURES	vi
LIST OF ABBREVIATIONS	viii
ABSTRACT	ix
 CHAPTER 1	
LITERATURE REVIEW	1
Membrane Lipids of Photosynthetic Organisms	1
a. Studies of Membrane Lipids in Plants	1
b. Phospholipids of Plants	2
c. <i>C. reinhardtii</i> as a Model Organism for Study of PE Biosynthesis	4
CDP-ethanolamine Pathway	5
a. Ethanolamine Kinase	7
b. CTP: Phosphoethanolamine Cytidylyltransferase	14
c. DAG: CDP-ethanolamine Ethanolaminophosphotransferase	23
 CHAPTER 2	
INVESTIGATIONS ON CTP: PHOSPHOETHANOLAMINE CYTIDYLYLTRANSFERASE	33
Materials and Methods	33
a. cDNA Library Preparation	33
b. cDNA Cloning and DNA Sequencing	33
c. Sequence Analysis	35
d. Expression in <i>Escherichia coli</i>	35
e. Southern and Northern Blot Analyses	36
f. Cell Fractionation by Differential Centrifugation	37
g. Enzyme Activity during Cell Cycle	38
h. Enzyme Activity at Different pH, Cations and Substrate Concentrations	38
Results	40
a. Cloning of <i>ECT</i> cDNA	40
b. Sequence Analysis	41
c. Location of the ECT in the Cells	49
d. Expression of ECT in <i>E. coli</i> Cells and ECT Activity Assay	53
e. Genomic Copy Number and Expression in <i>C. reinhardtii</i>	53
f. Enzyme Activity during the Cell Cycle	53
g. Enzyme Activity at Varying pH, Cations and Substrate Concentrations	56
Discussion	61

CHAPTER 3	
STUDY OF ETHANOLAMINEPHOSPHOTRANSFERASE	71
Materials and Methods.....	71
a. cDNA Cloning and Sequencing	71
b. Sequence Analysis	72
c. Southern Blot of Genomic DNA	73
d. Expression of <i>C. reinhardtii</i> <i>EPT</i> cDNA in <i>S. cerevisiae</i>	73
e. Inhibition Assays of EPT by CDP-aminoalcohols and CMP	75
Results	77
a. Sequence Analysis of the <i>EPT</i> Gene.....	77
b. Complementation of a Yeast Mutant with the <i>EPT</i> cDNA	88
c. Inhibition of EPT by CDP-aminoalcohols and CMP	91
Discussion.....	95
 CHAPTER 4	
CONCLUSIONS	100
 REFERENCES	108
 APPENDIX: RELATED EST CLONES AND GENES OF ECT AND EPT IN DATABASE	125
 VITA	129

LIST OF TABLES

Table 2.1	Identity and similarity between ECT proteins in various organisms	48
Table 2.2	Percentage of the total activity and specific activity of marker and ECT enzymes in various cellular fractions of <i>C. reinhardtii</i>	52
Table 3.1	Identity and similarity between aminoalcoholphosphotransferases in various organisms	80
Table A1	EST clones obtained from searching the <i>C. reinhardtii</i> EST database using the ECT protein sequences of <i>H. sapiens</i> and <i>R. norvegicus</i>	125
Table A2	The accession numbers of nucleotide and protein sequences of EPT genes of various organisms in GenBank	126
Table A3	Summary of the ECT gene structure in <i>C. reinhardtii</i> genome	127
Table A4	Summary of the EPT gene structure in <i>C. reinhardtii</i> genome	128

LIST OF FIGURES

Figure 1.1	The interrelationship between the biosynthetic pathways of PC, PE and PS in eukaryotic cells	6
Figure 1.2	CDP-ethanolmaine pathway of PE biosynthesis	8
Figure 2.1	Nucleotide and deduced amino acid sequences of <i>C. reinhardtii</i> ECT cDNA	43
Figure 2.2	Alignment of amino acid sequences of <i>C. reinhardtii</i> ECT and other ECTs in <i>H. sapiens</i> , <i>R. norvegicus</i> and <i>S. cerevisiae</i>	45
Figure 2.3	Hydropathy and α -helix amphiphilicity profiles of the predicted protein sequence of <i>C. reinhardtii</i> ECT	46
Figure 2.4	Sequence alignment of the N-terminal and C-terminal halves of the internal repetitive sequence of ECTs in different organisms	50
Figure 2.5	Phylogram of ECT proteins in different organisms	51
Figure 2.6	Expression of MAL-ECT fusion gene in <i>E.coli</i>	54
Figure 2.7	ECT activity of the MAL-ECT fusion protein expressed in <i>E.coli</i> under different conditions	55
Figure 2.8	Nucleic acid analysis of the <i>C. reinhardtii</i> ECT gene	57
Figure 2.9	Activity of ECT during the cell cycle	58
Figure 2.10	Effect of pH on the ECT activity	59
Figure 2.11	Effect of different divalent cations on the ECT activity	60
Figure 2.12	Lineweaver-Burk plot of fixed substrate concentration at various concentration of other substrates	62
Figure 3.1	Nucleotide and deduced amino acid sequences of <i>C. reinhardtii</i> EPT cDNA	78
Figure 3.2	Sequence alignment of aminoalcoholphosphotransferases in different organisms	82

Figure 3.3	Phylogram of aminoalcoholphosphotransferases in different organisms	86
Figure 3.4	Hydropathy profile of the predicted <i>C. reinhardtii</i> EPT protein and yeast EPT1 and CPT1	87
Figure 3.5	Southern blot analysis of <i>EPT</i> gene in genome of <i>C. reinhardtii</i> strain CC-406 cw15 (<i>mt⁻</i>) and the <i>EPT</i> gene structure	90
Figure 3.6	Colony autoradiographic assays for CPT activity in yeast	93
Figure 3.7	Effect of CDP-choline and CDP-ethanolamine on the incorporation of [¹⁴ C]-CDP-choline into PC by <i>C. reinhardtii</i> EPT and yeast EPT/CPT enzymes	94
Figure 3.8	Effect of CMP on the incorporation of [¹⁴ C]-CDP-choline into PC by <i>C. reinhardtii</i> EPT and yeast EPT/CPT enzymes	96
Figure 4.1	Genomic locations of <i>ECT</i> and <i>EPT</i> genes in <i>C. reinhardtii</i>	103
Figure 4.2	A model for a translocation mechanism of ECT within <i>C. reinhardtii</i> cells	106

LIST OF ABBREVIATIONS

AAPT	aminoalcoholphosphotransferase
CDP	cytidine diphosphate
CTP	cytidine triphosphate
CCT	CTP: phosphocholine cytidyltransferase
CDP-Ethn	cytidine diphosphate-ethanolamine
ECT	CTP: phosphoethanolamine cytidyltransferase
EPT	diacylglycerol: CDP-ethanolamine ethanolaminephosphotransferase
ER	endoplasmic reticulum
EST	expressed sequence tag
Ethn	ethanolamine
IPTG	isopropylthiogalactopyranoside
PC	phosphatidylcholine
PE	phosphatidylethanolamine
PG	phosphatidylglycerol
PI	phosphatidylinositol
PS	phosphatidylserine
P-Ethn	Phosphoethanolamine
ORF	open reading frame

ABSTRACT

Chlamydomonas reinhardtii Dangeard does not have two major phospholipids, PS and PC. This fact renders *C. reinhardtii* a desirable system for investigations of the PE biosynthetic pathway and its regulation independent of PC and PS biosynthesis. The cDNA coding for ECT protein in *C. reinhardtii* was cloned from a cDNA library. The *ECT* cDNA encodes a protein of 443 amino acid residues. The ECT protein in *C. reinhardtii* has a repetitive internal sequence in its N- and C-terminal halves. Each repeat half of the protein has a HXGH motif, a site considered to be in the catalytic domain. The protein has a RTXGVSTT signature sequence typical of the cytidylyltransferase family. The first 70 amino acid residues appear to be a subcellular targeting signal to mitochondria. The translated product of cloned cDNA was expressed as a fusion protein with maltose-binding protein in *E. coli*, and was shown to have ECT activity. Northern blot analysis showed mRNA abundance is increased by reflagellation. The enzyme requires Mg^{2+} and pH 7.5 for maximum activity *in vitro*, and it appears to have a sequential reaction mechanism. The activity of the enzyme *in vivo* in *C. reinhardtii* cells changes during the cell cycle while the mRNA level does not change. A cDNA coding for EPT protein was obtained from a *C. reinhardtii* cDNA library. The *EPT* cDNA encodes a protein of 383 amino acid residues. The EPT protein has a signature sequence and a conserved region in the CDP-alcohol phosphatidyltransferase family. Very similar membrane topology was found between the *C. reinhardtii* EPT and the aminoalcoholphosphotransferases from mammals, yeast and plants. A yeast mutant deficient in both cholinephosphotransferase and ethanolaminephosphotransferase was

complemented by the *C. reinhardtii* *EPT* gene coding for EPT. Enzymatic assays of *C. reinhardtii* EPT from the complemented yeast microsomes demonstrated that the *C. reinhardtii* EPT synthesized PC in the transformed yeast. EPT activity from the transformed yeast or *C. reinhardtii* cells was inhibited nearly identically by unlabeled CDP-choline, CDP-ethanolamine and CMP. This provides evidence that *C. reinhardtii* EPT is capable of catalyzing the final step of phosphatidylcholine biosynthesis, as well as that of phosphatidylethanolamine.

CHAPTER 1

LITERATURE REVIEW

Membrane Lipids of Photosynthetic Organisms

a. Studies of Membrane Lipids in Plants

In addition to a structural role in cellular membranes, membrane lipids play important roles in plant metabolic processes such as photosynthesis, morphology of organelles and tolerance to environmental stresses (Gibson et al., 1994). Membrane lipids also are precursors of signal molecules such as phosphoinositides and jasmonic acid (Trewavas and Gilroy, 1991). With a general objective to examine the relationships between lipid composition and biological functions, most studies on membrane lipids have been concentrated on the composition of storage oils and the functions of glycerolipids in stress tolerance, although other aspects of plant physiology and development have been investigated. Since plant membranes are mixtures of many lipid species, the lipid composition varies considerably in various membranes and plant species. This variability makes it difficult to establish a correlation between a specific difference in lipid composition and a particular phenotype. Studies of plant lipid biochemistry with biochemical approaches have been limited since most of the proteins in lipid metabolism are membrane-associated and difficult to purify in an active form (Slabas and Fawcett, 1992; Moore, 1993). In contrast, genetic approaches used to study membrane lipid function have proven very useful. The advent of plant genetic engineering in combination with molecular cloning of the genes encoding enzymes involved in lipid biosynthesis have provided new approaches to study membrane lipid

metabolism and new insights into the improvement of economical traits of certain plant species (Murata and Sommerville, 1993).

b. Phospholipids of Plants

The major phospholipids of photosynthetic organisms are phosphatidylcholine (PC), phosphatidylethanolamine (PE), phosphatidylserine (PS), phosphatidylglycerol (PG) and phosphatidylinositol (PI). Most of these phospholipids are found in all the membranes of plant cells but their relative amounts may vary among various plant species (Harwood, 1980; Moore, 1982). The distribution of phospholipid species also varies in the membranes of organelles. For example, PE is reduced in the chloroplast envelopes when compared with PC, and PS is usually absent from chloroplast membranes. Lipid asymmetry in the thylakoid membranes has been studied extensively (Williams, 1994). PC and PG are more enriched in the stromal leaflet of the thylakoids than in the luminal leaflet. The distribution of phospholipids in organelle membranes from castor bean endosperm demonstrates that the glyoxysomal and mitochondrial membranes are distinctly asymmetric with respect to phospholipids (Cheesbrough and Moore, 1980).

The lipid composition of lower plants has been studied less extensively since they are considered economically less significant in comparison with higher plants, although the study of their lipids may have general significance for understanding the evolution of the whole plant kingdom. The bryophytes, which mainly include mosses and liverworts, have been studied recently with respect to lipid composition. Some unusual phospholipids, fatty acids and polar lipids were found in their membranes (Dembitsky, 1993). The content of phospholipids in various moss and liverwort species varies

considerably, although PC and PG are the main phospholipid species in the bryophytes. A polar lipid, 1(3), 2-diacylglycerol-*O*-4'-(*N, N, N*-trimethyl) homoserine (DGTS), was found in some species of bryophytes. DGTS is a betaine lipid and is detected in lower plants, particularly in cryptogamic green plants including pteridophytes, bryophytes and chlorophytes (Sato and Furuya, 1985). It has been suggested that DGTS plays a role similar to that of PC, based on its zwitterionic structure and its concentrations which are generally inversely proportional to PC in those species that possess both PC and DGTS (Brown and Elovson, 1974; Sato, 1988; Sato and Kato, 1988; Eichenberger, 1993; Moore et al., 2001).

The membrane lipids of *Chlamydomonas reinhardtii* Dangeard have also been studied with respect to their composition and biosynthesis (Eichenberger, 1976; Janero and Barnett, 1981a, 1981b, 1981c, 1982a, 1982b; Giroud et al., 1988). The major lipids in the membranes of *C. reinhardtii* are monogalactosyldiacylglycerol (MGDG), digalactosyldiacylglycerol (DGDG), sulfoquinovosyldiacylglycerol (SQDG), DGTS, PG, PE and PI. No PC or PS has been found in the membranes of *C. reinhardtii* (Giroud et al., 1988). MGDG, DGDG, SQDG, PG and PI were found to be of plastidic origin (prokaryotic), while DGTS and PE were from cytoplasmic organelles (eukaryotic). Prokaryotic lipids mainly contained 18:2, 18:3, 16:4 and 16:3, while eukaryotic lipids were rich in 18:1, 18:2, 18:3 and 18:4 fatty acids. During the biosynthesis of each lipid class, all the lipids appear to act individually as substrates for the lipid-linked desaturation of fatty acids since each lipid class has an individual pattern of molecular species. The 18:3 and 18:4 fatty acids were found to be synthesized in the cytoplasm using DGTS and PE as substrates (Giroud et al., 1988).

c. *C. reinhardtii* as a Model Organism for Study of PE Biosynthesis

C. reinhardtii has been used as a model organism in molecular and genetic studies of flagellar structure and function, genetics of basal bodies, photosynthesis, chloroplast biogenesis, light perception, cell-cell recognition, and cell cycle control (Rochaix, 1995; Harris, 2001). *C. reinhardtii* facilitates such studies since it has a number of advantages. It is unicellular and eukaryotic. It can grow nonphotosynthetically with acetate as its sole carbon source as well as by photosynthesis. It has a very short life cycle, and both asexual and sexual reproduction. Its genetics is well defined with all three genomes having genetic markers. All three genomes (nuclear, chloroplast and mitochondrial) can be transformed efficiently and conveniently (Boynton et al., 1988; Kindle, 1990; Dunahay, 1993; Shimogawara et al., 1998); and mutant stocks and DNA clones are available (http://www.yale.edu/rosenbaum/chlamy_resources.html); EST clones and genomic sequences have been released recently (http://www.biology.duke.edu/chlamy_genome/index.html, <http://genome.jgi-psf.org/chlre1/chlre1.home.html>). Like yeast, *C. reinhardtii* has identifiable genetically fixed mating types (mt^+ and mt^-) and can be easily crossed. The nuclear genome size is estimated as approximately 1×10^8 base pairs (Harris, 1989; Rochaix, 1995). The nuclear DNA has a pronounced codon bias which favors codons with C or G in the third position and reflects the high GC content of the genome, about 62% overall in denaturation studies and sequence analysis. Adenosine-rich elements may be found in TATA-resembling boxes upstream of the nuclear genes with adjacent GC-rich stretch. A polyadenylation motif TGTAAT may be present in some cases at the 3' end 10~15 nucleotides upstream of the polyadenylation site (Rochaix, 1995). One general feature of *C. reinhardtii* genes is that many small

introns are often present at high frequency. On average, four introns are located within each kilobase of coding sequence and the average number of introns in each gene is about six with the average intron size of 219 base pairs. Within an average gene, the total sequence contained in introns is nearly equal to the total coding sequence (Silflow, 1998).

Chlamydomonas reinhardtii has a unique lipid composition when compared to higher plants. Three major phospholipids, PE, PG and PI, are present in its membranes. Two other major phospholipids, PS and PC, are missing. These facts make *C. reinhardtii* a desirable system for investigations of PE biosynthetic pathway and regulation independent of PC and PS biosynthesis, which often are interrelated with that of PE (Figure 1.1). In particular, the biosynthesis of PE through PS decarboxylation cannot occur, since PS is not present; the base exchange reaction of free ethanolamine with a choline headgroup also cannot take place, since PC does not occur.

CDP-ethanolamine Pathway

Phosphatidylethanolamine (PE) is a major phospholipid component in the membranes of eukaryotic cells. In addition, PE can be acylated to form *N*-acylphosphatidylethanolamine which plays a role in protection of membranes during tissue damage and in membrane stabilization during seed germination (Schmid et al., 1990; Chapman and Moore, 1993; Chapman, 2000). PE is also a precursor of the *N*-acylethanolamine which functions as a neurotransmitter in the brain (Devane et al., 1992). PE was also found as a precursor of the ethanolamine residue linking a glycosylphosphatidylinositol anchor to protein in yeast (Menon and Stevens, 1992, Imhof et al., 2000). PE plays a role in cytokinesis in that the redistribution of PE on the plasma membrane surface may regulate actin cytoskeleton organization and may mediate a

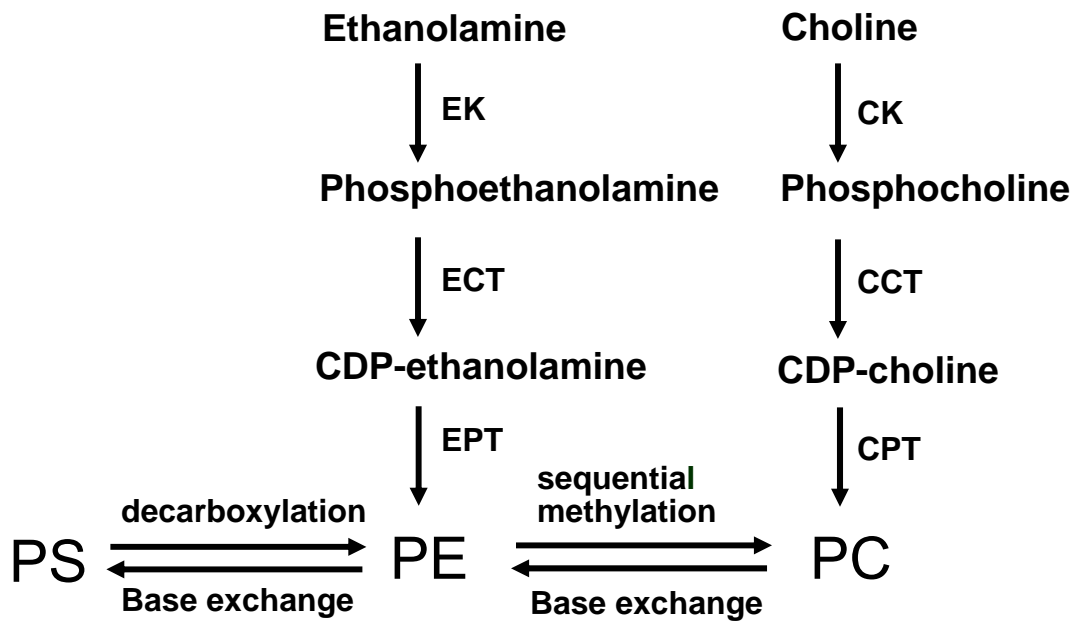

Figure 1.1 The interrelationship between the biosynthetic pathways of PC, PE and PS in eukaryotic cells. EK, ethanolamine kinase; CK, choline kinase; ECT, CTP: phosphoethanolamine cytidylyltransferase; CCT, CTP: phosphocholine cytidylyltransferase; EPT, ethanolaminephosphotransferase; CPT, cholinephosphotransferase.

coordinate movement between plasma membrane and actin cytoskeleton to achieve successful cell division (Umeda and Emoto, 1999). Moreover, PE may regulate lipid homeostasis via the sterol regulatory element-binding protein in *Drosophila melanogaster* (Dobrosotskaya et al., 2002).

The CDP-ethanolamine pathway is catalyzed by three enzymes: ethanolamine kinase (EK) [EC 2.7.1.82], CTP: phosphoethanolamine cytidyltransferase (ECT) [EC 2.7.7.14] and diacylglycerol: CDP-ethanolamine ethanolaminephosphotransferase (EPT) [EC 2.7.8.1] (Figure 1.2).

EK catalyzes the phosphorylation of ethanolamine by ATP in the presence of Mg^{2+} , producing phosphoethanolamine and ADP. ECT catalyzes the synthesis of CDP-ethanolamine from CTP and phosphoethanolamine with pyrophosphate as the second product. EPT catalyzes the final reaction of the CDP-ethanolamine pathway for the *de novo* synthesis of PE with CMP as the second product. This pathway was first elucidated by Kennedy and Weiss in 1956 in their study of PE biosynthesis using rat liver as the enzyme source, and is referred to as the Kennedy pathway or CDP-ethanolamine pathway (Kennedy and Weiss, 1956).

a. Ethanolamine Kinase

Occurrence and Localization

The occurrence of ethanolamine kinase was not clearly established until the discovery of the CDP-ethanolamine pathway by Kennedy and Weiss in 1956, although the similar enzyme choline kinase (CK) was discovered earlier in yeast as a cytoplasmic enzyme that was capable of phosphorylating both choline and ethanolamine (Wittenberg and Kornberg, 1953; Kennedy and Weiss, 1956). Since the earliest characterization and

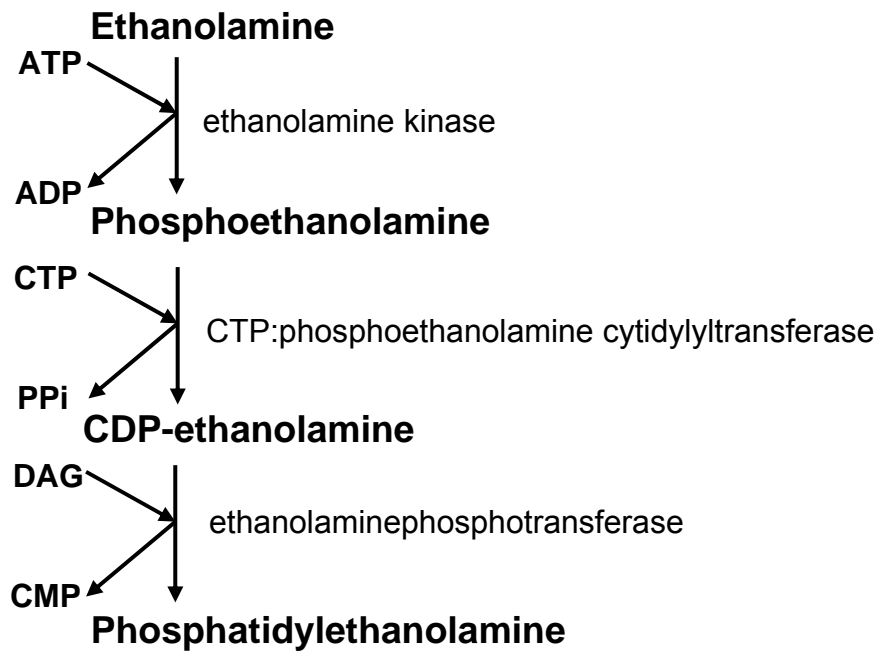

Figure 1.2 CDP-ethanolamine pathway of PE biosynthesis. ATP, adenosine triphosphate; ADP, adenosine diphosphate; CTP, cytidine triphosphate; PPI, pyrophosphate; DAG, diacylglycerol; CMP, cytidine monophosphate.

purification of choline kinase, which were performed using rat tissues, demonstrated that the enzyme can phosphorylate both choline and ethanolamine, it is believed that both choline kinase and ethanolamine kinase are the same protein in mammals. Sometimes the enzyme is collectively called choline/ethanolamine kinase (CK/EK). Therefore, it is not possible to review ethanolamine kinase without also reviewing choline kinase.

It is now accepted that ethanolamine kinase exists in all eukaryotic cells. In most cases reported previously, the ethanolamine kinase activity could be recovered in the supernatant of the tissue or cell homogenates. This indicates that the enzyme is primarily localized in the cytoplasm.

Substrate Specificity and Regulation

It has been a controversy for a long time whether the same enzyme catalyzes the phosphorylation of both choline and ethanolamine. In yeast, it has been found that the choline kinase and ethanolamine kinase activities are associated with the same protein (Hosaka et al., 1989; Kim et al., 1999). In higher plants, the two enzymes appear to be separate with distinct substrate specificities and activities (Macher and Mudd, 1976; Wharfe and Harwood, 1979; Monks et al., 1996). In mammals, in most cases both reactions of choline and ethanolamine phosphorylation may be catalyzed by the same enzyme (Porter and Kent, 1990, 1992; Ishidate and Nakaszawa, 1992; Uchida and Yamashita, 1992a, 1992b).

Most of our knowledge about CK and EK comes from studies that were conducted using rat kidney, liver and brain. The majority of these studies produced the consistent conclusion that a major part of CK and EK activities are catalyzed by the same enzyme in mammalian tissues. However, this does not rule out the possibility for

existence of an ethanolamine-specific kinase that is encoded by a different gene. A few early reports suggested the existence of a separate EK in mammalian species (Weinhold and Rethy, 1974; Brothy et al., 1977; Uchida, 1997), and much higher EK activity than CK activity was found in a partially purified preparation from human liver (Draus et al., 1990). Thus, whether CK and EK have the same identity is directly correlated with the possible independent regulation of CDP-choline and CDP-ethanolamine pathways in PC and PE biosynthesis in mammals.

Based on the theoretical principles of metabolic regulation in the Kennedy pathway for the synthesis of phosphatidylcholine and phosphatidylethanolamine in mammals, it was proposed that the first two reactions catalyzed by ethanolamine kinase and CTP: phosphoethanolamine cytidyltransferase are rate-limiting steps (Infante, 1977). However, limited evidence was reported to support the rate-limiting role of EK in the CDP-ethanolamine pathway in the biosynthesis of phosphatidylethanolamine (McMaster et al., 1992). In contrast, there is considerable evidence that indicates CK can be rate-limiting for PC biosynthesis in a number of situations in which changes in CK activity result in corresponding changes in the rate of PC synthesis (Kent, 1990).

CK/EK has been found inducible in a number of situations (Ishidate, 1989). This may suggest that the enzyme plays a role in the regulation of the CDP-choline or CDP-ethanolamine pathway in PC and PE biosynthesis. In addition, it has been reported that CK/EK can exist in several isoforms in various mammalian tissues and some of these isoforms have been purified (Ishidate et al., 1985; Ishidate, 1997; Aoyama et al., 2002). The physiological significance of the existence of more than one form of the enzyme is not clear. It is known that choline/ethanolamine kinase may exist in at least three

isoforms (alpha1, alpha2 and beta) in mammalian cells. In a recent study, the expression and distribution of the isoforms in mouse tissues using isoform-specific cDNA probes and polyclonal antibodies raised against each N-terminal peptide sequence were examined (Aoyama et al., 2002). Northern- and Western-blot analyses indicated that either the alpha (alpha1 and alpha2) or the beta isoform appeared to be the ubiquitously expressed enzyme. The immunotitration analysis indicated that a considerable part of the active form of the enzyme consists of alpha/beta hetero-oligomers, with relatively small parts of activity expressed by alpha/alpha and beta/beta homo-oligomers. This experiment provided the first evidence that heteromeric CK/EK is present in any source and the activity of CK/EK in the cell is controlled not only by the level of each isoform but also by their combination to form the active oligomer complex.

Molecular Cloning of Choline/Ethanolamine Kinase Genes

The first CK gene (*CKI*) was cloned from yeast in 1989 by complementation of *cki* mutants (Hosaka et al., 1989). The ORF encodes a protein of 582 amino acids. The transformed *E. coli* cells expressing the cloned gene displayed both CK and EK activities, indicating both activities could be encoded from the same gene in yeast. Since some residual EK activity was observed in the null mutant (*cki*) in which *CKI* gene was disrupted, it was suggested that another gene coding for a specific EK might be present. In 1992, a human CK cDNA was cloned by complementation of yeast mutants (*cki*) (Hosaka et al., 1992). The deduced protein has 456 amino acids. The C-terminal region, but not the N-terminal part, has a similarity to that of yeast CK. A phosphotransferase consensus sequence was found in the C-terminal part of both human and yeast CK, indicating that this region is conserved and may be involved in the catalysis. At the same

time, cloning of a rat *CK* cDNA (*CKR1*) was reported by screening a rat liver cDNA library with an antibody raised against highly purified rat liver CK (Uchida and Yamashita, 1992b). The cDNA encodes a protein of 435 amino acids. It is very similar to yeast CK. The enzyme from the cell extract of *E. coli* expressing the *CKR1* was found to have both CK and EK activities. Since the order of mRNA abundance in several rat tissues did not match the order of the activity level in these tissues, it was suggested that the rat cDNA cloned in this study might encode only one of the several CK isoforms in mammalian tissues. Two years later, the second *CK* cDNA (*CKR2*) was isolated from rat liver (Uchida, 1994). Since a single copy of *CKR* gene was revealed in the genome by Southern blot, it was believed that the *CKR2* is generated from *CKR* gene by an alternative splicing. The *CKR* gene was found to have a variety of putative *cis*-acting motifs, indicating a potential transcriptional regulation by a number of factors.

In 1994, an *EK* gene was isolated from *Drosophila* using an EK-defective mutant (Pavlidis et al., 1994). The cDNA contains an ORF encoding a protein of 495 amino acids. The C-terminal region of the deduced protein has high similarity to that of the CK/EK from yeast, human and rat, and it contains a putative kinase domain. A mutation in the *EK* gene due to a 2 bp deletion in the mutant cDNA results in a frameshift in the ORF, creating a stop codon within the reading frame. The altered transcript is predicted to produce a protein that contains only the first 260 amino acids of the putative full-length protein. This shorter protein lacked the highly conserved kinase domain in the C-terminus required for enzyme activity. The mutant flies display an easily shocked phenotype (“eas” or paralytic mutants). The eas mutants lose EK activity completely, but have normal CK activity. This study provides direct evidence that EK is different from

CK in *Drosophila*, and the defect in EK activity results in a sensitivity defect in this species. This defect may be due to the reduced ratio of PE/PC in the membranes. This phenomenon may be unique in *Drosophila* since PE comprises about 55% of its total membrane phospholipids, which is much higher than in most other eukaryotic organisms.

In 1996, three choline kinase-like cDNA clones were isolated from soybean using an EST from *Arabidopsis* that displayed sequence homology to mammalian and yeast choline kinases (Monks et al., 1996). Two of the three cDNAs were distinct and each of them shared approximately 32% identity at the predicted amino acid level with the rat choline kinase. A third unique choline kinase-like cDNA was also identified but was not full length. Heterologous expression of the first and second clone in yeast or *E. coli* demonstrated that each had choline kinase activity. In addition to choline, ethanolamine, monomethylethanolamine and dimethylethanolamine could also serve as substrates for the two choline kinase isoforms. Both soybean choline kinase isoforms demonstrated negligible ethanolamine kinase activity. Competitive inhibition assays revealed very distinct differences in their responses to monomethylethanolamine and dimethylethanolamine. These results provide evidence that choline kinase is encoded by a small, multigene family in soybean comprising two or more distinct isoforms that display both similarities and differences with regard to substrate specificity.

In summary, the study on EK/CK has not been conducted as intensively as the second enzyme, ECT, in the CDP-ethanolamine pathway. There is considerable evidence that EK may be rate-limiting in the pathway. Further investigation may help elucidate how much the EK contributes to the regulation of CDP-ethanolamine pathway for PE biosynthesis. These future studies may include: a search for existence of an EK-specific

gene in eukaryotic species, identification of all the isoforms and genes and the role of each isoform in PE biosynthesis, and better understanding of the mechanism of EK induction in various situations of the cells. The molecular cloning of EK isoforms may provide a fundamental tool for studies of the specific roles of each isoform using mutational strategy and corresponding genetic study of the cells in various organisms.

b. CTP: Phosphoethanolamine Cytidylyltransferase

ECT and CCT Study in Mammalian and Plant Cells

The three enzymes involved in the CDP-ethanolamine pathway have similar activities to those in the CDP-choline pathway. However, the protein structure and regulatory properties of ECT have been studied much less extensively as compared to the analogous enzyme, CTP: phosphocholine cytidylyltransferase (CCT) [EC 2.7.7.15] that catalyzes the second step in the CDP-choline pathway of PC biosynthesis. Although ECT has been assumed to be regulated like CCT, there is accumulating evidence that the control mechanisms for the ECT and CCT activities are different (Vermeulen et al., 1993).

The CDP-choline pathway consists of three enzymes: choline kinase (CK) [EC 2.7.1.32], CCT and cholinephosphotransferase (CPT) [EC 2.7.8.2]. CK and CPT in mammals have been purified and their structures elucidated by analyzing their cDNA clones (Weinhold et al., 1986; Kalmer et al., 1990, 1994). CCT, which catalyzes synthesis of CDP-choline in the CDP-choline pathway, has been extensively studied. It has been established that CCT is a key regulatory enzyme in the CDP-choline pathway (Kent, 1990; Clement and Kent, 1999; Cornell and Northwood, 2000). The sequences have been determined for several mammalian *CCT* cDNAs (Kalmar et al., 1990;

Rutherford et al., 1993; Sweitzer and Kent, 1994; Kalmar et al., 1994). The *CCT* gene from yeast has also been sequenced (Tsukagoshi et al., 1987). CCT is an amphitropic enzyme that exists in both an inactive soluble form and an active membrane-bound form. Regulation of the translocation process by changes in the lipid composition of cellular membranes seems to be one of the major mechanisms for the control of CCT activity (Cornell and Northwood, 2000). The exact molecular mechanism is not clear, but, phosphorylation and dephosphorylation of CCT appear correlated to the translocation of CCT to membranes; the soluble form is highly phosphorylated, and translocation of CCT to membranes is accompanied by extensive dephosphorylation. The role of phosphorylation of CCT in PC biosynthesis during the cell cycle has been investigated (Jackowski, 1994). In this study, it was concluded that CCT dephosphorylation accelerates PC synthesis in response to increased membrane phospholipid degradation to maintain membrane phospholipid mass during G1 phase, and inactivation of CCT associated with hyperphosphorylation of the protein during G2/M likely plays a role in the cessation of net membrane accumulation prior to cell division. A number of phosphorylation sites have been identified in CCT, and it was found that only serine residues at the C-terminus were phosphorylated (MacDonald and Kent, 1994). The membrane location has been thought to be the endoplasmic reticulum (ER), but in some cases may be nuclear (Morand and Kent, 1989; Watkins and Kent, 1992; Wang et al., 1995). The significance of the nuclear localization of CCT in some cells in terms of cellular regulation of PC synthesis is not clear (Wang et al., 1993). However, recent evidence reveals that the major isoform of CCT, CCT alpha that is localized in the nucleus of many cells, is recruited by signals that stimulate PC synthesis from an inactive

nuclear reservoir to a functional site on the endoplasmic reticulum (Cornell and Northwood, 2000). CCT is thought to have a bipartite structure composed of a N-terminal catalytic domain and an extended C-terminal domain. Between the catalytic domain and the phosphorylation region is a sequence that is predicted to form amphipathic-helices and to interact with the membrane bilayer of activating phospholipids (Craig et al., 1994; Wieder et al., 1994).

CCT cDNAs from plants have been cloned from *Brassica napus*, *Arabidopsis thaliana* and *Pisum sativum* (Nishida et al., 1996, Choi et al., 1997, Jones et al., 1998). The regulation mechanism of CCT in plants is not clear. It seems that the regulatory elements of the gene in plants differ from those in mammals and its function may be involved in many cellular processes such as cell proliferation and stress responses (Wang and Moore, 1989, 1990; Choi et al., 1997; Choi et al., 2001).

Previous Study of ECT Subcellular Localization

It was generally believed that ECT of mammalian cells was a soluble enzyme that did not associate with cellular membranes. This conclusion was based on classical differential centrifugation studies and enzyme-release measurements from digitonin-permeabilized hepatocytes that demonstrated that ECT, unlike CCT, is not associated with cellular organelles (Vermeulen et al., 1993). In 1994, an immunogold electron microscopy study on the cellular localization of ECT in rat liver was performed using a polyclonal affinity-purified antibody against the enzyme (van Hellemond et al., 1994). It was concluded that ECT label was concentrated in cisternae of the rough ER. Other cellular organelles, including nuclei, mitochondria and plasma membranes, were only marginally labeled. Double-label experiments for ECT and markers for either soluble or

integral ER proteins suggested a bimodal distribution of ECT between the cisternae of rough ER and the cytosol. These findings led to the suggestion that ECT might reversibly interact with membranes of the ER, and thus bring the enzyme close to the final enzyme of this pathway, ethanolaminephosphotransferase, which is known to be an integral microsomal protein (Vance and Vance, 1988). Unlike these investigations, in castor bean endosperm ECT was found to be located in both the mitochondria and the ER (Wang and Moore, 1991; Tang and Moore, 1997). In these studies using castor bean endosperm, the highest activity was found to be mitochondrial and tightly bound to the outer membrane of this organelle. No soluble activity was found. These findings indicate that the subcellular localization of ECT enzyme may be different between mammals and plants. This may further imply that the regulation model proposed for mammalian systems is unlikely to apply for plants. The study of ECT regulation in plant cells may help clarify this difference in regulation of ECT activity in different organisms.

Possible ECT Regulation Mechanisms in Mammalian Cells

A number of studies have concentrated on which step(s) in the CDP-ethanolamine pathway could provide an important contribution to the overall metabolic regulation of the process. On the basis of theoretical considerations, it was suggested that both the first reaction, catalyzed by ethanolamine kinase, and the second catalyzed by ECT, could be regulatory steps in rat liver (Infante, 1977). Exposure of hepatocytes to increasing concentrations of ethanolamine results in enhanced entry of labeled glycerol into PE and this was accompanied by a considerable increase in the pool size of phosphoethanolamine while the pool size of CDP-ethanolamine remained constant (Sundler and Akesson, 1975). These observations suggest that the reaction catalyzed by ECT is likely to be a

potential regulatory site in PE biosynthesis via the CDP-ethanolamine route. Studies by Tijburg et al (Tijburg et al., 1987) provided further evidence for such a role of ECT by showing that exposure of hepatocytes to phorbol esters led to an increased rate of incorporation of labeled ethanolamine into PE, increased activity of ECT, a reduction in the pool size of phosphoethanolamine, and an enhanced conversion of CDP-ethanolamine into PE. It appears that under most conditions the supply of CDP-ethanolamine is a principal factor controlling the rate of PE synthesis.

In the case of CCT, it has been found that the subcellular organization of the enzyme is a major factor in regulating the activity of this enzyme and that of the CDP-choline pathway (Kent, 1995). The soluble form of CCT appears to represent an inactive reservoir from which the enzyme can rapidly and reversibly translocate to cellular membranes or the nuclear envelope where it becomes activated by interactions with lipids (Vance, 1996; Cornell and Northwood, 2000). A comparable translocation mechanism for regulation of the activity of ECT, the putative key-regulatory enzyme in the CDP-ethanolamine pathway, was thought to be unlikely as it was generally accepted that ECT of mammalian cells was a fully soluble enzyme that did not bind significantly to membranes. In addition, the activity of ECT is not stimulated by interactions with lipids (Vermeulen et al., 1993). However, the immunogold electron microscopy studies which demonstrated that ECT was present predominantly in rough ER-rich areas of hepatocytes, and that within these areas the enzyme partitioned between ER membranes and the cytosol, suggest otherwise (van Hellemond et al., 1994). An early observation that phosphoethanolamine formed from exogenous ethanolamine did not freely equilibrate with the endogenous liver phosphoethanolamine pool has indicated that the product of the

ethanolamine kinase reaction may be specifically channeled towards ECT (Sundler, 1973). Since the final enzyme in this pathway, ethanolaminephosphotransferase, is an integral microsomal enzyme, reversible binding of ECT to the membrane could play a key role in the regulation of the CDP-ethanolamine pathway. The compartmentalization of the aqueous precursors in the CDP-ethanolamine pathway was supported by a recent study (Shiao and Vance, 1995).

Early Characterization of ECT Protein

In 1975, ECT was purified 1000-fold from a post-microsomal fraction of rat liver by Sundler (Sundler, 1975). Vermeulen *et al* (1993) purified ECT to homogeneity from rat liver and got a 1400-fold purification of ECT with a final specific activity of 6.5 $\mu\text{mol}/\text{min}/\text{mg}$. Polyacrylamide gel electrophoresis under denaturing and reducing conditions showed the presence of a single protein band with an estimated molecular mass of 49.6 kDa. In yeast, the presence of the same enzyme activity was reported (Nikawa *et al.*, 1983), but the properties and regulation of the enzyme remain unclear. The ECT purified by Sundler showed a sharp pH optimum at 7.8, with a broader one around 6 with lower maximal activity (Sundler, 1975). This may indicate that ECT contains a second binding site for phosphoethanolamine. The requirement of ECT for a divalent cation was found to be absolute with Mg^{2+} at 5 to 10 mM being most efficient; the activity of ECT was reduced if Mg^{2+} was replaced by optimal concentrations of Mn^{2+} , Ca^{2+} or Co^{2+} while other divalent cations, including, Ba^{2+} , Zn^{2+} , Cd^{2+} , Ni^{2+} , were not effective. The K_m values were 65 and 53 μM for phosphoethanolamine and CTP, respectively. An ordered sequential reaction mechanism was proposed with CTP being the first substrate to bind to the enzyme and CDP-ethanolamine the last product to be

released (Sundler, 1975). PE biosynthesis in castor bean endosperm has been well studied (Sparace et al., 1981; Shin and Moore, 1990a, 1990b; Wang and Moore, 1991, Tang and Moore, 1997). It was shown that about 80% of the ECT activity occurs in mitochondria and the rest in ER. The mitochondrial location of ECT was detected largely in outer membrane fractions. Both mitochondrial and ER ECT require cations for activity with Mg^{2+} preferred over Mn^{2+} and Ca^{2+} . The optimal pH was 6.5 for both mitochondrial and ER ECTs. The apparent K_m values for phosphoethanolamine were 143 and 83 μM and those for CTP were 125 and 101 μM for the mitochondrial and ER activities, respectively (Wang and Moore, 1991).

Molecular Cloning of the ECT Gene

The ECT gene or its cDNA has been cloned to date from *Saccharomyces cerevisiae* (*ECT1*) (Min-Seok et al., 1996), *Homo sapiens* (cDNA) (Nakashima et al., 1997) and *Rattus norvegicus* (cDNA) (Bladergroen et al., 1999). The human ECT protein (389 amino acids) was found to have 34% identity to the yeast protein (323 amino acids), while rat ECT (404 amino acids) was 88% identical to that of human. Both human and rat ECTs are longer than the yeast ECT protein in both the N- and the C-terminal regions. There is a large repetitive sequence in the N- and C-terminal halves of human, rat and yeast ECT. Both parts of the repetitive sequence contain the HXGH motif, which is also present in the most conserved region of the N-terminus of members of the cytidyltransferase superfamily (Bork et al., 1995) as well as class I aminoacyl-tRNA synthetases (Delarue and Moras, 1993). Because this motif is thought to be associated with the active site of these proteins (Park et al., 1997), two catalytic domains could be predicted for ECT. This is consistent with earlier observations from kinetic

studies with purified rat liver (Vermeulen et al., 1994) as well as the pH profile by Sundler (1975). In the first study, two K_m values for the binding of phosphoethanolamine to ECT were found suggesting the existence of two binding sites for phosphoethanolamine, and the second study demonstrated two pH optima, consistent with this interpretation. In addition, the sequence RTQXGVSTT, which was considered a signature sequence for the cytidylyltransferase family (Park et al., 1997), is found in the ECT of all three organisms.

The hydropathy profiles of all three cloned ECTs (yeast, rat and human) show that the overall amino acid sequence is predominantly hydrophilic. There was no prediction of either hydrophobic helical regions long enough to span a lipid bilayer or amphipathic helical structures. Although immunogold electron microscopy studies indicated that rat ECT is enriched in areas rich in rough ER (Van Hellemond et al., 1994), and there is preliminary evidence that yeast ECT might be associated directly with the ER membrane (Min-Seok et al., 1996), it is unlikely that ECT protein in rat, yeast or human interacts with the lipid component of the ER membrane since the overall sequence of ECT proteins is hydrophilic and does not contain amphipathic α -helix domains. It has been suggested that ECT may associate with the ER membrane through protein-protein interaction with one of the proteins in the membrane, e.g. the final enzyme in this CDP-ethanolamine pathway, EPT, permitting the efficient channeling of intermediates involved in the pathway for PE biosynthesis (Bladergroen et al., 1998). The mechanism for the putative interaction of ECT with ER membrane or ER-membrane protein remains to be elucidated.

Up to now, there is little information on regulation of PE synthesis or ECT

activity at the level of gene expression. It was observed that the amount of *ECT* mRNA, as expressed relative to the abundance of β -actin mRNA, increased during the development of rat liver, indicating that rat ECT might be regulated at the level of mRNA expression (Bladergroen et al., 1999). How this enhanced ECT mRNA level influences ECT activity is unclear. In this study, it was suggested that ECT activity may be regulated both pre- and post-translationally since the changes in measured ECT activity did not completely match those in *ECT* mRNA levels. The mechanisms for these possible regulatory steps remain to be determined.

No ECT cDNA has been cloned from plants. The molecular cloning of ECT cDNA should be the first step in elucidating the relationship between the structure and the function of ECT. The availability of the ECT sequence would allow the future characterization of the protein and the manner in which its activity is regulated. It would be interesting to know if the plant ECT gene has the same structure as that in yeast or mammalian cells, and if it is regulated in the same way as proposed to other species.

Overall, progress in the understanding of ECT has been much less than that of the simultaneously discovered CCT enzyme. However, recent studies have revealed a number of new metabolic roles of PE in eukaryotic cells, including production of second messengers in signal transduction, formation of the phosphoethanolamine bridge that links the glycosylphosphatidylinositol anchor to surface glycoproteins of eukaryotes, generation of *N*-acyethanolamine that functions in neurotransmission of brain, regulation of cytokinesis and mediation of lipid homeostasis (Mukherjee et al., 1996; Menon and Stevens, 1992; Devane et al., 1992; Umeda and Emoto, 1999; Dobrosotskaya et al., 2002). This has increased interest in the study of PE metabolism and its regulation in

eukaryotic cells.

c. DAG:CDP-ethanolamine Ethanolaminephosphotransferase

Discovery, Localization and Purification

CDP-ethanolamine: 1, 2-diacylglycerol ethanolaminephosphotransferase (EPT) catalyzes the final reaction of the CDP-ethanolamine pathway for the *de novo* synthesis of PE. It was first described by Kennedy and Weiss in their original study of the role of cytidine nucleotides in the synthesis of phospholipids (Kennedy and Weiss, 1956). Less progress has been made in studying the biological function of EPT and PE synthesis than that in studying the enzymes in the Kennedy pathway for PC synthesis, mainly due to the limited knowledge about the biological roles of PE. PC has been shown to be an effective source of signaling molecules and its roles in the biogenesis of several major metabolites in mammalian cells and tissues have been verified. In addition, the phenomena associated with choline deprivation are well-established. In contrast, there are no known biological phenomena associated with ethanolamine deprivation and until recently very few studies have explored the role of PE as a source of lipid-derived second messengers. No eukaryotic cells have been found as ethanolamine auxotrophs, presumably their CDP-ethanolamine pathway precursors are derived through metabolism of sphingolipids (Spiegel and Merrill, 1996).

EPT activity has been found in all eukaryotic cells. The tissue distribution of EPT specific activity in mammals revealed the highest levels in the liver and brain, then in intestine and the lowest in skeletal muscle (Coleman and Bell, 1977). In eukaryotic cells, the majority of *de novo* PE synthesis is via the CDP-ethanolamine pathway although the PS decarboxylation and base exchange reaction may contribute to various extents

(Sundler et al., 1974; Zelinski and Choy, 1982; Tijburg et al., 1988; McMaster and Choy, 1992; Achleitner et al., 1995). EPT is absent in prokaryotes which synthesize PE exclusively *via* the decarboxylation of PS (McMaster and Bell, 1997).

The site of PE biosynthesis is usually determined by the intracellular location of EPT enzyme. EPT activity has been found consistently associated with the microsomal membrane fraction. Most studies show that EPT locates in the ER. However, variable contributions from other organelles, such as the Golgi, have been reported, depending on the subcellular fractionation and enzyme assay methods used (Vance and Vance, 1988). An integral membrane localization of EPT has been suggested based on the observation that EPT activity cannot be obtained from biological membranes without adding detergents that usually completely dissolve the membrane bilayer and by supplementing the dilution medium with phospholipids and adding Mn^{2+} ions to the dispersion buffer the stability of EPT was increased (Mancini et al., 1993). Results consistent with the integral membrane location of EPT in mammalian cells were obtained with the EPT enzyme of the *S. cerevisiae* (EPT1). It was shown that EPT1 has an absolute requirement for phospholipids and contains seven transmembrane domains predicted at its deduced amino acid sequence level (Hjelmstad and Bell, 1991a; Hjelmstad and Bell, 1991b; McMaster et al., 1996). Results from studies using protease in treatment of the hepatic microsomal membranes indicated that both EPT and CPT active sites faced the cytoplasm and biosynthesis of PE and PC occurs asymmetrically on the cytoplasmic surface of the ER (Vance et al., 1977; Coleman and Bell, 1978).

EPT has not been purified from any cell type mainly because of the complications from solubilization and the subsequent activity recovery by the addition of lipids or the

removal of excess detergent. Since EPT is an integral membrane protein, the early step in purification usually requires the complete solubilization of the lipids in the biological membranes for extraction. However, EPT activity is sensitive to detergents which generally inactivate the enzyme activity completely. Although several attempts to reconstitute the activity after membrane solubilization have succeeded, the enzyme is labile and not suitable for the numerous column chromatography steps required for the preparation of a pure protein (Tijburg et al., 1989b; Mancini et al., 1993). It may be anticipated that the purification may be improved when the *EPT* cDNA is available through overexpression of the protein with an appropriate affinity tag in a proper host organism.

Substrate Specificity and Regulation

It is generally believed that EPT does not regulate the rate of PE synthesis in the CDP-ethanolamine pathway, and PE synthesis is regulated at the level of ECT (Sundler and Akesson, 1975; Tijburg et al., 1988). It may be predicted that the supply of CDP-ethanolamine should affect the steady-state levels of EPT activity *in vivo*. However, by changing the supply of the other substrate for EPT, diacylglycerol, the PE synthesis was found limited. Decreasing diacylglycerol levels by treatment of hepatocytes with glucagons or cAMP analogues decreased PE synthesis via the CDP-ethanolamine pathway, which is consistent with a rate-limiting role for EPT (Tijburg et al., 1989a). Consistent results also were obtained in a study of the CDP-choline pathway for PC synthesis, and showed that diacylglycerol levels inhibited by glucagon or cAMP mediation were able to limit PC synthesis at the level of cholinephosphotransferase, not at the level of CTP: phosphocholine cytidyltransferase (Jamil et al., 1992).

There has been evidence to show that EPT and CPT are separate enzymes with distinct activities in animal cells. The partially purified phosphotransferases from ion-exchange chromatography displayed a higher sensitivity than microsomal phosphotransferases to exogenous phospholipids and showed an absolute requirement for divalent cations. Upon purification, cholinephosphotransferase was more stable to heat treatment than ethanolaminephosphotransferase. The two enzymes exhibited distinct pH optima and responded differently to exogenous phospholipids (O et al., 1989). Genetic evidence obtained through the isolation of hamster ovary cells defective in EPT activity revealed that EPT is encoded by a gene different from CPT (Polokoff et al., 1981). In this study, the enzyme assays of these mutant cells showed a six-fold decrease in EPT activity while CPT activity was unaffected.

Most of our knowledge about EPT regulation has been obtained from the study of the enzyme in *S. cerevisiae*. Yeast has both a cholinephosphotransferase (CPT1) and an ethanolaminephosphotransferase (EPT1), which are encoded by two genetic loci, *CPT1* and *EPT1*, respectively. EPT1 can be cosolubilized with its substrate diacylglycerol by using the detergent Triton X-100 for the formation of mixed micelles. Yeast mutants (*ept1*) defective in EPT1 activity combined with analysis of the enzyme activity have allowed for the characterization of substrate specificities (Hjelmstad and Bell, 1991a; McMaster et al., 1996). It was observed that yeast EPT1 was able to efficiently utilize CDP-ethanolamine, CDP-monomethylethanolamine, CDP-dimethylethanolamine and CDP-choline. The broad range of substrate specificity suggested that the EPT1 in yeast might synthesize both PE and PC *in vivo*. However, *in vivo* labeling studies using yeast mutants (*ept1*, *cpt1*) defective in either EPT1 or CPT1 showed that the EPT1 utilized

CDP-ethanolamine almost exclusively and only about 5% of net PC synthesis was from the contribution of EPT1 and this PC synthesis was decreased by addition of ethanolamine to the media (McMaster and Bell, 1994; McGee et al., 1994). This implies that the cellular levels of CDP-ethanolamine affect the PC synthesis by EPT1. Studies using the CPT1/EPT1 chimeric enzyme indicated that the domain conferring the EPT1 selectivity in PE synthesis matched the CDP-aminoalcohol binding domain and that enzyme recognition of the fatty acyl moieties of the DAG substrate and phospholipid activator were fundamentally different (McMaster and Bell, 1994; Hjelmstad et al., 1994). These studies also suggested the involvement of discontinuous protein segments participating in the interaction with phospholipid cofactors based on the analysis of chimeric enzyme dependence on phospholipid activators. It is possible that some other factors may also contribute to the control of EPT1 in PC synthesis. A recent study suggested that intracellular diacylglycerol pools are not equally accessible to both EPT and CPT of fibroblasts (Igal and Coleman, 1996).

An essential requirement for divalent cations by the EPT1 in yeast was reported and among the cations tested only Mg^{2+} , Mn^{2+} and Co^{2+} were found able to stimulate the enzyme activity (Hjelmstad and bell, 1991b; McMaster et al., 1996). Similar cation activation profiles for mammalian EPT activity were observed (Tijburg et al., 1989a). The precise mechanism of cation activation is not known. Several possibilities have been proposed including formation of a complex between CDP-ethanolamine and cation, and interactions between cation and a specific region of the enzyme (McMaster and Bell, 1997). Studies using the *CPT1/EPT1* chimeric enzymes demonstrated that disparate regions of the protein other than those in the active site were required for cation

activation (McMaster et al., 1996). The role of Ca^{2+} in EPT activity in yeast has not been investigated.

An absolute requirement for phospholipids by EPT has been reported in yeast and one or more distinct phospholipid binding sites in the enzyme were predicted (Hjelmstad and Bell, 1991b; McMaster et al., 1996). These studies showed that the specific activity of EPT1 with either CDP-ethanolamine or CDP-choline as substrate is affected by the phospholipids present in the mixed micelle. PC is an efficient activator of EPT1 regardless of whether the substrate is CDP-ethanolamine or CDP-choline. In contrast, PE is a weak activator of EPT1 but a better activator of CPT1 enzyme. This difference in phospholipid activation profiles by PC and PE would allow for a model that predicted that an increase in PE production would result in a decreased efficiency for use of CDP-ethanolamine over CDP-choline. The local concentrations of PE and PC both as the products of EPT1 dual activity in the vicinity of EPT1 enzyme would be expected to have dramatic effects on its activity. Thus, product formation may affect substrate specificity *in vivo*. The structural requirements for lipid activation of EPT1, which are identical to those for CPT1, include a phosphoester bond at the *sn*-3 position, proper intercalation of the head group into the surface of the micelle, and differences in activation ability based on head group specificity (McMaster et al., 1996). It has been observed that EPT is inhibited by one of its products, CMP, in both mammals and yeast (Tijburg et al., 1989a; Mancini et al., 1993; Hjelmstad et al., 1994). The physiological significance of this inhibition by CMP is not known.

The two enzymes, CPT and EPT, seem to be distinct in their activities in PC and PE synthesis of yeast and animals (Bell and Coleman, 1980; Percy et al., 1984).

However, it has been unclear whether CPT, EPT or both in higher plants could utilize both CDP-choline and CDP-ethanolamine to synthesize the corresponding PC or PE. A number of early studies have indicated a single enzyme is capable of synthesizing both PC and PE in higher plants (Macher and Mudd, 1974; Lord, 1975; Sparace et al., 1981; Justin et al., 1985). The convincing evidence for the dual functional activities of single enzyme in PC and PE synthesis in plants is from the recent molecular cloning of several plant aminoalcoholphosphotransferase cDNAs and characterization of the expressed enzyme in yeast mutants deficient in both CPT1 and EPT1 activities (Dewey et al., 1994; Goode and Dewey, 1999). In these studies, it was demonstrated that both PC and PE could be synthesized by a single enzyme that utilized both CDP-choline and CDP-ethanolamine as substrates.

Molecular Cloning and Characterization

The first *EPT* gene was isolated from *S. cerevisiae* (*EPT1*) by using yeast mutants defective in EPT activity and complementation of the mutants with a yeast library (Hjelmstad and Bell, 1988, 1991a). Only one *EPT1* gene was found in the yeast and *in vitro* EPT1 activity was demonstrated (Hjelmstad and Bell, 1991a; McMaster and Bell, 1994). In 1994, a cDNA coding for an aminoalcoholphosphotransferase in soybean (AAPT1) was cloned with notably high cholinephosphotransferase activity (Dewey et al., 1994). The deduced amino acid sequence of soybean AAPT1 was equally similar to both EPT1 and CPT1 sequence of yeast. The substrate specificity of the AAPT1 *in vivo* has not been investigated. In 1999, two cDNAs (*AtAAPT1*, *AtAAPT2*) coding for two EPT isoforms in *A. thaliana* were isolated (Goode and Dewey, 1999). The substrate specificities of the two enzymes (*AtAAPT1* and *AtAAPT2*) were defined after they were

expressed in a yeast strain deficient in aminoalcoholphosphotransferase activities. It was found that although each isoform was able to incorporate both CDP-ethanolamine and CDP-choline into PE and PC, respectively, AtAAPT2 has a greater preference for CDP-choline over CDP-ethanolamine in comparison to AtAAPT1. AtAAPT1 demonstrated similar degrees of inhibition by Ca^{2+} and CMP to a soybean AAPT1 that was characterized previously by the same group (Dewey et al., 1994), while AtAAPT2 was inhibited to a lesser degree by these factors. All three aminoalcoholphosphotransferases were found capable of catalyzing the reverse reaction producing CDP-choline and diacylglycerol from PC in the presence of CMP. Transgenic tobacco overexpressing the soybean *AAPT1* cDNA had only slight increases in enzyme activity, indicating the possible presence of posttranscriptional regulation (Goode and Dewey, 1999). A human choline/ethanolaminephosphotransferase cDNA (*hCPT/EPT1*) was also cloned and characterized (Henneberry and McMaster, 1999). The ORF encoded a 416 amino acid protein containing seven membrane-spanning domains. An amphipathic helix was predicted in the active site of the enzyme with the last two aspartic acid residues in the CDP-alcohol phosphotransferase motif, D-G-x(2)-A-R-x(8)-G-x(3)-D-x(3)-D, located in this helix. The enzyme from hCPT/EPT1-expressed in a yeast strain devoid of both CPT1 and EPT1 activities was able to utilize both CDP-ethanolamine and CDP-choline as substrates in synthesis of PE and PC both *in vitro* and *in vivo*. The cDNAs coding for two aminoalcoholphosphotransferase isoforms in Chinese cabbage (*Brassica campestris* L. var. *pekinensis* Makino) (AAPT1 and AAPT2) have also been cloned (Min et al., 1997; Choi et al., 2000). A 95% identity was found between the two isoforms at the level of deduced amino acids. It was demonstrated that isoform AAPT2 was regulated

temporally and upregulated by low temperature by use of an RT-PCR test. An aminoalcoholphosphotransferase (AAPT1) from *Brassica napus* was also cloned and characterized with results indicating that expression of *Brassica napus* AAPT1 in transgenic *Arabidopsis* increased tolerance to abscisic acid and low-temperature stress (Qi et al., 2003).

The availability of the *EPT1* gene sequence in yeast has allowed for the precise analysis of the gene structure in comparison to the similar gene *CPT1* (Hjelmstad and Bell, 1991b). There is 56% amino acid sequence identity between EPT1 and CPT1. The predicted structure of EPT1 protein is very similar to that of CPT1 with respect to membrane topography, transmembrane asymmetry, and features of secondary structure, suggesting a structural basis for location of the EPT1 active site on the cytoplasmic side of microsomal vesicles, and an evolutionary relationship between the functionally related EPT1 and CPT1 proteins. The *EPT1* gene was found to contain an intron near its 5' end and a single 1.4 kb transcript was detected. The intron contains splicing signals at each end typical of those in yeast. The analogous splicing signals were also found in the counterpart *CPT1* gene and these introns in both *EPT1* and *CPT1* genes disrupt the same codon at the same site, indicating the two genes may have arisen from a duplication event. The *EPT1* gene has several TATA elements upstream of the coding region as well as two consensus transcription termination sequences in the 3' flanking region. Abundance of the *EPT1* transcript was decreased by the addition of inositol to the media (Morash et al., 1994). In yeast, inositol is a general regulator of many genes at the level of transcription in the biogenesis of fatty acids and phospholipids through the activation of inositol-regulated transcription factors which bind to the motif CATGTGAAAA

(Hjelmstad and Bell, 1991a). The *EPT1* gene contains this motif with one substitution, CATGAGGAA. However, inositol-dependent transcriptional regulation of the *EPT1* gene was not observed in CPT1-defective mutants (*cpt1*), suggesting a coordinate regulation may exist between the two genes (Morash et al., 1994). The CDP-aminoalcohol-binding domain of EPT1 protein was found similar to many other phospholipids-synthesizing enzymes, each of which catalyzes the formation of a phosphoester bond from a CDP-alcohol and a second alcohol with the release of CMP. A conserved motif, which was designated the CDP-alcohol phosphotransferase motif, D-G-x(2)-A-R-x(8)-G-x(3)-D-x(3)-D, was contained in the active site of EPT1. This motif is conserved in all enzymes that catalyze the same type of reaction and is considered to be diagnostic of this reaction.

EPT has not been purified from any cell type. The isolation of yeast mutants defective in both CPT1 and EPT1 activities has provided an effective means for isolation and characterization of mammalian and plant aminoalcoholphosphotransferase genes. The biological functions of PE other than being a major membrane component in maintaining membrane integrity recently have been studied more intensively. The studies of the EPT functions will help further elucidate the role of phospholipid composition and function during growth and development of eukaryotic organisms.

The objective of this research was to obtain the cDNA and genomic sequence of the two genes that code for the two proteins, ECT and EPT, from *C. reinhardtii*, and to characterize the products of the two genes in terms of their structure, function and regulation in *C. reinhardtii* cells.

CHAPTER 2

INVESTIGATIONS ON CTP: PHOSPHOETHANOLAMINE CYTIDYLYLTRANSFERASE

Materials and Methods

Restriction endonucleases and other DNA modifying enzymes were from New England BioLabs (Massachusetts, USA). Primers were made by Integrated DNA Technologies (Coralville, Indiana, USA). CTP, phosphoethanolamine and CDP-ethanolamine were purchased from Sigma-Aldrich. All other chemicals were of reagent grade.

a. cDNA Library Preparation

A cDNA library in plasmids was prepared from the core cDNA library in Lambda Zap II phage purchased from the Chlamydomonas Genomics Project (Duke University, North Carolina, USA). The cDNAs in Lambda Zap II phage were transformed in *E. coli* by using a ZAP-cDNA Synthesis Kit (Stratagene, Valencia, CA) as described by the manufacturer. *E. coli* colonies were pooled for plasmid preparations that were used as templates in PCR-based cDNA cloning of ECT.

b. cDNA Cloning and DNA Sequencing

Rat and human ECT protein sequences (accession numbers NP_446020 and NP_002852) were used to search the *C. reinhardtii* expressed sequence tag (EST) database (http://www.biology.duke.edu/chlamy_genome) to find highly homologous EST clones (see Appendix Table A1). These EST clones were assembled into two separate contigs that corresponded to the N- and C-terminal sequences of ECT in human, rat and yeast. The translated contig sequences were then compared to the human, rat and yeast

ECT protein sequences in GenBank confirming that the contig had a high degree of similarity to these ECT proteins. The two contigs contain putative start and stop codons, based on the translated sequence analysis. Primers were designed to clone the coding region of cDNA from the library prepared above. The primers that successfully produced the correct cDNA by PCR included forward primers 5'-TGA ACC GCG GTA ACC AAG CT-3', 5'-ATG GTC TTA CTC GAT TCG GTC-3', and reverse primers 5'-GCA TCA GTA ACC CTC ACA CG-3' and 5'-CAA CTC CTG CAC GTA CTG CTT-3'.

The PCR products spanning the complete *ECT* cDNA coding region were subjected to agarose gel electrophoresis and extracted from the gel using a QIAquick gel extraction kit (QIAGEN, Valencia, CA). The purified DNA fragments were sequenced on both strands using Applied Biosystems BigDye terminators (Foster City, CA, USA). The degenerate primers for sequencing the cDNA included forward primers 5'-CAC CAA GCA CCG GAT AGA TT-3' and 5'-ACC TGC CCA TCA GAA CCT-3', and reverse primers 5'-AAT CTA TCC GGT GCT TGG TG-3' and 5'-AGG TTC ATG ATG GGC AGG T-3', together with the primers used in the PCR. The 3' untranslated regions (UTR) were obtained by PCR using a pBluescript-KS vector-based primer, 5'-GTA AAA CGA CGG CCA GTG AAT-3', and a gene specific primer at the 3' end before the stop codon, 5'-ACC TGC CCA TCA TGA ACC T-3', and sequencing of the PCR fragment. In addition, contig alignment of the complete coding sequence of *ECT* cDNA and the ESTs for the *ECT* gene in the *C. reinhardtii* EST database was performed for 3' UTR and 5' UTR sequences. The complete coding region was also sequenced on both strands of the PCR product and was checked after it was cloned into an *E. coli* expression vector pMAL-c2X (New England BioLabs).

c. Sequence Analysis

Nucleotide and deduced amino acid sequences were compared with sequences in the databases at the National Center for Biotechnology Information (NCBI) by using the BLAST program (<http://www.ncbi.nlm.nih.gov/BLAST/>) (Altschul et al., 1990). Sequence analysis, alignments and phylograms were obtained by using the multiple sequence alignment programs from the European Bioinformatics Institute EMBL-EBI server (<http://www.ebi.ac.uk/clustalw/>). The Prosite database from EBI server (<http://ca.expasy.org/prosite/>) was used to find putative consensus motifs for specific domains in ECT.

d. Expression of *ECT* cDNA in *Escherichia coli*

Construction of MAL-fusion Protein

Two primers were designed with an adapter sequence of *EcoRI* or *HindIII* that amplified the complete coding region of cDNA. They were forward 5'-CGG AAT TCA TGG TCT TAC TCG AT-3' and reverse 5'-CCC AAG CTT TTC ACA ACT CCT GCA C-3'. The PCR product of 1.3 kb from these primers was digested with *EcoRI* and *HindIII* and then cloned into the *EcoRI/HindIII* site of an *E.coli* expression vector pMAL-c2X (New England BioLabs). The construct, designated as pMAL-ECT, was sequenced to confirm the correct translation frame. Competent *E. coli* DH5 α cells were transformed with pMAL-ECT. The fusion protein was produced by the transformed *E. coli* grown at 37°C in Luria-Bertani medium containing 50 μ g/mL ampicillin, and induced at an A_{600} of 0.7 with 0.2 mM isopropylthiogalactopyranoside (IPTG). After induction at 30°C for 12 h, the cells were harvested and the fusion protein purified with a pMAL protein fusion and purification system as described by the supplier (New England BioLabs). Cell

extracts of the IPTG-treated and untreated cells, plus purified fusion protein, were used for protein analyses. SDS-polyacrylamide gel electrophoresis (SDS-PAGE) was performed in 10% polyacrylamide mini-slab gels. Proteins were stained with Coomassie Brilliant Blue. Protein concentration was determined by the dye-binding method using Bio-Rad protein assay kits (Bio-Rad, Hercules, CA) with bovine serum albumin as a standard (Bradford, 1976).

ECT Activity Assay

ECT enzyme activity was measured as described (Sundler, 1975) in 50 μ L final volume containing 20 mM Tris-HCl (pH 7.5), 10 mM $MgCl_2$, 5 mM DTT, 2 mM CTP, 2 mM phosphoethanolamine and 20 μ L cell extract (30 μ g *E. coli* protein) or 10 μ L of purified protein (15 μ g). The mixture was incubated at 30°C for 30 min or as otherwise specified. The reaction was stopped by boiling for 5 min. The products were separated by thin-layer chromatography (TLC) on a Silica Gel 60 plate (E. Merck, Darmstadt, Germany) with 100% ethanol: 0.5% NaCl: 25% NH_4OH (50:50:5 by volume) as the developing solvent. After development, the plates were air-dried and then sprayed with ninhydrin contained in butanol. Spots corresponding to CDP-ethanolamine and phosphoethanolamine were detected by their bright purple color as compared with standards run on the same plates.

e. Southern and Northern Blot Analyses

Genomic DNA from *C. reinhardtii* wild type 137C was isolated as described (Rochaix, 1978). Five μ g of genomic DNA were digested with restriction endonucleases (New England BioLabs), resolved on an 0.8% agarose gel, transferred to a Nytran membrane (Schleicher and Schuell, Keene, New Hampshire), and hybridized with a

radiolabeled probe derived from the 0.4 kb PCR fragment of the 3' coding region of cDNA using primers, forward 5'-ACCTGCCCATCATGAACCT-3' and reverse 5'-CAACTCCTGCACGTACTGCTT-3'. The DNA transfer, hybridization and washes were as described (Sambrook et al., 1989). For Northern blots, cells of 137C strain were grown on Tris-acetate phosphate (TAP) medium with a 12-h /12-h light-dark cycle until the cell density reached $\sim 10^7$ cells per ml. The cells were deflagellated by pH shock (Witman et al., 1972). The flagella were removed and the cells resuspended in fresh TAP for reflagellation. Cell samples were taken at different times during reflagellation for total RNA isolation. Total RNA was isolated as described (Thompson and Mosig, 1984). Thirty μg of total RNA were electrophoresed on a 1% agarose gel containing formaldehyde, transferred to a Nytran membrane, and hybridized to the same probe used in the Southern blot as described (Sambrook et al., 1989).

f. Cell Fractionation with Sequential Centrifugation

The cell wall-deficient mutant strain of *C. reinhardtii* CC-406 cw15 (*mt⁻*) was grown in Tris-minimal phosphate medium (Harris, 1989) at 22°C, with bubbling of 5% CO₂ in air under continuous light. The cells were harvested in log phase by centrifugation at 1,000g at 4°C for 10 min, washed once with cold 20 mM Hepes-KOH (pH 7.5) at 4°C, and concentrated with a final centrifugation. The cellular fractionation was performed by sequential centrifugation of homogenates as described by Moore et al (Moore et al., 2001). All centrifugations were performed at 4°C, and the samples were kept on ice in all steps of the procedure. The protein concentration in each fraction was determined by the Bradford method using BSA as the standard (Bradford, 1976).

The cellular fractions were identified by the use of the marker enzymes Rubisco

for chloroplasts (Spreitzer et al., 1988), fumarase for mitochondria (Walk and Hock, 1977), and diacylglycerol: CDP-choline cholinephosphotransferase for endoplasmic reticulum (Moore, 1976). The ECT assay was conducted as described above except 100 µg protein and 30 µM ¹⁴C-phosphoethanolamine (54 mCi/mmoL) were used in the reaction. The radiolabeled CDP-ethanolamine produced in the enzyme assays was quantitated using liquid scintillation spectrometry after being recollected from the TLC plates.

g. Enzyme Activity during Cell Cycle

The cells of *C. reinhardtii* 137C were grown in Tris-minimal phosphate medium (Harris, 1989) at 22°C, with bubbling of 5% CO₂ in air with a 12-h /12-h light-dark cycle. After five days of cell growth under synchronization, samples of cells were taken at various times during a cell cycle. The total RNA and protein were isolated as described (Thompson and Mosig, 1984; Moyano et al., 1992). The Northern blot of total RNA and ECT enzyme assays were performed as described above.

h. Enzyme Activity at Different pH, Cations and Substrate Concentrations

The cell wall-deficient mutant strain of *C. reinhardtii* strain CC-406 cw15 (*mt⁻*) was grown in Tris-minimal phosphate medium (Harris, 1989) at 22°C, with bubbling of 5% CO₂ in air under continuous light. The cells were harvested in log phase by centrifugation at 1,000 g at 4°C for 10 min, washed once with cold 20 mM Hepes-KOH (pH 7.5) at 4°C, and concentrated with a final centrifugation. The total protein was isolated as described (Moyano et al., 1992). The protein concentration was determined by the Bradford method using BSA as the standard (Bradford, 1976). The fumarase activity of the protein preparations was measure as described (Walk and Hock, 1977).

The incorporation of ^{14}C -phosphoethanolamine (54 mCi/mmol) into ^{14}C -CDP-ethanolamine was measured within 60 min in an ECT-catalyzed reaction using 200 μg of the protein preparation, 30 μM ^{14}C -phosphoethanolamine (54 mCi/mmol) in the enzyme assay as described above, and linear incorporation was found within the first 30 min by the enzyme.

In tests of the effects of different divalent cations on enzyme activity, the ECT enzyme assays were performed as described above, except 200 μg protein, 30 μM ^{14}C -phosphoethanolamine (54 mCi/mmol), and 10 mM salt (MgCl_2 , CaCl_2 , MnCl_2 , CuSO_4 , ZnSO_4 or FeSO_4) were used in the reaction mixture of 100 μL volume. The reaction mixture without any divalent cation, but in the presence of 2.5 mM EDTA, was used as a control. In the test for effects of pH on the ECT activity, the reaction buffers were 20 mM Tris-acetate at pH 5, 5.25, 5.5, 5.75, 6 and 6.25; 20 mM Tris-maleate at pH 6.5, 6.75, 7.0, 7.25, 7.5 and 7.75; and 20 mM Tris-chloride at pH 7.0, 7.25, 7.5, 7.75, 8.0, 8.25, 8.5 and 9.0, with 10 mM MgCl_2 , 2 mM CTP, 30 μM ^{14}C -phosphoethanolamine (54 mCi/mmol) and 200 μg protein in 100 μL reaction volume. The mixture was incubated at 30°C for 30 min and stopped by boiling for 5 min. The products were separated by thin-layer chromatography as described above and the formation of radiolabeled CDP-ethanolamine was quantified by liquid scintillation spectrometry after being recollected from the TLC plates.

Measurement of ECT activity as a response to substrates was performed by measuring the activity at fixed concentrations of one substrate while varying the other substrate. The initial velocity of CDP-ethanolamine formation was measured in assays using 20 mM Tris-chloride at pH 7.5, 10 mM MgCl_2 , 30 μM ^{14}C -phosphoethanolamine

(54 mCi/mmol) and 200 µg protein in 100 µL reaction volume. When the CTP concentrations were fixed at 20, 50, 100 or 300 µM, the ¹⁴C-phosphoethanolamine was varied at 10, 30, 50 and 80 µM. When the ¹⁴C-phosphoethanolamine concentrations were fixed at 20, 30, 50 or 70 µM, the CTP were varied at 20, 30, 50 and 100 µM.

Results

a. Cloning of *ECT* cDNA

In order to obtain the correct oligonucleotides as primers to amplify the *ECT* cDNA from the *C. reinhardtii* cDNA library, we first used the ECT protein sequences of human and rat to search the EST database of *C. reinhardtii* in GenBank. This resulted in a total of 12 ESTs with high identities in the database (Appendix Table A1). These EST clones were assembled and fell into two separate contigs. The first contig of 5 ESTs contained a 5' untranslated region (UTR) along with a partial coding sequence, including the start codon and the first 175 amino acid residues of the ECT protein. The second contig of 7 ESTs covered the 3' UTR and a partial coding sequence corresponding to the C-terminal sequence (135 amino acid residues). Based on these contig sequences, we designed a number of primers that spanned the complete coding region of *ECT* cDNA for PCR amplification.

The cDNA in Lambda Zap II phage was transfected into *E. coli* to obtain the cDNA library in plasmids. To ensure complete coverage of all the cDNAs, more than 60,000 colonies of transformed *E. coli* were pooled for plasmid preparation. This is a greater than 5-fold representation of the total cDNAs estimated in the library. The pooled plasmids from the colonies were used as templates in PCR-based cloning of *ECT* cDNA.

To test the primers, we first tried all the primers in PCR amplifications using

genomic DNA as the template. The PCR products from these primers were sequenced and their sequences compared with the ESTs to confirm the authenticity of the DNA fragments with respect to the ECT protein sequence. Nested PCRs were performed using the pooled plasmid DNA as template and primers that spanned the complete coding sequence of *ECT* cDNA. Two forward primers and two reverse primers produced PCR products of 1.3 kb. The PCR products were extracted from the agarose gels and then subjected to sequencing. The deduced amino acid sequences were compared with those of ECT proteins in other organisms.

b. Sequence Analysis

The Nucleotide and Deduced Amino Acid Sequences of *C. reinhardtii* ECT

The nucleotide sequence of the cDNA was determined from the coding portions of both strands. The untranslated region was determined by sequence alignment using all the ESTs in the *C. reinhardtii* database, including 5 ESTs at the 5' and 7 ESTs at the 3' end. The complete cDNA sequence was checked by aligning the sequence with the *C. reinhardtii* nuclear genome database (http://www.biology.duke.edu/chlamy_genome/) and the sequence was found to match scaffold_125 at 17879-21839 bp. The cDNA contained a total of 2019 bp (Figure 2.1). It had a 1329 bp open reading frame (ORF) that starts at base 193 with an ATG start codon and ends at base 1521 followed by a stop codon TGA. The 5' UTR is 192 bp and the 3' UTR is 498 bp. This ATG is very likely the start codon for translation initiation, since the deduced amino acid sequence showed no other methionine residue before the motif HXGH, which is believed to be in the first catalytic domain. The amino acid residues after position 75 begin to align significantly with other ECTs (Figure 2.2). The first 75 amino acid residues appear to include a

subcellular targeting sequence, as predicted by ExPASy Proteomics tools from the ExPASy Molecular Biology Server.

The complete ORF encodes a protein of 443 amino acid residues with a calculated molecular mass of 49.3 kDa. This is similar to the molecular mass of other ECTs in rat (45.2 kDa), human (43.8 kDa) and yeast (36.9 kDa). Like human, rat and yeast ECTs, *C. reinhardtii* ECT has a large internal repetitive sequence. Both of the repeat sequences have HXGH motifs (in position 84-87 and 288-291). The HXGH motif is present in the most conserved N-terminal regions of proteins in the cytidylyltransferase superfamily, and is believed to be in the catalytic site.

A hydrophobicity profile indicates that the overall sequence of *C. reinhardtii* ECT is hydrophilic, but contains one clear hydrophobic region in the N-terminus capable of forming a transmembrane domain (residues 15-40) (Figure 2.3A). Analysis of the secondary structure with Chou-Fasman algorithms predicted a region (residues 20-50) that could form an amphipathic α -helix (Figure 2.3B). This corresponds well with the hydrophobicity profile. In addition, there are two other regions of hydrophobic residues (position 95-120 and 330-370) in the N- and C-terminal portions of the protein. However, they are broken by stretches of hydrophilic residues and are unlikely to form transmembrane domains.

A search for putative consensus motifs in the Prosite database produced a number of possible phosphorylation sites for protein kinase C (9 sites) and casein kinase II (8 sites). One possible tyrosine kinase phosphorylation site was indicated in the C-terminus of the protein (KVKGEEAYY at position 425-433). Two potential myristoylation sites were found at the N-terminus of ECT (GLGVSL at position 22-27, GTISGW at position

Figure 2.1 Nucleotide and deduced amino acid sequences of *C. reinhardtii* ECT cDNA. Numbers for nucleotides is shown on the left. The putative start codon and polyadenylation signal are indicated by underline. The asterisk denotes the stop codon. GenBank accession number for the nucleotide sequence is AY234844.

1 AGTGCGAACAGTTCTAACACCCACTCCGACATCAGTGTCTAACTTGCTTTTGTGGCAGC
61 GGGAAAGCACCTTAGATTGACACATCAAGCAGGCGATACTTTCTTCATAGTGAAGGGTT
121 CAGTCCGCGAGACAGTCCACGTTACGTTTCGAGTCCGGCGCCCCTGCGCTGAACTCAG
181 ATCGGCAGCCAAATGGTCTTACTCGATTCCGGTCAAGCAAATCCATTGCTGTGGACTTGC
M V L L D S V K Q N P L L W T C
241 GCTGCTGGAGTCGTCCGGCCTGGGCGTCAGCCTGCTGTCATGGAAAGCTGCCAAGGCAGCG
A A G V V G L G V S L L S W K A A K A A
301 GAGCTGTATGTTCCGATTTCAGTACCAATACCGGCCGGGGACCATCAGCGGGTGGCTTGGC
E L Y V P I Q Y Q Y R P G T I S G W L A
361 AACGCTCTAGCCAACCACTCCAAGAGCCGGCGAAAGCGCCGCCCGTCCGCGTGTACCTT
N A L A N H S K S R R K R R P V R V Y L
421 GACGGCTGCTTCGACATGATGCACTACGGCCACGCGAATGCACTACGCCAGGCTAAGGGC
D G C F D M M H Y G H A N A L R Q A K A
481 GTGGGCGATGAGCTGGTGGTGGGGCTGATCAACGACGCGGAGATTATGCGCTGCAAGGGC
V G D E L V V G L I N D A E I M R C K G
541 CCGCCGTCATGAACGAGGAGGAGCGGCACACGCTGGTGGAGGCTGTCAAGTGGGTGGC
P P V M N E E E R H T L V E A V K W V D
601 GAGATCCTCACTGGCGTTCCTTACGATCTGAACCCGGAATTTGTGAACGAGCTGTTCACC
E I L T G V P Y D L N P E F V N E L F T
661 AAGCACCGGATAGATTACATCATCCACGGTGACACCCCTGCTTGCTGCCGGATGGCTCG
K H R I D Y I I H G D D P C L L P D G S
721 GACGCGTACGCACACGCGAAGAAGCTGGGGCGCTTCAAGATGGTCAAGCGGACGGAGGGC
D A Y A H A K K L G R F K M V K R T E G
781 GTCAGCACCCTGACATCGTGGGCCGATGCTCACCTGCAGCCGCGTCAACCACTTCATC
V S T T D I V G R M L T C S R V N H F I
841 AACGCAGATGAGCCGACCCGCTGGCCAAGTCGTTTCAGCATGGGCACGCCGCGGAGGAG
N A D E P H P L A K S F S M G T P R E E
901 TCCAACGCTGAGGCCTCCACCAGCGACGCCTCCACGCGCACCACGCTGTCCAAGTTCCTG
S N A E A S T S D A S T R T T L S K F L
961 CCCACGACCGCGCCTGGTGCAGTTTCCAACGCGCGCTGGCACCGGAGGGGCGCGC
P T S R R L V Q F S N G R V A P E G A R
1021 ATCGTGTATATCGACGGCGCCTTCGACTGCTTTACCCTGGGCACGTCAAGATCCTGCAG
I V Y I D G A F D C F H P G H V K I L Q
1081 GCCGCAAGGCCAGGGTGACTTCTGCTGGTGGGGCTGCACACGGACGAGGACGTGCAG
A A K A Q G D F L L V G L H T D E D V Q
1141 GCGCGCCGCGGCCGACCTGCCATCATGAACCTGCACGAGCGCAGCCTGTCGGTGTGCT
A R R G P H L P I M N L H E R S L S V L
1201 TCCTGCAAGTATGTGGACGAGGTGGTGTATCGGCAGCCCGTGCCTAATCACGGAGGACCTG
S C K Y V D E V V I G S P C V I T E D L
1261 ATGACGACCTTCAACATCAGCGTGGTGGTGCAGCGCTCCATGTTCGGAGACCAGTATGCTG
M T T F N I S V V V R G S M S E T S M L
1321 GGGCCAGTGGAGGAGGAGCGGTACGAGGTGCTCGCCGATGGGCTGTTACGGAGCTG
G P V E E E R Y E V P R R M G L F T E L
1381 CCCAGCCCCAGCGACGTGTCGGCGCGCAACATTATCCACCGCATCGTGGACAAGCGCGCG
P S P S D V S A R N I I H R I V D K R A
1441 GCTTTTCGAGGCGCGCAACGCCAAAAGGTCAAGGGCGAGGAGCCTACTACCCGGGGCC
A F E A R N A K K V K G E E A Y Y T G A
1501 AAGCAGTACGTGCAGGAGTTGTGAACGGCGCCAGCTTGGTTACCGCGGTTACAGGTTGAA
K Q Y V Q E L *
1561 GGCCTGCCTGGTGCACGTGTGAGGGTTACTGATGCTCGAATAGTGCCTTTGTGTGTAC
1621 GTTGTATCGTATGTGGCTATGGCGTCTGAGGCGGTTTGGTACGGCCGTCGGAGGAAAGG
1681 CGTGAGGCACAATGCGTTGGCGATGTTTTGATGTGGGCGGGAGGTTTGCGGGATGCTTGC
1741 TGTGCGATTGTGCGGACTGTGGACCAGGGGGCTTCTAGCTGACGAGTATATGCTGCTTT
1801 CAACGAAATGCTGTGGGGCGGATAGCCGCCCGCTAGTGACGTGGACAAGCTCAGGAGC
1861 ATGGCTGCAATGTGCCGAGTAGGCTCTGGTATTGCGTTGACGTGTATTGGACGGACAGAC
1921 GAATGGCGTACCGTACCGTTTAGACGACACAAACGGATTTACGGACACTGTATGTGGCTC
1981 ATTTTCATCACTCTGTAAGATGATAATGCACCAAAAAA

```

cECT 1  MVL LDSVKQNPLLWTC AAGV VGLGV SLLSWKAAKAAELVPIQYQYRPGTISGWLANALA
hECT 1  -----MIRNNGRGAAGG
rECT 1  -----MIRNNGHGAGGA
yECT 0  -----

cECT 61 N HSKSRRKR RRPVRVYLDGCFDMMHYGHANALRQAKAVG----DELVVGLINDAEIMRCKG
hECT 12 AEQPGPGRRRAVRVWCDGCDYDMVHYGHSNQLRQARAMG----DYLIIVGVHTDEEIAKHKG
rECT 12 AGLKGGPGQRTVRVWCDGCDYDMVHYGHSNQLRQARAMG----DYLIIVGVHTDEEIAKHKG
yECT 1  ----MTVNLD PDKVWIDGCFDFTHHG HAGAILQARRTVSKENGKLCFVGHTDEDIQHNKG
                * * * *

cECT 117 P PVMNEEERHTLVEAVK WVEIL TGV P YDLNPEFVNE LFTKHRIDYIIHGDDPCLLPDGS
hECT 68 P P VFTQEERYKMVQA I K W D E V V P A A P Y V T ----TLETLDKYNCDFCVHGNDITLTV DGR
rECT 68 P P VFTQEERYKMVQA I K W D E V V P A A P Y V T ----TLETLDKHNCDFCVHGNDITLTV DGR
yECT 57 T P V M N S S E R Y E H T R S N R W C S E V V E A A P Y V T D P ----N W M D K Y Q C Q Y V V H G D D I T I D A N G E

cECT 177 D A Y A H A K K L G R F K M V K R T E G V S T T D I V G R M L T C S R V N H F I N A D E P H P L A K S F S M G T P R E E
hECT 124 D T Y E E V K Q A G R Y R E C K R T Q G V S T T D L V G R M L L V T K A H H S S Q E M S S E Y R E Y A D S F G -----
rECT 124 D T Y E E V K Q A G R Y R E C K R T Q G V S T T D L V G R M L L V T K A H H S S Q E M S S E Y R E Y A D S F G K P P H P
yECT 113 D C Y K L V K E M G R F K V V K R T Y G V S T T E I I H R I L T K K S L P P T H P D Y Y P T T Q E L S -----

cECT 237 S N -----A E A S T S D A S T R T T L S K F L P T S R R L V Q F S N G R V A P E G A R I V Y I D G A F D C F
hECT 179 -----K C P G G R N P W T G V S Q F L Q T S Q K I I Q F A S G K E P Q P G E T V I Y V A G A F D L F
rECT 184 T P A G D T L S S E V S S Q C P G G Q S P W T G V S Q F L Q T S Q K I I Q F A S G K E P Q P G E T V I Y V A G A F D L F
yECT 164 -----F Y S V A Q D A V S K H C Y V F Q R D L D N V L V N G G Y K F D A E D C V Y V D G D F D L F

cECT 288 H P G H V K I L Q A A K --A Q G D F L L V G L H T D E D V Q A R R G P H L P I M N L H E R S L S V L S C K Y V D E V V
hECT 226 H I G H V D F L E K V H R L A E R P Y I I A G L H F D Q E V N H Y K G K N Y P I M N L H E R T L S V L A C R Y V S E V V
rECT 244 H I G H V D F L Q E V H K L A K R P Y V I A G L H F D Q E V N R Y K G K N Y P I M N L H E R T L S V L A C R Y V S E V V
yECT 210 H M G D I D Q L R K L K M D L H P D K K L I V G I T T S D Y S S -----T I M T M K E R V L I V L S C K Y V D A V I
                * * * *

cECT 346 I G S P C V I T E D L M T T F N I S V V V R G S M S E T S M L G P V E E E R Y E V P R R M G L F T E L P S P S D V S A R
hECT 286 I G A P Y A V T A E L L S H F K V D L V C H G --K T E I I P D R D G S D P Y Q E P K R R G I F R Q I D S G S N L T T D
rECT 305 I G A P Y S V T A E L L N H F K V D L V C H G --K T E I V P D R D G S D P Y E E P K R R G I F C Q I D S G S D L T T D
yECT 264 I D A D A T S M S Q Y N -----C E K Y H I G T A V L T A A G K F S E Y L T K E

cECT 406 N I I H R I V D K R A A F E A R N A K K V K G E E A Y Y T G A K Q Y V Q E L ----- 443
hECT 344 L I V Q R I I T N R L E Y E A R N Q K K E A K E L A F L E A A R Q Q A A Q P L G E R D G D F 389
rECT 362 L I V Q R I I K N R L E Y E A R N Q K K E A K E L A F L E A L R Q Q E A Q P R G E T D --- 404
yECT 300 L I V K R V E S Q R E V Y I A R N Q K K G M S I ----- 323

```

Figure 2.2 Alignment of amino acid sequences of *C. reinhardtii* ECT and other ECTs in human, rat and yeast. The amino acid sequences of *C. reinhardtii* ECT (cECT, GenBank accession number AAO60076), human ECT (hECT; NP_002852), rat ECT (rECT; NP_446020) and yeast ECT (yECT, BAA09310) are compared. The conserved HXGH motifs are labeled with an asterisk, and the cytidylyltransferase family RTXGVSTT signature in the sequences is underlined. Residue numbers for amino acids are shown at the left. Gaps in alignments are indicated by dashes. Residues that are identical in three or more sequences are shaded in grey.

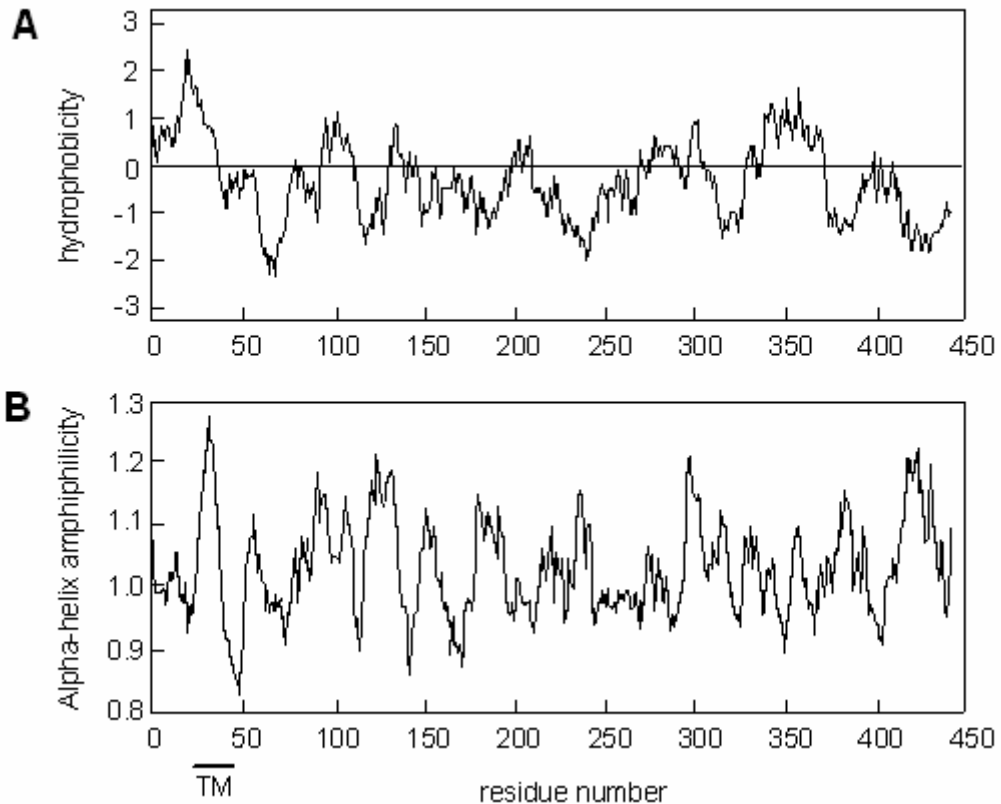

Figure 2.3 Hydropathy and α -helix amphiphilicity profiles of the predicted protein sequence of *C. reinhardtii* ECT. (A) Hydropathy profile. Hydrophobicity was analysed by the method of Kyte and Doolittle (Kyte and Doolittle, 1982). Positive values represent hydrophobicity. (B) α -helix amphiphilicity profile. The sequence was analysed for amphipathic α -helices using the algorithm of Chou and Fasman (Chou and Fasman, 1978). The predicted membrane-spanning domain is indicated on the bottom of the figure as TM.

49-54). A potential type-1 copper protein signature was indicated at position 282-296 (GAFDCFHPGHVKILQ).

Sequence Similarity to ECT of Other Organisms

The predicted *C. reinhardtii* ECT protein is 41% identical to human and rat ECTs, and 30% identical to yeast ECT (Table 2.1). This is greater than that of yeast ECT to human or rat ECT proteins but much lower than that of human to rat ECT protein (88%). *C. reinhardtii* ECT (443 residues) is somewhat longer than those of human (389 residues), rat (404 residues) and yeast (323 residues), which appears to result from an extended N-terminal region. The N-terminus has 75 amino acid residues that do not match the N-terminus of any other ECT. When these 75 residues are not included in the comparisons, identity of the *C. reinhardtii* ECT protein increases to 50% to human or rat ECT, and 40% to yeast (Table 2.1).

While the similarity between *C. reinhardtii*, human, rat and yeast ECTs is present across the entire sequence of the proteins, there are greater similarities when the N- and C-terminal regions (residues 71-207, residues 259-426) are compared than in the middle (residues 208-278). When the N- and C-terminal halves within the same ECT protein were aligned for each organism, an identity of 33% was found in *C. reinhardtii*, 30% in human and 32% in rat, but only 25% in yeast (Figure 2.4, Table 2.1). These differences are clearly seen in the phylogram representation (Figure 2.5). The C-terminal half of yeast ECT is more similar to those of human and rat ECT than to *C. reinhardtii*, while the N-terminal half of the yeast protein is more distantly related to the N-terminal parts of the other three. Both halves of the internal repeat sequence of ECT in *C. reinhardtii*, human and rat contain the HXGH motif. However, the C-terminal half of yeast ECT has an

Table 2.1 Identity (%) and similarity (% in parentheses) between CTP: phosphoethanolamine cytidyltransferases from *C. reinhardtii*, *H. sapiens*, *R. norvegicus* and *S. cerevisiae*

	<i>Chlamydomonas</i>	Human	Rat	Yeast
<i>Chlamydomonas</i>	-	41	41	30
Human	(62)	-	88	34
Rat	(62)	(91)	-	32
Yeast	(45)	(49)	(47)	-
<i>C. reinhardtii</i> *	-	50	50	40
N- and C-terminal halves**	33	30	32	25

* Identity of *C. reinhardtii* CTP: phosphoethanolamine cytidyltransferase without the N-terminal 75 residues to those ECT proteins of other organisms.

** Identity between N- and C-terminal halves within each ECT protein in different organisms.

amino acid residue change in the HXGH motif, substituting an aspartate in place of histidine. In addition, the *C. reinhardtii* ECT has other conserved residues which are considered important for catalytic activity in the cytidylyltransferase family, such as the sequence RTXGVSTT (residues 93-100) and an aspartate residue two amino acid residues before the HXGH motif in the N-terminal half of the protein.

C. reinhardtii ECT does not resemble other cytidylyltransferases in that it has a small, amphiphilic α -helical region at its very N-terminus, which appears to be a subcellular targeting sequence. On the other hand, *C. reinhardtii* ECT contains 38% hydrophobic amino acids, which is comparable to that in other ECTs such as human (34%), rat (34%) and yeast (37%).

c. Location of the ECT in Cells

The cellular location of the ECT enzyme was determined by testing activities in various cellular fractions and comparing the results to marker enzyme distributions (Table 2.2). The results showed that the total and specific activity of ECT were well correlated to those of fumarase, which is a marker enzyme of the mitochondria, but not to those of Rubisco and EPT, which serve as marker enzymes for chloroplasts and endoplasmic reticulum, respectively. Endoplasmic reticulum and mitochondria have been shown to be the primary candidates for sites of ECT activity in animals and higher plants (van Hellemond et al., 1994; Wang and Moore, 1991; Tang and Moore, 1997). This result is consistent with our early prediction using the deduced amino acid sequence of the *ECT* cDNA, which shows that the ECT protein is targeted to mitochondria after translation and probably is modified.

```

cECT-N 51 TISGWLANALANHSKSRKRRPVRVYLDGCFDMMHYGHANALRQAKAVG----DELVVGL
cECT-C 254 KFLPTSRRLLVQFSNGRVAPEGARIVYIDGAFDCFHPGHVKILQAQAKQG--DFLLVGLHT
hECT-N 1 MIRNGRGAAGGAEQPGPGRRVAVRVWCDGCVDMVHYGHSNQLRQARAMG----DYLIVGV
hECT-C 195 ---QTSQKIIQFASGKEPQPGETVIYVAGAFDLFHI GHVDFLEKVVHRLAERPYYIAGLHF
rECT-N 1 MIRNGHGAGGAAGLKGPGGQRTVRVWCDGCVDMVHYGHSNQLRQARAMG----DYLIVGV
rECT-C 193 ---QTSQKIIQFASGKEPQPGETVIYVAGAFDLFHI GHVDFLQEVHKLAKRPYVIAGLHF
yECT-N 1 -----MTVNLDPKVWIDGCFDFTHHGAGAILQARRTVSKENGLFCGV
yECT-C 149 CYVFQRDLDNVLVNGGYKFAEDCVYVDGDFDLFHMGDIDQLRKLKMDLHPDKKLIVGIT

cECT-N 107 INDAEIMRCKGPPVMNEEERHTLVEAVKWVDEILTGVPYDLNPEFVNEFLTCKHRIDYIIH
cECT-C 312 DEDVQARRGPHLPIMNHLHERLSVLSCKYVDEVVIGSPCVI----TEDLMTTFNISVVVR
hECT-N 57 HTDEEIAKHKGPPVFTQEERYKMQAIKWDEVVPAAPYVT----TLETLDKYNCDFCVH
hECT-C 252 DQEVNHYKGKNYPIMNHLHERTLSVLACRYVSEVVIGAPYAV----TAELLSHFKVDLVCH
rECT-N 57 HTDEEIAKHKGPPVFTQEERYKMQAIKWDEVVPAAPYVT----TLETLDKHNCFDVCVH
rECT-C 250 DQEVNRYKGNYPIMNHLHERTLSVLACRYVSEVVIGAPYSV----TAELLNHFKVDLVCH
yECT-N 46 HTDEEIQHNKGTVMNSSERYEHTRS NRWCSEVVEAAPYVT----DPNWMDKYQCQYVVH
yECT-C 209 TSDYSST-----IMTMKERVLI VLSCKYVDAVIIDADATS----MSQYN-----

cECT-N 167 GDDPCLLPD---GSDAYAHAKKLGFRFKMVKRTEGVSTTDIVGRMLTCSRNVNHFINADEPH
cECT-C 368 GSMSETSM LGPVEEERYEVPRRMGLFTELPSPSDVSARNI IHRIVDKRAAF EARNAKVKK
hECT-N 113 GNDITLTVD---GRDTYEEVKQAGRYRECKRTQGVSTTDLVGRMLLVTKAHHSSQEMSSE
hECT-C 308 GKTEIIPDR--DGSDPYQEPKRRGIFRQIDSGSNLTTDLIVQRIITNRLEYEARNQKKEA
rECT-N 113 GNDITLTVD---GRDTYEEVKQAGRYRECKRTQGVSTTDLVGRMLLVTKAHHSSQEMSSE
rECT-C 306 GKTEIIPDR--DGSDPYEEPKRRGIFCQIDSGDLTTDLIVQRI IKNRLEYEARNQKKEA
yECT-N 102 GDDITIDAN---GEDCYKLVKEMGRFKVVKRTYGVSTTEI IHRILT KKS LPPTHPDYYP T
yECT-C 249 -----CEKYHIGTAVLTAAGKFSEYLTKE L I V KR VESQREVIARNQKKG M

```

Figure 2.4 Sequence alignment of the N-terminal and C-terminal halves of the internal repetitive sequence of ECTs in different organisms. *C. reinhardtii* ECT (cECT-N and cECT-C), human ECT (hECT-N and hECT-C) and yeast ECT (yECT-N and yECT-C). Residue numbers of amino acids are shown at the left. Residues identical in five or more sequences are shaded in grey. Residue numbers for amino acids are shown at the left. Gaps in alignments are indicated by dashes.

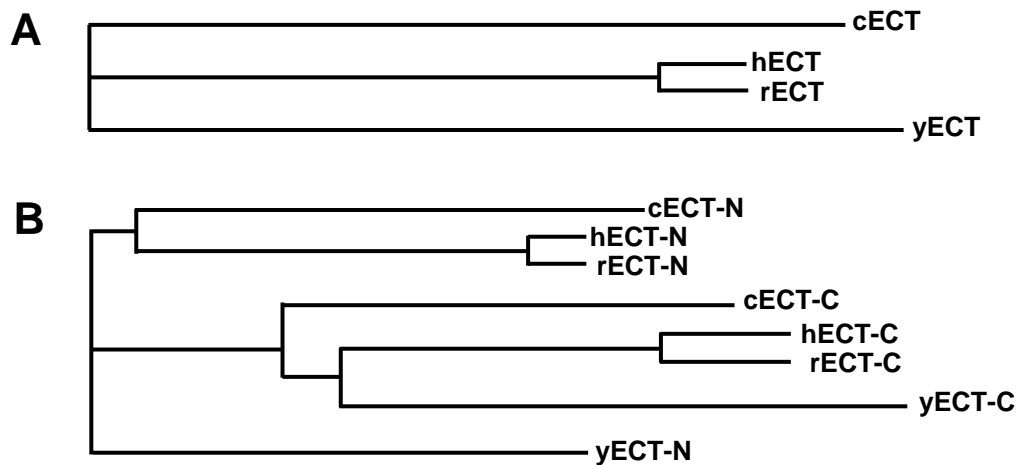

Figure 2.5 Phylogram of ECT proteins in different organisms. (A) The complete amino acid sequences of ECTs in *C. reinhardtii* (cECT), human (hECT), rat (rECT) and yeast (yECT) used for the phylogram were obtained from the sequence alignment shown in figure 2.2. (B) A comparison of the N- and C-terminal halves of ECTs from the four organisms used for the phylogram obtained from the sequence alignment shown in figure 2.4.

Table 2.2 Percentage of the total activity (%) and specific activity of marker and ECT enzymes in various cellular fractions of *C. reinhardtii*. EPT-ethanolaminephosphotransferase, ECT-CTP: phosphoethanolamine cytidyltransferase, supt-supernatant. Units for specific activity: fumarase, mmol/h/mg; Rubisco, nmol/h/mg; EPT, pmol/h/mg; ECT, pmol/h/mg. Units for total activity: fumarase, mmol/h; Rubisco, nmol/h; EPT, pmol/h; ECT, pmol/h. Unit of chlorophyll: mg/mL. The data here is from one representative experiment that was repeated twice with similar results.

Fraction	Chlorophyll	Fumarase		Rubisco		EPT		ECT	
		%	Specific	%	Specific	%	Specific	%	Specific
760g pellet	96.24	45.13	39.00	73.05	12.60	12.27	76.20	56.08	35.88
3,000g pellet	2.04	1.64	18.60	4.29	10.20	9.00	219.00	3.38	28.50
10,000g pellet	1.01	0.56	6.60	3.39	8.40	38.15	933.60	3.11	27.00
100,000g pellet	0.71	3.11	21.00	11.84	16.20	40.58	565.80	2.27	11.22
100,000g supt	0.00	49.56	21.60	7.43	0.60	0.00	0.00	35.16	11.40

d. Expression of ECT in *E. coli* Cells and ECT Activity Assay

In order to test the enzymatic activity of the *ECT* gene product, an in-frame fusion of *ECT* gene to *MAL*, which codes for maltose binding protein, was expressed in *E. coli* under control of a promoter inducible by IPTG. The expected overproduction of the fusion protein upon induction was observed (Figure 2.6A). Figure 2.6B shows the production of CDP-ethanolamine from phosphoethanolamine and CTP in a reaction catalyzed by both the cellular extract and purified fusion protein from the overexpressed cells. No CDP-ethanolamine was produced by an extract from cells that carry only the vector, pMAL-c2X (data not shown). In addition, we tested the enzyme activity of the fusion protein under different conditions (Figure 2.7) and found the activity to be dependent on the presence of CTP, phosphoethanolamine and Mg^{2+} .

e. Genomic Copy Number and Expression in *C. reinhardtii*

Southern blot analysis indicated that the *ECT* gene occurs as a single copy in the genome of wild type strain 137C of *C. reinhardtii* (Figure 2.8A). Northern blot analysis indicated that the abundance of mRNA from the *ECT* gene increased within 30 min of cell growth during reflagellation after deflagellation by pH shock (Figure 2.8B). The expression reached its highest level 90 min after the start of the reflagellation period, and then began to decrease. The mRNA abundance after 30 min of reflagellation was about 3-fold higher than in cells prior to deflagellation, whereas after 90 min it was less than 2-fold higher.

f. Enzyme Activity during the Cell Cycle

No significant change was detected in the expression of the *ECT* gene by measuring RNA from the cells during the cell cycle (Figure 2.9 bottom). However, a notable change

in

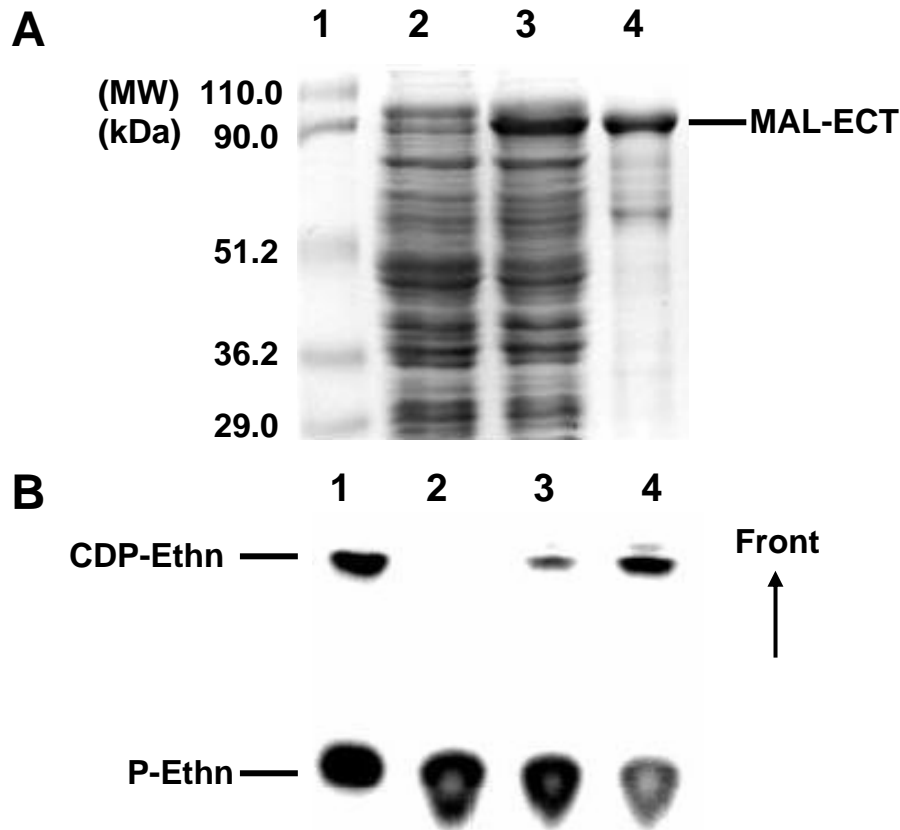

Figure 2.6 Expression of MAL-ECT fusion gene in *E.coli* and its ECT activity. (A) Cell extracts from induced or uninduced bacterial cultures and purified fusion protein were subjected to SDS-PAGE. Lane 1, protein markers; Lane 2, protein extract from uninduced *E. coli* cells; Lane 3, protein extract from induced *E. coli* cells; Lane 4, the purified MAL-ECT protein. (B) ECT enzymatic assays were performed using the same cell extracts and purified fusion protein as in (A). In the enzyme assay, the reaction mixture included 30 μg protein from *E.coli* cell extract or 15 μg of purified protein. The reaction products were separated by TLC as described. Lane 1, substrate standards; Lane 2, reaction with uninduced cell extract; Lane 3, reaction with induced cell extract; Lane 4, reaction with purified protein. Abbreviations: MAL-ECT, maltose binding protein and CTP: phosphoethanolamine cytidyltransferase fusion protein; P-Ethn, phosphoethanolamine; CDP-Ethn, CDP-ethanolamine. The activity assay of the expressed ECT in *E. coli* was repeated independently more than three times and the result in this figure was typical of all the replicate experiments that produced the same results.

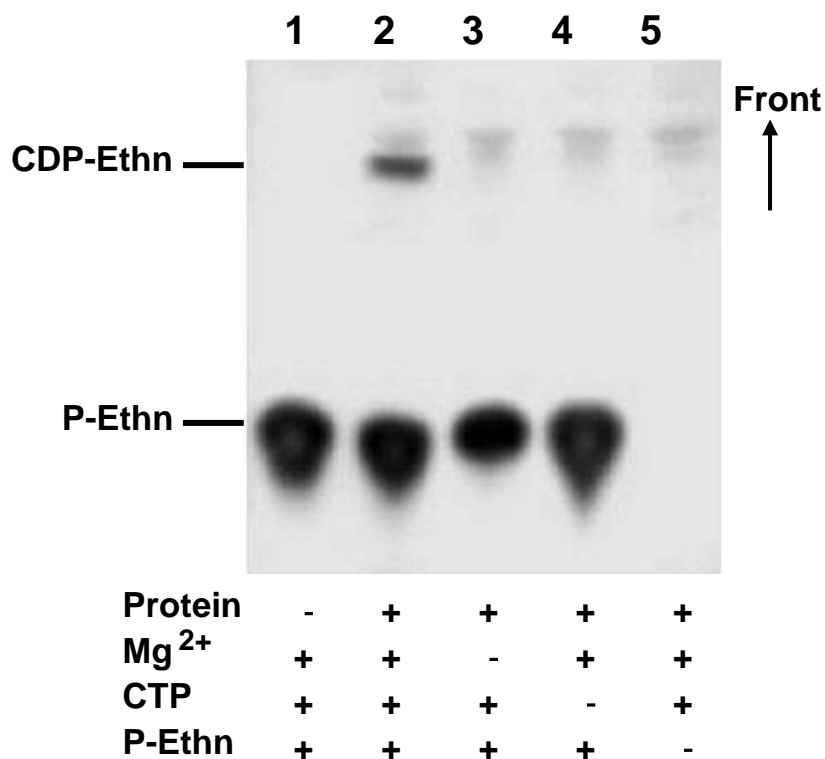

Figure 2.7 ECT activity of the MAL-ECT fusion protein expressed in *E.coli* under different conditions. The reaction mixture contained 15 μg of purified protein and was incubated at 30°C for 30 min as described. The reaction products were separated by TLC. Lane 1, no enzyme added; Lane 2, with enzyme; Lane 3, no Mg^{2+} added; Lane 4, no CTP added; Lane 5, no CDP-ethanolamine added. The data shown in this figure was from a single experiment that was repeated three times with the same results.

ECT enzymatic activity was observed in the cells during this same period (Figure 2.9 top). The ECT activity increased during the dark period, reaching the highest level right before the light was on, and then decreased during the light stage, reaching the lowest level just prior to the start of the next dark period.

g. Enzyme Activity at Varying pH, Divalent Cations and Substrate Concentrations

To further define the properties of the ECT enzyme, its activity was determined at different pH's and with divalent cations. The *C. reinhardtii* ECT had an optimal pH at about 7.5 (Figure 2.10), and among all the divalent cations at 10 mM in the reaction mixture the most effective was Mg^{2+} followed by Ca^{2+} , then Mn^{2+} . Cu^{2+} , Zn^{2+} and Fe^{2+} were less effective (Figure 2.11).

When the concentration of each substrate was varied at fixed concentrations of the other, two sets of straight lines were obtained in double reciprocal plots (Figure 2.12). The lines converge in a common point below the abscissa in each case, indicating a sequential type of reaction mechanism (Cleland, 1970). The apparent K_m values for P-Ethn and CTP were 59 μM and 43 μM respectively, as deduced from replots of the intercepts on the coordinate against the reciprocal of the concentration of the unvaried substrate (Florini and Vestling, 1957).

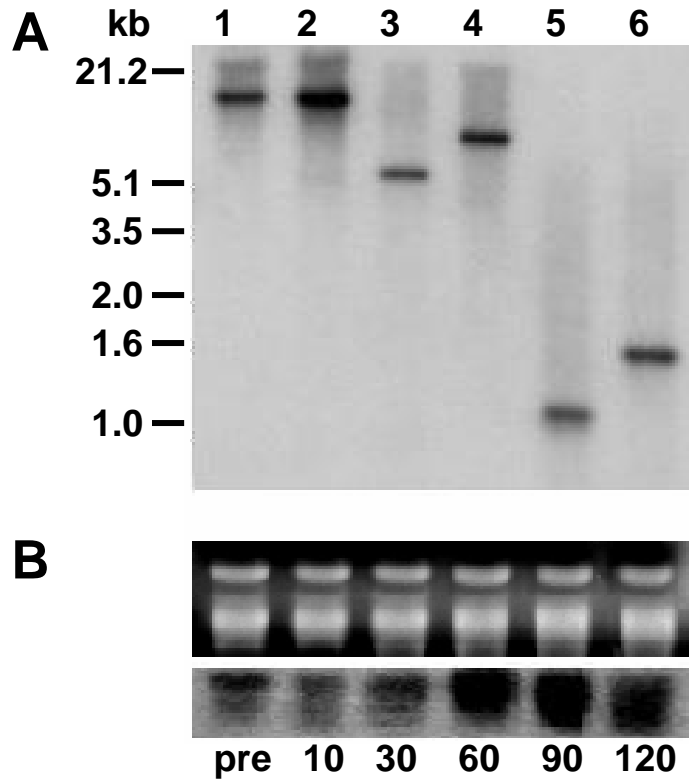

Figure 2.8 An analysis of the *C. reinhardtii* ECT gene. (A) Southern hybridization of genomic ECT gene. Genomic DNA was digested by *EcoRI* (lane 1), *EcoRV* (lane 2), *HindIII* (lane 3), *XmnI* (lane 4), *PvuII* (lane 5) and *PstI* (lane 6), separated on a 0.8% agarose gel, transferred to a Nytran membrane, and hybridized to a radiolabeled 0.4-kb probe from PCR of 3' coding region of ECT cDNA. (B) Northern hybridization of total RNA from *C. reinhardtii* cells during reflagellation. Total cellular RNA was prepared from cells prior to deflagellation (pre), and during the reflagellation after pH shock at 10, 30, 60, 90 and 120 min, subjected to electrophoresis through a 1% formaldehyde/agarose gel, transferred to a Nytran membrane and hybridized to the same probe as in the Southern blot.

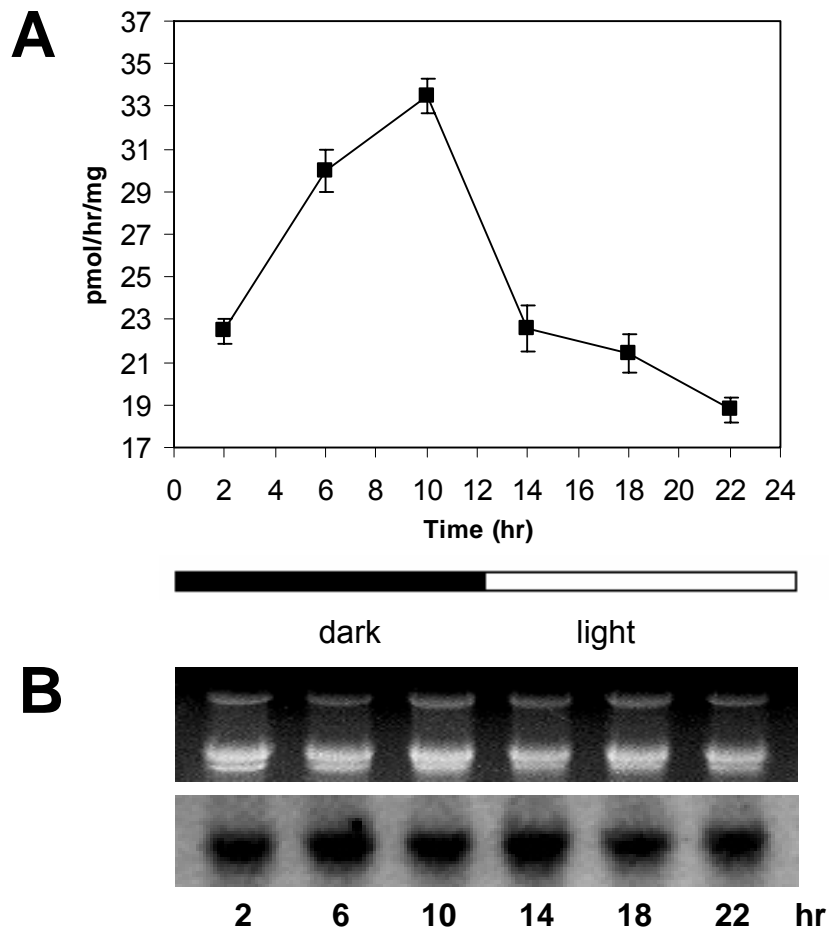

Figure 2.9 Activity of ECT during the cell cycle. (A) Total protein was prepared from cells taken at different times during the cell cycle and ECT activity was measured as described. Values for the enzyme activity are means \pm S.D. of three replicates of an experiment. (B) Total RNA was isolated from 137C cells taken at different times during the cell cycle. 30 μ g of total RNA were electrophoresed on a 1% agarose gel containing formaldehyde, transferred to a Nytran membrane, and hybridized to a probe prepared from 0.4 kb PCR fragment of cDNA.

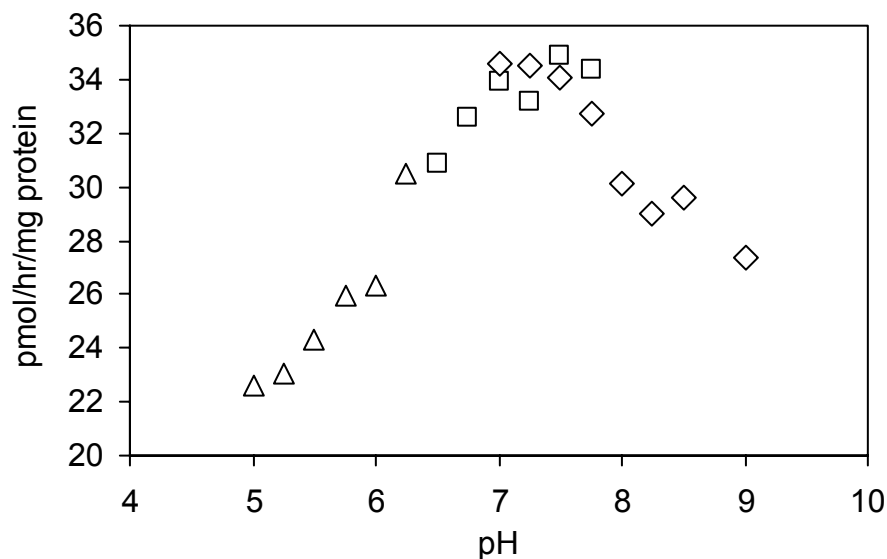

Figure 2.10 Effect of pH on the activity of ECT. The 100 μ L reaction volume contained the reaction buffer [20 mM Tris-Acetate (Δ), Tris-maleate (\square) or Tris-chloride (\diamond)], 10 mM Mg^{2+} , 2 mM CTP, 30 μ M ^{14}C -phosphoethanolamine and 100 μ g of protein from cell extracts of *C. reinhardtii* strain CC-406 cw15 (*mt*). The mixture was incubated at 30°C for 30 min. The reaction was stopped by boiling for 5 min. The products were separated by thin-layer chromatography (TLC) on a Silica Gel 60 plate (E. Merck, Darmstadt, Germany) with 96% ethanol: 0.5% NaCl: 25% NH_4OH (50:50:5 by volume) as the developing solvent. The CDP-ethanolamine spot was scraped into a scintillation vial and radioactivity was measured by scintillation counter.

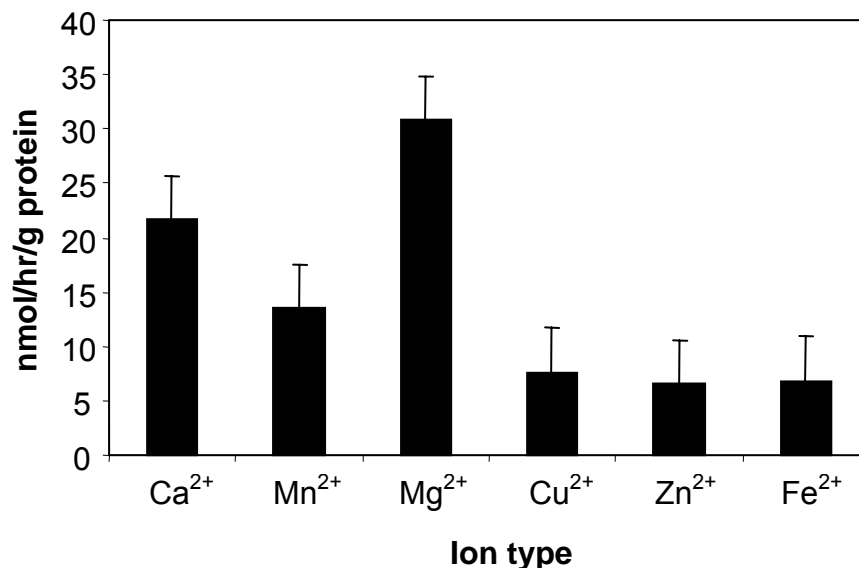

Figure 2.11 Effects of different cations on ECT activity. 100 μ L reaction volume contained 20 mM Tris-HCl (pH 7.5), 10 mM divalent cation (Mg^{2+} , Mn^{2+} , Ca^{2+} , Cu^{2+} , Zn^{2+} or Fe^{2+}), 2 mM CTP, 30 μ M ^{14}C -phosphoethanolamine and 100 μ g of protein from cell extract of *C. reinhardtii* strain CC-406 cw15 (*mt*). The reaction with 2.5 mM EDTA was used as control. The mixture was incubated at 30°C for 30 min. The reaction was stopped by boiling for 5 min. The products were separated by thin-layer chromatography (TLC) on a Silica Gel 60 plate (E. Merck, Darmstadt, Germany) with 96% ethanol: 0.5% NaCl: 25% NH_4OH (50:50:5 by volume) as developing solvent. The CDP-ethanolamine spot was scraped into a scintillation vial and radioactivity was measured with scintillation counter.

Discussion

The ECT cDNAs of three species, yeast, human and rat have been cloned (Min-Seok et al., 1996; Nakashima et al., 1997; Bladergroen et al., 1999). We report here the first cloning and characterization of cDNA coding for ECT from a photosynthetic organism, *C. reinhardtii*. The deduced polypeptide encoded by the cDNA consists of 443 amino acids with a molecular mass of approximate 49.3 kDa. The predicted amino acid sequence of the ECT protein shows a high degree of similarity to that of human and rat, however, the N-terminal region of the ECT from *C. reinhardtii* is longer than the ECT of the other three species.

The unique N-terminal region of about 75 amino acid residues appears to be a targeting sequence to mitochondria, as indicated by several prediction programs from the ExPASy Molecular Biology Server. It has been shown that the majority of ECT occurs in the mitochondria of castor bean endosperm (*Ricinus communis* L.), where it is associated with the outer membrane. The remainder of the enzyme activity was found in the endoplasmic reticulum of that organism (Wang and Moore, 1991; Tang and Moore, 1997). In our study, we tested cellular fractions from *C. reinhardtii*, and the results showed that the total activity of ECT was in the fraction that had the highest total activity of fumarase, but not in fractions that had the highest total activity of Rubisco and EPT, which serve as marker enzymes for chloroplasts and ER, respectively. The other fractions with the highest total activity of Rubisco and EPT representing chloroplasts and the endoplasmic reticulum also gave some ECT activity, but might be accounted for by mitochondrial membrane contamination. This does not, however, rule out the possibility that some ECT may be in the cytoplasm rather than the mitochondria, but the amount

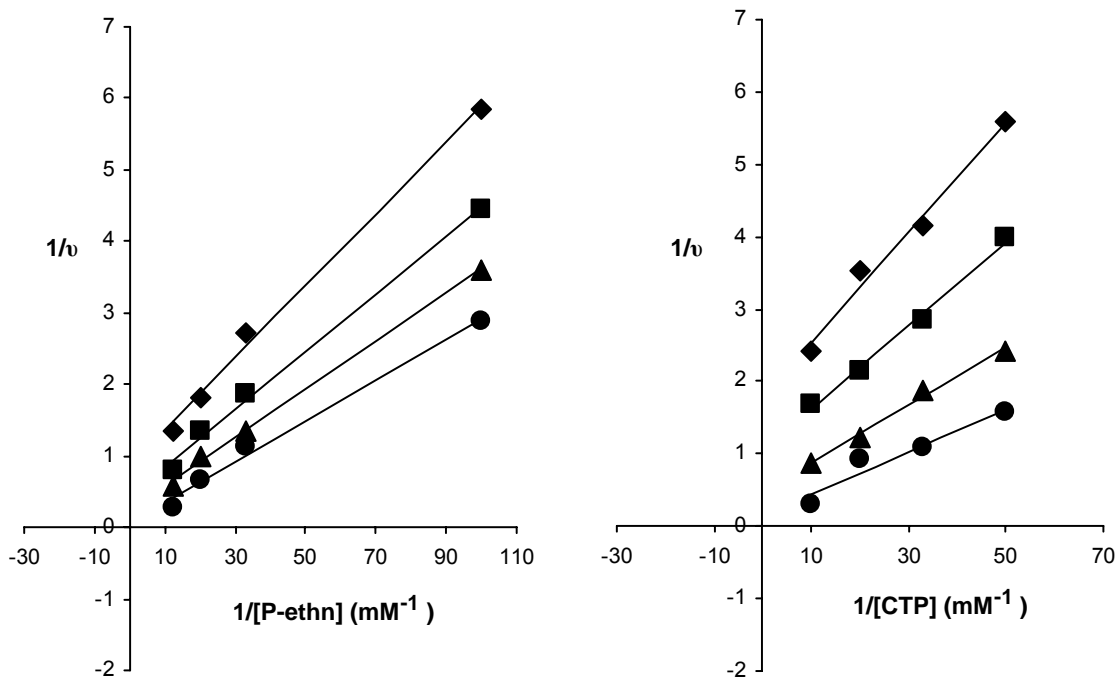

Figure 2.12 Lineweaver-Burk plot of fixed substrate concentration at various concentration of other substrates. On the left, the CTP concentrations were fixed and the phosphoethanolamine (P-ethn) concentrations were varied. The concentrations of CTP were 20 (◆), 50 (■), 100 (▲) and 300 (●) μM . On the right, P-ethn concentrations were fixed and the CTP concentrations were varied. The concentrations of ^{14}C -phosphoethanolamine were 20 (◆), 30 (■), 50 (▲) and 80 (●) μM . Initial velocity (v) is expressed as picomoles of CDP-ethanolmaine per min per mg protein (pmol/min/mg). The apparent K_m for P-Ethn is 0.059 (59 μM) and the apparent K_m for CTP is 0.043 (43 μM). The incorporation of ^{14}C -phosphoethanolamine into CDP-ethanolamine was found linear for 30 min at 30°C and the rate of reaction catalyzed by the enzyme was calculated as initial velocity as described in methods.

would be low. Therefore, the ECT of *C. reinhardtii* is primarily, if not exclusively, a mitochondrial protein, as it is in castor bean, a higher plant (Wang and Moore, 1991). By contrast, the ECT is primarily associated with rough endoplasmic reticulum or the cytosol in mammalian cells (van Hellemond et al., 1994; Vermeulen et al., 1993). Thus, the subcellular localization of ECT enzyme appears different between mammals and photosynthetic organisms. This difference in compartmentalization suggests the possibility that the regulatory mechanism may also differ between plants and mammals. It has been suggested for mammalian cells that ECT might reversibly interact with membranes of the endoplasmic reticulum, which could bring the enzyme into close proximity to the third enzyme in the CDP-ethanolamine pathway, ethanolaminephosphotransferase, an established integral microsomal protein that catalyzes the final step in the CDP-ethanolamine pathway (Vance and Vance, 1988). A mitochondrial location in photosynthetic organisms seems to contradict this mechanism of ECT regulation in the CDP-ethanolamine pathway proposed for mammalian cells. The origins and significance of these differences remain obscure at this time. Interestingly, the ethanolaminephosphotransferase appears to be microsomal in *C. reinhardtii* (Moore et al., 2001).

To compare the *C. reinhardtii* ECT to an *Arabidopsis thaliana* ECT protein with respect to the subcellular localization, a putative ECT protein from *Arabidopsis* database was retrieved and used to predict targeting sequences (GenBank accession number NP_181401). The ECT protein deduced from a putative *Arabidopsis* ECT gene had a significantly high homology to the *C. reinhardtii* ECT polypeptide (56% identity and 72% similarity). The N-terminal parts of the two protein sequences showed no similarity

(*Arabidopsis* residues 1-50, *C. reinhardtii* residues 1-67). Using the prediction programs in an effort to determine the subcellular localization of the *Arabidopsis* ECT protein, no clear targeting sequence to mitochondria, chloroplasts or endoplasmic reticulum was found (PSORT II Prediction program, iPSORT Prediction program and TargetP Prediction program in ExPASy, Proteomics tools from ExPASy Molecular Biology Server at <http://us.expasy.org/>) (Horton and Nakai, 1997; Bannai et al., 2002; Emanuelsson et al., 2000). However, an α -helix and a transmembrane domain were predicted in the N-terminal part of the sequence (position 1-30). The hydropathy profile of the *Arabidopsis* ECT protein indicated that it is predominantly a hydrophilic polypeptide. Therefore, the authentic subcellular location of *Arabidopsis* ECT protein is unclear although it appears more likely to be a cytoplasmic enzyme rather than being contained in any cellular organelle. The subcellular localization of *C. reinhardtii* ECT may be different from that of the *Arabidopsis* enzyme. Further investigation is needed to elucidate the significance of these different locations of this enzyme in *C. reinhardtii* and *Arabidopsis*, as well as in other organisms.

C. reinhardtii ECT is similar to the enzyme from yeast, rat and human, and apparently also *Arabidopsis*, in that it has a large repetitive sequence in its N- and C-terminal halves. It is likely that the two halves were generated through a gene duplication event. The advantage and functional role of this repetition are not clear as it is found only in ECT proteins and has not been observed in other cytidylyltransferases or glycerol-3-phosphate cytidylyltransferase (GCT) from *Bacillus subtilis* (Bork et al., 1995).

Based on the high degree of similarities between the N-terminal regions of human

and rat ECTs, as well as some well-conserved regions in the N-termini of other members of the cytidylyltransferase superfamily, including rat and yeast CCT proteins and GCT in *Bacillus subtilis*, it has been proposed that the N-terminus contains the catalytic domain of these cytidylyltransferases (Bork et al., 1995). This is supported by the fact that the catalytic activity of a truncated form of rat CCT, comprised of residues 1-236, was very similar to that of wild-type CCT (Wang and Kent, 1995). Since both repetitive sequences in ECT contain the HXGH motif that is present in the most conserved region of the N-terminus of the members in the cytidylyltransferase family and class I aminoacyl-tRNA synthetases (Delarue and Moras, 1993), and this motif is considered to be in the active site of these enzymes (Park et al., 1997; Veitch and Cornell, 1996), *C. reinhardtii* ECT might contain two catalytic domains like the ECTs of human, rat and yeast. It has been found that purified rat liver ECT has two *K_m* values for the binding of phosphoethanolamine, suggesting the existence of two binding sites for this substrate (Vermeulen et al., 1994). Further structural and functional analyses of the ECT are needed to clarify this assumption.

The ECT of *C. reinhardtii* has an Asp residue located at position 81, two residues ahead of the HXGH motif. An aspartate in this position is absolutely conserved in all cytidylyltransferase sequences. In addition, there is also an Asp residue (residue 285) located two residues ahead of the second HXGH motif in the second half of the repeat. These Asp residues may be in the active sites of ECT. Moreover, there is a RTXGVSTT in the ECT sequence (residues 282-296), which is considered a signature sequence for the cytidylyltransferase family (Park et al., 1997). Therefore, *C. reinhardtii* ECT appears to be a real member of this family.

There are a number of protein kinase C and casein kinase II phosphorylation sites throughout the entire sequence of the *C. reinhardtii* ECT based on the Prosite database search. There is also one site at the very C-terminus which was predicted as a site for tyrosine kinase (residues 425-433). By contrast, only two potential phosphorylation sites have been identified in rat ECT, one for protein kinase C and the other for casein kinase II (Bladergroen et al., 1999). The presence of numerous possible phosphorylation sites for different protein kinases in the *C. reinhardtii* ECT sequence raises the possibility that phosphorylation/dephosphorylation may be involved in the regulation of the enzyme activity *in vivo*, and this in turn suggests that the regulatory mechanism of *C. reinhardtii* ECT might be different from that of rat. However, there are no phosphorylation studies with any ECT, either *in vitro* or *in vivo*, and so whether or not these sites are phosphorylated *in vivo* remains to be determined. In addition to the phosphorylation sites, a potential type-1 copper blue protein signature in the ECT sequence (residues 282-296) was obtained from the Prosite database search. The 'type-1' copper proteins are small proteins which bind a single copper atom and they are characterized by an intense electronic absorption band near 600 nm (Garrett et al., 1984). The most well known members of this class of proteins are the plant chloroplastic plastocyanins, which exchange electrons with cytochrome C_6 , and the distantly related bacterial azurins, which exchange electrons with cytochrome C_{551} . To our knowledge, there is no previous report of such a signature sequence in the cytidylyltransferase family. It would be interesting if studies show this site does bind copper, and, if so, whether or not this plays a role in the regulation of enzyme activity.

A number of functions have been proposed for myristoylation of proteins, such as

stabilizing associations of the protein with cellular membranes, promoting specific protein-protein interactions, and influencing the appropriate folding of proteins. Two potential myristoylation sites were found at the N-terminus of the *C. reinhardtii* ECT sequence. However, myristoylation of this protein is unlikely since position 2 of the ECT protein is not a glycine, which is required for the covalent attachment of a myristoyl chain (Towler et al., 1988). It is possible that myristoylation could occur at an internal Gly exposed after proteolytic processing, such as in signal peptide cleavage. This type of processing has been observed in the myristoylation of virus VP4 capsid protein of the “foot and mouth” disease (Chow et al., 1987).

CCT, the key regulatory enzyme in the CDP-choline pathway for PC synthesis, has been studied extensively (Kent, 1995) and is similar to ECT. A number of mechanisms have been proposed for the regulation of CCT activity in mammalian cells, including phosphorylation/dephosphorylation and reversible translocation between the cytosol and membrane fraction (Kent, 1997). The cDNA for the *CCT* gene has been cloned in rat (Kalmar et al., 1990), human (Kalmar et al., 1994), and *Arabidopsis thaliana* (Choi et al., 1997) and the genes coding for CCT of yeast (Tsukagoshi et al., 1987) and *Plasmodium falciparum* (Yeo et al., 1995) have been sequenced. CCT contains only one catalytic domain at its N-terminus and is well conserved in different species (Craig et al., 1994). Based on the analogy between the CDP-choline and CDP-ethanolamine pathways, it has long been thought that ECT would be regulated in a manner similar to CCT. However, accumulated evidence indicates that the CDP-choline and CDP-ethanolamine pathways are independently regulated (Tijburg et al., 1989a; Bladergroen and van Golde, 1997). Further work on the differences between structure

and function of the ECT and CCT proteins is necessary for adequate comparisons of the regulation mechanisms. Since *C. reinhardtii* cells contain no PC in their membranes, the regulatory mechanism of ECT may be investigated independently of CCT; it also may be unique when compared with that of the same protein or CCT from other organisms.

There is very limited evidence that ECT activity or PE biosynthesis by the CDP-ethanolamine pathway is regulated at the transcription level. One investigation showed that the mRNA level of the rat *ECT* gene varied during development of rat liver (Bladergroen et al., 1999). In this study, we found that ECT might be regulated at the level of transcription during the reflagellation of *C. reinhardtii* cells, where a 3-4 fold increase in mRNA abundance was detected after 30 min of reflagellation of deflagellated cells. Whether or not this increase in mRNA level is correlated to an enhanced ECT activity is unknown, since an increase in ECT activity may not necessarily result from an enhanced *ECT* mRNA level. Such a disjunction between the mRNA level and ECT activity was found in our results from the measurements of the ECT activity and mRNA abundance during the cell cycle. A clear change in ECT activity was observed during the cell cycle while no notable change in *ECT* mRNA was detected, indicating a posttranslational regulation mechanism for ECT in the *C. reinhardtii* cells. The increase in ECT activity appears correlated to the cell division process as a preparation for cell division, which occurs immediately before the light period and may require enhanced *de novo* PE synthesis. Several reports have described the regulation of a *CCT* gene at the pre-translational level in mammalian cells (Tessner et al., 1991; Houweling et al., 1993; Hogan et al., 1996). However, in these studies the increase in *CCT* mRNA levels resulted from stabilization of pre-existing mRNA instead of an increase in gene

transcription. Although in one study an increase in mRNA of a *CCTα* gene from mouse embryo fibroblast cells was observed during the S phase of the cell cycle, it was not correlated with increased ECT activity and PC biosynthesis in the G₁ phase, but instead was in preparation for mitosis (Golfman et al., 2001). Positive associations between hepatic cell division and a high expression of *CCT* genes during the perinatal period have been reported (Sesca et al., 1996; Cui et al., 1997). Further studies on the correlation between *ECT* mRNA level and ECT activity may be needed to elucidate the mechanism of transcriptional or translational regulation of ECT in *C. reinhardtii*.

The optimal pH for ECT activity has been tested using highly purified preparation or postmicrosomal supernatant from rat isolated hepatocytes (Sundler, 1975) and the mitochondrial fraction from castor bean endosperm (Wang and Moore, 1991). It was shown that ECT in rat liver had two optima with a sharp optimum at pH 7.8 and one around pH 6 for a lower maximal activity. In contrast, the optimal pH for ECT in castor bean endosperm was 6.5. We found that *C. reinhardtii* ECT had maximal activity at about pH 7.5. Thus the pH requirement of ECT for maximal activity in vitro differs among organisms. However, the difference in optimal pH for ECT enzymes from various organisms may result from differences in the procedures for purification of ECT proteins. Consistent effects of different divalent cations on ECT activity in two previous reports showed that Mg²⁺ was the most efficient, while Mn²⁺ and Ca²⁺ gave about 50% and 10% of the Mg²⁺-stimulated activity and other divalent ions were ineffective (Sundler, 1975; Wang and Moore, 1991). In this study, Mg²⁺ also appeared most effective for *C. reinhardtii* ECT activity and Mn²⁺ gave about one-half the activity observed with Mg²⁺. However, Ca²⁺ seemed to be more effective than Mn²⁺ for ECT

providing about 70% of the Mg^{2+} -stimulated activity. The reason that Ca^{2+} worked better than Mn^{2+} on *C. reinhardtii* ECT is not clear. It is possible that Ca^{2+} may be involved in either the enzymatic catalysis or the regulation of *C. reinhardtii* ECT.

Detailed studies of the reaction mechanism of rat liver ECT were conducted by examining the inhibition pattern by the two products of the reaction (Sundler, 1975). Noncompetitive inhibition of phosphoethanolamine incorporation was observed with both products (CDP-ethanolamine and pyrophosphate), whereas competitive (CDP-ethanolamine) and noncompetitive (pyrophosphate) inhibition patterns were seen with CTP as the variable substrate. Based on this inhibition pattern, an ordered sequential reaction mechanism for rat liver ECT was proposed in which CTP is the first substrate to bind to the enzyme and CDP-ethanolamine the last product to be released (Sundler, 1975). From kinetic analysis in this investigation, in which *C. reinhardtii* ECT activity was measured using varying concentrations of each substrate at fixed concentrations of the other, a sequential type of reaction mechanism was supported. The *K_m* values obtained in this study for CTP (43 μ M) and phosphoethanolamine (59 μ M) were comparable to those observed with the rat liver ECT, 53 μ M for CTP and 65 μ M for phosphoethanolamine. Confirmation that the *C. reinhardtii* ECT-catalyzes an ordered sequential reaction requires more detailed study.

The molecular cloning of *C. reinhardtii* ECT cDNA in this study is the first step toward elucidation of the structure, function and regulation of ECT in this species. The primary structure from the cDNA for the ECT will guide us to further investigations on the regulatory mechanism for this enzyme and help us understand the physiological significance and regulation of the CDP-ethanolamine pathway in PE biosynthesis.

CHAPTER 3

STUDY OF ETHANOLAMINEPHOSPHOTRANSFERASE

Materials and Methods

Restriction endonucleases and other DNA modifying enzymes were from New England BioLabs (MA, USA). Primers were made by Integrated DNA Technologies (Coralville, Indiana, USA). [^{14}C]- CDP-choline was purchased from Amersham Corp (54 mCi/mmoL). CMP, CDP-ethanolamine and CDP-choline were from Sigma-Aldrich. All other chemicals were of reagent grade from miscellaneous sources.

a. cDNA Cloning and Sequencing

The cDNA library in plasmids was the same one as prepared for *ECT* cDNA cloning in the ECT study (Chapter 2), and it was used as template in PCR-based cloning of *EPT* cDNA.

The BLAST server (<http://www.ncbi.nlm.nih.gov/BLAST/>) was used to search the *C. reinhardtii* expressed sequence tag (EST) database (http://www.biology.duke.edu/chlamy_genome) with *Arabidopsis* and human AAPTase protein sequences (accession number AAC61768 and AAD25170, respectively) in order to find highly homologous EST clones. Two ESTs (accession numbers BF863705 and BF863706) from a single clone were obtained in the homology search. One EST corresponds to the 5' UTR and partial N-terminal coding sequence while the other is only part of the 3' UTR of the cDNA. Primers were designed based on the two EST sequences in order to clone the coding region of cDNA from the library described above. The primers that successfully produced the correct cDNA by nested PCR included the forward primers 5'-GCA GAC TGG TCC GTC CTA CT-3', 5'-GCG AGA GCT AGA ACT CCA GG -3' and reverse

primers 5'-CCG CAT TCG ACA ACA CAC CT-3', 5'-ATC ACC GCA CCA CCA ACA G-3'.

The PCR products spanning the complete *EPT* coding region were subjected to agarose gel electrophoresis and extracted from the gel with spin columns from a QIAquick gel extraction kit (QIAGEN, Valencia, CA). The purified DNA fragments were sequenced on both strands using Applied Biosystems BigDye terminators (Foster City, CA, USA). The degenerate primers for sequencing the cDNAs included the forward primer 5'-TGA TGC TGT CGC TGG TGC-3', 5'-GTC ACA AGG AGC TGG GCA-3', and reverse primers 5'- TGC CCA GCT CCT TGT GAC-3' and 5'-GCA CCA GCG ACA GCA TCA-3', together with the primers used for PCR.

b. Sequence Analysis

Nucleotide and deduced amino acid sequences were compared with sequences in the databases at the National Center for Biotechnology Information (NCBI) by using the BLAST program (<http://www.ncbi.nlm.nih.gov/BLAST/>) (Altschul et al., 1990). Sequence analysis and alignments were obtained by using the multiple sequence alignment programs from the European Bioinformatics Institute EMBL-EBI server (<http://www.ebi.ac.uk/clustalw/>). The Prosite database from the EBI server (<http://ca.expasy.org/prosite/>) was used to find putative consensus motifs for specific domains. The protein subcellular localization, membrane topology, and ER retention signals were predicted by the PSORT prediction program (<http://www.psort.org/>) (Horton and Nakai, 1997) and the SMART (Simple Modular Architecture Research Tool) program (<http://smart.embl-heidelberg.de/>) (Letunic et al., 2004). Genomic sequences and intron positions of the *C. reinhardtii* *EPT* gene were obtained by searching the *C.*

reinhardtii genomic database using the cDNA sequence (<http://genome.jgi-psf.org/chlre1/chlre1.home.html>).

c. Southern Blot of Genomic DNA

Genomic DNA from *C. reinhardtii* wild type strain 137C was isolated as described (Rochaix, 1978). Five µg of genomic DNA were digested with restriction endonucleases (New England BioLabs), resolved on an 0.8% agarose gel, transferred to a Nytran membrane (Schleicher and Schuell, Keene, New Hampshire), and hybridized with a radiolabeled probe derived from the coding sequence of the *C. reinhardtii* EPT cDNA by PCR. The DNA transfer, hybridization and washes were as previously described (Sambrook et al., 1989).

d. Expression of *C. reinhardtii* EPT cDNA in *S. cerevisiae*

Yeast Strains and Growth

Yeast strains KT1115 (*MAT α* , *leu2-3*, *leu2-112*, *ura3-52*) and RK-ec (*MAT α* , *cpt1*, *ept1*, *his3- Δ 1*, *leu2-3*, *leu2-112*, *ura2-52*) were obtained from Dr. R. Dewey (North Carolina State University, Raleigh, NC). Yeast was cultured in YPD (1% yeast extract, 2% peptone, 2% dextrose) or synthetic minimal medium supplemented with proper amino acids at 20 mg/L (Guthrie and Fink, 1991). Unless otherwise stated, all yeast operations were carried out according to standard procedures as previously described (Guthrie and Fink, 1991). Expression of *C. reinhardtii* EPT cDNA from the *ADHI* promoter of yeast expression vector pDB20 was carried out by culture of the transformed yeast strain in YP-Glucose medium (1% yeast extract, 2% peptone and 2% glucose).

Yeast Transformation

Primers with *Hind*III-adaptor sequences were designed to amplify the complete

coding sequence of *C. reinhardtii* EPT cDNA. After digestion with *Hind*III, the PCR product was ligated into the *Hind*III site of a yeast expression vector pDB20 under control of the strong constitutive *ADHI* promoter (Becker et al., 1991). PCR, restriction endonuclease digestion and sequencing were used to check for the correct orientation and sequence fidelity of the insert on the vector. This construct, named pDB-EPT, was used to transform the yeast strain RK-ec, which is deficient in both EPT and CPT, by methods previously described (Gietz et al., 1992). The empty vector pDB20 was also used to transform RK-ec as a negative control.

Screening of Transformed Yeast Strain with Colony Autoradiography

Positive transformants were selected on selective medium (synthetic minimal medium supplemented with histidine and leucine, but without uracil). After 2 days at 30°C, transformant colonies began to appear on the selective plates. Colonies were then transferred onto YP-Glucose medium for colony autoradiographic assays.

Colony autoradiography was used to screen for yeast colonies complemented in EPT activity as previously described (Hjelmstad and Bell, 1987). The transformed yeast colonies were transferred to Whatman No. 42 circle filter paper (90-mm diameter) and the filter paper with the transformed colonies was frozen at -80°C for 2 h. The colonies were then permeabilized by drying the filter paper discs in front of an electric fan for 30 min at room temperature. Each filter was placed colony-side up in a Petri dish containing 1.2 mL of a reaction solution that contained 50 mM MOPS-NaOH, pH 7.5, 20 mM MgCl₂, 1.5 mg/mL BSA, 1 mM DTT, 5 µM [¹⁴C]-CDP-choline (54 mCi/mmoL). The filter was incubated at 30°C for 1.5 h and then transferred to a new Petri dish containing 1 mL of 10% trichloroacetic acid to stop the reaction and fix the radiolabeled PC to the

filter paper. After incubation at 4°C for 30 min, the filter was washed six times on a Buchner funnel with 50 mL of cold (4°C) 2% trichloroacetic acid. After drying in air, the filter was sprayed with three light coats of fluorographic enhancer (EN³HANCE, New England Nuclear) and exposed to Kodak X-Omat AR film at -80°C for 5 days.

Confirmation of PC as the product of the enzyme in the colonies tested by autoradiography was achieved by thin layer chromatography (TLC). Briefly, radiolabeled PC was extracted by soaking the filter discs in 10 mL of chloroform/methanol (1:1) overnight at 4°C. The organic phase was recovered by centrifugation at 2000g for 10 min after addition of 5 mL of 1 N HCl. After drying, the sample was redissolved in 30 µL of chloroform and applied to Silica Gel 60 TLC plates (EM Science, Gibbstown, NJ). Development was performed with a solvent of chloroform/methanol/ammonium hydroxide (29.3%)/water (70:30:4:2, v/v).

e. Inhibition Assay of EPT by CDP-aminoalcohols and CMP

Preparation of Microsomal Membranes from Yeast and *C. reinhardtii* Cells

C. reinhardtii strain CC-406 cw15 (*mt*⁻) was grown on a rotary shaker into the late exponential phase in 500 mL Tris-minimal phosphate medium (Harris, 1989) under continuous lighting and at room temperature. Cells were harvested by centrifugation at 1000g for 10 min at 4°C, washed once with 100 mL of cold 20 mM Hepes-KOH, pH 7.2, and once with 25 mL of GME buffer (20% glycerol, 50 mM MOPS-NaOH, pH 7.5, 1 mM EDTA). The pellet was resuspended in 2 mL GME buffer, and cells disrupted by vortexing at high speed with 2 mL of glass beads (425-600 microns) for a total of 2 min with one minute each time and with one minute interval for the cells being held on ice for 1 min between vortexing periods. The resulting homogenate was centrifuged at 14,000g

for 15 min at 4°C to remove the unbroken cells and debris. The supernatant was adjusted to a final volume of 20 mL with GME buffer and centrifuged at 100,000g for 1.5 h at 4°C. This pellet was resuspended in a total of 0.5 mL GME buffer using a 15 mL Tenbroeck glass homogenizer (Pyrex, Corning Incorporated, NY). Aliquots of the suspension were stored at -80°C. All centrifugations were performed at 4°C, and the samples were kept on ice during all other steps of the procedure. The membrane protein concentration was measured by the Bradford method using BSA as the standard (Bradford, 1976).

Yeast colonies were inoculated into 200 mL of YP-Glucose, grown to an A_{600} of 1.5, and harvested by centrifugation at 1000g for 10 min. The harvested cells were washed by centrifugation once with 100 mL of distilled water and once with 25 mL of GME buffer. The final pellet was resuspended in 1 mL of GME buffer. The resuspended cells were disrupted by vortexing at high speed with 2 mL of glass beads (425-600 microns) for one minute periods for a total of 4 min, with the cells being held on ice for 1 min between vortexing periods. The microsomal membrane protein was pelleted, aliquoted, and stored as described for the *C. reinhardtii* microsomes.

EPT Enzyme Inhibition Studies by CDP-aminoalcohols and CMP

The *C. reinhardtii* EPT enzyme assay was conducted with 100 µg aliquots of microsomal membrane protein from either yeast or *C. reinhardtii* microsomal preparations. The microsomal membrane protein was incubated in an assay mixture containing 50 mM MOPS-NaOH, pH 7.5, 20 mM MgCl₂, 1 mM EDTA, and 25 µM [¹⁴C]-CDP-choline (54mCi/mmoL). Linear incorporation of radiolabeled substrate into PC over a 30 min period was observed with microsomal membranes prepared from the

yeast strains KT1115 and RK-ec::pDB-EPT, and *C. reinhardtii* strain CC-406 cw 15 (*mt*). Microsomal membranes isolated from yeast strain RK-ec and RK-ec:: pDB20 produced no detectable quantities of [¹⁴C]-PC (data not shown). In substrate competition studies, non-radiolabeled CDP-aminoalcohols or CMP were added to different reaction mixtures in a final reaction volume of 100 μL. After incubation at 30°C for 20 min, 1 mL of 0.1 N HCl and 2 mL of chloroform/methanol (2:1, v/v) were added to stop the reaction and extract radiolabeled PC. TLC was used to confirm the production of radiolabeled PC from the enzyme assays as described earlier. The radiolabeled PC produced from microsomal membrane assays was quantified using liquid scintillation spectrometry.

Results

a. Sequence Analysis of the *EPT* Gene

The cDNA of the *EPT* gene of *C. reinhardtii* contains a single open reading frame that encodes a 383 amino acid polypeptide (Figure 3.1). When this deduced amino acid sequence was used to search the protein database in GenBank, a number of highly homologous protein sequences were obtained. These included aminoalcohol-phosphotransferases from yeast, human, animals and plants. The identity and similarity in AAPT protein sequences between *C. reinhardtii*, yeast, human, mouse and plants are listed in Table 3.1. In comparison with yeast CPT1 and EPT1, *C. reinhardtii* EPT (cEPT) protein is 45% similar (25% identical) to the yeast EPT1 polypeptide and 42% similar (25% identical) to the yeast CPT1 protein at the predicted amino acid level. The identity and similarity of *C. reinhardtii* EPT to the proteins of other organisms is similar to those of yeast. Relatively high similarities in AAPT sequences were found among higher plant species, as well with human and mouse.

Figure 3.1 Nucleotide and deduced amino acid sequences of *C. reinhardtii* EPT cDNA. Residue numbers for nucleotides are shown at the left. The putative start codon is indicated by underline. The asterisk denotes the stop codon. GenBank accession number for *C. reinhardtii* EPT is AY375472.

1 GCACGAGGAGATAACTAGTATCCCCTCAAATACCAATACTTTGCTACCAGCTCGAGAACT
61 CCCGCTTTGAACTAAACTTTTGTTCGCCGTGCAGACTGGTCCGTCCTACTTTGCGATTAG
121 GGCAAAGTTTTGAATATCAATGGTTTTAAAAATACAATAAAGCGAGAGCTAGAACTCCAGG
181 CAGAAATGGTCAAGGTCTGTGCCTCGCGCCCTGGAGGGCTTGAAGAACTATGTATACA
M V K V L S P R A L E G L K N Y V Y
241 AGCCAGGCGGCTACACATGGCTGGACCACGCGCATACTCCCTTTTGGAACTGGTTGACTG
K P G G Y T W L D H A H T P F W N W L T
301 CCCAGCTGCCGATGTGGCTGGCGCCGAACCTCATCACGCTAGTGGGCCTCATAGTGACGT
A Q L P M W L A P N L I T L V G L I V T
361 TCATCGCGTATGGCACTATGTGGTACTATCTCCCGGAGTACACAGGTGAGGGCCCGCT
F I A Y G T M W Y Y L P E Y T G E G P R
421 GGCCCTACTTCTTCGCGGGCGTGTCCATTCTGGTTTACACCAACCTGGACTGCATCGACG
W P Y F F A G V S I L V Y T N L D C I D
481 GCAAGCAGGCGCGGCGCACCCGGCACCCAGCAGTCCCCTGGGGCAGCTGTTCCGACCACGGCT
G K Q A R R T G T S S P L G Q L F D H G
541 GCGACGCCGTGCGCTGCACGTGATGCTGTGCTGGTGCAGGCCTCGCTGGCGGAGCCGC
C D A V A L H V M L S L V Q A S L A E P
601 CGTCCGTGTTTCGCCAGCGTGGCGGCCATGTCCGGTGTATCTGCCCTGGTGGGTGAGCCACT
P S V F A S V A A M S V Y L P W W V S H
661 GGGAGGAGTACCACACGGGCGTGTCTATGTACGGCGACGGCAACTTCGGCATCCTGGAGG
W E E Y H T G V L M Y G D G N F G I L E
721 CCAACTACGTACTGGCGCTGGTCACCTTCATCACCGGCACCTTCGGGCCGGCCATGTGGG
A N Y V L A L V T F I T G T F G P A M W
781 ACACGCCCATGCGCTCCATCGTGCCTCGTGTTCCTGGGACACATCTGTGAAGCACGCGT
D T P M R S I V P V F P W D T S V K H A
841 TCATCGTGTTCGCCATGTGCATCGCGCTCATCCAGAACTACGGCCAGCTGTACCGCGTGT
F I V F A M C I A L I Q N Y G Q L Y R V
901 TCTCACGGCACTGGACCATGCTGCCTGAGGCGGAGCGCGGTCAACAAGGAGCTGGGCAACG
F S R H W T M L P E A E R G H K E L G N
961 CCTCCCGGCTGACGCACCTGGCCTCGGGCGCGGCTCATCTTCCTGGGGGCCGTGTACC
A S R L T H L A S G A A L I F L G A V Y
1021 TGGCCGACAACAAGCTGCAGCCGGGGCAGGCCAGGCTGGCGGGGCTGCTGTACGGGCTGG
L A D N K L Q P G Q A R L A G L L Y G L
1081 TGTACGCCATCGTGGCCACGCAGCTCATCATGGACCACATGTGCAAGGAGCCCTTCAGGT
V Y A I V A T Q L I M D H M C K E P F R
1141 CGCCGCTGCTGCCGCTGGCGGTGCTGACGGTGGCCGCCCAACAGCGTGTGCTGCAGCTGG
S P L L P L A V L T V A A A N S V L Q L
1201 TGGACGCGCGGGCCACGGCGGCCACGCTGGCGGGCGCCATGATTGTGTACTACCTGGTGT
V D A R A T A A T L A G A M I V Y Y L V
1261 ACGTCACGACCATTGTGGACCAGGTGTGTGCCTACCTGGGGATAAAGTGCCTCACCATCA
Y V T T I V D Q V C A Y L G I K C L T I
1321 CGCCCAAGCGCGCTGAGAGCGTGCAGGAGCGAGGGTGTGTGGGTGCTGCTCTAAGGGTT
T P K R A *
1381 GGTGGGGTGGGGGCGTGGAAAGCCTGTTGGTGGTGCGGTGATGGGGGGCTGGGGTGGACG
1441 TGTGCGAGGATCCGGTATGCCCGGGCGTGTATCGAAAACAAGGTGTGTTGTGCAATGCG
1501 GGCCTGCAAGATCTTTCCGATGAGAGCTCGTTTTATCTTCCAGGTGGGGCACTAGAGGTG
1561 ACTAGCAGGACGTGCGAATCAAAGCGAGAGCGCTGAAATGGCATGTGGCTCTCGTCTACC
1621 GTAGCAACAGTGATGGTGGCCCCATGAAGGTGGCTATACATAAAGGGTATGCGCAGGCCG
1681 TCAGCCCCTGTGCGCGAGAGAAACGAGTGCAGAAATGGAAGATCTCTAAGAGCACGTAGA
1741 GGCTCGGACCTTGTGGACTAAGGGAATACTGGTTGTGTTGCCATGGACCATGTGCCAGAA
1801 CGCAGTAAAGGGCAAACGGGTAGACGGCTCAAGTGGTGGGTTTCATGTGCGAACCTGTGAT
1861 AACGTGGCGATGGTTGTGTTGGGTTGTGACATATTGAAGGCGCCGTGCCGCGGAACCTTTG
1921 ACGGGGAAGGTGCTACGACACGGTTTTGGGCATCGGCCAACTAAAAAAA

Table 3.1 Identity (%) and similarity (% in parentheses) between aminoalcoholphosphotransferases in various organisms. cEPT- *Chlamydomonas reinhardtii* EPT, yEPT1- *Saccharomyces cerevisiae* EPT1, yCPT1- *Saccharomyces cerevisiae* CPT1, hCPT/EPT- *Homo sapiens* CPT/EPT, mCPT/EPT- *Mus musculus* CPT/EPT, AtAAPT1- *Arabidopsis thaliana* AAPT1, AtAAPT2- *Arabidopsis thaliana* AAPT2, GmAAPT1- *Glycine max* AAPT1), BrAAPT1- *Brassica rapa* AAPT1.

	cEPT	yEPT1	yCPT1	hCPT/EPT	mCPT/EPT	AtAAPT1	AtAAPT2	GmAAPT1	BrAAPT1
cEPT	-	25	25	28	29	27	29	27	25
yEPT1	(45)	-	56	24	24	31	30	32	30
yCPT1	(42)	(72)	-	25	25	32	30	30	32
hCPT/EPT	(46)	(42)	(43)	-	95	28	27	28	28
mCPT/EPT	(46)	(41)	(43)	(95)	-	27	26	27	27
AtAAPT1	(43)	(46)	(48)	(44)	(44)	-	87	80	97
AtAAPT2	(43)	(45)	(47)	(45)	(44)	(92)	-	77	87
GmAAPT1	(42)	(47)	(47)	(43)	(43)	(89)	(85)	-	80
BrAAPT1	(42)	(45)	(48)	(44)	(44)	(98)	(92)	(89)	-

An alignment of AAPT protein sequences from *C. reinhardtii*, mammals and plants was performed (Figure 3.2). A signature sequence, DGKQARRTGTSSPLGQLFDHGCN (residues 95-121), was found in the predicted amino acid sequence of cEPT. This sequence aligns well with the consensus sequence associated with CDP-alcohol phosphatidyltransferases, D-G-x(2)-A-R-x(8)-G-x(3)-D-x(3)-D. Proteins in this family are involved in phospholipid biosynthesis and share the property of catalyzing the displacement of CMP from a CDP-alcohol by a second alcohol, with formation of a phosphodiester bond and concomitant breaking of a phosphoride anhydride bond (Kodaki et al., 1987; Hjelmstad and Bell, 1991a). These enzymes include diacylglycerol cholinephosphotransferase (EC 2.7.8.2), phosphatidylglycerophosphate synthase (EC 2.7.8.5), phosphatidylserine synthase (EC 2.7.8.8), and phosphatidylinositol synthase (EC 2.7.8.11). These enzymes all contain from 200 to 400 amino acid residues. A conserved sequence region in *C. reinhardtii* EPT at positions 76-179 was also identified based on sequence homologies with other AAPTases (Figure 3.2). Similar conserved regions among the AAPTases have been proposed to contribute to the formation of the active site of the enzymes in the family of CDP-alcohol phosphatidyltransferases (Kodaki et al., 1987; Hjelmstad and Bell, 1991a). This region is predominantly hydrophilic but also contains one or two amphipathic structures which form α -helices that interact with the membrane on the cytoplasmic side of the ER. These analyses indicate that *C. reinhardtii* EPT clearly is a member of the CDP-alcohol phosphatidyltransferase family. A phylogram from the sequence alignment indicated that the *C. reinhardtii* EPT is more similar to mammalian CPT/EPT than to yeast EPT1 and CPT1 or plant AAPTases (Figure 3.3).

Figure 3.2 Sequence alignment of aminoalcoholphosphotransferases in different organisms. (A) Comparison of amino acid sequences among different organisms. cEPT, *C. reinhardtii* EPT (GenBank accession number AAQ83686); yCPT1, yeast CPT1 (AAA63571); yEPT1, yeast EPT1 (AAA63572); AtAAPT1, *Arabidopsis* AAPT1 (AAC61768); AtAAPT2, *Arabidopsis* AAPT2(AAC61769); GmAAPT1, soybean AAPT1 (AAA67719); BrAAPT1, *Brassica rapa* AAPT1 (AAB53764); hCPT/EPT, human CPT/EPT (AAD25170); mCPT/EPT, mouse CPT/EPT (accession number AAH21753). The CDP-alcohol phosphatidyltransferase signature in the sequences is underlined. The conserved sequence region shared by all the proteins in the family is indicated with asterisk. Residue numbers for amino acids are shown on the right. Gaps in alignments are indicated by dashes. Residues that are identical in six or more sequences are shaded in grey.

```

BrAAPT1 -----MGYIGAAGH-VAAALHRYKYSGVD 21
AtAAPT1 -----MGYIGAAGH-VAAALHRYKYSGVD 21
AtAAPT2 -----MGYIGAAGH-VAAALKKHKYSGVD 21
GmAAPT1 -----MGYIGTHG-VAAALHRYKYSGVD 21
yCPT1 -----MDSKTVLLTDSGETMGFFIPQSSLGNLKLYKYQSDD 36
yEPT1 -----MGYFVPSHIEHLKSYKYQSED 22
mCPT/EPT MSGHRSTRKRKCGDSDHPESPVGFGHMSTTGCVLNKLFLQPTPLSRHQLKRLLEHRYQSAG 60
hCPT/EPT MSGHRSTRKRKCGDSDHPESPVGFGHMSTTGCVLNKLFLQPTPLSRHQLKRLLEHRYQSAG 60
cEPT -----MVKVLSPRALEGLKNYVYKPGG 22

BrAAPT1 HSYLAKYVLPQFWTRFVKVFPPLWMPNMITLMGFMFLVTSSLLGYIYSPQLDSPPPRVH 81
AtAAPT1 HSYLAKYVLPQFWTRFVKVFPPLWMPNMITLMGFMFLVTSSLLGYIYSPQLDSPPPRVH 81
AtAAPT2 HSYLAKYVLPQFWNRVFKIFPLWMPNMITLMGFMFLTSALLGYIYSPKLDSPPRVH 81
GmAAPT1 HSYVAKYVLPQFWSRFVNFPLWMPNMITLMGFMFLLSALLGYIYSPQLDTAPPRVH 81
yCPT1 RSFLSNHVLRPFWRKFATIFPLWMAPNLVTLLGFCFLIFNVLTTLTYDPPYFQESPRWTY 96
yEPT1 RSLVSKYFLKPFWRQRFCHIFPTWMAPNITLISGFAFIVINVLTVFYDPPNLNTDTPRWTY 82
mCPT/EPT RSLLEP-LMQGYWEWLVRVPSWIAPNLITIIIGLSINICTTILLVFCPTATEQAPLWAY 119
hCPT/EPT RSLLEP-LMQGYWEWLVRVPSWIAPNLITIIIGLSINICTTILLVFCPTATEQAPLWAY 119
cEPT YTWLDH-AHTPFWNWLTALQPLMPLAPNLITLVLIVTFIAYGTMWYVLEPYTGEGERWPY 81
*****

BrAAPT1 FAHGLLLFLYQTFDAVDGKQARRTNSSSPLGELFDHGCDALACAFEAMAFGSTAMCGR-- 139
AtAAPT1 FAHGLLLFLYQTFDAVDGKQARRTNSSSPLGELFDHGCDALACAFEAMAFGSTAMCGR-- 139
AtAAPT2 FAHGLLLFLYQTFDAVDGKQARRTNSSSPLGELFDHGCDALGCALETMAYGSTAMCGR-- 139
GmAAPT1 FAHGLLLFLYQTFDAVDGKQARRTNSSSPLGELFDHGCDALACTFEALAFGSTAMCGR-- 139
yCPT1 FSYAIGFLYQTFDADCGMHARRTGQQPLGELFDHCIDSINTTSLMIPVCSMTGMGYT- 155
yEPT1 FSYALGVFLYQTFDGDGVHARRINQSGPLGELFDHSIDAINSTLSIFIFASETGMGFS- 141
mCPT/EPT IACACGLFIYQSLDAIDGKQARRTNSSSPLGELFDHGCDLSSTVFVVLGTCIAVQLGTNP 179
hCPT/EPT IACACGLFIYQSLDAIDGKQARRTNSSSPLGELFDHGCDLSSTVFVVLGTCIAVQLGTNP 179
cEPT FAFAGVSIILVYTNLDCIDGKQARRTGTSSPLGQLFDHGCDAAVALHVMLSLVQASLAEPSP- 140
*****

BrAAPT1 -DTFWFVVISAIPIFYGATWEHYFTNTLILP-VINGPTEGLALIFVSHFFTAIVGAEWAAQ 197
AtAAPT1 -DTFWFVVISAIPIFYGATWEHYFTNTLILP-VINGPTEGLALIFVSHFFTAIVGAEWAAQ 197
AtAAPT2 -DTFWFVVISAVPFFGATWEHYFTNTLILP-VVNGPTEGLALICYGHFFTAIVGAEWAAQ 197
GmAAPT1 -TTFWWWLISAITFYGATWEHYFTNTLILP-VINGPTEGLMIYICHHFFTAIVGAEWVQ 197
yCPT1 YMTIFSQFAILCSFYLSTWEEYHHTHKLILA-EFCGPEVEGIIVLCISFIAVGIYGPQTIWH 214
yEPT1 YNLMLSQFAMLTNFYLSSTWEEYHHTHLYLS-EFSGPEVEGILIVCVSLILTGIYKQVVIWH 200
mCPT/EPT DWMFFCCFAGTFMFYCAHWQTYVSGTLRFG-IFD-VTESQILILFQLLSGTVGPWFVNF 237
hCPT/EPT DWMFFCCFAGTFMFYCAHWQTYVSGTLRFG-IID-VTEVQIFIIMHLLAVTGGPPFVQS 237
cEPT VFASVAAMSVYLPWWVSHWEEYHTGVLMYGDGNFCILEANYVLALVTFITGTGFPAMWDT 200
*****

BrAAPT1 QLGQSIPLFSWVFFVNAIQTSRAVLYMMIAFAVIPTVAFNVSNVYKVVQSRKGSMLLALA 257
AtAAPT1 QLGQSIPLFSWVFFVNEIQTSRAVLYMMIAFAVIPTVAFNVSNVYKVVRSRNGSMVLALA 257
AtAAPT2 PFGKSIPLFSWVFFLNEMQMSRIILFSMIFFAVIPTLAINTSNVYKVVHSRNGSMLLALA 257
GmAAPT1 QFGKSLPFLNWLPLYGGIPTFKAILCLMIAFGVTPVTVCNVSNVYKVVKGKNGSMPLALA 257
yCPT1 TKVAQFSWQDFVFDVETVHLMYAFCTGALIFNIVTAHTNVVRYYESQSTKSATPSKTAEN 274
yEPT1 TYLFTITVGDKVIDVDVTLDIVSLAVFGLVMNALSAKRNVDKYRNRN-STSSAN-NITQIE 258
mCPT/EPT TIPVLNIQMKLLPALCTVAGTIFSCTNYFRVIFTGGVGKNGSTIAG-----TSVLS 288
hCPT/EPT MIPVLNIQMKLIPALCTVAGTIFSCTNYFRVIFTGGVGKNGSTIAG-----TSVLS 288
cEPT PMRSIVPVFPWDTSVKHAFIVFAMICIALIQNYGQLYRVFSRHWTMLPEAERGHKELGNAS 260

BrAAPT1 MLYPFVVLGGVLIWDYLSPINLIET--YPHLVVLGTGLAFGFLVGRMILAHLCDEPKGL 315
AtAAPT1 MLYPFVVLGGVLIWDYLSPINLIAT--YPHLVVLGTGLAFGFLVGRMILAHLCDEPKGL 315
AtAAPT2 MLYPLVTLIAGVLIWDYLSPIDLIRN--YPHLVVLGTGLAFGFLVGRMILAHLCDEPKGL 315
GmAAPT1 MLYPFVVLGGVLVWDYLSPSDIMGK--YPHLVVIGTGLTFGYLVGRMILAHLCDEPKGL 315
yCPT1 ISKAVNGLLPFFAYFSSIFTLVLIQPSFISLALILSICFVSFAFVVGRIIAHLMQPFPM 334
yEPT1 QDSAIAKGLLPFFAYYASIALLVMMQPSFITLSFILSVGFTGAFTVGRITVCHLTKQSFPM 318
mCPT/EPT PFLHIGSVITLAVMIYKKSAVQLFEK--HPCLYILTFGFVSAKITNKLVVAHMTKSEMHL 346
hCPT/EPT PFLHIGSVITLAAAMIYKKSAVQLFEK--HPCLYILTFGFVSAKITNKLVVAHMTKSEMHL 346
cEPT RLTHLASGAALIFLGAVYLADNKLQPG-QARLAGLLYGLVYAVIVATQLIMDHMCKEP--F 317

```

BrAAPT1	KTNMCLSLVYLPFALANALTARLNDGVPLVDELWVLLGYCIFTVSLYLHFATSVIHEITT	375
AtAAPT1	KTNMCSLLYLPFALANALTARLNAGVPLVDELWVLLGYCIFTVSLYLHFATSVIHEITE	375
AtAAPT2	KTNMCSLLYLPFALANALTARLNDGVPLVDEFWVLLGYCIFTLSLYAHFATSVIHEITT	375
GmAAPT1	KTGMCSLMFLPLAIANVLASRLNDGVPLVDERLVLLGYCAFSVTLYLHFATSVIHEITN	375
yCPT1	VN-FPFLIPTIQLVLYAFMVYVLDYQKGSIVSALVWMGLG-LTLAIHGFMINDIYDITT	392
yEPT1	FN-APMLIPLCQIVLYKICLSLWGIESNKIVFALSWMGLG-LSLGVHIMFMNDIHEFTE	376
mCPT/EPT	HD-TAFIGPALFLDQYFNSFIDEYIWLWIALIFSFFDLIRYCVSVCNQIASHLHIHVFR	405
hCPT/EPT	HD-TAFIGPALFLDQYFNSFIDEYIWLWIALVFSFFDLIRYCVSVCNQIASHLHIHVFR	405
cEPT	RSPLPLAVLTVAAANSVLQLVDARATAATLAGAMIVYYLVVYVTTIVDQVCAYLGKICLT	377
BrAAPT1	ALGIYCFRITRKEA-	389
AtAAPT1	ALGIYCFRITRKEA-	389
AtAAPT2	ALGIYCFRITRKEA-	389
GmAAPT1	ALGIYCFRITRKEA-	389
yCPT1	FLDIYALSISKHPKEI	407
yEPT1	YLDVYALSISKSKLT	391
mCPT/EPT	IKASTAHSNHH----	416
hCPT/EPT	IKVSTAHSNHH----	416
cEPT	ITPKRA-----	383

Similarities in membrane-associated topography also are predicted among yeast EPT1, yeast CPT1, human CPT/EPT protein, mouse CPT/EPT, *Arabidopsis* AtAAPT1 and AtAAPT2, soybean AAPT1, *Brassica rapa* AAPT1 and *C. reinhardtii* EPT based on their hydropathy profiles and prediction of secondary structures. In particular, yeast EPT1 and CPT1, soybean AAPT1, *Arabidopsis* AAPT1 and AAPT2 and human CPT/EPT all share similar topological structures with seven membrane-spanning regions (Hjelmstad and Bell, 1990, 1991a; Dewey et al., 1994; Goode and Dewey, 1999; Henneberry and McMaster, 1999), and *C. reinhardtii* appears to follow this same profile. As an example, the parallel patterns of hydrophobicity and transmembrane domain allocations in the amino acid sequences of cEPT, yeast EPT1 and CPT1 are demonstrated (Figure 3.4). The locations of the seven apparent transmembrane domains in cEPT polypeptide are: TM1 (residues 45-67), TM2 (176-198), TM3 (218-240), TM4 (261-280), TM5 (290-309), TM6 (322-341), TM7 (351-373). These domains are located in very similar positions within the protein sequences of all three polypeptides. These results indicate a high degree of conservation in the membrane associated topography of the aminoalcoholphosphotransferases in these organisms. Based on these considerations and previous protease experiments (Vance et al., 1977; Coleman and Bell, 1978; Bell et al., 1980), the catalytic site would, as anticipated, be located on the cytoplasmic side of the ER between TM1 and TM2, as initially proposed (Hjelmstad and Bell, 1991a).

The site of PE biosynthesis is defined by the intracellular location of EPT. EPT activity has consistently been found associated with the microsomal membrane fraction and most studies show that EPT is located in the ER. Since EPT activity cannot be obtained from biological membranes without the addition of detergents sufficient to

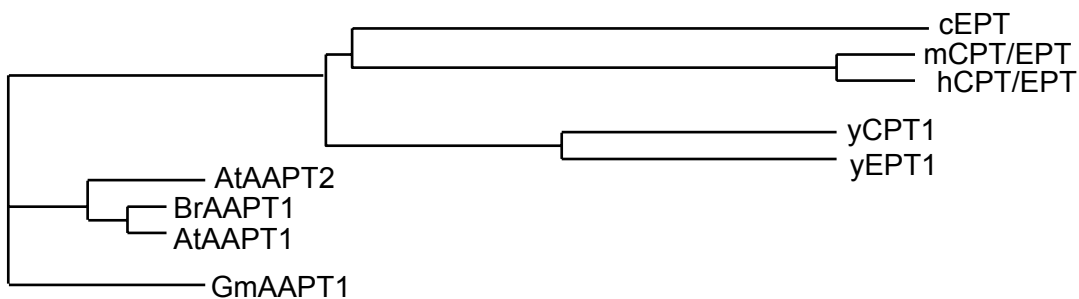

Figure 3.3 Phylogram of aminoalcoholphosphotransferases in different organisms.

The phylogram was obtained from the complete amino acid sequence alignment as described in Figure 3.3. cEPT, *C. reinhardtii* EPT (GenBank accession number AAQ83686); yCPT1, yeast CPT1 (AAA63571); yEPT1, yeast EPT1 (AAA63572); AtAAPT1, *Arabidopsis* AAPT1 (AAC61768); AtAAPT2, *Arabidopsis* AAPT2(AAC61769); GmAAPT1, soybean AAPT1 (AAA67719); BrAAPT1, *Brassica rapa* AAPT1 (AAB53764); hCPT/EPT, human CPT/EPT (AAD25170); mCPT/EPT, mouse CPT/EPT (AAH21753).

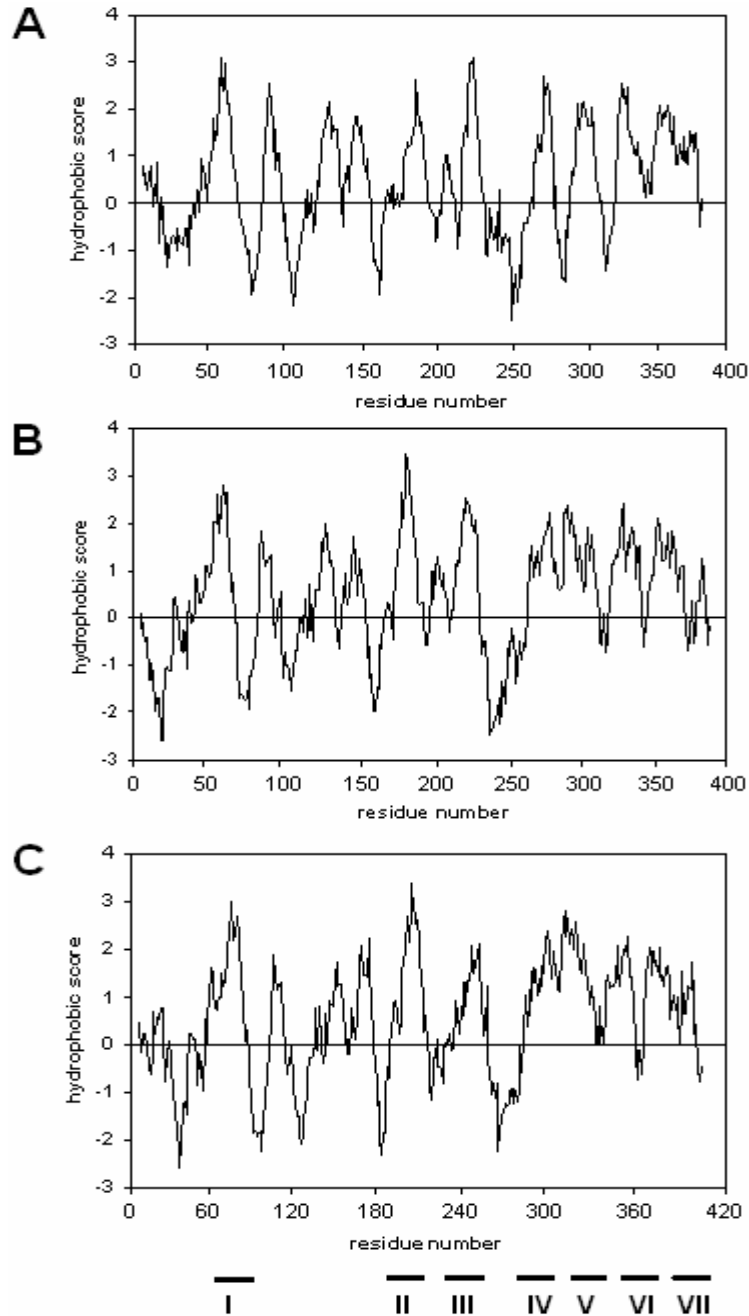

Figure 3.4 Hydropathy profile of the predicted *C. reinhardtii* EPT protein and yeast EPT1 and CPT1. Hydrophobicity was analyzed by the method from Kyte and Doolittle (1982) using a window size of nine residues. Positive values represent hydrophobicity. The seven candidate transmembrane domains for the three polypeptides are indicated as I to VII. (A) *C. reinhardtii* EPT. (B) Yeast EPT1. (C) Yeast CPT1

completely dissolve the lipid bilayer, its occurrence as an integral protein was suggested (Vance and Vance, 1988; Mancini et al., 1993) and this is supported by the topography predictions presented above. It has been shown that in mammalian cells and yeast, EPT has an absolute requirement for phospholipids, presumably associated with its seven transmembrane domains (Hjelmstad and Bell, 1991a; McMaster et al., 1996; Henneberry and McMaster, 1999). A prediction of 67% probability of the endoplasmic reticulum as the subcellular localization of the *C. reinhardtii* EPT protein, and 33% for the plasma membrane, was obtained using the *k*-nearest neighbor (*k*-NN) algorithm for assessing the probability of localizing at each of the candidate sites (Horton and Nakai, 1997). In addition, a KKXX-like motif representative of a type of ER membrane retention signal, TPKR, was found in the C-terminus of the protein (position 379-382). Moreover, the membrane topology of the EPT protein was predicted to have the N-terminus of the protein located inside the ER membrane. These results all support the *C. reinhardtii* EPT as being an integral membrane protein of the endoplasmic reticulum.

Southern blot analysis of genomic DNA indicated that a single *EPT* gene is present in the genome of *C. reinhardtii*, suggesting that there are no other AAPTases in this species (Figure 3.5A). Comparisons of the *EPT* cDNA sequence with genomic databases provided the complete genomic sequence of the *EPT* gene from *C. reinhardtii*. As seen in the gene organization diagram (Figure 3.5B), the *EPT* gene of *C. reinhardtii* has six introns ranging from 143 to 303 bp in length, while the seven exons vary in size between 107 and 906 bp.

b. Complementation of a Yeast Mutant with the *EPT* cDNA

In order to demonstrate the function of the mature cEPT protein encoded by the

C. reinhardtii *EPT* gene, complementation of a yeast strain deficient in both EPT1 and CPT1 activity was conducted. Since yeast has both a cholinephosphotransferase (CPT1) and an ethanolaminephosphotransferase (EPT1) and its EPT1 has a cholinephosphotransferase activity that is over 50% as active as its ethanolaminephosphotransferase activity (Hjelmstad and Bell, 1988), it was essential that the yeast strain used in complementation be mutated at both the *EPT1* and *CPT1* loci. This removes all the endogenous activities of the two phosphotransferases. Yeast strains deficient in either EPT1 or CPT1 activity were previously obtained by ethyl methanesulfonate-mediated mutation of yeast cells (Hjelmstad and Bell, 1987, 1988). A double-mutant haploid strain RK-ec has been generated from a cross between two single-mutant strains, RH-6D (*MAT α* , *cpt1*, *his3- Δ 1*, *leu2-3*, *leu2-112*, *ura3-52*) for CPT1, and HJ729 (*MAT α* , *ept1*, *gal*⁻, *his3- Δ 1*, *leu2-3*, *leu2-112*, *ura3-52*, *trp-289*) for EPT1 (Dewey et al, 1994). This double mutant strain was used for our complementation studies.

The *C. reinhardtii* *EPT* cDNA coding sequence was cloned into a *Hind* III site immediately after the *ADHI* promoter of the yeast expression vector pDB20 (Becker et al., 1991). This construct was used to transform yeast strain RK-ec and the transformants were selected on a selection medium lacking uracil. These transformed colonies were screened for cholinephosphotransferase activity by colony autoradiography. This approach depended on the *C. reinhardtii* EPT behaving similarly to soybean and *Arabidopsis* AAPTases in previous studies, relying on the fact that these enzymes had both ethanolaminephosphotransferase and cholinephosphotransferase activities, thereby replacing both enzymes. Both of the *Arabidopsis* AAPTases (AtAAPT1 and AtAAPT2) actually had a higher preference for CDP-choline than for

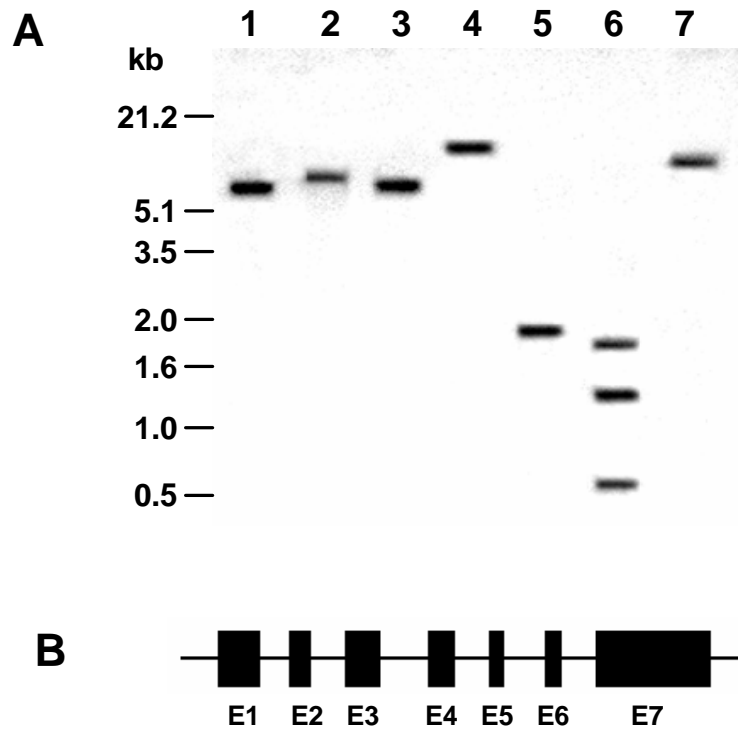

Figure 3.5 Southern blot analysis of the *EPT* gene in the genome of *C. reinhardtii* wild type strain 137C and the *EPT* gene structure. (A) Genomic DNA was digested by *EcoRI* (lane 1), *EcoRV* (lane 2), *HindIII* (lane 3), *XmnI* (lane 4), *PvuII* (lane 5), *PstI* (lane 6) and *XhoI* (lane 7), separated on a 0.8% agarose gel, transferred to a Nytran membrane, and hybridized to a radiolabeled 1.1-kb probe from PCR of the coding region of *EPT* cDNA. (B) Genomic structure of the *C. reinhardtii* *EPT* gene. The seven exons are labeled E1-E7. The GenBank accession number is AY375473.

CDP-ethanolamine (Dewey et al., 1994; Goode and Dewey, 1999). As shown in Figure 3.6, the yeast mutant strain RK-ec, deficient in both EPT1 and CPT1 activities, was complemented in colonies from cells transformed with the pDB-EPT construct, while the RK-ec strain without transformation and the RK-ec transformed with empty vector pDB20 had no detectable cholinephosphotransferase activity. Cholinephosphotransferase activity was clearly observed, as a positive control, using a wild type strain of yeast, KT1115. TLC assays of the chloroform-methanol extracted radiolabeled PC from the filter paper demonstrated that more than 95% of the radiolabeled PC product co-migrated with a PC standard (data not shown).

c. Inhibition of EPT by CDP-aminoalcohols and CMP

Accumulated evidence indicates that in higher plants a single enzyme is responsible for both ethanolaminephosphotransferase and cholinephosphotransferase activities (Sparace et al., 1981; Justin et al., 1985; Dewey et al., 1994; Goode and Dewey, 1999). In these studies, it has been demonstrated that both CDP-choline and CDP-ethanolamine competitively inhibit ethanolaminephosphotransferase and cholinephosphotransferase activities. This also appears to be true for *C. reinhardtii*, since CDP-choline was clearly incorporated into yeast cells expressing the *C. reinhardtii* EPT gene, as visualized by the colony autoradiographic assay (Figure 3.6).

In order to further define this variable substrate specificity, we tested the effects of unlabeled CDP-ethanolamine and CDP-choline on radiolabeled CDP-choline incorporation into PC catalyzed by phosphotransferase contained in microsomal membranes purified from yeast RK-ec transformed with pDB-EPT. Microsomal membranes prepared from the yeast strains RK1115, RK-ec transformed with pDB-EPT

along with *C. reinhardtii* strain CC-406 cw15 (*mt*⁻), were assayed for PC biosynthesis using [¹⁴C]-CDP-choline and reduction of CDP-choline incorporation by addition of unlabeled competitive substrates. The results clearly demonstrated that increasing concentrations of either unlabeled CDP-choline or CDP-ethanolamine reduced the synthesis of radiolabeled PC in microsomes from yeast KT1115, RK-ec transformed with pDB-EPT and *C. reinhardtii* (Figure 3.7). When microsomal membranes from *C. reinhardtii* were similarly tested, the results were comparable to those using microsomal membranes from the yeast strain RK-ec expressing the *C. reinhardtii* EPT gene (Figure 3.7B and 3.7C). In contrast, in the yeast strain KT1115 a reduction in formation of radiolabeled PC by CDP-ethanolamine was much less than that resulting from addition of CDP-choline (Figure 3.7A). The microsomal membranes from yeast RK-ec and RK-ec transformed with pDB-20 showed no detectable cholinephosphotransferase activity (data not shown). Collectively, these data support the hypothesis that the *C. reinhardtii* EPT is more similar to plant phosphotransferases in substrate preferences, which are less selective, than it is to the enzyme from other sources, particularly yeast (Sparace et al., 1981; Dewey et al., 1994; Goode and Dewey, 1999; Hjelmstad and Bell, 1991b).

The effects of increasing concentrations of the water-soluble product of the EPT-catalyzed reaction, CMP, on the cholinephosphotransferase activity of microsomes from yeast KT1115, RK-ec transformed with pDB-EPT and *C. reinhardtii* strain CC-406 cw15 (*mt*⁻) were tested. Increasing CMP concentration resulted in a decrease in the cholinephosphotransferase activity of microsomal membranes from both yeast RK-ec transformed with pDB-EPT expressing *C. reinhardtii* EPT and *C. reinhardtii* cells in a similar manner (Figure 3.8). On the other hand, yeast KT1115 microsomes responded

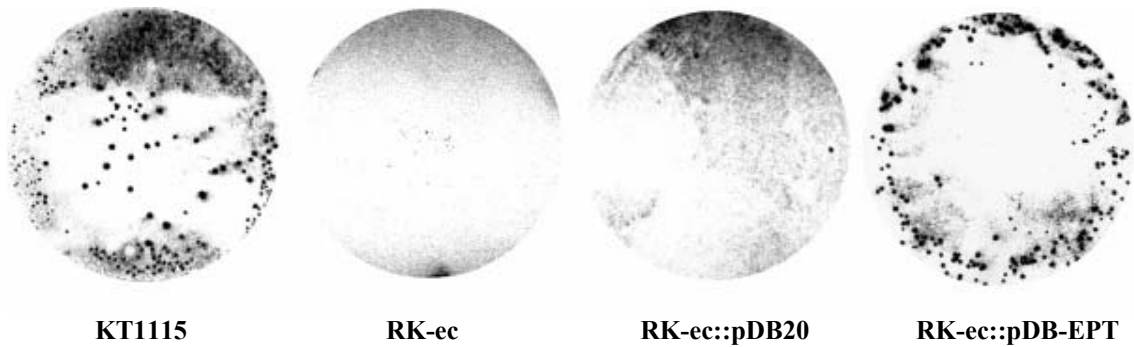

Figure 3.6 Colony autoradiographic assays for CPT activity in yeast. Yeast strain KT1115 and RK-ec transformed with pDB20 served as positive and negative controls, respectively. Yeast colonies of all strains used here were grown on YP-Glucose medium containing glucose as the sole carbon source. Filters were exposed to X-ray film at -80°C for 4 days before development.

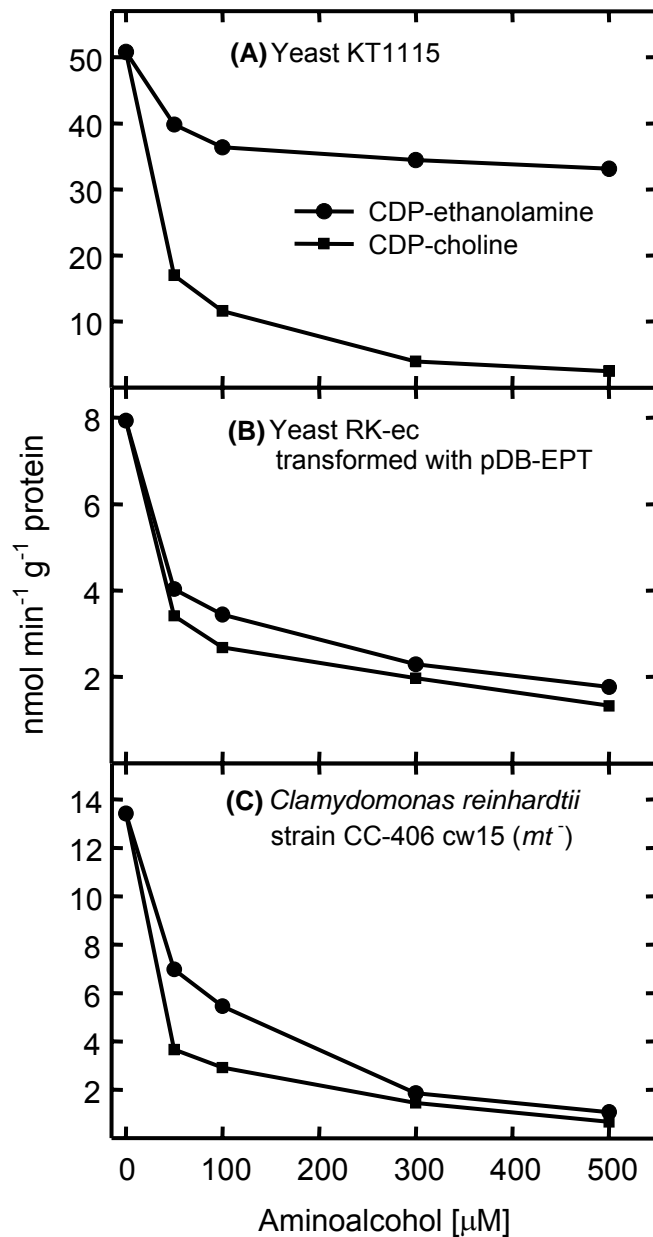

Figure 3.7 Effect of CDP-choline and CDP-ethanolamine on the incorporation of [¹⁴C]-CDP-choline into PC by *C. reinhardtii* EPT and yeast EPT/CPT enzymes. Microsomal membranes were prepared from yeast strains of KT1115, RK-ec:: pDB-EPT and *C. reinhardtii* strain CC-406 cw15 (*mt*⁻) as described in “Materials and Methods”. Enzymatic assays for cholinephosphotransferase were carried out for microsomal membranes at increasing concentrations of unlabeled CDP-ethanolamine (●) or unlabeled CDP-choline (▲). (A) Yeast strain KT1115. (B) Yeast strain RK-ec transformed with pDB-EPT. (C) *C. reinhardtii* strain CC-406 cw15 (*mt*⁻).

much less to increasing concentrations of CMP than did yeast RK-ec transformed with pDB-EPT or *C. reinhardtii* EPT. These results indicate that the algal enzyme is different from that of the yeast, and that the *C. reinhardtii* EPT was not altered in the yeast cells with respect to its substrate preference and sensitivity to CMP.

Discussion

Plants, animals and fungi have different types of AAPTases involved in the final step of the nucleotide pathways for PE and PC biosynthesis. In animals and yeast, it appears that two independent AAPTases primarily use different substrates, CDP-choline and CDP-ethanolamine, for synthesis of PC and PE, respectively (Bell and Coleman, 1980; Percy et al., 1984; Hjelmstad and Bell, 1990, 1991a, 1991b). In higher plants, some evidence indicates that the final step in the Kennedy pathway of PC and PE biosynthesis is catalyzed by a single enzyme, while other evidence supports the involvement of separate enzymes in this process (Macher and Mudd, 1974; Lord, 1975; Dykes et al., 1976; Harwood, 1976; Sparace et al., 1981; Justin et al., 1985; Goode and Dewey, 1999).

Indirect evidence has been of particular importance to the above conclusions, particularly the observations that a single enzyme can use both CDP-choline and CDP-ethanolamine to synthesize PC and PE, respectively, and that either CDP-choline or CDP-ethanolamine could serve as competitive inhibitors of the other's incorporation in EPT- and CPT-catalyzed reactions. In addition, in higher plants it has been shown that two additional CDP-ethanolamine analogs, CDP-methylethanolamine and CDP-dimethylethanolamine, may also serve as substrates for these same enzymes, leading to

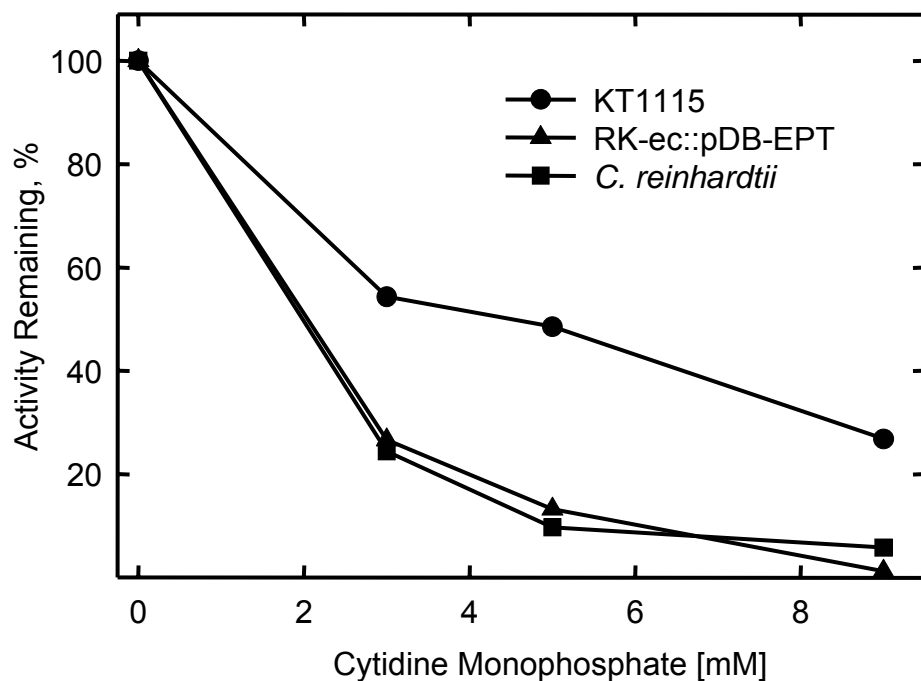

Figure 3.8 Effect of CMP on the incorporation of [14 C]-CDP-choline into PC by *C. reinhardtii* EPT and yeast EPT/CPT enzymes. Enzymatic assays for cholinephosphotransferase were conducted in the presence of increasing concentrations of CMP and incubated at 30°C for 20 min. Relative activity in percentage is expressed in comparison to a reaction that does not contain CMP. Activities of 100% were 57.4, 10.4 and 15.2 nmol min⁻¹ g⁻¹ protein for microsomal membranes prepared from yeast KT1115 (●), RK-ec transformed with pDB-EPT (▲) and *C. reinhardtii* CC-406 cw15 (*mt*) (■), respectively.

production of phosphatidylmethylethanolamine and phosphatidyl dimethylethanolamine, which may then be converted to PC by *N*-methyltransferases (Prud'homme and Moore, 1992). The major pathways of PC synthesis appear to be different among the various species of higher plants that have been studied, including soybean, *Lemna paucicostata*, carrot and castor bean endosperm. In soybean CDP-methylethanolamine appears to be the primary substrate of AAPTase in production of PC, while in *Lemna paucicostata* and castor bean endosperm the major substrate is CDP-choline, and in carrot all three CDP-aminoalcohols, methylethanolamine, dimethylethanolamine and choline, are involved in the biosynthesis of PC (Datko and Mudd, 1988a, 1988b; Prud'homme and Moore, 1992).

The current investigation was initiated because *C. reinhardtii* synthesizes no PC, but does produce PE. This simplifies all interpretations and allows a more direct observation of the activity of EPT itself. Interestingly, the EPT enzyme of *C. reinhardtii* has very high cholinephosphotransferase activity, as demonstrated by its use of [¹⁴C]-CDP-choline in the colony autoradiographic assays and the inhibition assays with CDP-aminoalcohols and CMP. This result is similar to those obtained when the soybean *AAPT1* gene was expressed in the same yeast strain, RK-ec (Dewey et al., 1994). Since both CDP-choline and CDP-ethanolamine reduced [¹⁴C]-CDP-choline incorporation into [¹⁴C]-PC when added to a reaction mixture containing microsomal membranes from transformed strain RK-ec with pDB-EPT or *C. reinhardtii*, it is clear that the EPT enzymes can utilize either substrate well. By contrast, the yeast KT1115, which possesses both EPT1 and CPT1, demonstrated differential effects of CDP-choline and CDP-ethanolamine on [¹⁴C]-PC biosynthesis in that inhibition by CDP-ethanolamine was much less than that by CDP-choline. This response is undoubtedly complex, however,

due to the presence of the two separate phosphotransferases, as well as differences in their respective total activities and substrate affinities (Hjelmstad and Bell, 1987, 1988).

Yeast mutant strains deficient in either EPT1 or CPT1 activity due to single mutations in the *EPT1* and *CPT1* loci have been characterized in similar competition assays with CDP-choline and CDP-ethanolamine (Dewey et al., 1994). We have found that the inhibition patterns from KT1115, RK-ec transformed with pDB-EPT and *C. reinhardtii* differ significantly from those yeast single mutant strains deficient in either EPT1 or CPT1. More specifically, the cholinephosphotransferase activity of yeast deficient in CPT1 and EPT1, but transformed with the *C. reinhardtii* EPT gene, demonstrates different susceptibilities to CDP-ethanolamine or CDP-choline than do yeast mutants expressing either the *CPT1* or *EPT1* genes. It was also demonstrated that the cholinephosphotransferase activity from yeast *EPT1* in the mutant strain HJ110, which was deficient in CPT1 activity but contained normal EPT1 activity, was reduced to a greater degree by CDP-ethanolamine than by CDP-choline at any concentration when compared with the soybean AAPT1-encoded enzyme (Dewey et al., 1994). The yeast mutant HJ729, deficient in EPT1 but with normal CPT1 activity, had no reduction in incorporation of CDP-choline as a result of adding nonradioactive CDP-ethanolamine (Dewey et al., 1994). The inhibition profile of [¹⁴C]-CDP-choline incorporation by the *C. reinhardtii* EPT gene was similar to that observed with soybean AAPT1; that is, the cholinephosphotransferase activity of cEPT was inhibited to a slightly greater extent by CDP-choline than by CDP-ethanolamine in the transformed yeast system.

In summary, the *C. reinhardtii* EPT is clearly different from the yeast EPT1 or CPT1. Of the two yeast enzymes, the *C. reinhardtii* EPT appears more closely related to

the yeast EPT1, which also has both ethanolaminephosphotransferase and cholinephosphotransferase activities. However, one difference between the two enzymes is that the EPT1 of CPT1-deficient yeast demonstrated a higher specificity for CDP-ethanolamine than for CDP-choline, but *C. reinhardtii* EPT demonstrated about equal specificities. Since *C. reinhardtii* does not contain PC, this very high native cholinephosphotransferase activity of the *EPT* gene product may provide interesting information for studying the evolution of *C. reinhardtii* and other algal species.

The information reported here from cloning and characterization of the *C. reinhardtii* *EPT* cDNA will provide a basis for further studies on the structure and regulation of the gene coding for the enzyme catalyzing the final step in the CDP-ethanolamine pathway of PE biosynthesis, and the enzyme itself. In addition, the *EPT* cDNA will allow more specific investigations of substrate specificities and kinetics of the enzyme of an algal species, providing reference information for understanding and investigating the regulation of the Kennedy pathway for both PC and PE biosynthesis in plants and animals. Finally, such studies will facilitate evolutionary studies by elucidating the changes in and roles of phospholipid composition, and its regulation, during growth and development.

CHAPTER 4

CONCLUSIONS

Chlamydomonas reinhardtii has no PC or PS in its membranes. However, it does have PE and a CDP-ethanolamine pathway is present for its biosynthesis. Since a single copy of the *ECT* gene is found in the genome of the green alga, there is no other isoform of ECT in *C. reinhardtii* cells. This situation makes the *C. reinhardtii* a valid system for studying the *ECT* gene structure, function and regulation independent of the PC and PS synthesis pathways that are interrelated with those of PE in other organisms. The present study proved an effective system which allowed for simple and convenient gene isolation, enzyme assays and data interpretation.

A search of the available *C. reinhardtii* genomic database indicates that the absence of PC is due to the lack of the genes that encode the enzymes of the biosynthetic pathway for PC. No genes coding for the three enzymes in the CDP-choline pathway of PC biosynthesis, choline kinase, CTP: phosphocholine cytidyltransferase and cholinephosphotransferase, are found in the genome of *C. reinhardtii*. However, the absence of the CDP-choline pathway for PC synthesis may be due to the absence of only a single enzyme, CTP: phosphocholine cytidyltransferase, which catalyzes the second step of the pathway, since it is possible that the first and the last step in both the CDP-choline pathway and the CDP-ethanolamine pathway may be catalyzed by the same enzyme as demonstrated in mammalian and plant cells (Ishidate, 1997; Lord, 1975; Goode and Dewey, 1999). The third enzyme of the CDP-ethanolamine pathway in *C. reinhardtii*, EPT, has proven to be capable of catalyzing PC synthesis using CDP-choline as a substrate (Moore et al., 2001). The lack of PC and presence of PE in *C. reinhardtii*

may be useful for further study of the phospholipid biosynthesis and regulation.

To date there have been no reports of multiple isoforms of ECT in any organism that has been studied. By contrast, the analogous enzyme, CCT, in the CDP-choline pathway occurs in three isoforms (alpha, beta1, beta2) in mammalian cells and their regulatory mechanisms appear different (Clement and Kent, 1999). This indicates that the regulation of ECT may be different from that of CCT, and that the CDP-ethanolamine pathway for PE synthesis is regulated independently of the CDP-choline pathway for PC biosynthesis (Vermeulen et al., 1997; Vance, 2003). Several early studies proposed that ECT catalyzes the rate-limiting step of the CDP-ethanolamine pathway (Sundler and Akesson, 1975; Tijburg et al., 1987) although it remains possible that the other step in the pathway may also be regulated. It also has been suggested, on the basis of theoretical considerations, that both the first reaction catalyzed by ethanolamine kinase, and the second catalyzed by ECT, could be regulated in rat liver (Infante, 1977). Some evidence supports such a model, such as in hamster heart the ethanolamine kinase (EK) activity regulates the flux of ethanolamine through the CDP-ethanolamine pathway (McMaster and Choy, 1992). Furthermore, the overexpression of EK in human COS-7 cells results in a 170-fold increase in ethanolamine kinase-specific activity and accelerates the rate of labeled ethanolamine incorporation into PE as a function of the ethanolamine concentration in the culture medium, indicating that ethanolamine kinase can be a rate-controlling step in PE biosynthesis (Lykidis et al., 2001).

The current investigation did not study EK in the CDP-ethanolamine pathway. The studies of *EK* gene and its product may be a logical extension of the work described here. A putative gene coding for EK is found in the genome of *C. reinhardtii*. The

availability of the *C. reinhardtii* genomic database makes it possible to locate the chromosomal positions of the three genes encoding EK, ECT and EPT enzymes involved in CDP-ethanolamine pathway. The *EK* gene appears in a different scaffold from the *ECT* and *EPT* genes, which are close to each other in a separate scaffold (Figure 4.1). The *EK* gene also appears in a different linkage group from the *ECT* and *EPT* genes. Therefore, it is likely that the *EK* gene is in a different chromosome from the *ECT* and *EPT* genes. The distance between the *ECT* and *EPT* genes (about 46 kb) is too far for the two genes to be interrelated in regulation on the chromosome. Therefore, it is unlikely that the three genes coding for the three enzymes in CDP-ethanolamine pathway are coordinately regulated on the chromosome.

The present study demonstrated that ECT may be regulated at both the transcriptional and posttranslational levels. This is the first evidence for ECT regulation at the transcriptional level. Limited cases for the transcriptional regulation of a similar enzyme, CCT in the CDP-choline pathway, have been reported in mammalian cells. In these studies, it was observed that *CCT* mRNA increased mainly due to the stabilization of *CCT* mRNA (Tessner et al., 1991) and that an increase in expression of a phosphatidylethanolamine *N*-methyltransferase resulted in decreased levels of *CCT* mRNA (Garbay and Cassagne, 1994). A number of studies have shown that the CDP-choline pathway can be regulated at the level of CCT activity (Clement and Kent, 1999). The major regulation of CCT in the CDP-choline pathway has been the translocation of the enzyme between ER membranes, where CCT is in an active membrane-bound form, and the cytoplasm, where CCT is in a soluble inactive form (Kent, 1990; Vance, 1996; Cornell and Northwood, 2000). This translocation of CCT between the ER and

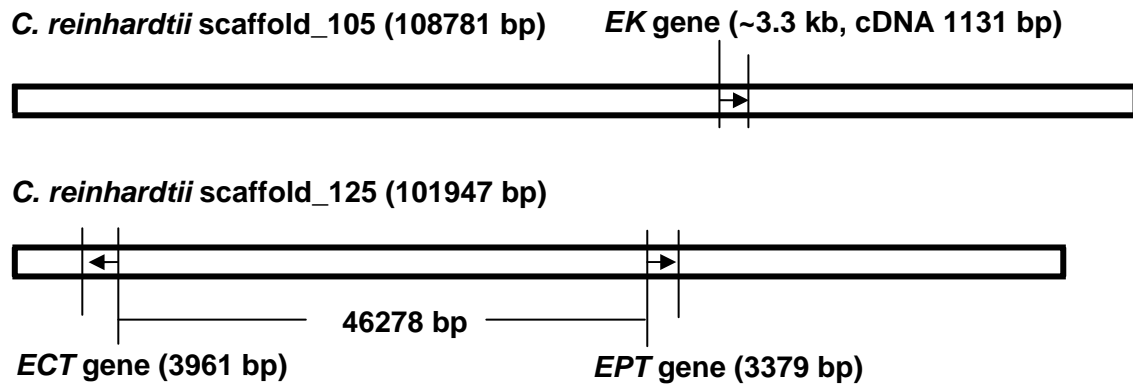

Figure 4.1 Locations of *EK*, *ECT* and *EPT* genes in *Chlamydomonas reinhardtii* genome. *EK*: ethanolamine kinase, *ECT*: CTP: phosphoethanolamine cytidyltransferase, *EPT*: ethanolaminephosphotransferase.

cytoplasm has been shown to be mediated by a number of factors such as the PC content in the membranes, phosphorylation-dephosphorylation of the CCT protein, and concentrations of diacylglycerol (Clement and Kent, 1999). However, no evidence has been provided to show that the ECT enzyme activity can be regulated in a similar manner although several studies reported that cytosolic ECT can partially associate with ER membranes (Vermeulen et al., 1993; van Hellemond et al., 1994). In addition, in contrast to CCT, the activity of ECT is not regulated by lipids (Vermeulen et al., 1993). One remaining possibility is that the regulation of ECT occurs by a phosphorylation-dephosphorylation cycle, but no investigations have been conducted to determine if ECT can be phosphorylated in vivo. Another possible factor is the concentration of diacylglycerol in the cells since it is the substrate of the ECT enzyme and its presence may be under control of fatty acid availability. It has been observed that diacylglycerol may limit the rate of PE biosynthesis by the CDP-ethanolamine pathway under certain conditions (Tijburg et al., 1989a).

Since the final enzyme in this pathway, EPT, is an integral microsomal enzyme, reversible binding of ECT to the ER membranes could play a key role in the regulation of the CDP-ethanolamine pathway in some organisms. In this study, it was observed that most ECT activity is in the mitochondrial fraction of the *C. reinhardtii* cells, which is consistent with the presence of a signaling sequence in the protein. This does not rule out a possibility that some ECT may also be in cytoplasm where it functions in the CDP-ethanolamine pathway for PE synthesis by providing the substrate for the third enzyme that is located in the ER. Most previous studies of ECT in mammalian cells suggest that ECT is basically a cytoplasmic enzyme and may be associated with ER membranes for

PE production in the CDP-ethanolamine pathway (Vermeulen et al., 1993; van Hellemond et al., 1994). Studies of ECT in castor bean endosperm indicated that ECT is mainly associated with mitochondria, but also occurs in the ER (Wang and Moore, 1991; Tang and Moore, 1997). The mitochondrial location of ECT in plants and *C. reinhardtii* suggests a possibility that ECT plays a role in some other cellular processes other than its catalytic function in the CDP-ethanolamine pathway for PE biosynthesis. However, whether ECT is located in the cytoplasm of mammalian cells or in mitochondria of plant cells, it is essential that CDP-ethanolamine be moved to the ER to perform its function in the CDP-ethanolamine pathway, since the third enzyme of the pathway, EPT, is clearly localized in ER membranes. Here, based on the potential locations of ECT and EPT in *C. reinhardtii* cells and previous studies of ECT in mammals and plants, a working model is proposed for the PE biosynthesis in *C. reinhardtii* (Figure 4.2). In this model, the ECT translocates between the mitochondria and ER to participate in the CDP-ethanolamine pathway for PE biosynthesis. The final step is catalyzed by the EPT found in the endoplasmic reticulum, and such shuttling would bring production of the CDP-ethanolamine into proximity to the EPT. The translocation of ECT between the two organelles could be regulated by a number of factors such as the PE content of the membranes, phosphorylation of the protein, diacylglycerol level of the cells, oxidation-reduction status of the mitochondria, etc. At present, however, no evidence is available for any of these possibilities.

This study has provided information for elucidating the gene structure, function and regulation of two enzymes of the CDP-ethanolamine pathway in *C. reinhardtii*, ECT and EPT. The results obtained here will allow further investigations on the regulatory

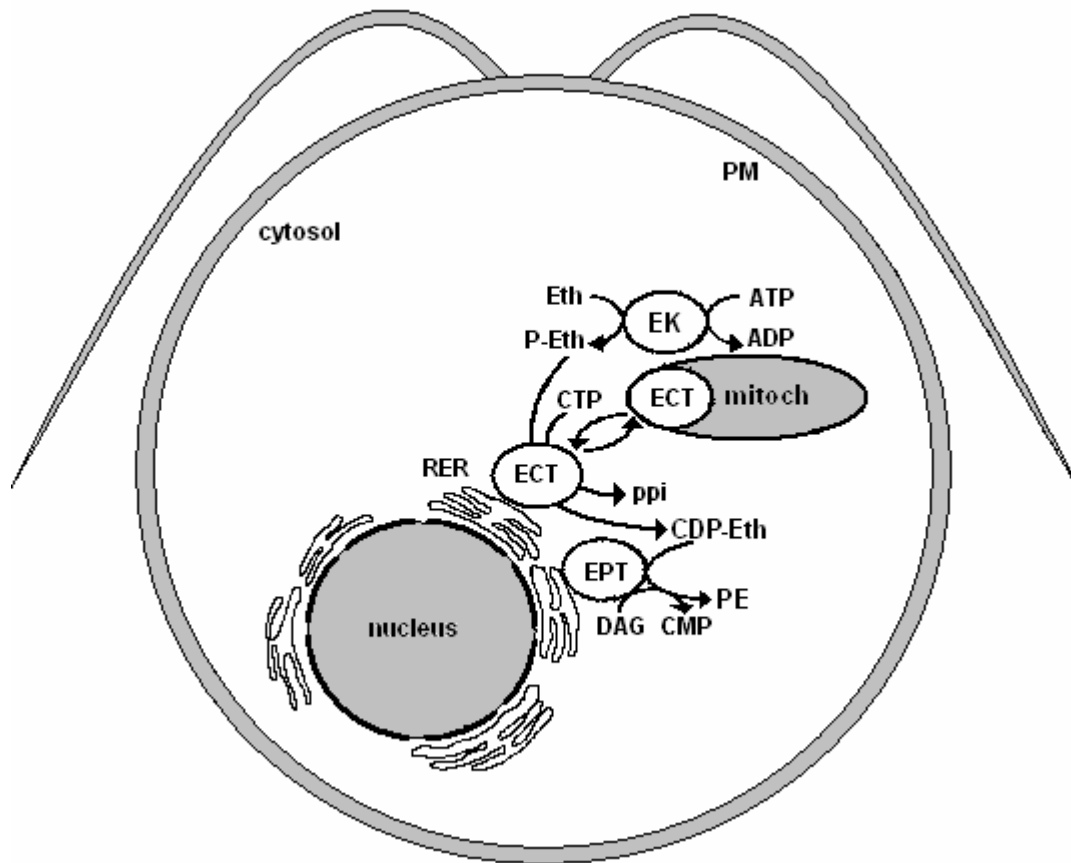

Figure 4.2 A working model for a translocation mechanism of ECT within *C. reinhardtii* cells. Eth, ethanolamine; P-Eth, phosphoethanolamine; CDP-Eth, CDP-ethanolamine; PE, phosphatidylethanolamine; DAG, diacylglycerol; ppi, pyrophosphate; EK, ethanolamine kinase; ECT, CTP: phosphoethanolamine cytidylyltransferase; EPT, ethanolaminephosphotransferase; PM, plasma membrane; RER, rough endoplasmic reticulum; mitoch, mitochondria.

mechanisms for the two enzymes and contribute to our understanding of the physiological significance and regulation of the CDP-ethanolamine pathway in both PC and PE biosynthesis in plants and animals during growth and development.

REFERENCES

- Achleitner G, Zweytick D, Trotter PJ, Voelker DR, Daum G** (1995) Synthesis and intracellular support of aminoglycerophospholipids in permeabilized cells of the yeast *Saccharomyces cerevisiae*. *J Biol Chem* **270**: 29836-29842
- Altschul SF, Gish W, Miller W, Myers EW, Lipman DJ** (1990) Basic local alignment search tool. *J Mol Biol* **215**: 403-410
- Aoyama C, Ohtani A, Ishidate K** (2002) Expression and characterization of the active molecular forms of choline/ethanolamine kinase-alpha and -beta in mouse tissues, including carbon tetrachloride-induced liver. *Biochem J* **363**: 777-784
- Bannai H, Tamada Y, Maruyama O, Nakai K, Miyano S** (2002) Extensive feature detection of N-terminal protein sorting signals. *Bioinformatics* **18**: 298-305
- Becker DM, Fikes JD, Guarente L** (1991) A cDNA encoding a human CCAAT-binding protein cloned by functional complementation in yeast. *Proc Natl Acad Sci USA* **88**: 1968-1972
- Bell RM, Coleman RA** (1980) Enzymes of glycerolipid synthesis in eukaryotes. *Annu Rev Biochem* **49**: 459-487
- Bradford MM** (1976) A rapid and sensitive method for the quantitation of microgram quantities of protein utilizing the principle of protein-dye binding. *Anal Biochem* **72**: 248-254
- Bladergroen BA, van Golde LM** (1997) CTP:phosphoethanolamine cytidylyltransferase. *Biochim Biophys Acta* **1348**: 91-99
- Bladergroen BA, Geelen MJH, Pulla AC, Declercq PE, van Golde LM** (1998) Channelling of intermediates in the biosynthesis of phosphatidylcholine and phosphatidylethanolamine in mammalian cells. *Biochem J* **334**: 511-517
- Bladergroen BA, Houweling M, Geelen MJ, van Golde LM** (1999) Cloning and expression of CTP:phosphoethanolamine cytidylyltransferase cDNA from rat liver. *Biochem J* **343**:107-114
- Bork P, Holm L, Koonin EV, Sander C** (1995) The cytidylyltransferase superfamily: identification of the nucleotide-binding site and fold prediction. *Proteins* **22**: 259-266
- Boynton JE, Gillham NW, Harris EH, Hosler JP, Johnson AM, Jones AR, Randolph-Anderson BL, Robertson D, Klein TM, Shark KB, et al.** (1988) Chloroplast transformation in *Chlamydomonas* with high velocity

- microprojectiles. *Science* **240**: 1534-1538
- Bradford MM** (1976) A rapid and sensitive method for the quantitation of microgram quantities of protein utilizing the principle of protein-dye binding. *Anal. Biochem* **72**: 248-252
- Brothy PJ, Choy PC, Toone JR, Vance DE** (1977) Choline kinase and ethanolamine kinase are separate, soluble enzymes in rat liver. *Eur J Biochem* **78**: 491-495
- Brown AE, Elovson J** (1974) Isolation and characterization of a novel lipid, 1(3),2-diacylglyceryl-(3)-O-4'-(N,N,N-trimethyl)homoserine, from *Ochromonas danica*. *Biochemistry* **13**: 3476-382
- Chapman KD** (2000) Emerging physiological roles for *N*-acylphosphatidylethanolamine metabolism in plants: signal transduction and membrane protection. *Chem Phys Lipids* **108**: 221-229
- Chapman KD, Moore TS** (1993) Catalytic properties of a newly discovered acyltransferase that synthesizes *N*-acylphosphatidylethanolamine in cotton seed (*Gossypium hirsutum* L.) microsomes. *Plant Physiol* **102**: 761-769
- Cheesbrough TM, Moore TS** (1980) Transverse distribution of phospholipids in organelle membranes from *Ricinus communis* L. var. Hale endosperm. Mitochondria and glyoxysomes. *Plant Physiol* **65**: 1076-1080
- Choi S-B, Lee K-W, Cho S-H** (1997) Cloning of CTP: phosphocholine cytidyltransferase cDNA from *Arabidopsis thaliana*. *Molecules and Cells* **7**: 58-63
- Choi YH, Lee JK, Lee CH, Cho SH** (2000) cDNA cloning and expression of an aminoalcoholphosphotransferase isoform in Chinese cabbage. *Plant Cell Physiol* **40**: 1080-1084
- Choi YH, Lee JK, Cho SH** (2001) Structure and expression of a CTP: phosphocholine cytidyltransferase gene from *Arabidopsis thaliana*. *Molecules and Cells* **11**: 95-99
- Chou PY, Fasman GD** (1978) Prediction of the secondary structure of proteins from their amino acid sequence. *Adv Enzymol* **47**: 45-148
- Chow M, Newman JF, Filman D, Hogle JM, Rowlands DJ, Brown F** (1987) Myristylation of picornavirus capsid protein VP4 and its structural significance. *Nature* **327**: 482-486
- Cleland WW** (1970) Steady state kinetics. In PD Boyer, ed, *The Enzymes*. 3rd ed, Vol II, Academic Press, New York, pp 1-65

- Clement JM, Kent C** (1999) CTP:phosphocholine cytidyltransferase: insights into regulatory mechanisms and novel functions. *Biochem Biophys Res Commun* **257**: 643-50
- Coleman R, Bell RM** (1977) Phospholipid synthesis in isolated fat cells. *J Biol Chem* **252**: 3050-3056
- Coleman R, Bell RM** (1978) Evidence that biosynthesis of phosphatidylethanolamine, phosphatidylcholine, and triacylglycerol occurs on the cytoplasmic side of microsomal vesicles. *J Cell Biol* **76**: 245-253
- Cornell RB, Northwood IC** (2000) Regulation of CTP: phosphocholine cytidyltransferase by amphitropism and relocalization. *Trends Biochem Sci* **25**: 441-447
- Craig L, Johnson JE, Cornell RB** (1994) Identification of the membrane-binding domain of rat liver CTP: phosphocholine cytidyltransferase using chymotrypsin proteolysis. *J Biol Chem* **269**: 311-3317
- Cui Z, Shen YJ, Vance DE** (1997) Inverse correlation between expression of phosphatidylethanolamine N-methyltransferase-2 and growth rate of perinatal rat livers. *Biochem Biophys Acta* **1346**: 10-16
- Datko AH, Mudd SH** (1988a) Phosphatidylcholine synthesis: Differing patterns in soybean and carrot. *Plant Physiol* **88**: 854-861
- Datko AH, Mudd SH** (1988b) Enzymes of phosphatidylcholine synthesis in *Lemna*, soybean and carrot. *Plant Physiol* **88**: 1338-1348
- Delarue M, Moras D** (1993) The aminoacyl-tRNA synthetase family: modules at work. *BioEssays* **15**: 675-687
- Dembitsky VM** (1993) Lipids of bryophytes. *Prog Lipid Res* **32**: 281-356
- Devane WA, Hanus L, Breuer A, Pertwee RG, Stevenson LA, Griffin G, Gibson D, Mandelbaum A, Etinger A, Mechoulam R** (1992) Isolation and structure of a brain constituent that binds to the cannabinoid receptor. *Science* **258**: 1946-1949
- Dewey RE, Wilson RF, Novitzky WP, Goode JH** (1994) The AAPT1 gene of soybean complements a cholinephosphotransferase-deficient mutant of yeast. *Plant Cell* **6**: 1495-1507
- Dobrosotskaya IY, Seegmiller AC, Brown MS, Goldstein JL, Rawson RB** (2002) Regulation of SREBP processing and membrane lipid production by phospholipids in *Drosophila*. *Science* **296**: 879-883

- Draus ED, Niefind J, Victor K, Havsteen B** (1990) Isolation and characterization of the human liver ethanolamine kinase. *Biochim Biophys Acta* **1045**: 195-204
- Dunahay TG** (1993) Transformation of *Chlamydomonas reinhardtii* with silicon carbide whiskers. *BioTechniques* **15**: 452-460
- Dykes CW, Kay J, Harwood JL** (1976) Incorporation of choline and ethanolamine into phospholipids in germinating soyabean. *Biochem J* **158**: 575-581
- Eichenberger W** (1976) Lipids of *Chlamydomonas reinhardtii* under different growth conditions. *Phytochemistry* **15**: 459-463
- Eichenberger W** (1993) Betaine lipids in lower plants: distribution of DGTS, DGTA and phospholipids, and the intracellular localization and site of biosynthesis of DGTS. *Plant Physiol Biochem* **31**: 213-221
- Emanuelsson O, Nielsen H, Brunak S, von Heijne G** (2000) Predicting subcellular localization of proteins based on their N-terminal amino acid sequence. *J Mol Biol* **300**: 1005-1016.
- Florini JR, Vestling CS** (1957) Graphical determination of the dissociation constants for two-substrate enzyme systems. *Biochim Biophys Acta* **25**: 575-578
- Garbay B, Cassagne C** (1994) Expression of the ceramide galactosyltransferase gene during myelination of the mouse nervous system. Comparison with the genes encoding myelin basic proteins, choline kinase and CTP:phosphocholine cytidyltransferase. *Brain Res Dev Brain Res* **83**: 119-124
- Garrett TP, Clingeffer DJ, Guss JM, Rogers SJ, Freeman HC** (1984) The crystal structure of poplar apoplastocyanin at 1.8-Å resolution. The geometry of the copper-binding site is created by the polypeptide. *J Biol Chem* **259**: 2822-2825
- Gibson S, Falcone DL, Browse J, Sommerville CR** (1994) Use of transgenic plants and mutants to study the regulation and function of lipid composition. *Plant Cell Environ* **17**: 627-637
- Gietz D, St. Jean A, Woods RA, Schiestl RH** (1992) Improved method for high efficiency transformation of intact yeast cells. *Nucl Acids Res* **20**: 1425
- Giroud C, Gerber A, Eichenberger W** (1988) Lipids of *Chlamydomonas reinhardtii*. Analysis of molecular species and intracellular site(s) of biosynthesis. *Plant Cell Physiol* **29**: 587-595
- Golfman LS, Bakovic M, Vance DE** (2001) Transcription of the CTP: phosphocholine cytidyltransferase alpha gene is enhanced during the S phase of the cell cycle.

J Biol Chem **276**: 43688-43692

- Goode JH, Dewey RE** (1999) Characterization of aminoalcoholphosphotransferases from *Arabidopsis thaliana* and soybean. *Plant Physiol Biochem* **37**: 445-457
- Greenberg ML, Lopes JM** (1996) Genetic regulation of phospholipid biosynthesis in *Saccharomyces cerevisiae*. *Microbiol Rev* **60**: 1-20
- Guthrie C, Fink GR** (1991) Guide to yeast genetics and molecular biology: Methods in Enzymology, Vol. 194. Academic Press, New York
- Harris EH** (1989) The *Chlamydomonas* sourcebook: a comprehensive guide to biology and laboratory use. Academic Press, San Diego, California
- Harris E** (2001) *Chlamydomonas* as a model organism. *Annu Rev Plant Physiol Plant Mol Biol* **52**: 363-406
- Harwood JL** (1976) Synthesis of molecular species of phosphatidylcholine and phosphatidylethanolamine by germinating soya bean. *Phytochem* **15**: 1459-1463
- Harwood JL** (1980) Plant acyl lipids: structure, distribution and analysis. *In* The Biochemistry of Plants, Vol.4, Lipids: Structure and Function. ed, PK Stumpf, Academic Press, New York, pp 1-55
- Henneberry AL, McMaster CR** (1999) Cloning and expression of a human choline/ethanolaminephosphotransferase: synthesis of phosphatidylcholine and phosphatidylethanolamine. *Biochem J* **339**: 291-298
- Hjelmstad RH, Bell RM** (1987) Mutants of *Saccharomyces cerevisiae* defective in *sn*-1,2-diacylglycerol cholinephosphotransferase. Isolation, characterization, and cloning of the *CPT1* gene. *J Biol Chem* **262**: 3909-3917
- Hjelmstad RH, Bell RM** (1988) The *sn*-1,2-diacylglycerol ethanolaminephosphotransferase activity of *Saccharomyces cerevisiae*. Isolation of mutants and cloning of the *EPT1* gene. *J Biol Chem* **263**: 19748-19757
- Hjelmstad RH, Bell RM** (1990) The *sn*-1,2-diacylglycerol cholinephosphotransferase of *Saccharomyces cerevisiae*. Nucleotide sequence, transcriptional mapping, and gene product analysis of the *CPT1* gene. *J Biol Chem* **265**: 1755-1764
- Hjelmstad RH, Bell RM** (1991a) *sn*-1,2-diacylglycerol choline- and ethanolaminephosphotransferases in *Saccharomyces cerevisiae*. Nucleotide sequence of the *EPT1* gene and comparison of the *CPT1* and *EPT1* gene products. *J Biol Chem* **266**: 5094-5103
- Hjelmstad RH, Bell RM** (1991b) *sn*-1,2-diacylglycerol choline- and

- ethanolaminephosphotransferases in *Saccharomyces cerevisiae*. Mixed micellar analysis of the *CPT1* and *EPT1* gene products. *J Biol Chem* **266**: 4357-4365
- Hjelmstad RH, Morash SA, McMaster CR, Bell RM** (1994) Chimeric enzymes: Functional analysis of segments of sn-1,2-diacylglycerol choline- and ethanolamine- phosphotransferases. *J Biol Chem* **269**: 20095-21002
- Hogan M, Kuliszewski M, Lee W, Post M** (1996) Regulation of phosphatidylcholine synthesis in mature type II cells: increased mRNA stability of CTP: phosphocholine cytidyltransferase. *Biochem J* **314**: 799-803
- Horton P, Nakai K** (1997) Better prediction of protein cellular localization sites with the *k* nearest neighbors classifier. *Proc Int Conf Intell Syst Mol Biol* **5**: 147-152
- Hosaka K, Kodaki T, Yamashita S** (1989) Cloning and characterization of the yeast CKI gene encoding choline kinase and its expression in *Escherichia coli*. *J Biol Chem* **264**: 2053-2059
- Hosaka K, Tanaka S, Nikawa J, Yamashita S** (1992) Cloning of a human choline kinase cDNA by complementation of the yeast cki mutation. *FEBS Lett* **304**: 229-232
- Hubscher G, Dils RR, Pover WFR** (1959) Studies on the biosynthesis of phosphatidylserine. *Biochem Biophys Acta* **36**: 518-528
- Houweling M, Tijburg LBM, Vaartjes WJ, Batenburg JJ, Kalmar GB, Cornell RB, Van Golde LMG** (1993) Evidence that CTP: choline-phosphate cytidyltransferase is regulated at a pretranslational level in rat liver after partial hepatectomy. *Eur J Biochem* **214**: 927-933
- Igal RA, Coleman RA** (1996) Acylglycerol recycling from triacylglycerol to phospholipids, not lipase activity, is defective in neutral lipid storage disease fibroblasts. *J Biol Chem* **271**: 16644-16651
- Imhof I, Canivenc-Gansel E, Meyer U, Conzelmann A** (2000) Phosphatidylethanolamine is the donor of the phosphorylethanolamine linked to the α 1, 4-linked mannose of yeast GPI structures. *Glycobiol* **10**: 1271-1275
- Infante JP** (1977) Rate-limiting steps in the cytidine pathway for the synthesis of phosphatidylcholine and phosphatidylethanolamine. *Biochem J* **167**: 847-849
- Ishidate K** (1989) Choline transport and choline kinase. *In* DE Vance, ed, *Phosphatidylcholine Metabolism*. CRC Press, Boca Raton, FL, pp 9-32
- Ishidate K** (1997) Choline/ethanolamine kinase from mammalian tissues. *Biochim Biophys Acta* **1348**: 70-78

- Ishidate K, Iida K, Tadokoro K, Nakazawa Y** (1985) Evidence for the existence of multiple forms of choline (ethanolamine) kinase in rat tissues. *Biochim Biophys Acta* **833**: 1-8
- Ishidate K, Nakazawa Y** (1992) Choline/ethanolamine kinase from rat kidney. *Methods Enzymol* **209**: 121-134
- Jackowski S** (1994) Coordination of membrane phospholipid synthesis with the cell cycle. *J Biol Chem* **269**: 3858-3867
- Jamil H, Utal AK, Vance DE** (1992) Evidence that cyclic AMP-induced inhibition of phosphatidylcholine biosynthesis is caused by a decrease in cellular diacylglycerol levels in cultured rat hepatocytes. *J Biol Chem* **267**: 1752-1760
- Janero DR, Barnett R** (1981a) Cellular and thylakoid membrane glycolipids of *Chlamydomonas reinhardtii* 137⁺. *J Lipid Res* **22**: 1119-1125
- Janero DR, Barnett R** (1981b) Cellular and thylakoid membrane phospholipids of *Chlamydomonas reinhardtii* 137⁺. *J Lipid Res* **22**: 1126-1130
- Janero DR, Barnett R** (1981c) Thylakoid membrane biogenesis in *Chlamydomonas reinhardtii* 137⁺: I. Cell cycle variations in the synthesis and assembly of polar glycerol-lipid. *J Cell Biol* **91**: 126-134
- Janero DR, Barnett R** (1982a) Thylakoid membrane biogenesis in *Chlamydomonas reinhardtii* 137⁺: II. Cell cycle variations in the synthesis and assembly of pigment. *J Cell Biol* **93**: 411-416
- Janero DR, Barnett R** (1982b) Membrane biogenesis in *Chlamydomonas reinhardtii* 137⁺. Cell-cycle variations in the synthesis of phospholipids of non-photosynthetic membranes. *Exp Cell Res* **138**: 451-453
- Jones PL, Willey DL, Gacesa P, Harwood JL** (1998) Isolation, characterisation and expression of a cDNA for pea cholinephosphate cytidyltransferase. *Plant Mol Biol* **37**: 179-185
- Justin AM, Demandre C, Tremoliers A, Mazliak P** (1985) No discrimination by choline- and ethanolaminephosphotransferases from potato tuber microsomes in molecular species of endogenous diacylglycerols. *Biochim Biophys Acta* **836**: 1-7
- Kalmar GB, Kay RJ, Lachance A, Aebersold R, Cornell RB** (1990) Cloning and expression of rat liver CTP: phosphocholine cytidyltransferase: an amphipathic protein that controls phosphatidylcholine synthesis. *Proc Natl Acad Sci USA* **87**: 6029-6033

- Kalmar GB, Kay RJ, LaChance AC, Cornell RB** (1994) Primary structure and expression of a human CTP: phosphocholine cytidylyltransferase. *Biochim Biophys Acta* **1219**: 328-334
- Kato M, Sakai S, Adachi K, Ikemoto H, Sano H** (1996) Distribution of betaine lipids in marine algae. *Phytochemistry* **42**: 1341-1345
- Kennedy EP, Weiss SB** (1956) The function of cytidine coenzyme in the biosynthesis of phospholipids. *J Biol Chem* **222**: 193-214
- Kent C** (1990) Regulation of phosphatidylcholine biosynthesis. *Prog Lipid Res* **29**: 87-105
- Kent C** (1995) Eukaryotic phospholipids biosynthesis. *Annu Rev Biochem* **64**:315-343
- Kent C** (1997) CTP: phosphocholine cytidylyltransferase. *Biochim Biophys Acta* **1348**: 79-90
- Kim K, Kim KH, Storey MK, Voelker DR, Carman GM** (1999) Isolation and characterization of the *Saccharomyces cerevisiae* EKI1 gene encoding ethanolamine kinase. *J Biol Chem* **274**: 14857-14866
- Kindle KL** (1990) High-frequency nuclear transformation of *Chlamydomonas reinhardtii*. *Proc Natl Acad Sci USA* **87**:1228-1232
- Kodaki T, Yamashita S, Nikawa JI** (1987) Primary structure and disruption of the phosphatidylinositol synthase gene of *Saccharomyces cerevisiae*. *J Biol Chem* **262**: 4876-4881
- Kyte J, Doolittle RF** (1982) A simple method for displaying the hydrophobic character of a protein. *J Mol Biol* **157**: 105-132
- Lord JM** (1975) Evidence that phosphatidylcholine and phosphatidylethanolamine are synthesized by a single enzyme present in the endoplasmic reticulum of castor bean endosperm. *Biochem J* **151**: 451-453
- Letunic I, Copley RR, Schmidt S, Ciccarelli FD, Doerks T, Schultz J, Ponting CP, Bork P** (2004) SMART 4.0: towards genomic data integration. *Nucleic Acids Research* **32**: Database issue D142-D144
- Lykidis A, Wang J, Karim MA, Jackowski S** (2001) Overexpression of a mammalian ethanolamine-specific kinase accelerates the CDP-ethanolamine pathway. *J Biol Chem* **276**:2174-2179
- Macher BA, Mudd JB** (1974) Biosynthesis of phosphatidylethanolamine are

- synthesized by enzyme preparations from plant tissues. *Plant Physiol* **53**: 171-175
- Macher BA, Mudd JB** (1976) Partial purification and properties of ethanolamine kinase from spinach leaf. *Arch Biochem Biophys* **177**: 24-30
- MacDonald JJ, Kent C** (1994) Identification of phosphorylation sites in rat liver CTP: phosphocholine cytidyltransferase. *J Biol Chem* **269**: 10529-10537
- Mancini A, Roberti R, Binaglia L, el Missiri A, Freysz L** (1993) Factors affecting the stability of detergent-solubilized cholinephosphotransferase and ethanolaminephosphotransferase. *Membrane Biochem* **10**: 43-52
- McGee TP, Skinner HB, Bankaitis VA** (1994) Functional redundancy of the CDP-ethanolamine and CDP-choline pathway enzymes in phospholipids synthesis: Ethanolamine dependent effects on steady-state membrane phospholipids composition in *saccharomyces cerevisiae*. *J bacterial* **176**: 6861-6868
- McMaster CR, Bell RM** (1994) Phosphatidylcholine biosynthesis in *Saccharomyces cerevisiae*: Regulatory insights from studies employing null and chimeric *sn-1*, 2-diacylglycerol choline- and ethanolaminephosphotransferases. *J Biol Chem* **269**: 28010-28016
- McMaster CR, Bell RM** (1997) CDP-ethanolamine:1,2-diacylglycerol ethanolaminephosphotransferase. *Biochim Biophys Acta* **1348**: 117-123
- McMaster CR, Choy PC** (1992) Newly imported ethanolamine is preferentially utilized for phosphatidylethanolamine biosynthesis in the hamster heart. *Biochim Biophys Acta* **1124**: 13-16
- McMaster CR, Morash SC, Bell RM** (1996) Phospholipid and cation activation of chimeric choline/ethanolamine phosphotransferases. *Biochem J* **313**: 729-735
- McMaster CR, Tardi PG, Choy PC** (1992) Modulation of phosphatidylethanolamine biosynthesis by exogenous ethanolamine and analogues in the hamster heart. *Mol Cell Biochem* **116**: 69-73.
- Menon AK, Stevens VL** (1992) Phosphatidylethanolamine is the donor of the ethanolamine residue linking a glycosylphosphatidylinositol anchor to protein. *J Biol Chem* **267**: 15277-15280
- Min-Seok R, Kawamata Y, Nakamura H, Ohta A, Takagi M** (1996) Isolation and characterization of ECT1 gene encoding CTP:phosphoethanolamine cytidyltransferase of *Saccharomyces cerevisiae*. *J Biochem* **120**:1040-1047
- Min KM, Bae YG, Lee JS, Choi YH, Cha YR, Cho SH** (1997) Cloning of an aminoalcoholphosphotransferase cDNA from Chinese cabbage roots. *J Plant Biol*

40: 234-239

- Menon AK, Stevens VL** (1992) Phosphatidylethanolamine is the donor of the ethanolamine residue linking a glycosylphosphatidylinositol anchor to protein. *J Biol Chem* **267**: 15277-15280
- Monks DE, Goode JH, Dewey RE** (1996) Characterization of soybean choline kinase cDNAs and their expression in yeast and *Escherichia coli*. *Plant Physiol* **110**:1197-1205
- Moore TS** (1976) Phosphatidylcholine synthesis in castor bean endosperm. *Plant Physiol* **57**: 383-386
- Moore TS** (1982) Phospholipid biosynthesis. *Ann Rev Plant Physiol* **33**: 235-259
- Moore TS** (1990) Enzymes of phospholipids synthesis. *In* PJ Lea, ed, *Methods in Plant Biochemistry*, Vol 3: Enzymes of Primary Metabolism. Academic Press, London, pp 229-239
- Moore TS** (1993) *Lipid metabolism in plants*. CRC Press, Boca Raton, FL.
- Moore TS, Du ZR, Chen Z** (2001) Membrane lipid biosynthesis in *Chlamydomonas reinhardtii*. In vitro biosynthesis of diacylglyceryltrimethylhomoserine. *Plant Physiol* **125**: 423-429
- Morand JN, Kent C** (1989) Localization of the membrane-associated CTP: phosphocholine cytidyltransferase in Chinese hamster ovary cells with an altered membrane composition. *J Biol Chem* **264**: 13785-13792
- Morash SC, McMaster CR, Hjelmstad RH, Bell RM** (1994) Studies employing *Saccharomyces cerevisiae cpt1* and *ept1* null mutants implicate the *CPT1* gene in coordinate regulation of phospholipids biosynthesis. *J Biol Chem* **269**: 28769-28776
- Moyano E, Ramazanov Z, Cardenas J, Munoz-Blanco J** (1992) Intracellular localization of three L-glutamate dehydrogenase isozymes from *Chlamydomonas reinhardtii*. *Plant Physiol* **100**: 1575-1579
- Mukherjee JJ, Chung T, Ways DK, Kiss Z** (1996) Protein kinase C α is a major mediator of the stimulatory effect of phorbol ester on phospholipase D-mediated hydrolysis of phosphatidylethanolamine. *J Biol Chem* **271**: 28912-28917
- Murata N, Sommerville CR** (1993) *Biochemistry and Molecular Biology of Membrane and Storage Lipids of Plants*. American Society of Plant Physiologists, Rockville, MD.

- Nakashima A, Hosaka K, Nikawa JI** (1997) Cloning of a human cDNA for CTP-phosphoethanolamine cytidyltransferase by complementation in vivo of a yeast mutant. *J Biol Chem* **272**: 9567-9572
- Nikawa J, Yonemura K, Yamashita S** (1983) Yeast mutant with thermolabile CDP-choline synthesis. Isolation and characterization of a cholinephosphate cytidyltransferase mutant. *Eur J Biochem* **131**: 223-229
- Nishida I, Swinhoe R, Slabas AR, Murata N** (1996) Cloning of *Brassica napus* CTP: phosphocholine cytidyltransferase cDNAs by complementation in a yeast *cct* mutant. *Plant Mol Biol* **31**: 205-211
- O KM, Siow YL, Choy PC** (1989) Hamster liver cholinephosphotransferase and ethanolaminephosphotransferase are separate enzymes. *Biochem Cell Biol* **67**: 680-686
- Pavlidis P, Ramaswami M, Tanouye MA** (1994) The *Drosophila* easily shocked gene: A mutation in a phospholipid synthetic pathway causes seizure, neuronal failure, and paralysis. *Cell* **79**: 23-33
- Park YS, Gee P, Sanker S, Schurler EJ, Zuidenweg EB, Kent C** (1997) Identification of functional conserved residues of CTP: glycerol-3-phosphate cytidyltransferase: Role of histidines in the conserved HXGH in catalysis. *J Biol Chem* **272**: 15161-15166
- Percy AK, Carson MA, Moore JF, Waechter CJ** (1984) Control of phosphatidylethanolamine metabolism in yeast: diacylglycerol ethanolaminephosphotransferase and diacylglycerol cholinephosphotransferase are separate enzymes. *Arch Biochem Biophys* **230**: 69-81
- Polokoff MA, Wing DC, Raetz CR** (1981) Isolation of somatic cell mutants defective in the biosynthesis of phosphatidylethanolamine. *J Biol Chem* **256**: 7687-7690
- Porter TJ, Kent C** (1990) Purification and characterization of choline/ethanolamine kinase from rat liver. *J Biol Chem* **265**: 414-422
- Porter TJ, Kent C** (1992) Choline/ethanolamine kinase from rat liver. *Methods Enzymol* **209**: 134-146
- Prud'homme MP, Moore TS** (1992) Phosphatidylcholine synthesis in castor bean endosperm: Free base as intermediates. *Plant Physiol* **100**: 1527-1535
- Qi Q, Huang YF, Cutler AJ, Abrams SR, Taylor DC** (2003) Molecular and biochemical characterization of an aminoalcoholphosphotransferase (AAPT1) from *Brassica napus*: effects of low temperature and abscisic acid treatments on AAPT expression in *Arabidopsis* plants and effects of over-expression of

- BnAAPT1 in transgenic *Arabidopsis*. *Planta* **217**: 547-558
- Rochaix JD** (1978) Restriction endonuclease map of the chloroplast DNA of *Chlamydomonas reinhardtii*. *J Mol Biol* **126**: 597-617
- Rochaix JD** (1995) *Chlamydomonas reinhardtii* as the photosynthetic yeast. *Annu Rev Genet* **29**: 209-230
- Rutherford MS, Rock CO, Jenkins NA, Gilbert DJ, Tessner TG, Copeland NG, Jackowski S** (1993) The gene for murine CTP: phosphocholine cytidyltransferase (Ctpct) is located on murine chromosome 16. *Genomics* **18**: 698-701
- Sambrook J, Fritsch EF, Maniatis T** (1989) *Molecular Cloning: A Laboratory Manual*. Cold Spring Harbor Laboratory Press, Cold Spring Harbor, New York
- Sato N** (1988) Dual role of methionine in the biosynthesis of diacylglyceryltrimethylhomoserine in *Chlamydomonas reinhardtii*. *Plant Physiol* **86**: 931-934
- Sato N, Furuya M** (1985) Distribution of diacylglyceryltrimethylhomoserine and phosphatylcholine in nonvascular green plants. *Plant Sci* **38**: 81-85
- Sato N, Kato K** (1988) Analysis and biosynthesis of diacylglyceryl-*N,N,N*-trimethylhomoserine in the cells of *Marchantia* in suspension culture. *Plant Sci* **55**: 21-25
- Schmid HHO, Schmid PC, Natarajan V** (1990) *N*-acylated glycerolphospholipids and their derivatives. *Prog Lipid Res* **29**: 1-43
- Sesca E, Perletti GP, Binasco V, Chiara M, Tessitore L** (1996) Phosphatidylethanolamine *N*-methyltransferase 2 and CTP-phosphocholine cytidyltransferase expressions are related with protein kinase C isozymes in developmental liver growth. *Biochem Biophys Res Commun* **229**: 158-162
- Shiao YJ, Vance JE** (1995) Evidence for an ethanolamine cycle: differential recycling of the ethanolamine moiety of phosphatidylethanolamine derived from phosphatidylserine and ethanolamine. *Biochem J* **310**: 673-679
- Shimogawara K, Fujiwara S, Grossman A, Usuda H** (1998) High-efficient transformation of *Chlamydomonas reinhardtii* by electroporation. *Genetics* **148**: 1821-1828
- Shin SH, Moore TS** (1990) Phosphatidylethanolamine synthesis by castor bean endosperm - a base exchange reaction. *Plant Physiol* **93**: 148-153

- Shin SH, Moore TS** (1990) Phosphatidylethanolamine synthesis by castor bean endosperm – membrane bilayer distribution of phosphatidylethanolamine synthesized by the ethanolaminephosphotransferase and ethanolamine exchange reactions. *Plant Physiol* **93**: 154-159
- Silflow C** (1998) Organization of the nuclear genome. *In* Rochaix JD, Goldschmidt-Clement M, Merchant S, (eds), *The Molecular Biology of Chloroplasts and Mitochondria in Chlamydomonas*. Dordrecht, Kluwer Academic Publishers, the Netherlands. pp 25-40
- Slabas AR, Fawcett T** (1992) The biochemistry and molecular biology of plant lipid biosynthesis. *Plant Mol Biol* **19**: 169-191
- Sparace SA, Wagner LK, Moore TS** (1981) Phosphatidylethanolamine synthesis in castor bean endosperm. *Plant Physiol* **67**: 922-925
- Spiegel S, Merrill AH** (1996) Sphingolipid metabolism and cell growth regulation. *FASEB J* **10**: 1388-1397
- Spreitzer RJ, Al-Abad SR, Huether MJ** (1988) Temperature-sensitive, photosynthesis-deficient mutants of *Chlamydomonas reinhardtii*. *Plant Physiol* **86**: 773-777
- Sundler R** (1973) Biosynthesis of rat liver phosphatidylethanolamines from intraportally injected ethanolamine. *Biochim Biophys Acta* **306**: 218-226
- Sundler R** (1975) Ethanolaminephosphate cytidyltransferase. Purification and characterization of the enzyme from rat liver. *J Biol Chem* **250**: 8585-8590
- Sundler R, Akesson B** (1975) Regulation of phospholipid biosynthesis in isolated rat hepatocytes. Effect of different substrates. *J Biol Chem* **250**: 3359-3367
- Sundler R, Akesson B, Nilsson A** (1974) Quantitative role of base exchange in phosphatidylethanolamine synthesis in isolated rat hepatocytes. *FEBS Lett* **43**: 303-307
- Sweitzer TD, Kent C** (1994) Expression of wild-type and mutant rat liver CTP: phosphocholine cytidyltransferase-deficient Chinese hamster ovary cell line. *Arch Biochem Biophys* **311**: 107-116
- Tang FQ, Moore TS** (1997) Enzymes of the primary phosphatidylethanolamine biosynthesis pathway in postgermination castor bean endosperm. *Plant Physiol* **115**: 1589-1597
- Tessner TG, Rock CO, Kalmar GB, Cornell RB, Jackowski S** (1991) Colony-stimulating factor 1 regulates CTP: phosphocholine cytidyltransferase mRNA levels. *J Biol Chem* **266**: 16261-16264

- Thompson RJ, Mosig G** (1984) Light and genetic-determinants in the control of specific chloroplast transcripts in *Chlamydomonas reinhardtii*. *Plant Physiol* **76**: 1-6
- Tijburg LB, Houweling M, Geelen MJ, van Golde LM** (1987) Stimulation of phosphatidylethanolamine synthesis in isolated rat hepatocytes by phorbol 12-myristate 13-acetate. *Biochim Biophys Acta* **922**: 184-190
- Tijburg LB, Houweling M, Geelen MJ, van Golde LM** (1988) Effects of dietary conditions on the pool sizes of precursors of phosphatidylcholine and phosphatidylethanolamine synthesis in rat liver. *Biochim Biophys Acta* **959**: 1-8
- Tijburg LB, Geelen MJ, van Golde LM** (1989a) Regulation of the biosynthesis of triacylglycerol, phosphatidylcholine and phosphatidylethanolamine in the liver. *Biochim Biophys Acta* **1004**:1-19
- Tijburg LB, Houweling M, Geelen MJ, van Golde LM** (1989b) Inhibition of phosphatidylethanolamine synthesis by glucagons in isolated rat hepatocytes. *Biochem J* **257**: 645-650
- Towler DA, Gordon JI, Adams SP, Glaser L** (1988) The biology and enzymology of eukaryotic protein acylation. *Annu Rev Biochem* **57**: 69-99
- Trewavas A, Gilroy S** (1991) Signal transduction in plant cells. *Trends in Genetics* **7**: 356-361
- Tsukagoshi Y, Nikawa J, Yamashita S** (1987) Molecular cloning and characterization of the gene encoding cholinephosphate cytidyltransferase in *Saccharomyces cerevisiae*. *Eur J Biochem* **169**: 477-486
- Uchida T** (1994) Regulation of choline kinase R: Analysis of alternatively spliced choline kinases and the promoter region. *J Biochem* **116**: 508-518
- Uchida T** (1997) A novel high-molecular mass mammalian ethanolamine kinase. *Biochim Biophys Acta* **1349**: 13-24
- Uchida T, Yamashita S** (1992a) Choline/ethanolamine kinase from rat brain. *Methods Enzymol* **209**: 147-153
- Uchida T, Yamashita S** (1992b) Molecular cloning, characterization, and expression in *Escherichia coli* of a cDNA encoding mammalian choline kinase. *J Biol Chem* **267**: 10156-10162
- Umeda M, Emoto K** (1999) Membrane phospholipid dynamics during cytokinesis: regulation of actin filament assembly by redistribution of membrane surface phospholipids. *Chem Phys Lipids* **101**: 81-91

- Vance JE** (2003) Molecular and cell biology of phosphatidylserine and phosphatidylethanolamine metabolism. *Prog Nucleic Acid Res Mol Biol* **75**: 69-111
- Vance DE** (1996) Glycerolipid biosynthesis in eukaryotes, *In* DE Vance, JE Vance, eds, *Biochemistry of Lipids, Lipoproteins and Membranes*, Elsevier Science Publishers, Amsterdam, pp 153-182
- Vance DE, Choy PC, Farren SB, Lim P, Schneider W** (1977) Asymmetry of phospholipids biosynthesis. *Nature (London)* **270**: 268-269
- Vance JE, Vance DE** (1988) Does rat liver Golgi have the capacity to synthesize phospholipids for lipoprotein secretion? *J Biol Chem* **263**: 5898-5909
- van Hellemond JJ, Slot JW, Geelen MJ, van Golde LM, Vermeulen PS** (1994) Ultrastructural localization of CTP: phosphoethanolamine cytidyltransferase in rat liver. *J Biol Chem* **269**: 15415-15418
- Veitch DP, Cornell RB** (1996) Substitution of serine for glycine-91 in the HXGH motif of CTP: phosphocholine cytidyltransferase implicates this motif in CTP binding. *Biochemistry* **35**: 10743-10750
- Vermeulen PS, Tijburg LB, Geelen MJ, van Golde LM** (1993) Immunological characterization, lipid dependence, and subcellular localization of CTP: phosphoethanolamine cytidyltransferase purified from rat liver. Comparison with CTP: phosphocholine cytidyltransferase. *J Biol Chem* **268**: 7458-7464
- Vermeulen PS, Geelen MJ, van Golde LM** (1994) Substrate specificity of CTP: phosphoethanolamine cytidyltransferase purified from rat liver. *Biochim Biophys Acta* **1211**: 343-349
- Vermeulen PS, Geelen MJH, Tijburg LBM, van Golde LMG** (1997) The CDP-ethanolamine pathway in mammalian cells. *In* RWGross, ed, *Advances in Lipobiology*, vol. 2. JAI Press, Greenwich, CT, pp 287-322
- Walk RA, Hock B** (1977) Glyoxysomal malate dehydrogenase of watermelon cotyledons: de novo synthesis on cytoplasmic ribosomes. *Planta* **134**: 277-285
- Wang Y, Kent C** (1995) Identification of an inhibitory domain of CTP: phosphocholine cytidyltransferase. *J Biol Chem* **270**: 18948-18952
- Wang XM, Moore TS** (1989) Partial purification and characterization of CTP:cholinephosphate cytidyltransferase from castor bean endosperm. *Arch Biochem Biophys* **274**: 338-347

- Wang XM, Moore TS** (1990) Phosphatidylcholine biosynthesis in castor bean endosperm. Purification and properties of cytidine 5'-triphosphate: choline-phosphate cytidyltransferase. *Plant Physiol* **93**: 250-255
- Wang XM, Moore TS** (1991) Phosphatidylethanolamine synthesis by castor bean endosperm. Intracellular distribution and characteristics of CTP:ethanolaminephosphate cytidyltransferase. *J Biol Chem* **266**: 19981-19987
- Wang Y, Sweitzer TD, Weinhold PA** (1993) Nuclear localization of soluble CTP: phosphocholine cytidyltransferase. *J Biol Chem* **268**: 5899-5904
- Wang Y, MacDonald JI, Kent C** (1995) Identification of the nuclear localization signal of rat liver CTP: phosphocholine cytidyltransferase. *J Biol Chem* **270**: 354-360
- Watkins JD, Kent C** (1992) Immunolization of membrane-associated CTP: phosphocholine cytidyltransferase in phosphatidylcholine-deficient Chinese hamster ovary cells. *J Biol Chem* **267**: 5686-5692
- Weinhold PA, Rethy VB** (1974) The separation, purification, and characterization of ethanolamine kinase and choline kinase from rat liver. *Biochemistry* **13**: 5135-5141
- Weinhold PA, Rounsifer ME, Feldman DA** (1986) The purification and characterization of CTP: phosphorylcholine cytidyltransferase from rat liver. *J Biol Chem* **261**: 5104-5110
- Wharfe J, Harwood JL** (1979) Lipid metabolism in germinating seeds. Purification of ethanolamine kinase from soya bean. *Biochim Biophys Acta* **575**: 102-111
- Wieder T, Geilen CC, Wieprecht M, Becker A, Orfanos CE** (1994) Identification of a putative membrane-interacting domain of CTP: phosphocholine cytidyltransferase from rat liver. *FEBS Letter* **345**: 207-210
- Williams WP** (1994) The role of lipids in the structure and function of photosynthetic membranes. *Prog Lipid Res* **33**: 119-127
- Witman GB, Carlson K, Berlinger J, Rosenbaum JL** (1972) *Chlamydomonas* flagella. I. Isolation and electrophoretic analysis of microtubules, matrix, membranes, and mastigonemes. *J Cell Biol* **54**: 507-539
- Wittenberg J, Kornberg A** (1953) Choline phosphokinase. *J Biol Chem* **202**: 431-444
- Yeo HJ, Sri Widada J, Mercereau-Puijalon O, Vial HJ** (1995) Molecular cloning of CTP: phosphocholine cytidyltransferase from *Plasmodium falciparum*. *Eur J Biochem* **233**: 62-72

Zelinski TA, Choy PC (1982) Phosphatidylethanolamine biosynthesis in the isolated hamster heart. Can J Biochem 60: 817-823

**APPENDIX: RELATED EST CLONES AND GENES OF ECT AND EPT
IN DATABASE**

Table A1 EST clones obtained from searching the *C. reinhardtii* EST database using the CTP: phosphoethanolamine cytidyltransferase (ECT) protein sequences of *H. sapiens* and *R. norvegicus*.

Contig 1		Contig 2	
GenBank accession number	Clone number	GenBank accession number	Clone number
BI721203	1031054F02.y1	BE441446	925006A04.y1
BI997738	1031051F03.y2	BI998082	1031054F02.x2
BI720717	1031051F03.y1	BI728950	1031102E12.x1
BI728951	1031102E12.y1	BI997737	1031051F03.x2
BI718796	1031031E02.y1	BE441445	925006A04.x1
		BI995895	1031031E02.x2
		BI721202	1031054F02.x1
5' UTR and partial coding: 175 a.a start codon : ATG		3' UTR and partial coding: 135 a.a stop codon: TGA	

Table A2 The accession numbers of nucleotide and protein sequences of aminoalcoholphosphotransferase (EPT) genes of various organisms in GenBank.

Organism	Gene Name	cDNA	Protein
<i>C. reinhardtii</i>	<i>EPT</i>	AY375472	AAQ83686
<i>H. sapiens</i>	<i>CPT/EPT</i>	AF068302	AAD25170
<i>M. musculus</i>	<i>CPT/EPT</i>	BC021753	AAH21753
<i>S. cerevisiae</i>	<i>CPT1</i>	J05203	AAA63571
<i>S. cerevisiae</i>	<i>EPT1</i>	M59331	AAA63572
<i>A. thaliana</i>	<i>AtAAPT1</i>	AF091843	AAC61768
<i>A. thaliana</i>	<i>AtAAPT2</i>	AF091844	AAC61769
<i>B. rapa</i>	<i>AAPT1</i>	U96713	AAB53764
<i>G. max</i>	<i>AAPT1</i>	U12735	AAA67719

Table A3 Summary of the CTP: phosphoethanolamine cytidyltransferase (ECT) gene structure in the *C. reinhardtii* genome (GenBank accession number AY266140).

Component	Length (bp)
5' UTR	217
Exons (10)	(2039)
Exon1	346
Exon2	73
Exon3	77
Exon4	142
Exon5	149
Exon6	90
Exon7	228
Exon8	128
Exon9	127
Exon10	679
Introns (9)	(1922)
Intron1	143
Intron2	223
Intron3	204
Intron4	270
Intron5	163
Intron6	419
Intron7	176
Intron8	150
Intron9	174
3' UTR	493
Total	3961

Table A4 Summary of the ethanolaminephosphotransferase (EPT) gene structure in the *C. reinhardtii* genome (GenBank accession number AY375473).

Component	Length (bp)
5' UTR	177
Exons (7)	(1952)
Exon1	283
Exon2	114
Exon3	227
Exon4	193
Exon5	107
Exon6	122
Exon7	906
Introns (6)	(1427)
Intron1	143
Intron2	179
Intron3	312
Intron4	222
Intron5	303
Intron6	268
3' UTR	626
Total	3379

VITA

Wenyu Yang was born on December 24, 1963 in Suihua County, Heilongjiang Province, the People's Republic of China. He entered Red Flag High School in 1977 and finished high school study in 1979. In September, 1979, he was accepted by Heilongjiang August-First Agricultural Land Reclamation University where he studied in the Department of Agronomy with a major in agronomy for four years, and received his Bachelor of Science degree in agronomy in July, 1983. In July, 1986, he was involved in a cooperative program between China and Canada by studying in the Department of Crop Science, University of Guelph in Ontario, Canada, where he received a Master of Science degree in plant physiology in October, 1989. He then worked in the Institute of Botany and Shanghai Institute of Plant Physiology, Chinese Academy of Sciences, in Peking and Shanghai for several years. In January, 2000, he came to Louisiana State University for his doctoral studies. He completed the graduate program toward the degree of Doctor of Philosophy in the Department of Biological Sciences.