

**AN ECOPATH/ECOSIM ANALYSIS OF AN ESTUARINE FOOD WEB:
SEASONAL ENERGY FLOW AND RESPONSE TO
RIVER-FLOW RELATED PERTURBATIONS**

A Thesis

Submitted to the Graduate Faculty of the
Louisiana State University and
Agricultural and Mechanical College
in partial fulfillment of the
requirements for the degree of
Master of Science

in

The Department of Oceanography and Coastal Sciences

by
Laura Lynette Althausen
B.S., Texas A&M University, 1999
May 2003

ACKNOWLEDGEMENTS

I would first like to thank my major professor, Dr. Kenneth A. Rose for his insight, advice, support, and enthusiasm. He is truly an inspiration as a scientist, and without him I would not have made this journey. Dr. James H. Cowan, Jr. provided much of the initial data and many hours of help and support in the creation of this project. He is also a great inspiration as a scientist, and another of the major reasons for my success in this program. This research was supported in part by the National Marine Fisheries Service Laboratory in Galveston, Texas. Dr. Thomas Minello and Dr. Roger Zimmerman were instrumental in my appointment as a cooperative education student, and I thank them for the opportunity and support they provided while I completed this project. Partial funding for this research was supplied by the Electric Power Research Institute, Palo Alto, California.

Without the support of the Rose Lab: Cheryl Murphy, Shaye Sable, and Aaron Adamack, I would surely have been a basket case long before this project was finished. Dr. Matt Slocum provided many hours of discussion and advice that were invaluable. There were many students who were sources of support and encouragement to me while I worked on this project, and I thank them (in no particular order): Sean Keenan, Hongsheng Bi, Ted Switzer, Dr. Frank Hernandez, and Dr. Heather Haas. My "hockey family": Renee, Rob, Sarah, and Robin Capps provided me with a home away from home when I was at my worst, and without them I wouldn't have made it. My family have always been the most important people in my life, and their faith in me kept me going through the hardest of times. Finally, this project is dedicated to the memory of my brother Timothy Paul Althaus, who passed away in early 2002.

TABLE OF CONTENTS

ACKNOWLEDGEMENTS	ii
LIST OF TABLES	iv
LIST OF FIGURES	v
ABSTRACT	viii
1 INTRODUCTION	1
2 METHODS	7
3 RESULTS	29
4 DISCUSSION	81
LITERATURE CITED	93
APPENDIX: ADDITIONAL EQUATIONS	97
VITA	98

LIST OF TABLES

1. Sources of the input parameters of biomass, and the ratios of production to biomass P/B and consumption to biomass Q/B for the four season-specific Ecopath models.....	15
2. Input parameters of biomass, and the ratios of production to biomass P/B and consumption to biomass Q/B for the four season-specific Ecopath models. Biomass is in units of g dw m^{-2} ; P/B and Q/B are in units of quarter^{-1}	16
3. Season-specific Ecopath parameters of biomass and production by categories of groups. Biomass is in units of gdw m^{-2} ; production is in units of $\text{gdw m}^{-2} \text{quarter}^{-1}$	39
4. Average trophic level estimated by Ecopath for each group aggregated into categories by season.....	40
5. Biomass consumption ($\text{gdw m}^{-2} \text{quarter}^{-1}$) by categories of groups as predators and trophic levels as prey for each season.....	41
6. Biomass flows to detritus and biomass imported by categories of groups for each season...42	
7. Utilization (consumption) of detrital biomass ($\text{gdw m}^{-2} \text{quarter}^{-1}$) by categories of groups by season.....	43
8. Higher-order indices of ecosystem development and functioning (throughput, ascendancy, overhead, and capacity) as calculated by Ecopath for each season.....	43
9. Percent change in peak biomass and the numbers of months required for recovery to baseline biomass levels under pulsed high-flow and low-flow years for each of the groups. Percent change in peak biomass was computed as the peak under pulsed minus the peak under baseline divided by the peak under baseline.....	55
10. Long-term average biomass under baseline and under interannual variation simulations, and the percent change from baseline, for each of the groups. Percent change was computed as interannual biomass minus baseline biomass divided by baseline biomass.....	65
11. Average long-term biomass of blue crab, carnivorous fish, piscivorous fish, and marine mammals for the 2×2 factorial simulation experiment with one factor of magnitude (20% or 40%) and the other factor as grouping (alternating or grouped with four high-flow followed by four low-flow years).....	75

LIST OF FIGURES

1. Weeks Bay, Alabama, USA. State map modified from <http://alabamamaps.ua.edu> and location map modified from <http://www.usouthal.edu/geography/baywick/weeksbay.htm>....4
2. Monthly river flow driving variable derived from flow data measured at USGS stream gauge number 02378500 located in the mouth of the Fish River. River flow is the monthly average flow divided by the average annual flow.....22
3. High- and low-flow pulses of river flow in year 10 used in the short-term simulations. Years 10 to 20 are shown. (A) baseline, (B) high-flow pulse in year ten, (C) low-flow pulse in year 10.....25
4. River flow driving variable for the long-term simulations under (A) baseline, (B) within year extremes, and (C) interannual variation conditions. Years 1 to 10 are shown.....27
5. Derived biomass flows among groups for the winter season. Ecopath input parameters of biomass, production, and consumption are given in Table 2.....30
6. Derived biomass flows among groups for the spring season. Ecopath input parameters of biomass, production, and consumption are given in Table 2.....32
7. Derived biomass flows among groups for the summer season. Ecopath input parameters of biomass, production, and consumption are given in Table 2.....34
8. Derived biomass flows among groups for the fall season. Ecopath input parameters of biomass, production, and consumption are given in Table 2.....36
9. Time-series plots of biomass from short term simulations under baseline, high-flow pulse, and low-flow pulse conditions. Pulses were imposed in year 10; years 9 to 20 are shown. (A) phytoplankton, (B) benthic algae, (C) detritus, (D) zooplankton, and (E) zoobenthos.....45
10. Time-series plots of biomass from short-term simulations under baseline, high-flow pulse, and low-flow pulse conditions. Pulses were imposed in year 10; years 9 to 20 are shown. (A) penaeid shrimp, (B) gelatinous zooplankton, and (C) blue crab.....47
11. Time-series plots of biomass from short-term simulations under baseline, high-flow pulse, and low-flow pulse conditions. The pulses were imposed in year 10; years 9 to 20 are shown. (A) anchovy,(B) menhaden, (C) spot, (D) croaker, and (E) mullet.....49
12. Time-series plots from short-term simulations under baseline, high-flow pulse, and low-flow pulse conditions. The pulses were imposed in year 10; years 9 to 20 are shown. (A) marine mammals, (B) benthic fish, (C) piscivorous fish, and (D) carnivorous fish.....51

13. Time-series plots of biomass for the long-term simulations under baseline and within-year extreme flow conditions. Years 75 to 100 are shown. (A) phytoplankton, (B) benthic algae, (C) detritus, (D) zooplankton, and (E) zoobenthos.....	56
14. Time-series plots of biomass for the long-term simulations under baseline and within-year extreme flow conditions. Years 75 to 100 are shown. (A) penaeid shrimp, (B) gelatinous zooplankton, and (C) blue crab.....	58
15. Time-series plots of biomass for the long-term simulations under baseline and within-year extreme flow conditions. (A) anchovy, (B) menhaden, (C) spot, (D) croaker, and (E) mullet.....	60
16. Time-series plots of biomass for the long-term simulations under baseline and within-year extreme flow conditions. Years 75 to 100 are shown. (A) marine mammals, (B) benthic fish, (C) piscivorous fish, and (D) carnivorous fish.....	62
17. Time-series plots of biomass for the long-term simulations under baseline (alternating high- and low-flow years) and interannual variation in river flow (two high-flow followed by four low-flow years) conditions. Years 75 to 100 are shown. (A) phytoplankton, (B) benthic algae, (C) detritus, (D) zooplankton, and (E) zoobenthos.....	66
18. Time-series plots of biomass for the long-term simulations under baseline (alternating high- and low-flow years) and interannual variation in river flow (two high-flow followed by four low-flow years) conditions. Years 75 to 100 are shown. (A) penaeid shrimp, (B) gelatinous zooplankton, and (C) blue crab.....	68
19. Time-series plots of biomass for the long-term simulations under baseline (alternating high- and low-flow and interannual variation in river flow (two high-flow followed by four low-flow years) conditions. Years 75 to 100 are shown. (A) anchovy, (B) menhaden, (C) spot, (D) croaker, and (E) mullet.....	71
20. Time-series plots of biomass for the long-term simulations under baseline (alternating high- and low-flow years) and interannual variation in river flow (two high-flow followed by four low-flow) conditions. Years 75 to 100 are shown. (A) marine mammals, (B) benthic fish, (C) piscivorous fish, and (D) carnivorous fish.....	73
21. Time-series plots of biomass of (A) blue crab, (B) carnivorous fish, (C) piscivorous fish, and (D) marine mammals for long-term simulations with high and low flow defined as 40% changes from baseline river flow for years ungrouped (alternating high- and low-flow years) and grouped (two high-flow followed by four low-flow years). Years 75 to 100 are shown.....	76

22. Time series plots of biomass (A) blue crab, (B) carnivorous fish, (C) piscivorous fish, and (D) marine mammals for long-term simulations with the baseline grouping of years (two high-flow at 20% change from baseline flow followed by four low-flow at 10%) and with a reversed grouping of years (four high-flow at 10% followed by two low-flow at 20%).....78

ABSTRACT

Estuaries are often the receiving basins for major river systems which makes them vulnerable to anthropogenic influences. I used Ecopath and Ecosim to investigate the structure of the Weeks Bay, Alabama, USA food web, and the responses of the food web to bottom-up perturbations. Four season-specific steady-state Ecopath models were developed and used to compare the production, biomass, consumption, biomass flows, and higher order indices of ecosystem functioning of the Weeks Bay food web under winter, spring, summer, and fall conditions. The season-specific Ecopath snapshots indicated that the structure of the Weeks Bay food web was resilient. Winter had the lowest biomass and production and heavy reliance on detritus, leading to high biomass and production in spring and summer, culminating in the most complex food web in fall. Ecosim simulations were performed that examined the responses of the Weeks Bay food web to single pulses of high and low flow years, more extreme seasonal variation of river flow, and interannual variation in river flow (two high-flow years followed by four low-flow years). Baseline simulations produced cyclic behavior at the lowest trophic levels that was gradually dampened as one moved to higher trophic levels of the food web. Lower trophic level groups showed the largest responses and quickest recovery from single pulses of high flow and low flow, while upper trophic level groups showed generally the smallest responses and longest recovery. More extreme within-year variation in river flow caused exaggeration of the seasonal responses predicted under baseline conditions, with little or no change in the average long-term biomass of groups. Interannual variation in high and low flow was mimicked in the biomasses of lower trophic level groups, with some of the upper trophic level groups responding with small, yet consistent, net changes in their long-term average biomass. Additional simulations showed that net changes in biomass were due to the magnitude, number, and temporal arrangement of

high- and low-flow years. Results suggest that changes in nutrient influxes or precipitation patterns can affect the variation and long-term average biomass of key groups of the Weeks Bay food web.

INTRODUCTION

Estuaries are extremely dynamic ecosystems in which environmental fluctuations and changing species compositions are common. Food webs, and the pathways of energy flow within the food web, are temporally variable in estuaries due to changes in river flow, water temperature, water column stratification, salinity gradients, seasonal variation in biota, and ontogenetic changes in feeding strategies of constituent species. In ecosystems dominated by variation, the resilience of the food web depends on how energy flows through the system (Hunter and Price 1992). Many estuarine food webs appear to be highly resilient, as they remain generally intact despite the challenges of an extremely dynamic environment (Day et al. 1989).

Understanding how ecosystems react and recover from perturbations is a fundamental goal of ecology (Cottingham and Schindler 2000). There are two approaches to predicting the dynamics of an ecosystem: experimental and modeling. In ecology, ecosystem-level experiments are frequently unplanned and un-replicable, yet they can yield important insights into the structure, development, and functioning of an ecosystem (Carpenter 1990). Due to their temporal and biological complexity, it is difficult to understand the structure of food webs and trophic interactions by direct observation (Niquil et al. 1999; Schoenly and Cohen 1991).

Ecosystem modeling is an alternative to experimental approaches that can be used to predict ecosystem responses to perturbations and to identify higher-level properties of the ecosystem that are not readily measurable. A potentially powerful study approach is the combination of long-term data sets with ecosystem modeling (Straile 2002). Using long-term data sets from well-studied systems along with computer models can produce useful information and can lead to refinements in ecological theory. Ecosystem models well-grounded with field data allow for the quantification of realistic baseline conditions against which future model predictions can be

compared. This approach assists resource managers and scientists in determining the effects of anthropogenic changes on ecosystems. Using model simulations to characterize the structure and function of an ecosystem and to identify sensitive or critical species can lead to the development of specific research frameworks and monitoring goals, allowing for more efficient management of sensitive ecosystems. Ecosystem models can also be used to quantify the direct and indirect economic benefits of estuaries, which is often needed to evaluate benefits versus costs of various management alternatives. The importance of ecological forecasting via models in the development of regulatory policy is well recognized (Clark et al. 2001).

Many different types of modeling approaches can be used; I will focus on food web and ecosystem models that allow for the modeling of perturbations on several different time scales (e.g., within year, interannual). This allows for exploration of the impact of a wide variety of types of environmental disturbances. By determining where there are energy sources and sinks within an estuarine system, critical ecosystem components can be identified. In addition, ecosystem models allow for the estimation of higher-level indices of ecosystem functioning. Odum's theory of ecosystem structure and function defined characteristics that explain the maturity, stability, and resilience of an ecosystem (Odum 1969). By analyzing the flow of energy within a system, Ulanowicz (1980) elaborated on Odum's original theories, and coupled the concepts to quantitative indices. Ulanowicz (1980) mathematically defined the concepts of capacity, throughput, and ascendancy. These indices help to characterize the properties of food webs by providing an overall elaboration of their structure and function (Niquil et al. 1999).

There are many urgent reasons to improve our understanding of how estuarine ecosystems respond to environmental perturbations. Depleted fish populations (Pauly et al. 2001), global climate change (Kennedy et al. 2002), localized and widespread eutrophication (Micheli 1999),

alteration of natural river flow through flow control structures and levees (Chesney et al. 2000), and invasive species (Clark et al. 2001) are just some examples of the types of perturbations estuarine ecosystems are subjected to in an increasingly populous world. The specific effects of global climate change on estuarine systems are unknown, yet this process is accelerating (Kennedy et al. 2002). Developing models that can predict the direction and magnitude of ecosystem responses to global climate change is an important area of current scientific inquiry that is relevant to almost all ecosystems. Eutrophication due to increased runoff of freshwater that results in increased nutrient loads in coastal waters is a problem of particular importance in the highly developed watersheds along the northern coast of the Gulf of Mexico (McIsaac et al. 2001).

Increased nutrient loading leading to the eutrophication of marine and estuarine ecosystems is one of the major perturbations ultimately caused by increasing human population worldwide (Micheli 1999). Pulses of nutrients delivered by freshwater runoff are a bottom-up perturbation of an estuary. It is therefore important to understand the bottom-up effects of nutrient pulses on estuarine food webs, and the effects of potential changes in the duration and strength of nutrient pulses, in order to effectively manage estuarine ecosystems (Wolff et al. 2000).

I applied the Ecopath and Ecosim models to Weeks Bay, Alabama, USA (Fig. 1), to explore the responses of a shallow, pulse-driven estuarine ecosystem to bottom-up perturbations. Ecopath is a steady-state model that examines energy or biomass flows among food web functional groups. Ecopath allows for identification of key components of the ecosystem, and estimation of higher-order indices such as capacity, throughput, and ascendancy. Ecosim is a dynamic model that simulates the biomass of each species or functional group in the food web over time. Ecosim allows for prediction of time-dependent responses of ecosystems to pulsed or

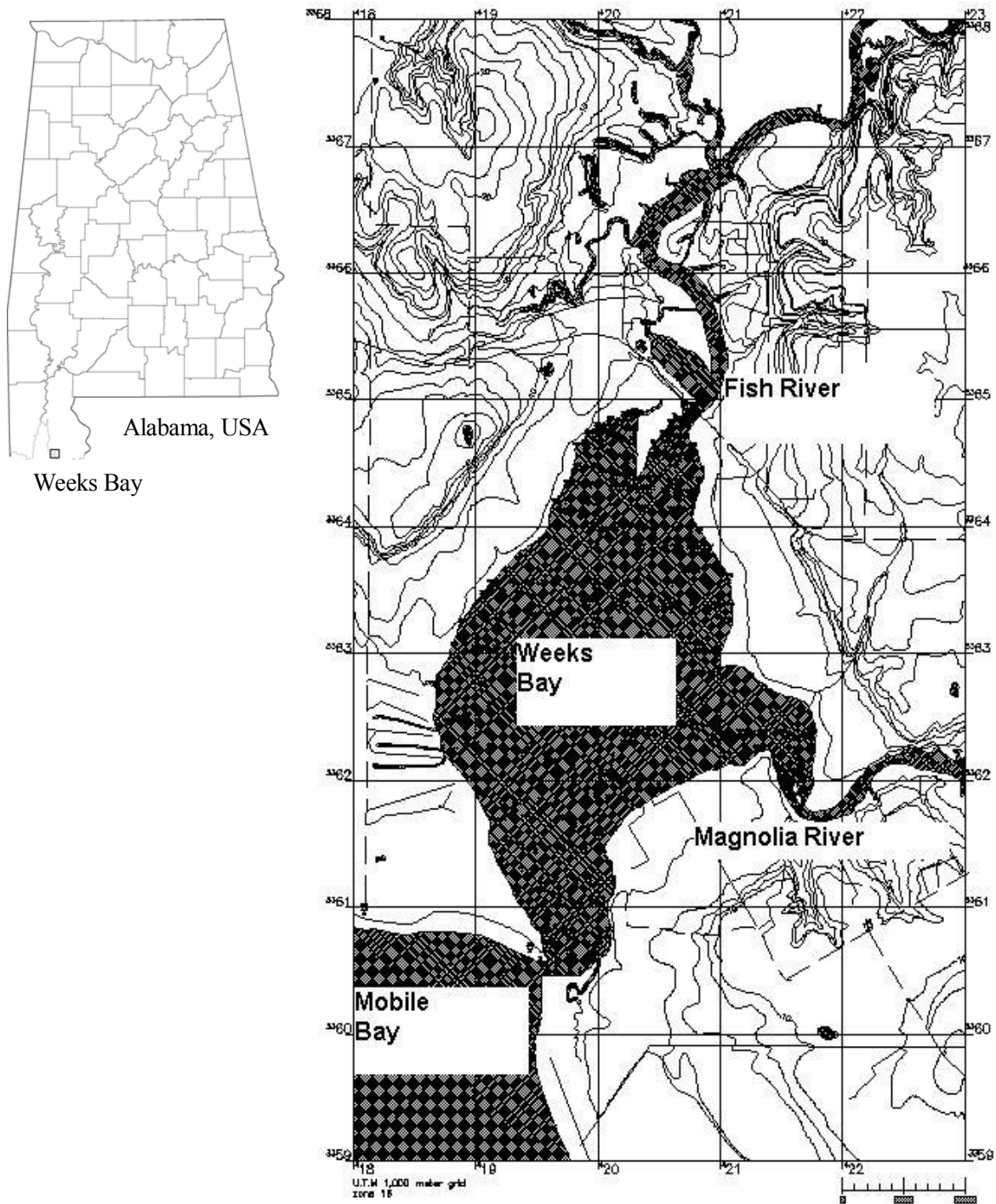

Figure 1: Weeks Bay, Alabama, USA. State map modified from <http://alabamamaps.ua.edu> and location map modified from <http://www.usouthal.edu/geography/baywick/weeksbay.htm>.

sustained perturbations. The Ecopath and Ecosim software have been under development since 1989 (Christensen and Pauly 1992). The Ecopath model was originally derived from an approach first developed by Polovina (1984), which was then combined with the approach of Ulanowicz (1980) for analysis of flows. Ecosim was an extension of the Ecopath model to allow for dynamic simulation of responses (Walters et al. 2000). The Ecopath and Ecosim models have been applied to many different systems throughout the world (Christensen and Pauly 1993). However, there are relatively few examples of the application of Ecopath and Ecosim to small, shallow estuaries such as Weeks Bay.

As a National Estuarine Research Reserve (NERR), Weeks Bay, Alabama, USA has been extensively studied for the past 20 years, and provides an excellent case study for modeling the seasonality and dynamics of a pulse-driven estuarine ecosystem. In this system, species composition and biomass changes occur across seasons. With seasonal Ecopath snapshots, I will attempt to answer the question: how does the structure and function of the food web vary among the seasons? I also explore the importance of detrital resources to the structure and function of the food web, and explore the trade-off between detrital and imported energy sources. Extreme variation in the amount of precipitation delivered to the Weeks Bay watershed leads to years of high and low river discharge into the estuary that can cause transient disruptions of the quasi-equilibrium state of the ecosystem. Potential future development in the watershed and global climate change will likely affect the river flow patterns and nutrient inputs into Weeks Bay. Using the Ecosim model, I examine how the Weeks Bay system is predicted to respond to perturbations in phytoplankton production that would result from changes in river flow or nutrient inputs, and predict the time required for the system to recover to pre-perturbation conditions. Return time is one indication of an ecosystem's sensitivity to perturbation. Scenarios

examined include single pulses of high or low river flows, multiple years of successive high or low flows, and the effects of the magnitude and grouping of high and low flows years. These scenarios will answer the question: how do pulses of nutrients and changing nutrient loads affect the food web? I conclude with a synthesis of the Ecopath and Ecosim results, and a general discussion of the strengths and weaknesses of the Ecopath and Ecosim modeling approach.

METHODS

Study Area

Weeks Bay is a small, shallow sub-estuary of Mobile Bay, Alabama, USA. Weeks Bay has an average depth of approximately 1 m, covers 6.95 km², and has a tidal range of about 0.4 m. There are two freshwater rivers that flow into Weeks Bay (Fish and Magnolia Rivers), and water is exchanged with Mobile Bay through a single tidal channel. There are distinct seasonal variations in physical and environmental conditions (e.g., river flow) affecting Weeks Bay. Mean river discharge is about 9 m³s⁻¹ for both the Fish and Magnolia Rivers (combined), with freshets of up to 4 times mean flow occurring throughout the year. Rainfall on the eastern and western shores of Mobile Bay averages 165 cm annually, and air temperature varies from average highs of 33 °C in the summer to lows of -7 °C every other year on average (Miller-Way et al. 1996). Tropical storms frequently make landfall along the central Gulf coast, and from 1871 through 1980 an average of 2.2 tropical storms made landfall along every 18.5 km stretch of the coast, delivering an average of 13 to 25 cm of intense rainfall (Miller-Way et al. 1996).

There are permanent and seasonal residents in the biota of Weeks Bay. Zooplankton, phytoplankton, and benthic algae are ubiquitous within the system, and undergo only slight seasonal shifts in species composition. Benthic fish (*Paralichthys* spp. and *Citharichthys* spp.) and blue crab (*Callinectes sapidus*) are present in the estuary year-round, while penaeid shrimp (*Farfantepenaeus aztecus*, *F. duorarum*, *Litopenaeus setiferus*) undergo seasonal migrations into and out of Weeks Bay. Among the nekton, bay anchovy (*Anchoa mitchilli*), gulf menhaden (*Brevoortia patronus*), piscivorous fish (mainly *Caranx* spp.), carnivorous fish (*Cynoscion* spp.), and marine mammals (*Tursiops truncatus*) are present in varying densities throughout the year. Atlantic croaker (*Micropogonias undulatus*), spot (*Leiostomus xanthurus*), mullet (*Mugil*

cephalus & M. curema), and gelatinous zooplankton densities vary among the seasons.

Ecopath

To develop an Ecopath model, functional groups are first defined based on ecological similarity. Next, Ecopath requires the parameterization of an equation that describes production for each functional group. The equation for production of each group i is:

$$P_i = Y_i + B_i \cdot M2_i + E_i + BA_i + M0_i \quad \text{Eq. 1}$$

where P_i = total production rate of group i ; Y_i = total fishery catch of group i ; B_i = biomass of group i ; $M2_i$ = total predation rate on group i ; E_i = net migration rate of group i ; BA_i = biomass accumulation of group i ; $M0_i$ = other predation rate on group i . In my application to Weeks Bay, a separate Ecopath model was constructed for each 3 month (quarter) season. The units of P , Y , E , BA , and $M0$ are quarter⁻¹; $M2$ and B have units of gdw m⁻². I assumed no fishery harvest ($Y=0$), and no accumulation of biomass of any of the groups within each season ($BA=0$). The other predation rate ($M0_i$) is defined as $P_i(1-EE_i)$, where EE_i = ecotrophic efficiency of group i . Ecotrophic efficiency is an adjustment parameter used to balance the food web.

Equation (1) can be re-expressed in terms of a system of n linear equations for n groups as:

$$B_i \cdot (P/B)_i \cdot EE_i - \sum_{j=1}^n B_j \cdot (Q/B)_j \cdot DC_{ji} - Y_i - E_i - BA_i = 0 \quad \text{Eq. 2}$$

where $(P/B)_i$ = production to biomass ratio of group i , $(Q/B)_j$ = consumption to biomass ratio of group j , and DC_{ji} is the fraction of prey i in the diet of predator j . In equation (2), the production rate of group i in equation (1), P_i , has been expressed as biomass times the P/B ratio, adjusted for the ecotrophic efficiency, and the total predation rate on group i in equation (1), $B_i M2_i$, has been expressed as the summed consumption by all predators eating group i .

Invoking that the system is in steady-state (biomass of each group does not change over time), the following equation must hold:

$$Q_i = P_i + R_i + U_i \quad \text{Eq. 3}$$

where Q_i = consumption of group i , R_i = respiration of group i and U_i = unassimilated food of group i . If the total consumption of each group did not balance the production and loss terms (respiration and unassimilated biomass), then the biomass of group i would change over time.

Required inputs for creating an Ecopath model are three of the four following parameters: B_i , $(P/B)_i$, $(Q/B)_i$, and EE_i . Ecopath developers recommend specifying B_i , $(P/B)_i$, and $(Q/B)_i$ (Christensen et al. 2000). Once these three parameters are entered for each group, a diet composition matrix is constructed. The diet matrix is constructed by designating the percent of each prey that occurs in each predator's diet. The Ecopath model then is checked for steady-state conditions. The elements of the diet matrix or the values of the three inputted parameters are adjusted until the EE_i for each group is between zero and one. A value of ecotrophic efficiency less than zero would imply that MO must be greater than P , which according to equation (1) would require one of the other terms to be negative. A value of ecotrophic efficiency greater than one would require P to be negative.

Once a balanced Ecopath model is obtained, the flows of biomass among the groups and higher-order indices of ecosystem functioning can be interpreted. Ecopath provides the flows of biomass among groups that satisfies the steady-state condition, and that are also consistent with the inputted values of production (P), biomass (B), and consumption (Q). Several network analysis indices are also produced by Ecopath, which are useful for determining an ecosystem's structure, maturity, and stability (Odum 1969; Ulanowicz 1980). These indices are total system throughput (T), ascendancy (A), system capacity (C), and system overhead, which is based on

ascendency and capacity. Total system throughput (T) represents the entire amount of biomass flow within the system. Ascendency (A) measures the structure of an ecosystem in terms of the amount and organization of biomass flow within the system. Based upon Odum's (1969) interpretation of the attributes of ecosystems, more speciation, finer specialization, longer retention, and more cycling within the system indicate that an ecosystem is more mature. Higher ascendency values indicate that there is an increase in one or more of these properties. The upper limit to ascendency is the development capacity (C) of the ecosystem. System overhead is the difference between capacity and ascendency. System overhead is the upper limit to how much ascendency can increase to counteract unexpected perturbations. Higher overhead indicates that a system has a larger amount of energy reserves with which it can react to perturbations, so that the system should be more able to maintain stability when perturbed. Equations for how each of these indices are calculated from Ecopath estimates of biomass flows and inputted parameters are given in Appendix 1.

Ecosim

Ecosim allows for time-dynamic simulations and is comprised of a series of coupled differential equations:

$$dB_i / dt = f(B) - M_o B_i - F B_i - \sum_{j=1}^n c_{ij}(B_i, B_j) \quad \text{Eq. 4}$$

where dB_i/dt = growth rate in biomass of group i , $f(B_i)$ = the production rate of group i , M_o = natural mortality rate of group i , F = fishing mortality rate of group i , and c_{ij} is a function that predicts the consumption rate of group i at any given time from B_i and B_j (Walters et al. 1997). The system of equations are solved on a monthly time step for up to one hundred years. In my application to Weeks Bay, biomass is in units of gdw m^{-2} , $f(B_i)$ and consumption rate have units

of $\text{gdw m}^{-2} \text{ quarter}^{-1}$, and M_o and F have units of quarter^{-1} . In practice, an Ecopath model is used to set initial conditions for Ecosim simulations, and used to provide estimates of some of the consumption-related and production-related parameters of the Ecosim model.

I used a simple functional form for consumption. Consumption is based on the Lotka-Volterra or ‘mass action’ assumption as $c_{ij}(B_i, B_j) = a_{ij}B_iB_j$, where a_{ij} is the instantaneous mortality rate on prey i caused by one unit of predator j biomass. Each of the a_{ij} values are obtained from the Ecopath model as $a_{ij} = Q_{ij}/(B_iB_j)$ or $c_{ij}(B_i, B_j) = Q_{ij}$. More complicated functional forms for consumption are available that involve specifying vulnerabilities of each prey group to each predator group. I used the simple product of biomasses for the consumption function in all Weeks Bay model simulations.

For primary producers, production, $f(B_i)$, is a simple saturating production rate defined as

$$f(B_i) = r_i B_i / (1 + B_i h_i) \quad \text{Eq. 5}$$

where r_i = maximum P/B of group i when B_i is low, and r_i/h_i = maximum net primary production rate of group i when biomass does not limit production. The ratio of maximum to initial P/B specified in the initial Ecopath model is used to calculate r_i , and then h_i is calculated from the relationship $[(r_i/(P/B)) - 1]/B_i$. For consumers, production, $f(B_i)$, represents the consumption of group i prey by group j predators through the equation

$$f(B) = g_i \sum_{j=1}^n c_{ji}(B_i, B_j) \quad \text{Eq. 6}$$

where g_i is the net growth efficiency of group i defined by its production to consumption $(P/Q)_i$ ratio, and c_{ji} is the function that predicts consumption from B_i and B_j (i.e., $c_{ji}(B_i, B_j) = a_{ji}B_iB_j$).

Forcing functions can either be drawn by hand, or values from a spreadsheet can be used to shape them. The forcing functions can be applied to the production of primary producer groups or to the Q/B of each consumer group.

Ecopath: Weeks Bay

Four season-specific Ecopath models were constructed for Weeks Bay to investigate seasonal differences among the food webs. The four models were: winter (January-March), spring (April-June), summer (July-September), and fall (October-December). Water temperature estimates from Brackin (2001) were used to define each season. Mean temperatures were 15.2° C in winter, 23.3° C in spring, 29.0° C in summer, and 17.7° C in fall. There were 14 groups present in all four seasons: marine mammals, carnivorous fish, benthic fish, croaker, spot, bay anchovy, gulf menhaden, penaeid shrimp, blue crab, zooplankton, zoobenthos, phytoplankton, benthic algae, and detritus. Gelatinous zooplankton and piscivorous fish were included in the spring, summer, and fall only, and mullet were included in the winter and fall only. Ecopath parameters (production, biomass, consumption) and predicted biomass flows were compared among seasons for individual groups, and for groups aggregated into the categories of: phytoplankton, benthic algae, zoobenthos, zooplankton, large invertebrates (blue crab, penaeid shrimp, and gelatinous zooplankton), forage fish (mullet, menhaden, anchovy, spot, and croaker), and top predators (marine mammals, piscivorous fish, carnivorous fish, and benthic fish).

Data sources for Ecopath parameters are shown in Table 1, and the values of the parameters are shown in Table 2. B_i , P/B , and Q/B were entered for each group. Rough qualitative information was used to construct the initial diet matrix, which was then adjusted until steady-state conditions (all ecotrophic efficiencies between zero and one) was achieved in each of the four seasons.

Data from the Noel (2000) study of Weeks Bay was used to estimate the average biomass for phytoplankton, zooplankton, gelatinous zooplankton, bay anchovy, and gulf menhaden. Noel (2000) used push nets and otter trawls to collect specimens from Weeks Bay, which I used to determine daily average biomass, and growth and production rates. Phytoplankton biomass was calculated from reported daily chlorophyll-*a* concentrations. Reported zooplankton densities were converted to biomass by applying the average weight per individual reported in Rose et al. (1999). For gelatinous zooplankton, reported biovolume was converted to biomass using a conversion factor provided by M. Graham, Dauphin Island Sea Lab, AL (personal communication). For bay anchovy and gulf menhaden, biomass was calculated from reported densities that were multiplied by an average weight by length-class using length-weight regressions obtained as part of the Noel (2000) study.

P/B for phytoplankton and zooplankton and Q/B for zooplankton were estimated from an Ecopath model created for the northern Gulf of Mexico (Browder 1993). P/B and Q/B for gelatinous zooplankton were obtained from M. Graham, Dauphin Island Sea Lab, AL (personal communication). P/B and Q/B for bay anchovy and gulf menhaden were obtained, and adjusted for the average temperature in each season, from reported studies in the Gulf of Mexico (Fishbase 2000). Parameters for benthic algae and zoobenthos were obtained from the literature. Benthic algae biomass by season was estimated from chlorophyll-*a* concentrations reported in Schreiber (1994), while P/B values were obtained from Browder (1993). Biomass of zoobenthos was estimated by average weight per individual multiplied by reported densities in Bain and Robinson (1990). P/B values were estimated from the production rates calculated from equations in Edgar (1990), divided by the average biomass values. Q/B values for zoobenthos were estimated from Manickchand-Heileman et al. (1998).

Data from Brackin (2001) was used to estimate biomass by season for blue crabs, penaeid shrimp, croaker, and spot. Brackin (2001) calculated monthly mean density of each species; I multiplied the densities by the area of Weeks Bay to estimate the number of individuals per square meter, and then converted from numbers to biomass using species-specific values of mean weight per individual. Penaeid shrimp and blue crab P/B and Q/B values were estimated from an Ecopath model created by Manickchand-Heileman et al. (1998). P/B and Q/B for croaker and spot were obtained from reported values for these species in Fishbase (2001).

Biomasses of carnivorous fish, benthic fish, major piscivores, and mullet were estimated from survey data reported by the Dauphin Island Laboratory of the Alabama Department of Conservation and Natural Resources (W. Ingram, personal communication). These data were collected in Weeks Bay using trawls. CPUE was multiplied by the area swept by the trawl to obtain number of individuals per square meter. Average length reported in the trawls and species-specific length-weight relationships (Fishbase 2001) were used to convert numbers to biomass. P/B and Q/B for all four groups were obtained from values reported for these species in Fishbase (2001).

Parameters for marine mammals were estimated from information provided by the National Marine Fisheries Service, Mississippi Laboratories surveys conducted in Mobile Bay (T. Henwood, personal communication.). Numbers per hectare were used as rough guides to estimate biomass. P/B and Q/B for marine mammals were obtained from Browder (1993).

I considered biomass estimates for each functional group to be the most reliable data when constructing the Ecopath models. To assure that estimated values for P/B were reasonable, I compared them to the P/B values reported in Christensen and Pauly (1993), a collection of over 50 individual Ecopath models. These comparisons showed that the estimates were well within

Table 1: Sources of the input parameters of biomass, and the ratios of production to biomass P/B and consumption to biomass Q/B for the four season-specific Ecopath models

	Biomass (gdw m ⁻²)	P/B (quarter ⁻¹)	Q/B (quarter ⁻¹)
Phytoplankton	Noel (2000)	Browder (1993)	N/A
Benthic algae	Schrieber (1994)	Browder (1993)	N/A
Detritus	Manickchand- Heileman et al. (1998)	N/A	N/A
Zoobenthos	Bain and Robinson (1990)	Bain and Robinson (1990) and Edgar (1990)	Manickchand- Heileman et al. (1998)
Zooplankton	Noel (2000) and Rose et al. (1999)	Browder (1993)	Browder (1993)
Blue crab and penaeid shrimp	Brackin (2001)	Manickchand- Heileman et al. (1998)	Manickchand- Heileman et al. (1998)
Gelatinous zooplankton	Noel (2000)	Graham (pers. comm.)	Graham (pers. comm.)
Mullet, benthic fish, carnivorous fish, and piscivorous fish	Alabama Dept. of Conservation and Natural Resources	Fishbase (2001)	Fishbase (2001)
Menhaden and anchovy	Noel (2001)	Fishbase (2001)	Fishbase (2001)
Spot and croaker	Brackin (2001)	Fishbase (2001)	Fishbase (2001)
Marine mammals	NMFS Mississippi Laboratories	Browder (1993)	Browder (1993)

Table 2: Input parameters of biomass, and the ratios of production to biomass P/B and consumption to biomass Q/B for the four season-specific Ecopath models. Biomass is in units of g dw m^{-2} ; P/B and Q/B are in units of quarter^{-1} .

	Winter			Spring			Summer			Fall		
	Biomass	P/B	Q/B	Biomass	P/B	Q/B	Biomass	P/B	Q/B	Biomass	P/B	Q/B
Phyto-plankton	2.598	82.07	-	2.217	84.24	-	1.3	129.5	-	1.667	111	-
Benthic algae	3.639	2.573	-	1.445	9.373	-	14.64	2.25	-	31.781	1.439	-
Detritus	4	-	-	4	-	-	4	-	-	4	-	-
Zoobenthos	2.74	7.836	7.908	3.609	10.846	13.686	2.413	5.67	12	4.12	8	16
Zooplankton	0.661	12.744	26.693	1.156	35	73.096	0.301	54.6	210	0.319	12.744	26.693
Blue crab	1.051	0.132	0.684	0.904	1.766	7.81	1.14	0.171	3.54	1.044	0.151	0.684
Penaeid shrimp	0.055	1.219	3.889	0.435	4.424	15.13	0.424	0.603	4.465	6.931	0.453	3.889
Gelatinous zooplankton	-	-	-	0.083	5	15	0.183	5	20	1.5	2.5	10
Mullet	0.01	0.052	2.932	-	-	-	-	-	-	0.006	0.047	3.07
Menhaden	0.014	2.441	7.429	0.147	1.405	7.955	0.066	0.263	2.025	0.085	1.739	7.429

(Table 2 continued)

Table 2 (continued)

	Winter			Spring			Summer			Fall		
	Biomass	P/B	Q/B	Biomass	P/B	Q/B	Biomass	P/B	Q/B	Biomass	P/B	Q/B
Anchovy	0.068	1.059	10.029	0.032	3.602	15.119	1.541	2.22	5.5	0.074	1.909	3.85
Spot	0.566	0.636	15.713	1.307	0.521	17.651	0.692	0.149	2.625	0.168	0.019	5.025
Croaker	0.287	0.816	5.566	1.589	0.38	7.257	0.384	0.426	2.575	0.474	1.262	5.566
Marine mammals	0.022	0.213	4.208	0.253	0.213	4.518	0.25	0.23	4.11	0.25	0.23	4.11
Benthic fish	0.001	0.861	7.306	0.013	0.331	12.481	0.003	0.393	3.625	0.002	0.083	2.025
Carnivorous fish	0.006	0.208	7.431	0.034	0.254	5.235	0.011	0.308	3.6	0.001	0.087	3.6
Piscivorous fish	-	-	-	0.004	0.362	5.092	0.004	0.108	1.675	0.001	0.108	1.675

the range of P/B values reported for similar functional groups. Reported P/B values for phytoplankton generally fell within a range of 70 to 150 year⁻¹. The seasonal values in my models ranged from about 80 quarter⁻¹ in the winter to near 130 quarter⁻¹ in the summer. For zooplankton, reported P/B values of greater than 75 quarter⁻¹ were common in the Ecopath models. The highest estimated P/B for zooplankton in my summer model was close to 74 quarter⁻¹. For benthic primary producers, reported P/B values ranged from about 3 to 10 quarter⁻¹, while my estimates ranged from about 2 quarter⁻¹ in the winter to close to 9 quarter⁻¹ in the summer. Reported P/B values for invertebrates in the other Ecopath models ranged from about 0.5 to 8 quarter⁻¹ for crustacea and mollusks, to near 20 quarter⁻¹ for small soil infauna and epifauna. The seasonal values in my models varied from over 0.1 quarter⁻¹ for blue crab in the winter to 12 quarter⁻¹ for zoobenthos in the summer. For fishes, reported P/B values varied from less than 0.1 quarter⁻¹ for larger predators to more than 3 quarter⁻¹ for smaller herbivores. Estimates of P/B values for the fish groups in the four seasonal models (0.2 to about 1.2 quarter⁻¹ in winter; maximum values of 3.6 for quarter⁻¹ anchovy in spring and 5.5 quarter⁻¹ for croaker in the fall) with most values within the reported range. Q/B values are difficult to measure and are rarely reported. The main sources of Q/B estimates were previous Ecopath models.

Ecopath snapshots of the Weeks Bay food web for each of the four seasons are shown in Figures 5 through 8. The Ecopath parameters of biomass, production, and consumption were inputted in the model; and the biomass flow rates shown among the groups were derived by Ecopath, assuming steady-state conditions. I compared the mean biomass, production, and Ecopath-derived biomass flows among the groups, and for the groups aggregated into categories, for each of the four seasons. The contribution of detritus and importation of biomass to various groups were examined and contrasted among the seasons. In addition, the mean trophic level of

each group and the higher-order indices of throughput, ascendancy, and capacity were compared among the seasons.

Various summaries of the Ecopath parameters and the biomass flows shown in Figs. 5 to 8 are presented in Tables 3 to 8. Table 3 shows the average biomass and production by category and season, as inputted into Ecopath model. Table 4 shows the average trophic level, as computed by Ecopath, for each category by season. Table 5 shows the biomass consumed by each category as the predator and trophic level as the prey. Table 6 compares the biomass of detritus and of import by category and season needed to satisfy the steady-state condition, while keeping ecotrophic efficiencies between zero and one. Table 7 summarizes the biomass flows of detritus to each of the categories by season. Table 8 presents the Ecopath-derived values of throughput, ascendancy, overhead, and capacity for each of the seasons.

Ecosim: Weeks Bay

The same food web (17 functional groups) used in the Ecopath model also was used in Ecosim simulations. The four seasonal Ecopath models were averaged to produce a single yearly model, which provided the initial conditions, estimates of the a_{ij} , and estimates of r_i of primary producers for Ecosim. Short-term (20-year) and long-term (100 year) simulations were performed. Short term simulations modeled the effects of single pulses of wet and dry years. Long term simulations modeled within-year and interannual changes in river flow.

The driving variable of river flow was varied in Ecosim simulations as a surrogate for changes in phytoplankton primary production. The river flow variable was applied to the production rate of the phytoplankton group. I assumed that a major effect of river flow is the delivery of nutrients that fuel the production of phytoplankton (Day et al. 1989). Baseline values of the river flow forcing variable were estimated using 30 years of river flow data measured at

USGS streamflow gauge number 02378500 located at the mouth of the Fish River. I first computed the total annual average flow, and average flow by month, over the 30-year period. Next, each monthly average flow was divided by the average annual flow to obtain the baseline river flow (Fig. 2). In each month of a simulation, phytoplankton primary production rate was multiplied by the value of the river flow driving variable. The baseline pattern shown in Fig. 6 was repeated every year of the simulation.

Short-term (20-year) Ecosim simulations were performed to evaluate the effects of pulses of single high-flow or single-low flow years. First, a 20-year baseline simulation was performed that used the baseline river flow. Based on qualitative examination of the USGS river flow data, I defined a high-flow year as a 20% increase (Fig 3B) and a low-flow year as a 20% decrease (Fig. 3C) in the river flow driving variable. A single high-flow year or a single low-flow year was imposed for year 10 of the 20-year simulations. Biomass of each functional group was followed for the 9 years following each of the pulses. Additionally, the responses of each group to the high-flow or low-flow pulses was characterized by reporting the change in peak biomass under pulsed conditions from the peak biomass under baseline, and by reporting the number of months required from the end of the pulse to recovery of biomass to pre-perturbation levels.

Long-term (100-year) simulations were performed to evaluate the effects of within-year extremes of high-flow and low-flow conditions, and to evaluate the effects of variation in the interannual cycle of high-flow and low-flow years. First, a 100-year baseline simulation using the baseline river flow forcing variable was performed (years 1 to 10 shown in Fig. 4A). The river flow forcing variable then was modified to produce extremes of high and low flow conditions for each year of the 100 year simulation. Flow during the wettest months of the year was increased by approximately 40%, and flow during the driest months of the year was

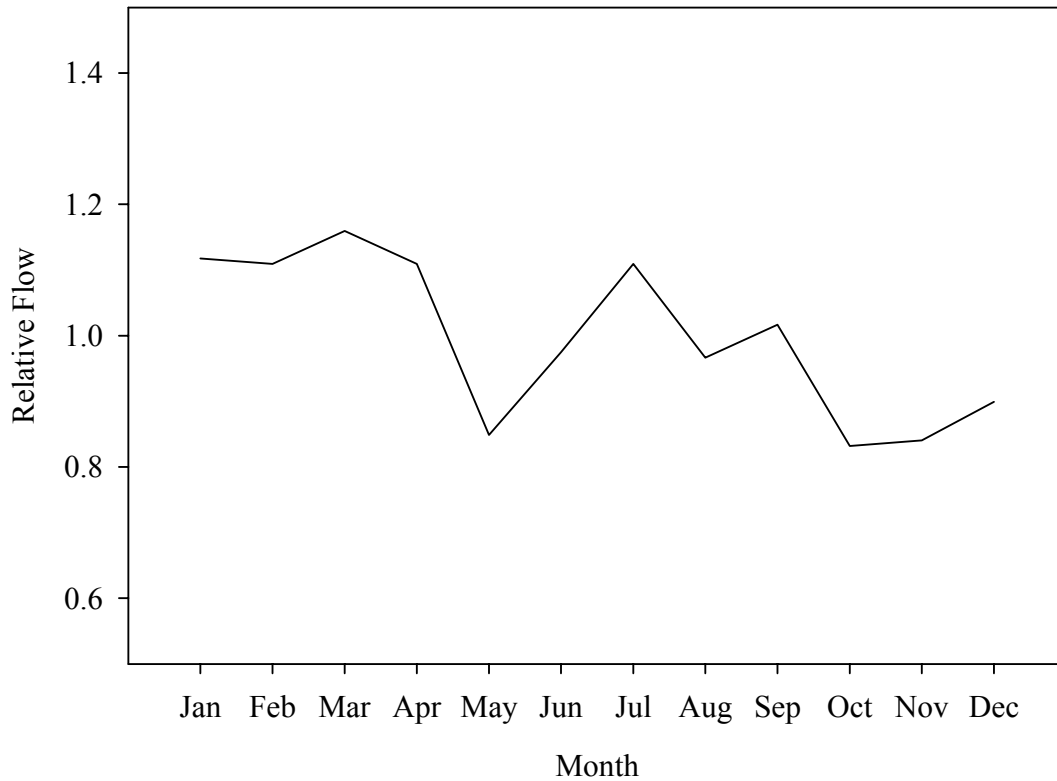

Figure 2: Monthly river flow driving variable derived from flow data measured at USGS stream gauge number 02378500 located in the mouth of the Fish River. River flow is the monthly average flow divided by the average annual flow.

decreased by approximately 40% (Fig. 4B). To allow for direct comparison to the baseline simulation, I adjusted monthly river flows so that the total amount of water each year of the extreme within-year simulations was identical to the amount of water during the baseline simulation. Time-series plots of biomass were used to determine the response pattern of each of the 17 groups. Additionally, average monthly biomass of each group for years 10 to 100 was calculated for the baseline, extreme high-flow, and extreme low-flow simulations, and the percent change of average biomass from baseline was calculated for the high-flow and low-flow simulations

For simulation of interannual changes in river flow patterns, a cycle of two high-flow years

followed by four low-flow years was simulated for 100 years (years 1 through 10 shown in Fig. 4C). The historical USGS flow gauge data showed a weak but consistent pattern of one to two very strong high-flow years followed by several low-flow years. The river flow forcing variable during high-flow years was increased by 20% over baseline, and decreased by 10% from baseline during the low-flow years. The combination of the two high-flow years at a 20% increase followed by four low-flow years at a 10% reduction resulted in the same total amount of river flow in the system as under baseline conditions. Time-series plots of biomass were used to determine the response pattern of each of the 17 functional groups.

Additionally, average monthly biomass of each group for years 10 to 100 was calculated for the baseline and the interannual variation (two high-flow years followed by four low-flow years) simulations, and the percent change of average biomass from baseline was computed from the average values. The interannual cycle simulation resulted in a net increase or decrease in the average biomass of some of the higher trophic level groups compared to baseline conditions. Two additional simulation experiments were therefore performed to further understand the causes of the net changes in the average biomasses of these groups. The first additional experiment was a 2 x 2 factorial experiment to investigate the effects of grouping of high-flow and low-flow years and the effects of the magnitude of river flow. To keep the same total river flow in all simulations, I assumed there were an equal number of high-flow and low-flow years in the 100 year simulations. The factor of magnitude had two levels: 20% and 40%. The 20% change involved increasing baseline river flow by 20% for high-flow years and decreasing river flow by 20% for low-flow years. The 40% change involved increasing river flow by 40% for high-flow years and decreasing river flow by 40% for low-flow years. The other factor in the experiment was how the high-flow and low-flow years were arranged over time. "Ungrouped"

had alternating high-flow and low-flow years for 100 years; "grouped" had four successive high-flow years followed by four successive low-flow years, repeated for the 100 years. I used four successive years of high-flow and low-flow conditions because the interannual variation simulation, which resulted in the net change in biomasses of some groups, had a pattern that involved four low-flow years in a row. I report the average monthly biomass over the 100 years for each of the groups for the 2 x 2 experiment (i.e., four simulations).

The second additional experiment was designed to investigate whether the number of high-flow versus low-flow years influenced the change in biomass predicted in some functional groups. I performed a 100-year simulation that reversed the cycle of two high-flow years followed by four low-flow years used in the interannual variation simulation. The additional simulation consisted of two low-flow years (a 20% decrease over baseline) followed by four high-flow years (a 10% increase over baseline). Time series plots of biomass are shown for each of the groups of interest.

Figure 3: High- and low-flow pulses of river flow in year 10 used in the short-term simulations. Years 10 to 20 are shown. (A) baseline, (B) high-flow pulse in year ten, (C) low-flow pulse in year 10.

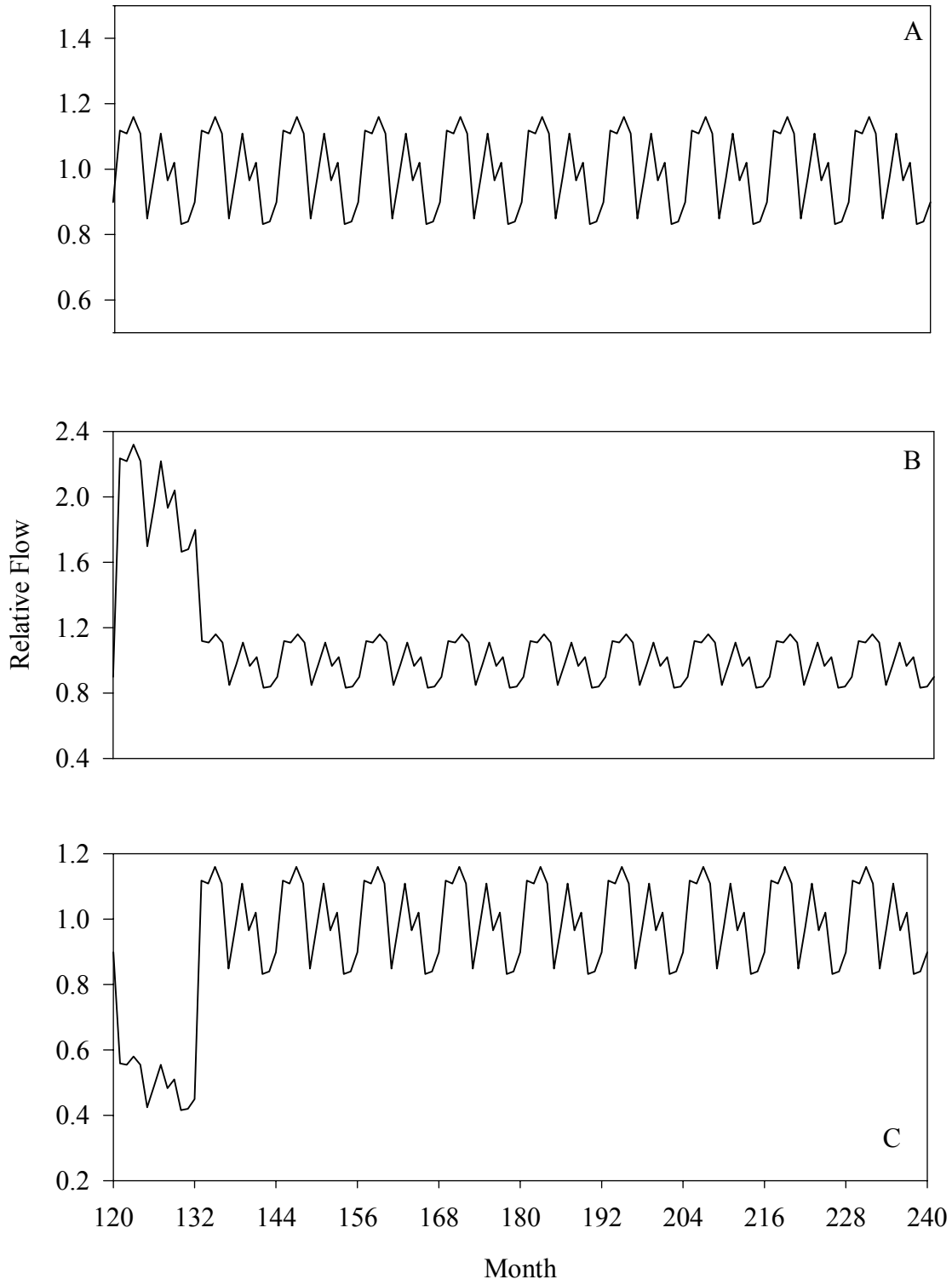
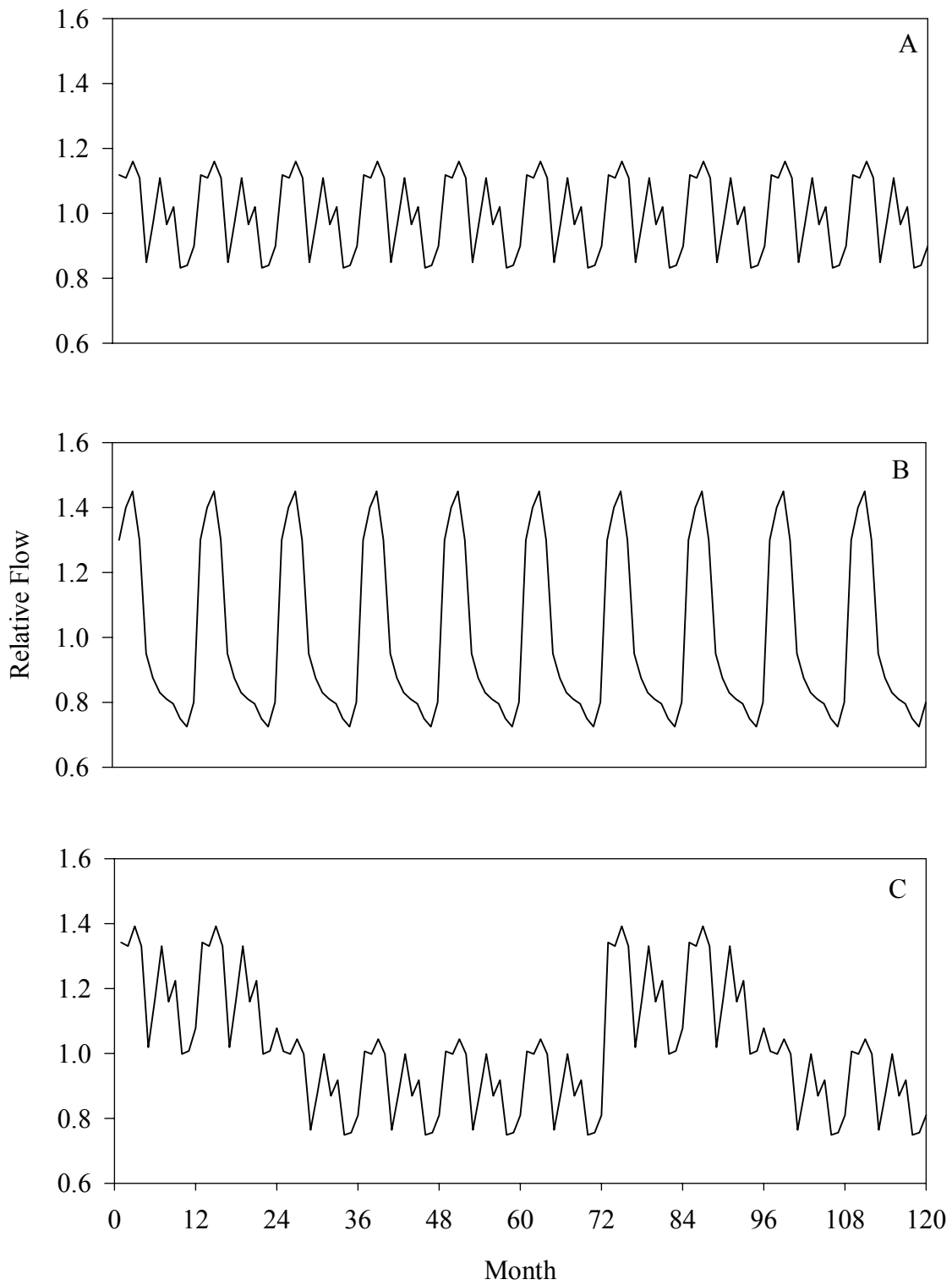

Figure 4: River flow driving variable for the long-term simulations under (A) baseline, (B) within-year extreme, and (C) interannual variation conditions. Years 1 to 10 are shown.



RESULTS

Ecopath: Weeks Bay

Biomass flows as calculated under steady-state conditions by Ecopath are shown in Figs. 5 to 8. Biomass for most of the model groups generally peaked in spring and fall seasons and, except for zoobenthos, was generally low in the winter (Table 3). Biomass of top predators, forage fish, and zoobenthos was highest in the spring (0.286, 3.075, and 3.609 gdw m⁻² respectively), while biomass of large invertebrates and zoobenthos peaked in the fall (9.475 and 4.120 gdw m⁻²). Lowest biomass was in the winter for top predators and large invertebrates, in the fall for forage fish and zoobenthos, and in the summer for zooplankton.

The difference between maximum and minimum biomass was greatest for zooplankton, top predators, and large invertebrates, and relatively small for forage fish and zooplankton (Table 3). The ratio of maximum to minimum biomass was 13-fold (fall to summer) for zooplankton, ten-fold (spring, summer, or fall to winter) for top predators, and eight-fold (fall to winter) for large invertebrates. Forage fish showed only four-fold differences (spring to fall), and zoobenthos showed only a two-fold difference (fall to summer).

Top predators and large invertebrates had their greatest production when their biomass was highest (spring and fall), whereas forage fish, zooplankton, and zoobenthos had their greatest production at intermediate biomass levels (summer, spring, and fall, respectively) (Table 3). The ratio of maximum to minimum production was 34-fold (fall to winter) for large invertebrates, ten-fold for top predators (spring to winter) and zooplankton (spring to fall), and five-fold for forage fish (summer to winter). Zoobenthos, which had the smallest difference in biomass levels, also had the smallest ratio of maximum to minimum production (less than three-fold, spring to summer).

Figure 5: Derived biomass flows among groups for the winter season. Ecopath input parameters of biomass, production, and consumption are given in Table 2.

Figure 6: Derived biomass flows among groups for the spring season. Ecopath input parameters of biomass, production, and consumption are given in Table 2.

Figure 7: Derived biomass flows among groups for the summer season. Ecopath input parameters of biomass, production, and consumption are given in Table 2.

Figure 8: Derived biomass flows among groups for the fall season. Ecopath input parameters of biomass, production, and consumption are given in Table 2

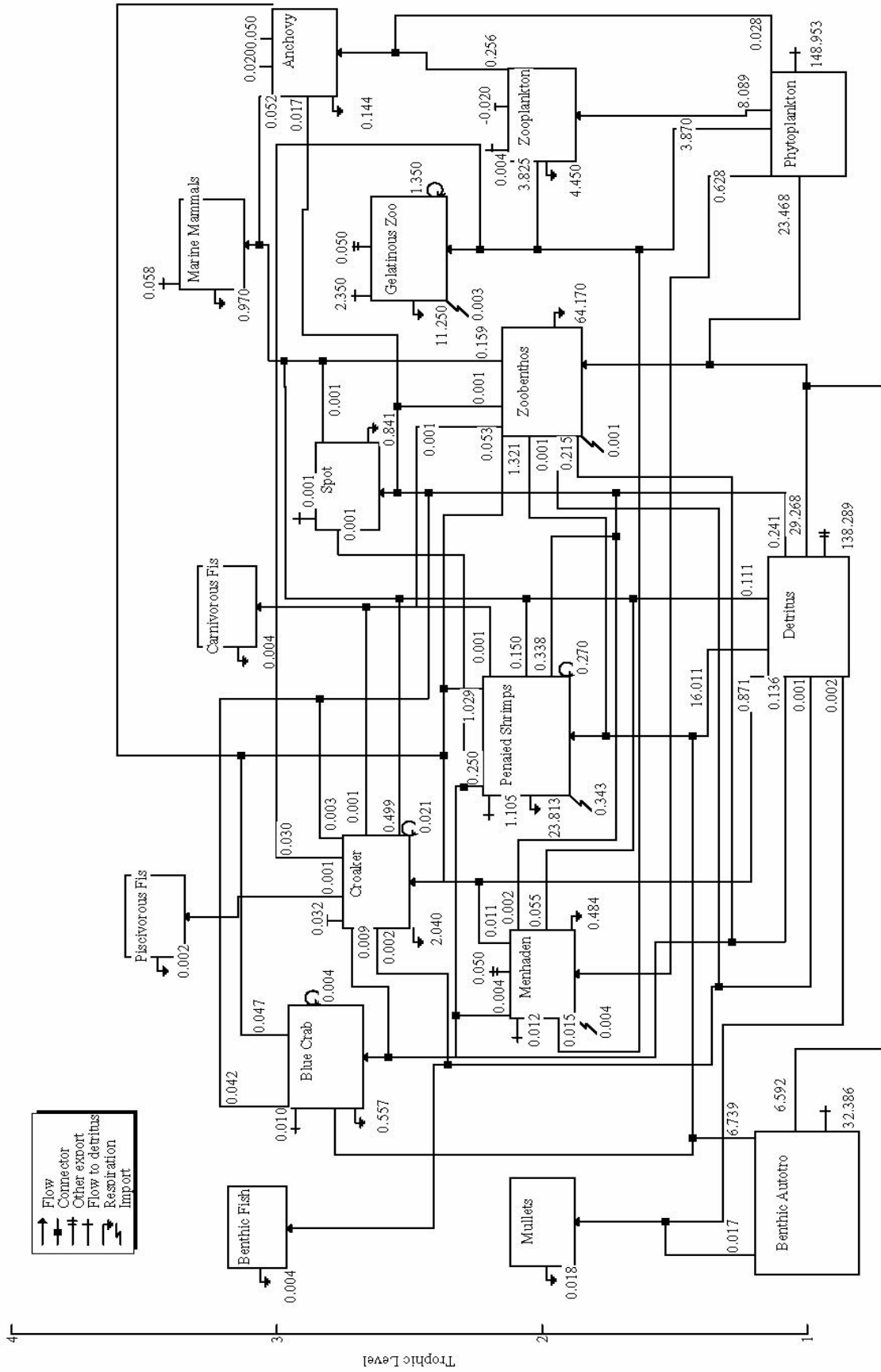

The average trophic level of groups aggregated into categories (Table 4) showed that top predators, large invertebrates, and zoobenthos occupied their highest trophic levels during the summer (3.96, 2.75, and 2.15 respectively) and their lowest trophic levels during the fall (3.25, 2.46, and 2.00 respectively). The forage fish category also achieved its highest trophic level during summer (2.94), but had its lowest trophic level during the spring (2.39) rather than the fall. There was no change in the average trophic of zooplankton across the four seasons (always 2.00).

Top predators fed mostly from trophic levels III and IV, forage fish and large invertebrates mostly from trophic levels II and III, and zoobenthos and zooplankton mostly from trophic level II (Table 5). Large invertebrates and zoobenthos played major roles in the fall, resulting in consumption from trophic level II being ten-times higher than consumption from trophic level III (110.312 versus 11.732 gdw m^{-2}). In the other three seasons, consumption by large invertebrates and zoobenthos were smaller, and zoobenthos consumption was spread over trophic levels II and III. This resulted in a contribution of trophic level II that was only four- to five-times the consumption from trophic level III (43.133 versus 10.402 gdw m^{-2} for winter; 152.207 versus 30.255 gdw m^{-2} in spring; 92.591 versus 17.511 gdw m^{-2} in summer).

Phytoplankton contributed the greatest amount of biomass to the detrital pool in all seasons, while zoobenthos and zooplankton were important in the spring and benthic algae was important in the fall (Table 6). Winter and summer were roughly similar in the categories contributing to detritus, with the major difference being the much larger contribution from phytoplankton in the winter compared to the summer (192.230 versus 96.963 gdw m^{-2}). During the spring and fall, phytoplankton was also the major contributor to detritus, but zoobenthos and zooplankton in the spring (20.082 and 37.033 gdw m^{-2}) and benthic algae in the fall (32.386 gdw m^{-2}) also were

Table 3: Season-specific Ecopath parameters of biomass and production by categories of groups. Biomass is in units of gdw m^{-2} ; production is in units of $\text{gdw m}^{-2} \text{ quarter}^{-1}$.

	Winter Biomass	Winter Production	Spring Biomass	Spring Production	Summer Biomass	Summer Production	Fall Biomass	Fall Production
Top predators	0.029	0.007	0.286	0.068	0.268	0.063	0.254	0.061
Forage fish	0.937	0.702	3.075	1.606	2.683	3.705	0.807	0.891
Large invertebrates	1.106	0.206	2.911	2.447	1.747	1.356	9.475	7.049
Zoobenthos	2.740	21.469	3.609	39.142	2.413	13.682	0.319	32.69
Zooplankton	0.661	8.426	1.156	40.471	0.301	16.435	4.120	4.065

important contributors. Large invertebrates, forage fish, and top predators contributed very little to the detrital pool in all four seasons.

Table 4: Average trophic level estimated by Ecopath for each group aggregated into categories by season.

	Winter	Spring	Summer	Fall
Top predators	3.67	3.26	3.96	3.25
Forage fish	2.57	2.39	2.94	2.56
Large invertebrates	2.54	2.73	2.75	2.46
Zoobenthos	2.05	2.05	2.15	2.00
Zooplankton	2.01	2.00	2.00	2.00

Import of biomass was greatest at the middle trophic levels and during the winter and spring seasons (Table 6). In the winter, biomass of large invertebrates and zooplankton were imported, while forage fish biomass was exported. In the spring, biomass of zooplankton, zoobenthos, large invertebrates, and forage fish were all imported. Little import of biomass occurred in the summer and fall seasons.

As expected, zoobenthos was the major consumer of detritus in all four seasons, with utilization of detritus generally being the highest in the spring and fall seasons (Table 7). In every season except fall, zoobenthos was the greatest consumer of detritus; spring consumption of detritus (28.387 gdw m⁻²) was second highest to fall (29.268 gdw m⁻²). Large invertebrates, which had their peak biomass in the fall, also consumed significant amounts of detritus in the fall. Zooplankton and forage fish utilized detritus relatively more during the spring season (5.333 and 9.170 gdw m⁻²) than in the other seasons (< 2.531 gdw m⁻²).

Table 5: Biomass consumption (gdw m⁻² quarter⁻¹) by categories of groups as predators and trophic levels as prey for each season.

	Winter				Spring				
	II	III	IV	V	II	III	IV	V	VI
Top predators	0.001	0.038	0.102	0.007	0.329	0.652	0.447	0.068	0.003
Forage fish	2.657	8.636	0.732	0.016	14.120	19.024	2.971	0.130	0.001
Large invert	0.323	0.581	0.029	-	6.559	7.868	0.448	0.003	-
Zoo-benthos	20.520	1.147	-	-	46.678	2.711	-	-	-
Zoo-plankton	19.632	-	-	-	84.521	-	-	-	-
Total	43.133	10.402	0.863	0.023	152.207	30.255	3.866	0.201	0.004
	Summer					Fall			
	II	III	IV	V	VI	II	III	IV	V
Top predators	0.002	0.148	0.872	0.062	0.002	0.135	0.601	0.282	0.016
Forage fish	1.095	8.719	1.549	0.051	-	2.237	2.004	0.173	0.002
Large invert	3.643	4.329	1.602	0.014	-	33.505	9.127	0.034	0.002
Zoo-benthos	24.641	4.315	-	-	-	65.920	-	-	-
Zoo-plankton	63.210	-	-	-	-	8.515	-	-	-
Total	92.591	17.511	4.023	0.127	0.002	110.312	11.732	0.489	0.020

Table 6: Biomass flows to detritus and biomass imported by categories of groups for each season.

	Winter to Detritus	Winter Import	Spring to Detritus	Spring Import	Summer to Detritus	Summer Import	Fall to Detritus	Fall Import
Top predators	0.007	-	0.062	-	0.60	-	0.058	-
Forage fish	0.390	-0.167	0.125	0.178	0.525	0.011	0.065	-0.004
Large invertebrates	0.114	0.4	0.215	0.503	0.348	0.007	3.465	0.001
Zoobenthos	13.428	-	20.082	0.655	11.562	0.067	0	0.001
Zooplankton	6.437	1.2	37.033	0.681	1.551	0.002	0.004	0.020
Benthic algae	1.261	-	6.919	-	3.840	-	32.386	-
Phytoplankton	192.230	-	96.963	-	94.733	-	148.953	-

* Negative values indicate export.

Table 7: Utilization (consumption) of detrital biomass (gdw m⁻² quarter⁻¹) by categories of groups by season.

	Winter	Spring	Summer	Fall
Top predators	0.001	0.241	0.002	0.112
Forage fish	2.531	9.170	0.917	1.114
Large invertebrates	0.278	3.159	0.745	16.147
Zoobenthos	10.282	28.387	13.120	29.268
Zooplankton	0.837	5.333	-	-

Table 8: Higher-order indices of ecosystem development and functioning (throughput, ascendancy, overhead, and capacity) as calculated by Ecopath for each season.

	Winter	Spring	Summer	Fall
Throughput	490	563	454	555
Ascendency	616	747	648	795
Overhead	495	1441	874	1077
Capacity	1115	2213	1521	1873

Higher-order indices of ecosystem functioning showed that the winter food web was least developed, spring and summer food webs were intermediate in development, and the fall food web was the most developed (Table 8). Capacity and overhead were lowest in the winter (1,115 and 495) and highest in the spring (2,213 and 1,441). This implied that the winter food web was least resistant, and the spring food web was the most resistant, to perturbation. The high potential for development embodied in high values of capacity and overhead in the spring was then used up as the system became more organized and the food web became more fully developed in the summer, culminating in the fall when ascendancy peaked. Lowest ascendancy in the winter and

highest ascendancy in the fall implied that the winter food web was least developed and specialized, and that the fall food web was the most developed food web.

Ecosim: Baseline

Short-term baseline simulations produced cyclic behavior at the lowest trophic levels that was gradually dampened as one moved up the food chain (solid lines in Figs. 9-12). Phytoplankton, zooplankton, zoobenthos, and detritus had the strongest seasonal signals in response to simulated changes in river flow (Fig. 9). There were slight seasonal responses in the groups comprising large invertebrates (penaeid shrimp, and gelatinous zooplankton) and in benthic algae (Fig. 10). Among the forage fish groups, only anchovy and menhaden showed any seasonal response to river flow. Spot, croaker, and mullet biomass remained virtually unchanged over the course of the baseline simulation (Fig. 11). The biomass of the top predators (benthic fish, carnivorous fish, piscivorous fish, and marine mammals) also showed no seasonal cycling, with piscivorous and carnivorous fish showing a slight long-term decline in biomass (Fig. 12).

Ecosim: Pulses

With the exception of anchovy and gelatinous zooplankton among the large invertebrates, the lower trophic level groups that exhibited strong seasonal cycles in response to river flow also showed the largest responses to, and quickest recovery from, single pulses of high-flow and low-flow years (Fig. 9). For example, the percent change peak biomasses compared to peak under baseline conditions for zooplankton was a 218% increase for the high-flow pulse and an 89% reduction for the low-flow pulse (Table 9). These same lower trophic level groups also showed rapid recovery to baseline conditions once the pulse ended; months required for recovery were on the order of 20 months (minimum of 6 to a maximum of 30 months).

Figure 9: Time-series plots of biomass from short term simulations under baseline, high-flow pulse, and low-flow pulse conditions. Pulses were imposed in year 10; years 9 to 20 are shown. (A) phytoplankton, (B) benthic algae, (C) detritus, (D) zooplankton, and (E) zoobenthos.

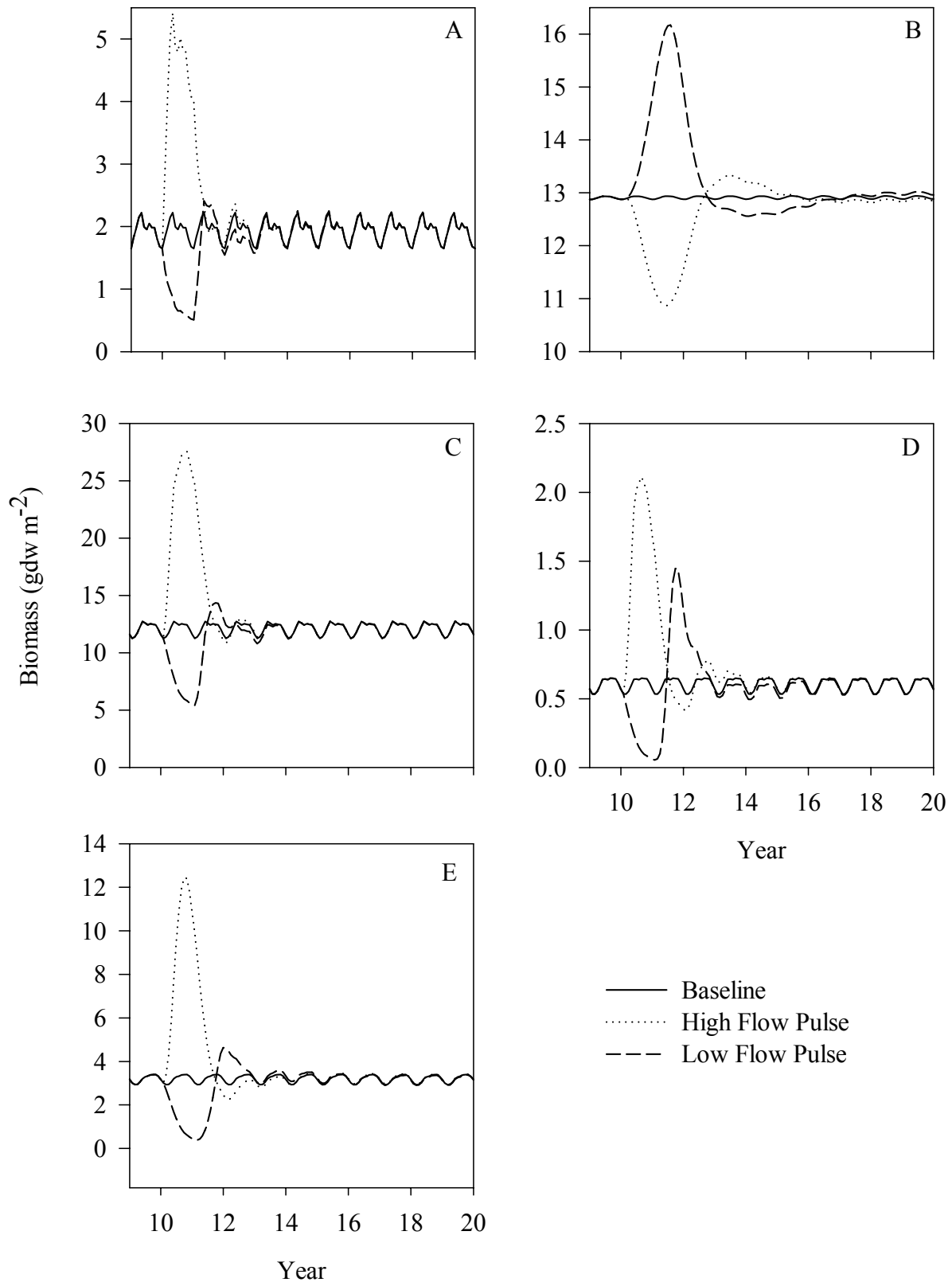

Figure 10: Time-series plots of biomass from short term simulations under baseline, high-flow pulse, and low-flow pulse conditions. Pulses were imposed in year 10; years 9 to 20 are shown. (A) penaeid shrimp, (B) gelatinous zooplankton, and (C) blue crab.

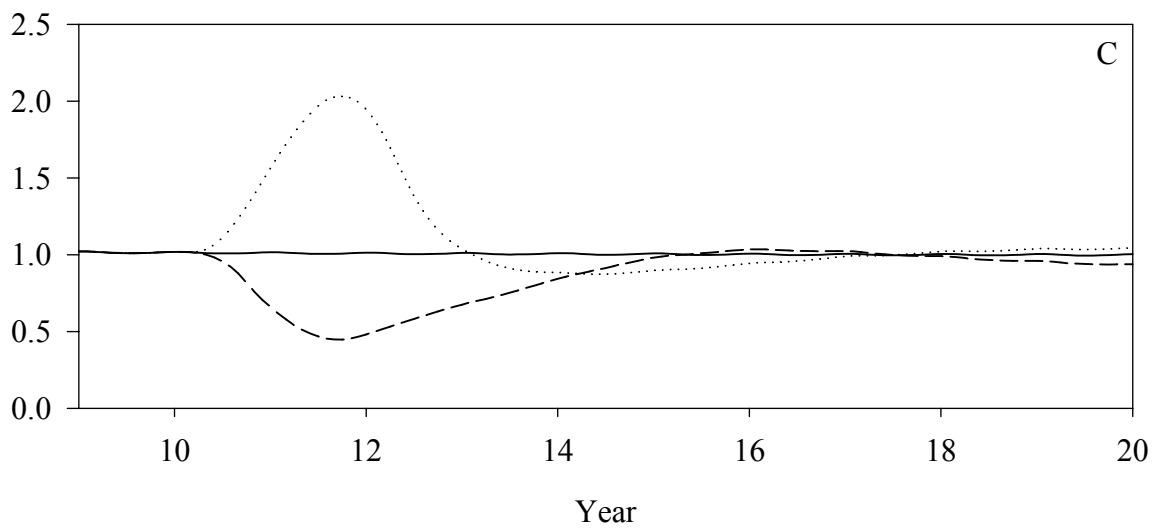
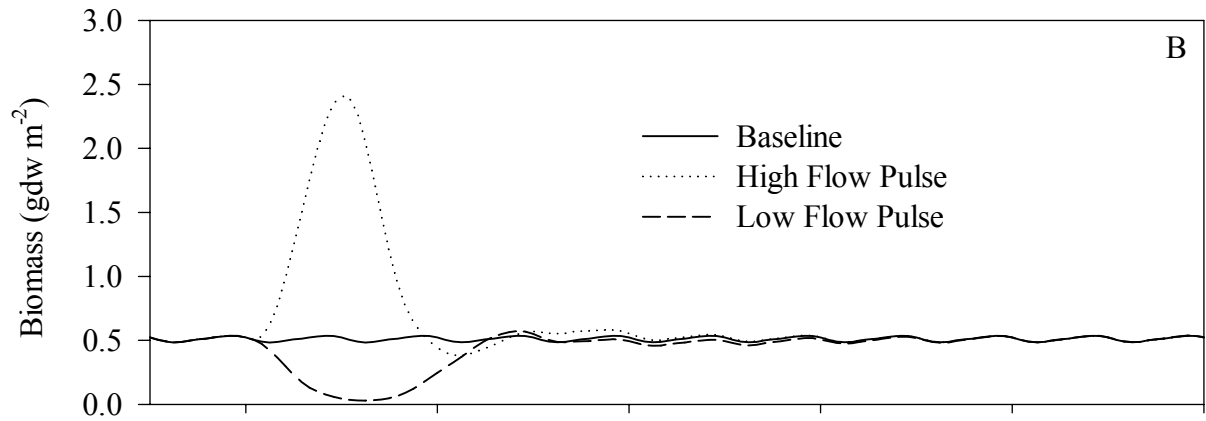
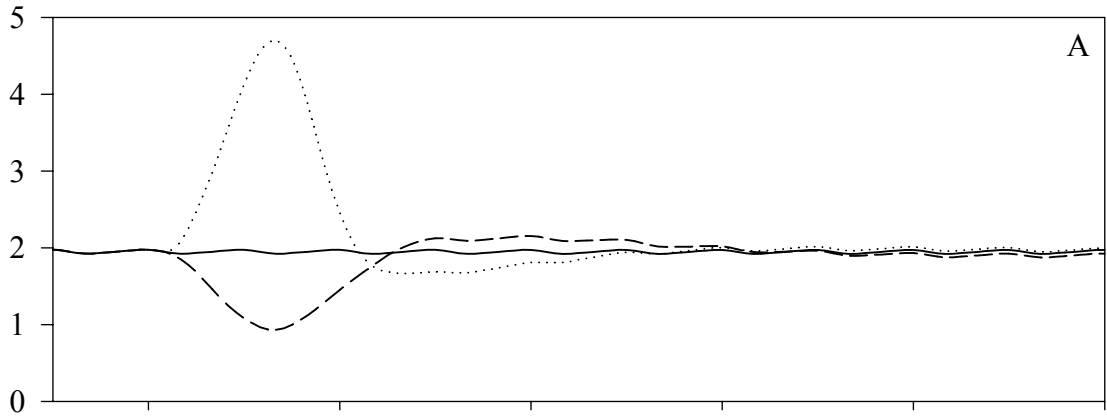

Figure 11: Time-series plots of biomass from short term simulations under baseline, high-flow pulse, and low-flow pulse conditions. The pulses were imposed in year 10; years 9 to 20 are shown. (A) anchovy,(B) menhaden, (C) spot, (D) croaker, and (E) mullet.

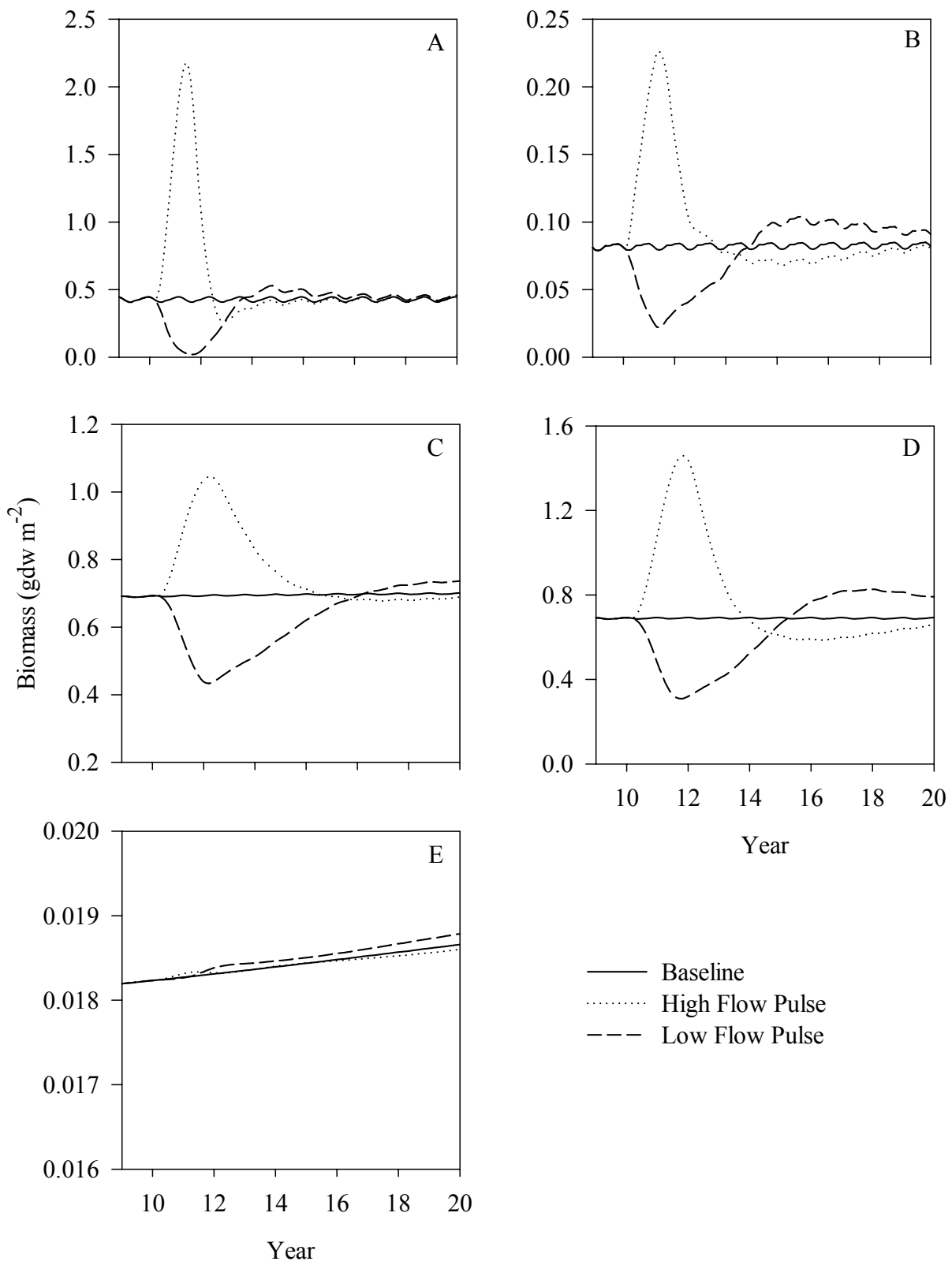
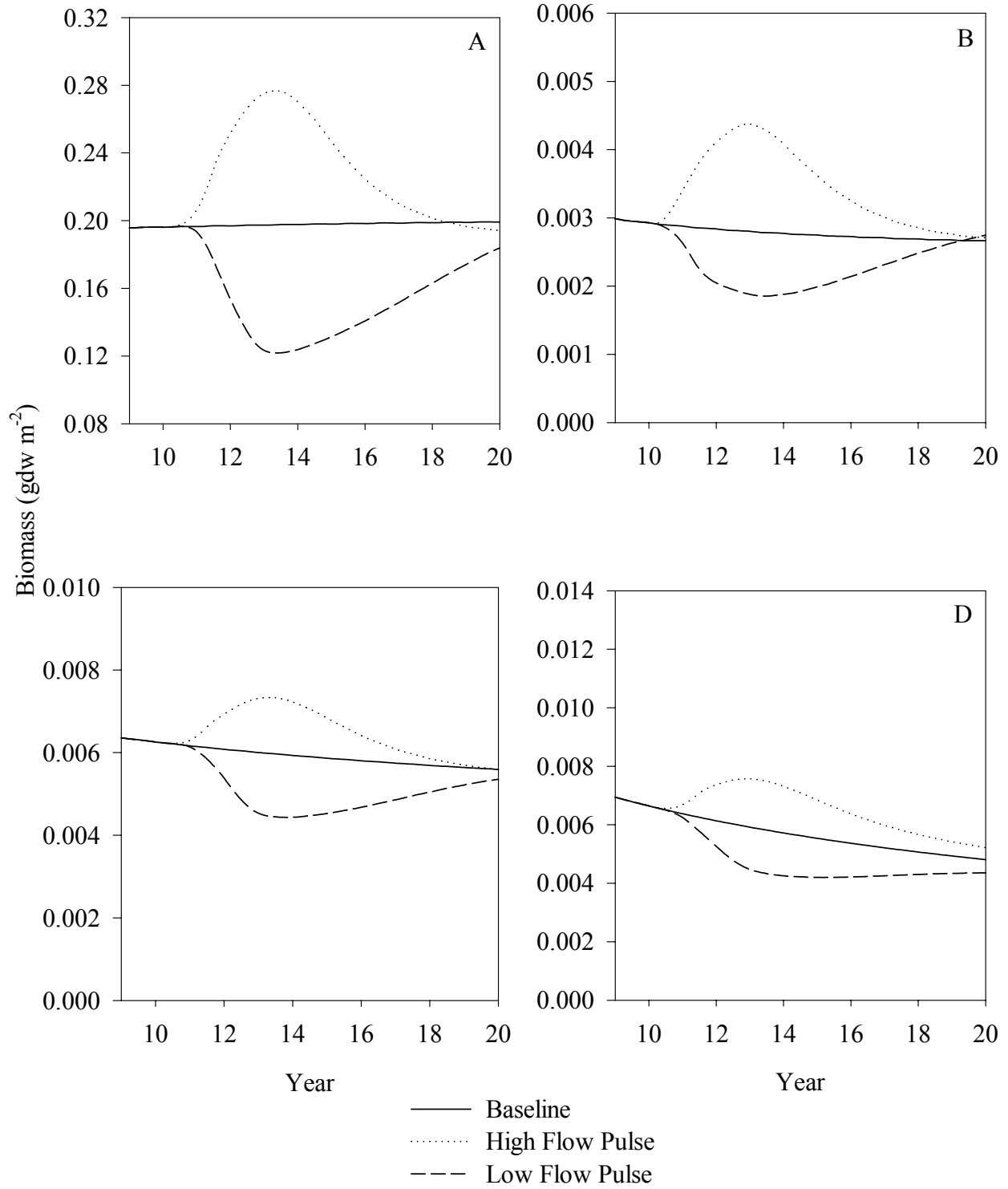

Figure 12: Time-series plots from short-term simulations under baseline, high-flow pulse, and low-flow pulse conditions. The pulses were imposed in year 10; years 9 to 20 are shown. (A) marine mammals, (B) benthic fish, (C) piscivorous fish, and (D) carnivorous fish.



The groups comprising the middle trophic levels showed similar responses to those of the lower trophic levels (Figs. 10 and 11). Anchovy and gelatinous zooplankton had the largest response to both single high-flow and low-flow pulses among any group (389% and 361 % increase during high-flow and 95% and 94% decrease during low-flow) (Table 9). Responses to a single high-flow pulse among other groups at the middle trophic levels ranged from no change in mullet to a 138% increase in penaeid shrimp biomass. Responses to a single low-flow pulse exhibited similar variation among the other middle trophic level groups. Middle trophic level groups took slightly longer to recover to baseline than the lower trophic level groups. Months to recovery ranged from 21 months for gelatinous zooplankton to 64 months for blue crab.

The upper trophic level groups showed generally the smallest responses but required the longest times for recovery (Fig. 12). Increase in peak biomass was less than 56% during a single high-flow pulse for all of the upper trophic level groups, and was generally on the order of 30%. The magnitude of response to a single low-flow pulse was slightly smaller than the magnitude of response to a single high-flow pulse (maximum of 38% reduction). Months required for recovery of the upper trophic level groups were on the order of 100 months (83 to 108).

Ecosim: Within-Year Extremes

More extreme within-year variation in river flow caused exaggeration of the seasonal responses predicted under baseline conditions, and relatively little net change in the average biomass of groups. The biomass of the lower trophic levels groups under the more variable river flow conditions generally exhibited more extreme seasonal cycles but with similar long-term average values as under baseline (Fig. 13). Biomass of penaeid shrimp, gelatinous zooplankton, and blue crab also showed more extreme oscillations, but with a very slight tendency towards a lower long-term average biomass than under baseline (Fig.14). The troughs in biomass of each

annual cycle went slightly lower than the peaks in biomass went higher. This pattern was stronger in the forage fish groups of anchovy (Fig 15A), menhaden (Fig. 15B), and spot (Fig. 15C), less dramatic in croaker (Fig. 15D), and non-existent in mullet who showed no oscillations under both simulations (Fig. 15E). The upper trophic level groups showed a variety of responses, including a slight decrease in biomass of marine mammals (Fig. 16A), a slight increase in biomass of benthic fish (Fig. 16B), and practically no effects on piscivorous fish (Fig. 16 C) and carnivorous fish (Fig. 16D).

Ecosim: Interannual Variation in River Flow

The response of primary producers to interannual variation in high-flow and low-flow conditions (two high-flow years followed by four low-flow years) was similar to their response to within-year extremes in high-flow and low-flow conditions. Biomass of the lower trophic level groups, which were extremely responsive to river flow, mimicked the interannual pattern of high-flow and low-flow years, with little change in their long-term average biomass (Fig. 17). Average phytoplankton, benthic algae, detritus, zoobenthos, and zooplankton biomass changed less than 1.6% from baseline values (Table 10). Whereas phytoplankton responded exactly to the cycle of two years of high-flow and four years of low-flow, the other groups showed some merging of the high-flow and low-flow periods, such that the cycles of benthic algae only showed single peaks and troughs for every cycle.

Among the large invertebrate groups, blue crab biomass showed a somewhat different response to interannual variation than penaeid shrimp and gelatinous zooplankton. Blue crab cycles were characterized by single peaks and troughs, and a 6.8% decline in long-term average biomass. Gelatinous zooplankton and penaeid shrimp biomass also showed single peaks of high biomass in response to two consecutive years of high-flow conditions, and also showed

Table 9: Percent change in peak biomass and the numbers of months required for recovery to baseline biomass levels under pulsed high-flow and low-flow years for each of the groups. Percent change in peak biomass was computed as the peak under pulsed minus the peak under baseline divided by the peak under baseline.

	Percent Change (High Flow)	Months to Recovery (High Flow)	Percent Change (Low Flow)	Months to recovery (Low-Flow)
Phytoplankton	144	6	-69	13
Benthic algae	-16	21	25	21
Detritus	127	9	-52	15
Zoobenthos	266	22	-87	22
Zooplankton	218	30	-89	30
Blue crab	102	64	-56	64
Penaeid shrimp	138	50	-51	50
Gelatinous zooplankton	361	21	-94	21
Mullet	0	0	0	0
Menhaden	169	27	-71	38
Anchovy	389	30	-95	30
Spot	50	62	-37	62
Croaker	110	37	-55	52
Marine mammals	40	83	-38	108
Benthic fish	56	89	-33	89
Carnivorous fish	27	108	-25	108
Piscivorous fish	22	86	-26	108

Figure 13: Time-series plots of biomass for the long-term simulations under baseline and within-year extreme flow conditions. Years 75 to 100 are shown. (A) phytoplankton, (B) benthic algae, (C) detritus, (D) zooplankton, and (E) zoobenthos.

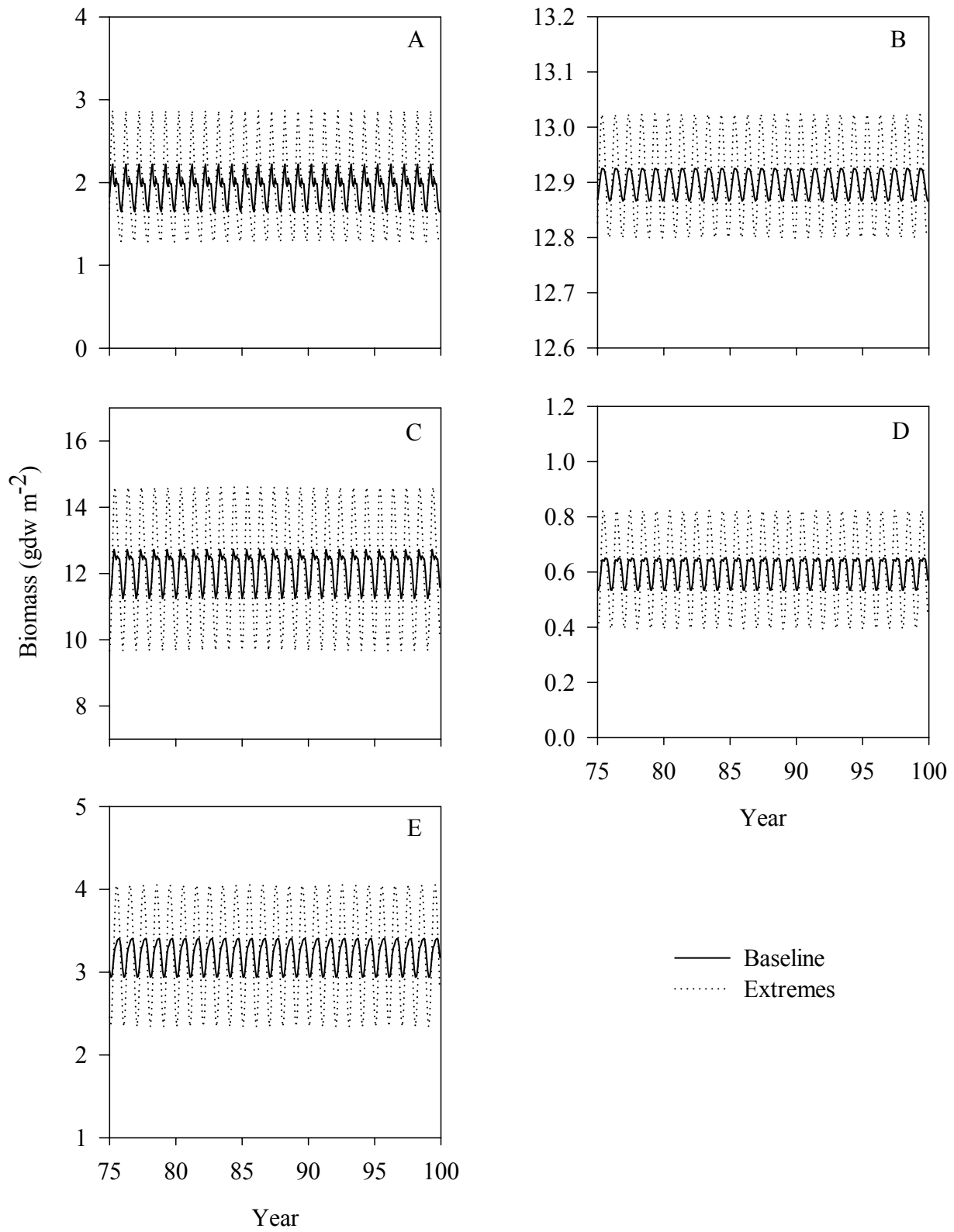

Figure 14: Time-series plots of biomass for the long-term simulations under baseline and within-year extreme flow conditions. Years 75 to 100 are shown. (A) penaeid shrimp, (B) gelatinous zooplankton, and (C) blue crab.

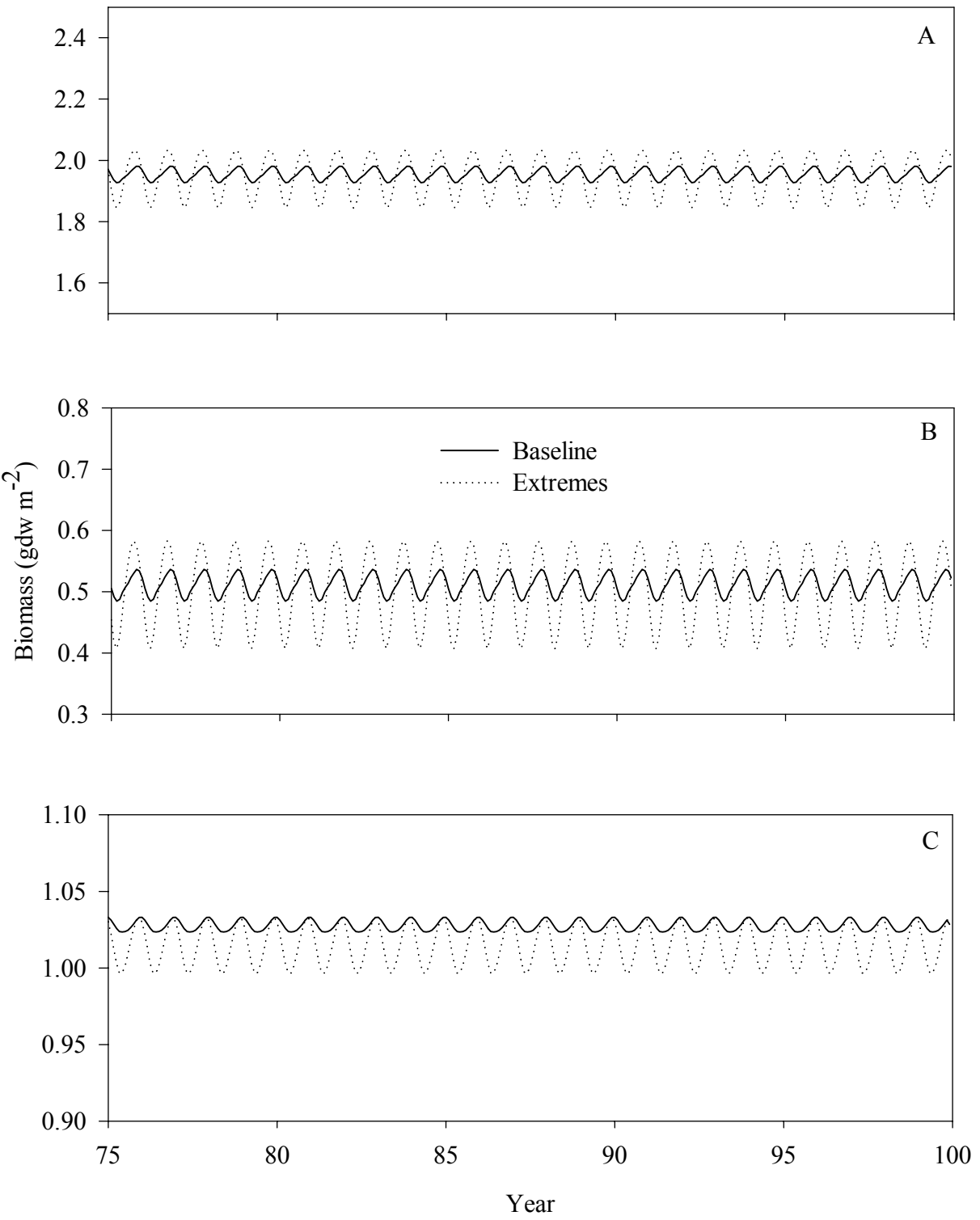

Figure 15: Time-series plots of biomass for the long-term simulations under baseline and within-year extreme flow conditions. (A) anchovy, (B) menhaden, (C) spot, (D) croaker, and (E) mullet.

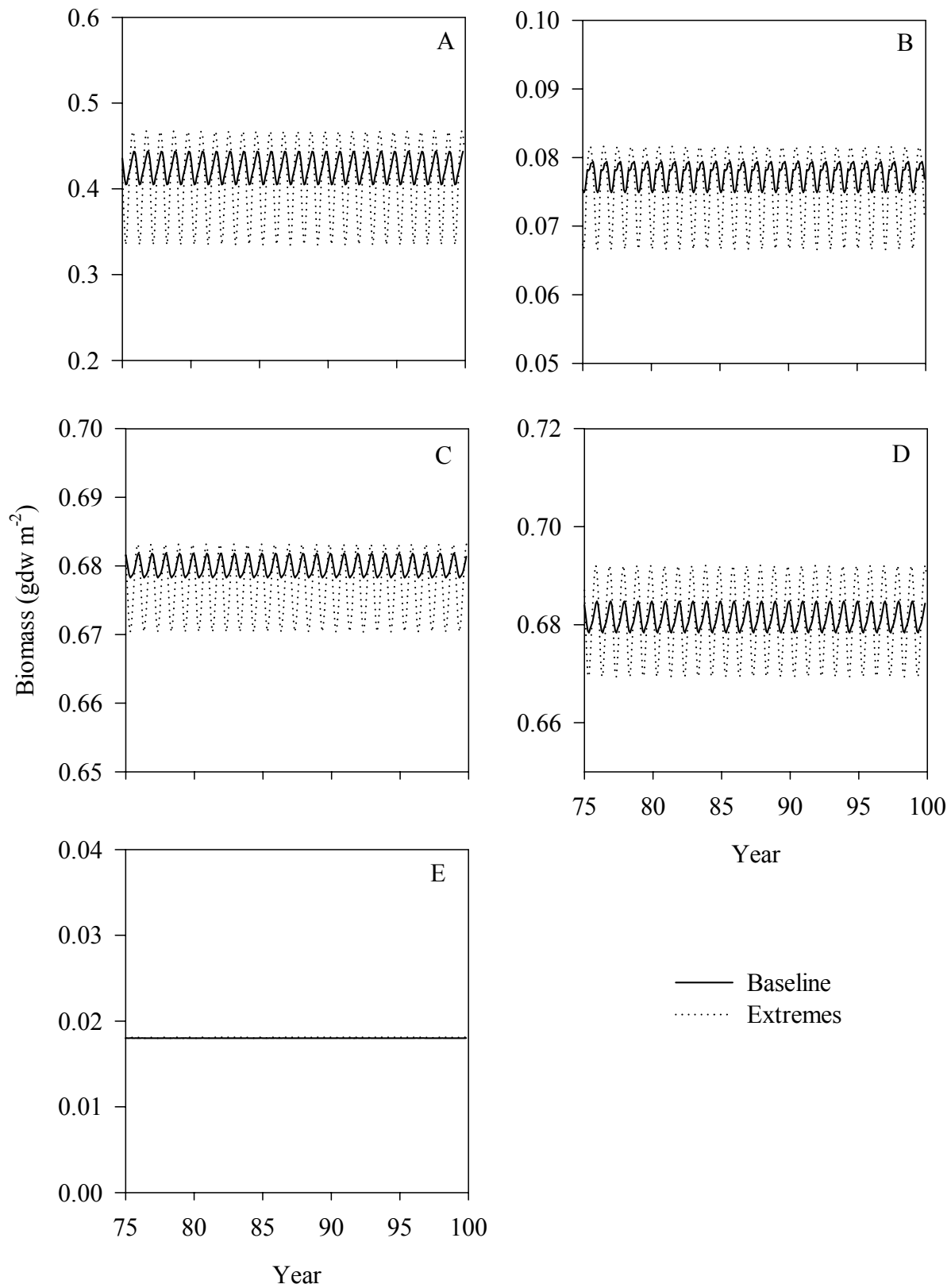
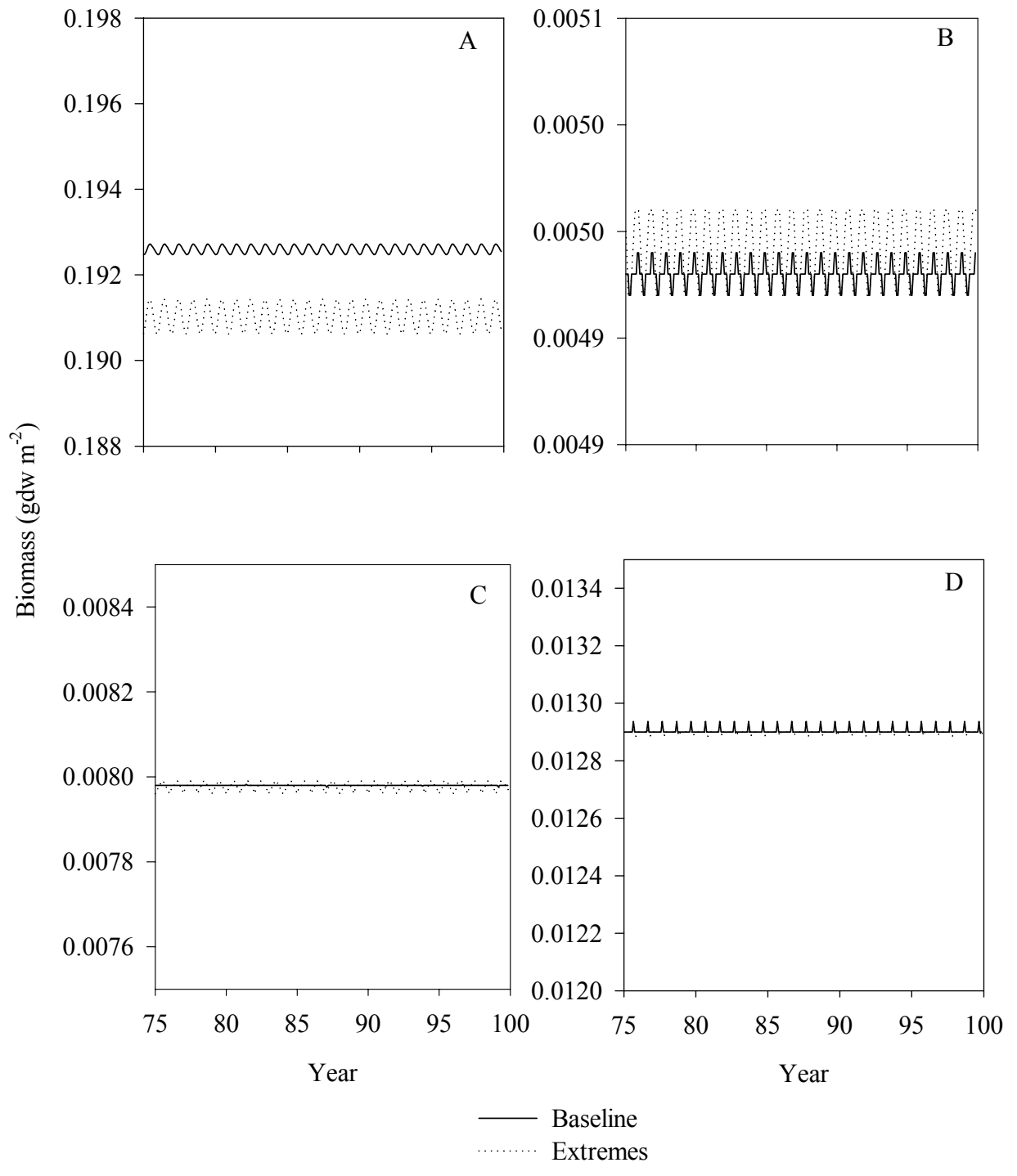

Figure 16: Time-series plots of biomass for the long-term simulations under baseline and within-year extreme flow conditions. Years 75 to 100 are shown. (A) marine mammals, (B) benthic fish, (C) piscivorous fish, and (D) carnivorous fish.



some effects of the four consecutive low-flow years (Fig. 18). Average long-term biomass of the gelatinous zooplankton and penaeid shrimp under the interannual variation simulation showed less than a 1% change in average biomass compared to baseline conditions.

The increased oscillations of forage fish (except mullet) under the interannual variation simulation resulted in a net increase in biomass for anchovy and net decrease in biomass for spot and croaker (Fig. 19, Table 10). Mullet showed little dynamics under baseline and interannual variation simulations. All other forage fish responded to the interannual variation in high-flow and low-flow years by exhibiting cycles with single peaks and roughly single troughs, centered around their baseline values. Mullet and menhaden biomass was essentially unchanged (both were increased by less than 1%), while anchovy had 2.9% higher average biomass, spot biomass was reduced by 4.5%, and croaker biomass was reduced by 2.2% from baseline. However, for all groups, biomass oscillations were well-distributed above and below their baseline values (Fig.19).

Among the top predators, marine mammals, carnivorous fish, and piscivorous fish showed the most dramatic changes in average biomass under the interannual variation simulation. Average biomass of benthic fish was similar between interannual variation and baseline simulations. Average biomass was reduced by 4% for carnivorous fish, by 3.4% for piscivorous fish, and by 5.9% for marine mammals. For marine mammals, carnivorous fish, and piscivorous fish, the troughs of biomass were lower than the peaks, resulting in the cycles not being centered around the baseline values (Fig. 20). While these net changes in average biomass were relatively small in magnitude, they suggest possible changes in key components of the food web.

Further investigation into the causes of the asymmetric responses (net biomass change) of blue crab and top predators revealed that the magnitude of flow, how high-flow and low-flow

Table 10: Long-term average biomass under baseline and under interannual variation simulations, and the percent change from baseline, for each of the groups. Percent change was computed as interannual biomass minus baseline biomass divided by baseline biomass.

	Baseline Biomass (gdw m ⁻²)	Interannual Cycle Biomass (gdw m ⁻²)	Percent Change from Baseline
Phytoplankton	1.94	1.94	-0.1
Benthic algae	12.9	13.0	0.5
Detritus	12.1	12.1	0.2
Zoobenthos	3.21	3.26	1.6
Zooplankton	0.606	0.615	1.4
Blue crab	1.03	0.958	-6.8
Penaeid shrimp	1.95	1.971	0.8
Gelatinous zooplankton	0.511	0.515	0.6
Mullet	0.018	0.018	0.8
Menhaden	0.078	0.078	0.1
Anchovy	0.425	0.437	2.9
Spot	0.680	0.649	-4.5
Croaker	0.681	0.666	-2.2
Marine mammals	0.193	0.181	-5.9
Benthic fish	0.005	0.005	-1.4
Carnivorous fish	0.013	0.012	-4.0
Piscivorous fish	0.008	0.008	-3.4

Figure 17: Time-series plots of biomass for the long-term simulations under baseline (alternating high-and low-flow years) and interannual variation in river flow (two high-flow followed by four low-flow years) conditions. Years 75 to 100 are shown. (A) phytoplankton, (B) benthic algae, (C) detritus, (D) zooplankton, and (E) zoobenthos.

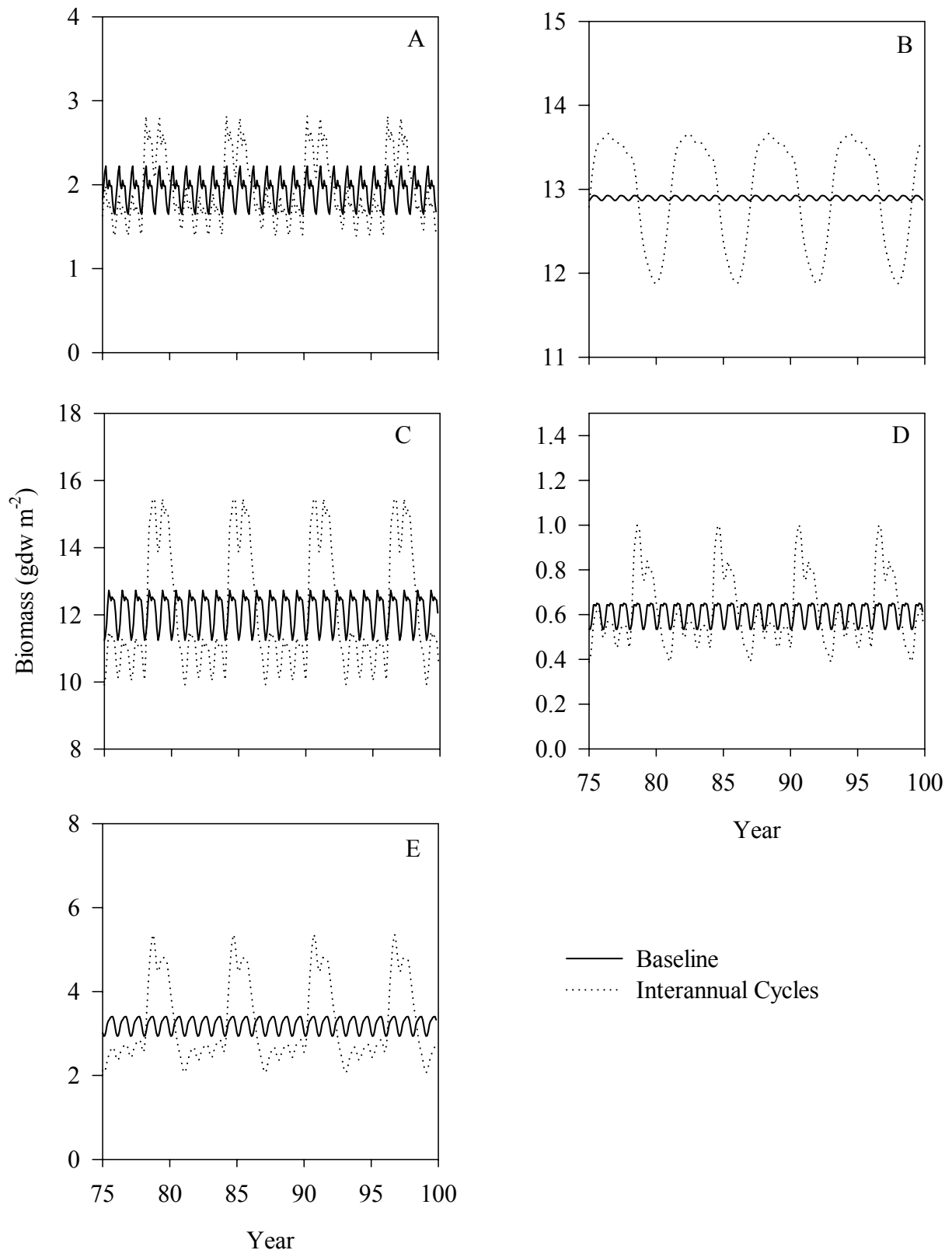
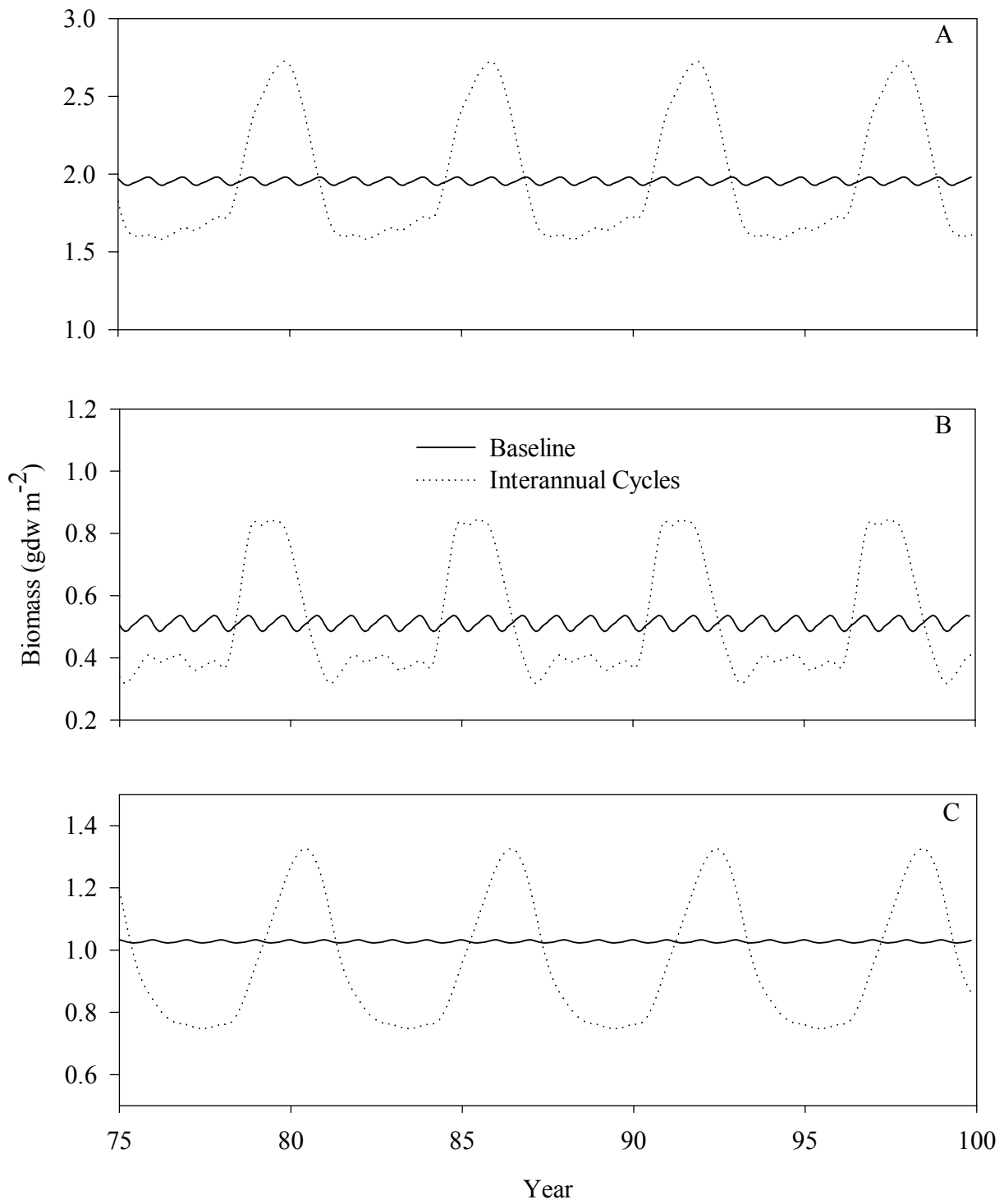

Figure 18: Time-series plots of biomass for the long-term simulations under baseline (alternating high-and low-flow years) and interannual variation in river flow (two high-flow followed by four low-flow years) conditions. Years 75 to 100 are shown. (A) penaeid shrimp, (B) gelatinous zooplankton, and (C) blue crab.



years were grouped, and the number of high-flow versus low-flow years were all important. In the 2 x 2 factorial simulation experiment (Table 11), biomass of the groups exhibited more pronounced cycles when high and low flow years were grouped (four high-flow followed by four low-flow years) than when years were alternating (results of the 40% change are shown in Fig. 21). Blue crab biomass decreased more under a 40% change than under a 20% change, with consistent responses whether the high-flow and low-flow years were alternating or grouped. The magnitude of change and grouping had small effects on carnivorous and piscivorous fish, and interactive effects on marine mammals, with predicted decreases in marine mammal biomass being larger under the grouped conditions. Average biomass of carnivorous fish was essentially similar for the 20% and 40% changes when years were alternating (0.013 and 0.013 gdw m⁻²), and when high and low flow years were grouped. Similarly, average biomass of piscivorous fish was 0.008 gdw m⁻² for 20% to 40% ungrouped and 0.007 gdw m⁻² for 20% and 40% grouped. Average biomass of marine mammals showed an interactive effect, with little effects of flow magnitude under alternating years (0.185 gdw m⁻² under 20% and 0.187 gdw m⁻² under 40%), but a significantly larger decrease in biomass when years were grouped (0.159 gdw m⁻² under 20% versus 0.120 gdw m⁻² under 40%).

The results of the second additional simulation experiment showed that the number of high-flow versus low-flow years also had an effect on the net change in average biomass of top predators. The baseline pattern consisted of two high-flow years (20% increased) followed by four low-flow years (10% decreased). When I reversed this pattern to 4 high-flow years (10% increased) followed by two low-flow years (20% decreased), blue crab, carnivorous fish, piscivorous fish, and marine mammals all showed a net decrease in their average biomass (Fig. 22).

Figure 19: Time-series plots of biomass for the long-term simulations under baseline (alternating high-and low-flow and interannual variation in river flow (two high-flow followed by four low-flow years) conditions. Years 75 to 100 are shown. (A) anchovy, (B) menhaden, (C) spot, (D) croaker, and (E) mullet.

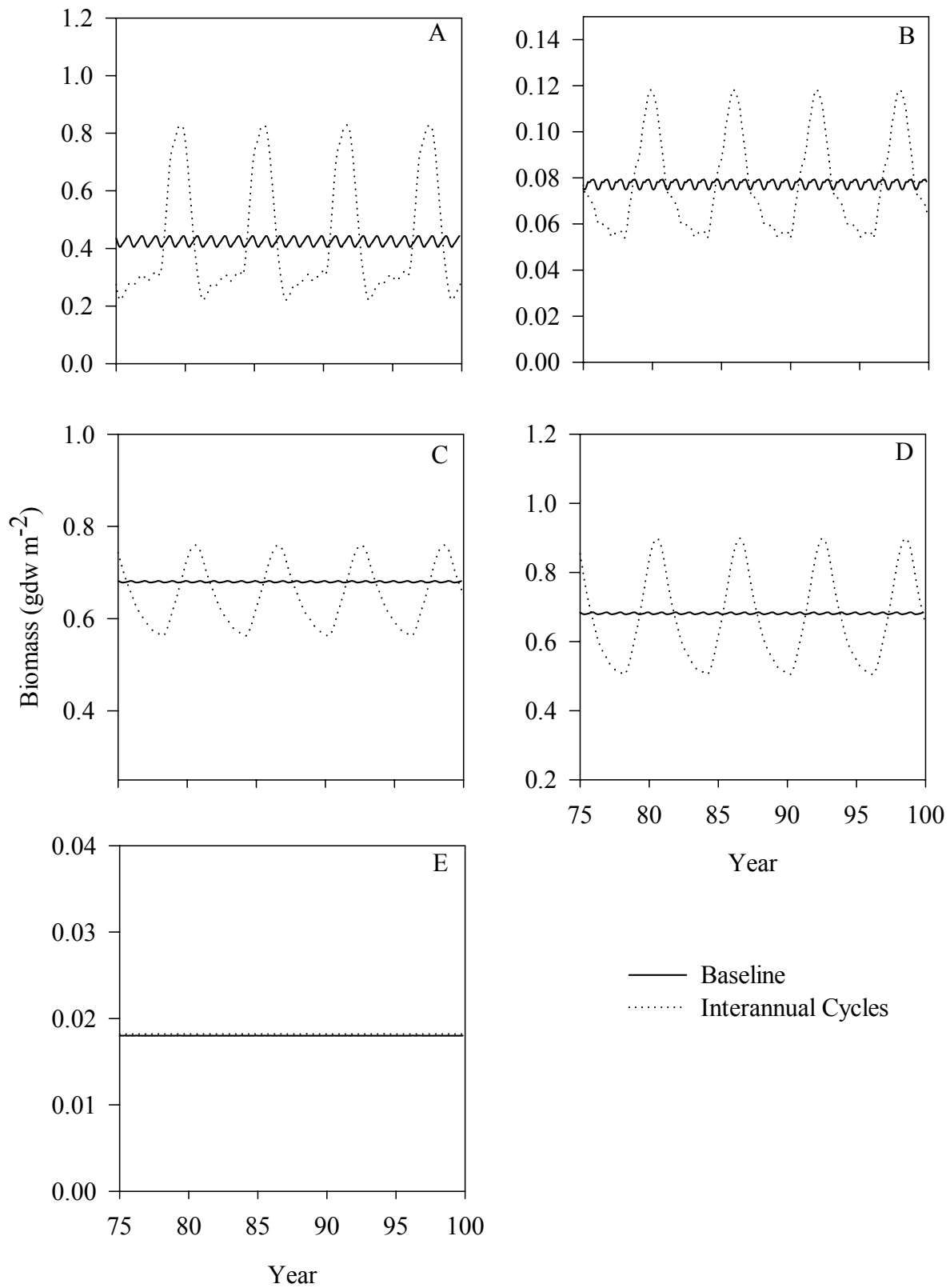
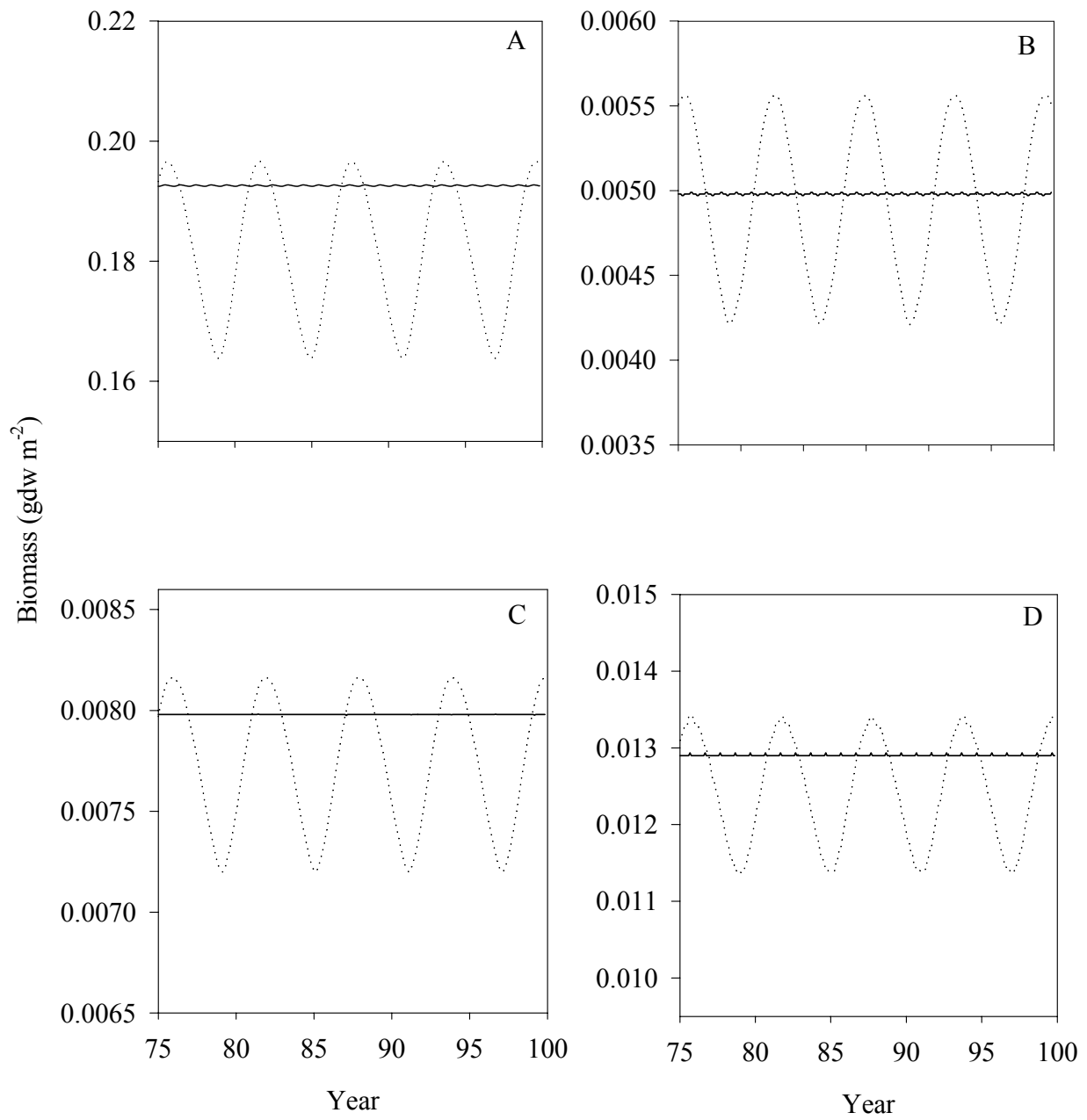

Figure 20: Time-series plots of biomass for the long-term simulations under baseline (alternating high-and low-flow years) and interannual variation in river flow (two high-flow followed by four low-flow) conditions. Years 75 to 100 are shown. (A) marine mammals, (B) benthic fish, (C) piscivorous fish, and (D) carnivorous fish.



— Baseline
 Interannual Cycles

Table 11: Average long-term biomass of blue crab, carnivorous fish, piscivorous fish, and marine mammals for the 2 x 2 factorial simulation experiment with one factor of magnitude (20% or 40%) and the other factor as grouping (alternating or grouped with four high-flow followed by four low-flow years).

		Blue crab	Carnivorous fish	Piscivorous fish	Marine mammals
40	%				
Ungrouped		0.824	0.013	0.008	0.187
20	%				
Ungrouped		0.972	0.013	0.008	0.185
40	% Grouped	0.739	0.010	0.007	0.120
20	% Grouped	0.929	0.011	0.007	0.159

Figure 21: Time-series plots of biomass of (A) blue crab, (B) carnivorous fish, (C) piscivorous fish, and (D) marine mammals for long-term simulations with high and low flow defined as 40% changes from baseline river flow for years ungrouped (alternating high- and low-flow years) and grouped (two high-flow followed by four low-flow years). Years 75 to 100 are shown.

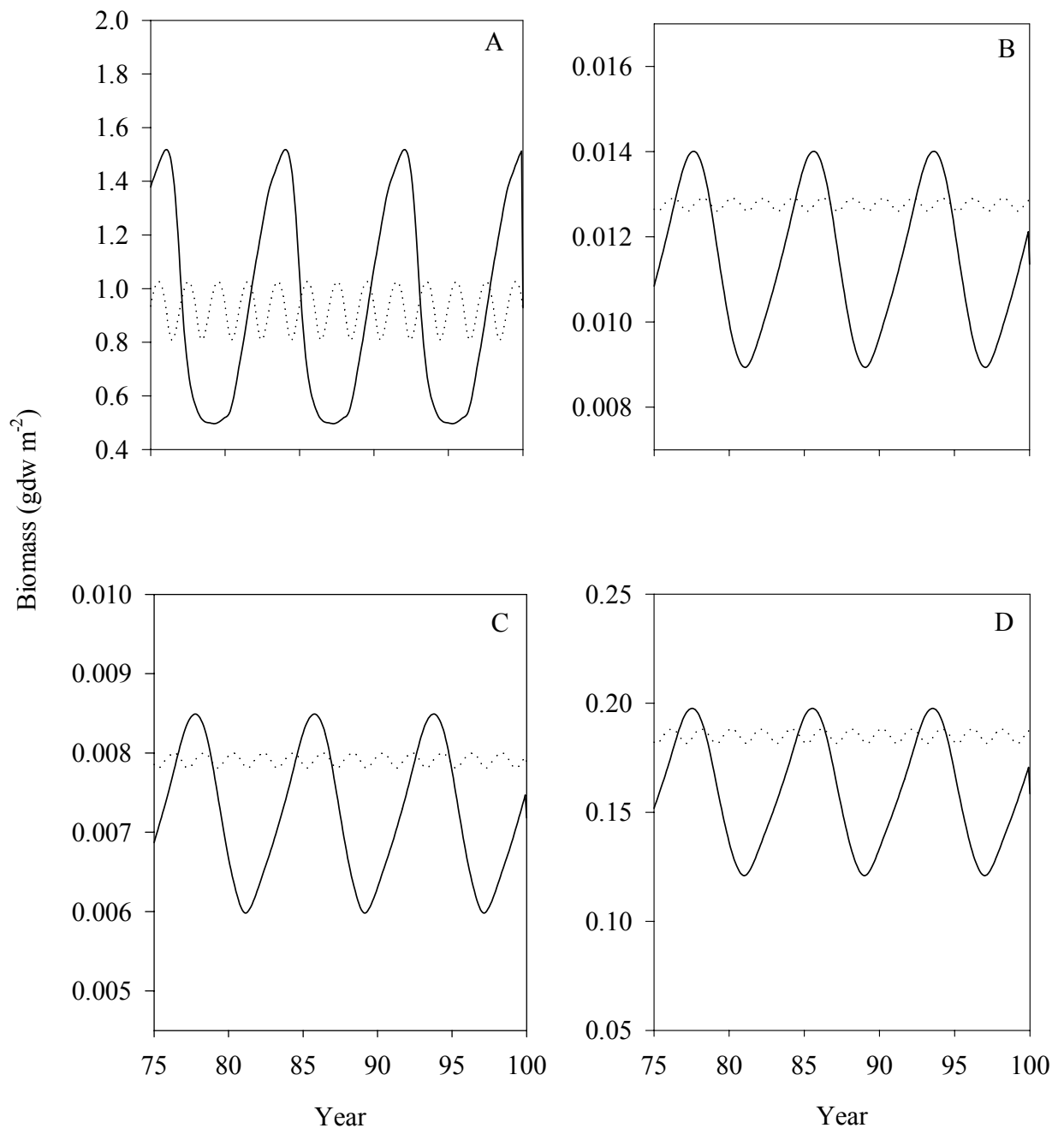

— Grouped Flow
 Ungrouped Flow

Figure 22: Time series plots of biomass (A) blue crab, (B) carnivorous fish, (C) piscivorous fish, and (D) marine mammals for long-term simulations with the baseline grouping of years (two high-flow at 20% change from baseline flow followed by four low-flow at 10%) and with a reversed grouping of years (four high-flow at 10% followed by two low-flow at 20%).

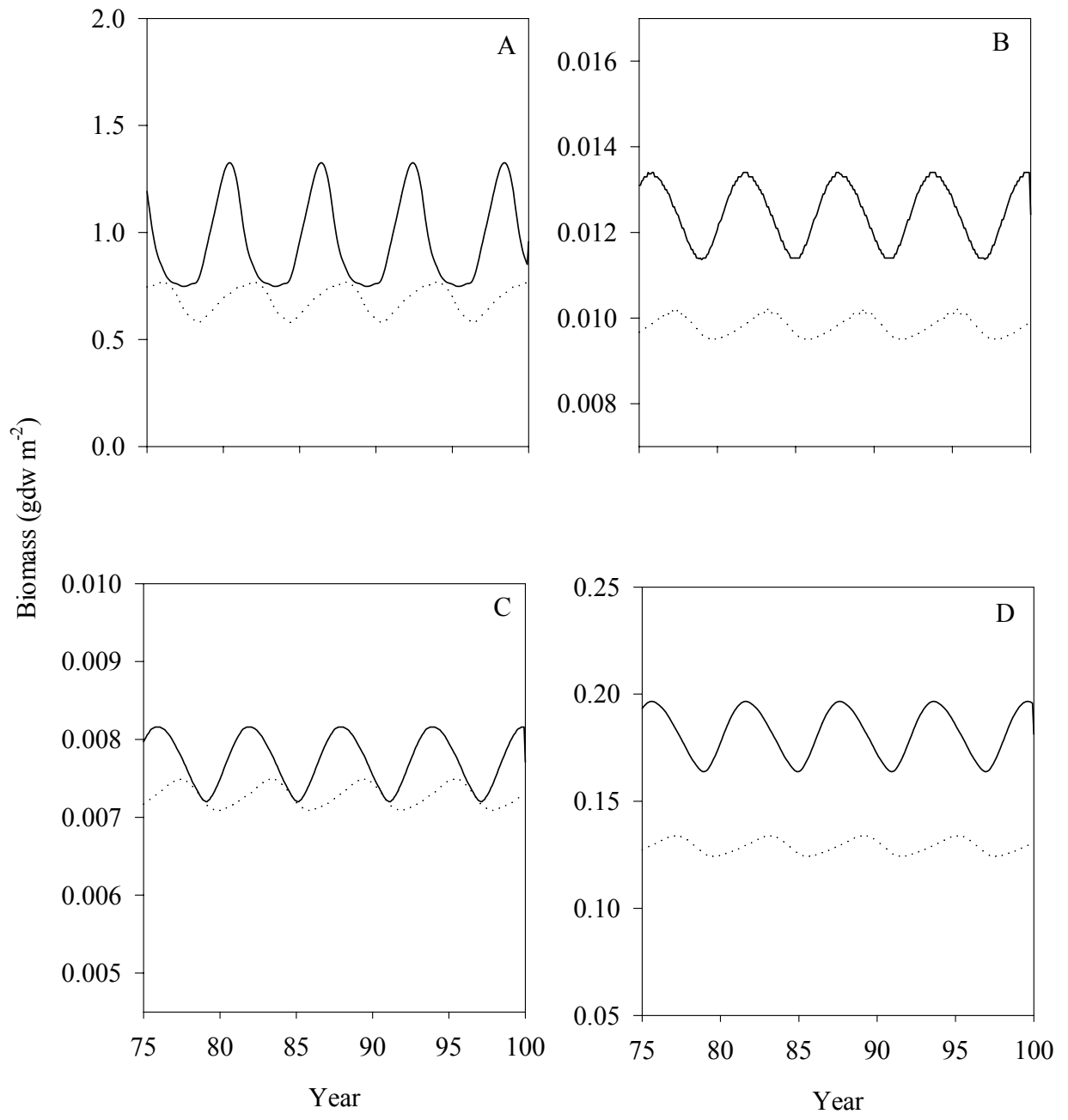

— Natural Flow Cycle
 Reversed Flow Cycle

DISCUSSION

The dynamic nature of estuaries and the seasonal pattern of changing biomass and species compositions leads to questions about how food web structure and function is maintained under these constantly changing conditions (Livingston 2002). I investigated the Weeks Bay food web using season-specific Ecopath models, and by simulating bottom-up perturbations using Ecosim. Both models were configured with the same food web consisting of about 17 functional groups. To summarize model predictions, these functional groups were aggregated into the categories of: top predators (marine mammals, piscivorous fish, carnivorous fish, and benthic fish); forage fish (anchovy, menhaden, mullet, spot and croaker); large invertebrates (blue crab, penaeid shrimp, and gelatinous zooplankton); zooplankton; zoobenthos; phytoplankton; benthic algae; and, detritus. The biomass, production, consumption, Ecopath-derived biomass flow rates, and higher-order indices were compared among the four seasons. Short-term and long-term Ecosim simulations were performed to investigate the bottom-up effects of altered nutrient loadings via a different river-flow pattern. Short-term (20-year) simulations examined the impact of either a single high-flow year or a single low-flow year on each functional group to determine which groups were most vulnerable to extreme alterations in flow. Two long-term (100 year) simulations of altered flow patterns were performed: an increase in within-year extremes of high-flow and low-flow and a cyclic interannual pattern of two high-flow years followed by four low-flow years.

Ecopath

The winter season (January through March) was characterized by generally low biomass and production, and a heavy reliance on the detrital pathway to fuel the consumption of consumers. Top predator and forage fish biomass were an order of magnitude lower in the winter than in any

other season (Table 4). Flow of phytoplankton to detritus during the winter was more than twice that of the lowest season (summer), perhaps due to the low level of zooplankton biomass and the absence of gelatinous zooplankton (Table 6). The stability in the amount of forage fish shunted through detritus and the export of forage fish biomass from the system during the winter indicated that top predator biomass was not constrained by limited forage fish resources in the winter. This could be one factor that allows the average trophic level for each group to remain midrange, even though there is little winter- time internal biomass or production within the system. Utilization of detrital material was greatest by forage fish in the winter, while it was lowest in the winter for all other functional groups (Table 7). The trends in forage fish biomass, flow to detritus, utilization of detrital material, and export indicate that forage fish are a terminal pathway through which recycled detrital nutrients are transferred out of Weeks Bay in the winter.

The spring season (April through June) was characterized by high biomass of the top predators, forage fish, and zoobenthos, high production of zoobenthos and zooplankton, and a heavy reliance on detritus and imported biomass. The high biomass values likely reflect the immigration of larval and juvenile fish and the settlement of benthic organisms, typical of the spring season. High production of zoobenthos is a consequence of high primary production coinciding with high river flow. The large influx of top predator and forage fish biomass led to limitation in the prey resources available to consumers. Increased utilization of detrital material at all levels of the food web (Table 7) and increased dependence on imported material (Table 5) from winter to spring were evidence that limited prey resources drive the development of a more complicated food web in the spring that involves more nutrient recycling. Average trophic levels of the prey consumed by the predatory groups were lowest, as the high biomass of middle and top predators forced consumers to eat prey types more evenly than in the other seasons.

The summer season (July through September) was characterized by low biomass of large invertebrates and zooplankton, high biomass of forage fish and gelatinous zooplankton, and relatively less reliance on detritus. Heavy consumer pressure on zooplankton resulted from high biomass and production of the forage fish groups, and the maintenance of midrange production levels of the large invertebrate groups (Table 4). Large invertebrates also consumed gelatinous zooplankton (Table 5). The spring peak in zooplankton biomass was followed by a summer peak in forage fish biomass. Flow to detritus from the top predator and forage fish groups was highest during the summer and at moderate to low levels for lower-order consumers and primary producers. Middle to high biomass levels of top predators and forage fish are recycled within the system during the summer. Every consumer group from zoobenthos to top predators reached their highest average trophic level in the summer (Table 3). There was a moderate amount of dependence on detritally-recycled nutrients and imported energy sources (Tables 6 and 7). High trophic levels and moderate detrital recycling and utilization of import indicate that the summer food web is comprised of direct producer-consumer interactions, and that biomass of the mid-trophic level species such as forage fish is sufficient to support the high top predator biomass in the system. A web-like food chain requiring large amounts of recycled nutrients is not necessary to support the system in the summer, even though there are high levels of high-order consumer biomass present.

The fall season (October through December) was characterized by high production of top predators. The peak of zooplankton production in the spring, then transferred up through the forage fish in the summer, manifests itself in the high production levels of top predators in the fall (Table 4). Biomass and production of large invertebrates were high in the fall, probably due to blue crab immigration and reproduction. Low levels of zooplankton, zoobenthos, and forage

fish production are an indication of the limitation in prey resources due to decreased primary production at the bottom of the food web in the fall (Tables 4 and 5). Zooplankton production increased once again in the fall when consumer pressure from forage fish decreased due to lower forage fish biomass and increased predation pressure on the forage fish from the high biomass of top predators. Average trophic level of all groups, with the exception of forage fish, was lowest in the fall (Table 3). This pattern is an indication that the number of direct producer consumer food chains that were present during the summer were no longer supportable by available prey, so that in the fall there was increasing reliance on diverse resources by groups at the highest levels of the food web. There was a large amount of detrital recycling through the zoobenthos and large invertebrates (Table 6), and these two groups were the main pathway of detrital material into higher levels of the food web (Table 7). There was little reliance on import during the fall, and even a small amount of export of forage fish biomass. This export may be due to a relaxation of predation pressure from top predators who switched from less abundant forage fish prey to more abundant invertebrate and zoobenthos prey groups.

Season-specific Ecopath snapshots indicate that differences in the way predator and prey resources are partitioned within the food web facilitate maintenance of the functionality of the Weeks Bay ecosystem. Top predators spread consumption among all available prey groups when resources were limited. When there was abundant forage fish biomass, top predators consumed fewer types of prey, concentrating their predation pressure on preferred resources. Trophic analyses on an annual basis of Apalachicola Bay, Perdido Bay, and San Francisco Bay found that similar partitioning of resources among predator groups was a factor in the maintenance of the annual food web when river flow conditions varied from year to year (McEachran et al. 1976; Chao and Musick 1977; MacPherson 1981; see Livingston 2002). The Apalachicola Bay system

is physically and hydrologically similar to Weeks Bay, but both Perdido Bay and San Francisco Bay are larger and deeper systems in which water column stratification may be a contributing factor to differences observed in feeding strategies of the resident fish species. Seasonal analysis of stomach contents of estuarine fishes provide additional evidence that differences in prey utilization across seasons is common in some, but not all, estuarine fish species (Elliot and Hemingway 2002).

High biomass in the spring and summer and reduced biomass in the fall and winter in Weeks Bay was comparable to biomass patterns observed in fish biomass in northern Florida estuaries (Sheridan 1979; Livingston 2002). In Weeks Bay, high-level consumers generally occupied a trophic level between 3.5 and 4, while the trophic level mid-level consumers varied from 2.5 to 3.5. In Ecopath models created for estuarine systems in the southern Gulf of Mexico, Norway, and the northern continental shelf in the Gulf of Mexico (Manickchand-Heileman et al. 1998; Christensen 1995; Browder 1993; Christensen and Pauly 1998), similar functional groups had estimated trophic levels that were comparable to those estimated for Weeks Bay. For example, forage fishes in Weeks Bay occupied an average trophic level between 2.39 (fall) and 2.94 (summer), and trophic levels for forage fish groups from Manickchand-Heileman et al. (1998) ranged from 2.54 for *Engraulidae* to 3.14 for their other fish category.

Detrital recycling is necessary to maintain the system during the period of high ecosystem growth in the summer and during the period of high ecosystem organization during the fall season. Elliot et al. (2002) concluded that a key feature of estuaries is their ability to act as detritus traps to provide food resources for predatory fishes, a finding supported by my seasonal Ecopath models of Weeks Bay. Export of biomass from the system was extremely rare, indicating that there is little surplus biomass in the system. Material exported from the system

originated from the detritus and was shunted across ecosystem boundaries through pathways that terminated in the forage fish groups.

Ecosystem indices by season illustrate a pattern of food web development throughout the year from a low in the winter to a peak of organization in the fall (Table 8). Capacity and overhead peaked in the spring; indicating that spring is a robust season that can recover quickly from perturbations. The high potential for development embodied in high values of capacity and overhead was used up as the system became more organized and the food web became more fully developed until the system reached its peak ascendancy in the fall. The cycle begins again in the winter as the ascendancy, overhead, and capacity were reduced by seasonal shifts in species composition, biomass, and production patterns. In the development of ecosystems sensu Odum (1969), Weeks Bay cycles through a succession of communities: beginning with an initial developmental stage in the winter, undergoing a period of high production, biomass and energy flow through the spring and summer, which then becomes more organized into a climax community in the fall. Baird and Ulanowicz (1989) found a similar pattern of succession in the seasonal dynamics of the Chesapeake Bay estuary. There are few other studies that quantify the seasonal succession of estuarine food webs, so conclusions regarding seasonal patterns of estuarine development must be considered preliminary (Ulanowicz 1996).

Ecosim

Phytoplankton production is directly controlled by river flow in model simulations, but other primary producers and lower trophic level consumers responded and recovered rapidly from pulses of high and low river flow, an indication that these groups are resistant to perturbations in primary production (Tables 9 and 10). The seasonal signal in river flow was evident among the lower trophic levels, while it was completely dampened into a flat line of constant biomass at the

higher trophic levels (Figs. 9 to 12). Higher trophic level consumers exhibited a delayed response to an increase or decrease in river flow, and their recovery from perturbations took much longer than the lower trophic level groups. In some groups, a single pulse of high-flow or low-flow years impacted the amount of biomass in the system for as long as ten years later (eg. carnivorous fish). This protracted recovery time is an indication that the species most sensitive to estuarine eutrophication due to increased nutrient supplies are the top consumers that are also of commercial and recreational importance. It has been postulated that bottom-up forces, such as those simulated in this analysis, are influential factors driving the dynamics of highly reticulated food webs because top-down forces are buffered by the distribution of consumption among higher trophic levels (Strong 1992; Neutel et al. 2002). The quick response and recovery by lower trophic levels and protracted response and recovery time by higher trophic levels in my simulation experiments seems to support this view.

Expanding the temporal scale of the simulations in order to simulate an increase in the severity of within-year extremes of high and low flow revealed that the food web was generally insensitive to alteration of within-year flow patterns (Figs. 13 to 16). Because the amount of water sent through the system in the extreme year simulation was the same as the amount in baseline simulations, the effects of the increased river flow during the wet season and decreased river flow during the dry season essentially counteracted each other. The result was that there was more variable biomass but very little net change in average biomass in response to a more extreme within-year flow pattern. Current climate change models predict an increase in extreme rainfall events (Scavia et al. 2002). These results indicate that the Weeks Bay food web would be relatively insensitive to extreme events if the long-term average rainfall amounts remain at current levels.

An altered interannual pattern that increased flow by 20% during the two years of high-flow and decreased flow by 10% during the four years of low-flow resulted in more variable dynamics of most of the groups, but similar biomass in the lower trophic levels while there was a small net change in the biomass of some of the forage fish groups and top predators. The lower trophic level groups faithfully mimicked the simulated river-flow pattern (Figs. 17 and 18). In the higher trophic levels, cascading of energy up the food web produced a dampening whereby the individual peaks and troughs of each year became single peaks or troughs corresponding to the groups of high-flow and low-flow conditions at higher trophic levels (Figs. 19 and 20). Percent change in average biomass of the lower trophic levels was generally less than one percent, while at higher trophic levels average biomass was increased by as much as 3% (anchovy) and decreased by as much as 6% (marine mammals) (Table 10). The insensitivity of lower trophic level groups to altered interannual patterns of river flow provide further evidence of the resilience of these groups. The small, but consistent, reductions in biomass that were predicted for the higher-order consumers, such as carnivorous and piscivorous fish and marine mammals, suggest these groups have an asymmetric response to variations in river flow. These results illustrate the need for careful consideration of watershed activities that could affect nutrient fluxes into the estuary.

The net decrease in biomass of some of the upper trophic level groups raised questions about what factors caused this asymmetric response: was it the changes in magnitude of the high-flow and low-flow years, the grouping of high-flow and low-flow years together, or the number of high-flow and low-flow years? Two additional simulation experiments provided evidence that all three contributed to the asymmetrical response (net change in biomass) of the upper trophic level groups. Biomass of the groups exhibited more pronounced cycles when high-flow and low-

flow years were grouped (four high-flow followed by four-low flow years) than when years were alternating (Fig. 21). Average biomass of blue crab and marine mammals decreased when high-flow and low-flow years were defined as 40% changes compared to 20% changes in river flow, with larger changes occurring when years were grouped (Table 11). Reversing the pattern of high-flow and low-flow years to four high-flow years followed by two-low flow years also resulted in net decrease in the average biomass (Fig. 22). These simulation results provide evidence that changes in the amount of precipitation or in nutrient concentrations in the tributary rivers can have complicated effects on the food web, including potentially net decreases in average biomass of some important species. Livingston et al. (1997) conducted trophic analyses of ten years of field data from the Apalachicola Bay estuary in which organisms were grouped into trophic levels ranging from second (eg. zooplankton) to third-order consumers (eg. seatrout) based on stomach contents. They found that lower trophic levels responded directly to river-dominated forcing functions, while higher trophic levels had a delayed response that was based on biological factors. Livingston et al. also found that two consecutive years of drought resulted in decreased biomass of higher order consumers, the effects of which were detectable for the next two years. Changes in nutrient loadings are of particular concern because of the potential future development of the Weeks Bay watershed and possible precipitation and weather effects of global climate change (Kennedy et al. 2002; Scavia et al. 2002).

Caveats and Limitations

While the Ecopath and Ecosim simulation package is a powerful tool, there are some limitations to the ecosystem modeling approach used. The static Ecopath snapshots provide some answers to theoretical questions about energy flow and ecosystem development, and can lead to more thoughtful questions and hypotheses about a specific system or component. The

requirement of steady-state and the focus on predators consuming prey as the basis of all food web interactions are clearly stated assumptions, but limit the questions that can be addressed.

Ecosim removes the steady-state requirement, but in my application to a small, open estuarine system revealed some limitations in the current version of the Ecosim software. The potential for large influence of boundary conditions in my Weeks Bay application complicated the interpretation of Ecosim results and limited the scope and realism of Ecosim scenarios that could be explored. Seasonal shifts in species composition as transient species emigrate and immigrate were the most difficult problem to deal with when using the Ecosim model. I was unable to easily force the seasonal patterns of juvenile fish movements into and out of the estuary. However, the Ecosim component of this modeling package is constantly under revision (e.g. Walters et al. 2000). When considering the results of the Ecosim simulations of Weeks Bay, it must be understood that these predictions are as if the food web in Weeks Bay is operating in isolation so that the biomass and production of a group from one year are the source of the population for the next year. While model simulations under such conditions are informative, more realistic simulations would have incorporated seasonal movement patterns of the forage fish and top predator groups into and out of the system.

While the development of an easily applied ecological model of an ecosystem is an admirable goal, the difficulties of attempting to incorporate many options for the user in one package were evident when using this software. The influence of abiotic factors, such as seasonal temperature variation, salinity gradients, areas of hypoxia, etc. were not possible to simulate in the current version of this software. Considerations beyond those of feeding interactions within the food web and patterns in primary productivity were impossible in time-dynamic simulations. The dangers of creating a simple "black-box" into which numbers are fed and numbers come out cannot be

ignored. Models are useful simplifications of the natural world that are necessary for improving our understanding and management of resources, but careless application and interpretation of model results beyond the scope of the data and capabilities of the model may be too easy with off-the-shelf software such as Ecopath and Ecosim.

Concluding Remarks

Through quantification of energy flow through food webs, the effect of changing species composition across seasons can be determined, which helps to answer the question: does the structure and function of a community change in concert with changes in nutrient supply and species composition (DeAngelis et al. 1988)? The seasonal Ecopath snapshots in this study indicate that the structure of the Weeks Bay food web is resistant to perturbation, allowing the maintenance of a functional ecosystem across the seasonally-driven changes in environmental conditions and in species compositions and biomasses. Though there are limited studies of seasonality in estuarine food webs, there is some evidence that Weeks Bay is not unique. In one of the few studies that examined seasonality in estuarine food webs, Baird and Ulanowicz (1989) found that, like Weeks Bay, there are seasonal changes in the reticulation of the food web and in the importance of detritus.

Time-dynamic simulations across an expanded temporal scale illustrated that primary producers and lower trophic level consumers were resilient to short pulses in river flow (primary production) and to variation in flow within and among years. Commercially and recreationally important species at the top of the food web were more sensitive to short-term pulsed events than the other species in the system, but did eventually return to their equilibrium state. Long-term perturbations, as simulated within the limitations of the Ecosim model, were shown to have the potential to reduce the long-term average biomass of important species in this system. While net

changes in long-term average biomass were relatively small, they are suggestive of possible shifts in key species within the food web, a finding supported by field evidence in an observed food web in the Apalachicola Bay estuary (Livingston et al. 1997).

Anthropogenic stressors in the Weeks Bay watershed are projected to increase as the human population continues to grow along this portion of the Alabama coast, and climate change models predict that there is a potential for alterations of precipitation patterns in this region. My analysis illustrates the importance of careful land- and water-use management in order to ensure the viability of the dynamic food web of Weeks Bay, and likely other small, shallow estuaries.

LITERATURE CITED

- Bain, M. B. & Robinson, C.L. (1990). *Abiotic and biotic factors influencing microhabitat use by fish and shrimp in Weeks Bay National Estuarine Research Reserve*. Washington, D.C., U.S. Department of Commerce, NOAA, National Ocean Service.
- Baird, D. and Ulanowicz, R.E. (1989). "The seasonal dynamics of the Chesapeake Bay ecosystem" *Ecological Monographs* 59 (4): 329-364.
- Brackin, M.T. (2001). M.S. Thesis, University of South Alabama. *Density, growth, and biomass production of Atlantic croaker, spot, penaeid shrimp, and blue crab in the Weeks Bay National Estuarine Research Reserve, Alabama*.
- Browder, J.A. (1993). A pilot model of the Gulf of Mexico continental shelf, 279-284. In V. Christensen and D. Pauly (eds.) *Trophic models of aquatic ecosystems*. ICLARM Conf. Proc. 26: 390p.
- Carpenter, S. R. (1990). "Large-scale perturbations: opportunities for innovation." *Ecology* 71(6): 2038-2043.
- Chesney, E.J., Baltz, D.M., and Thomas, R.G. (2000). "Louisiana estuarine and coastal fisheries and habitats: perspectives from a fish's eye view." *Ecological Applications* 10(6): 350-366.
- Christensen, V. (1995). "Ecosystem maturity - towards quantification." *Ecological Modelling* 77: 3-32.
- Christensen, V. and Pauly, D. (1998). "Changes in models of aquatic ecosystems approaching carrying capacity." *Ecological Applications* 8(1 Supplement): S104-S109.
- Christensen, V. and Pauly, D. (eds.) (1993). *Trophic Models of Aquatic Ecosystems*. ICLARM Conf. Proc. 26, 390 pp.
- Christensen, V. and Pauly, D. (1992). "ECOPATH II - a software for balancing steady-state ecosystem models and calculating network characteristics." *Ecological Modelling* 61: 169-185.
- Christensen, V., Walters, C.J., Pauly, D. (2000). *Ecopath with Ecosim: a User's Guide*. Fisheries Centre, University of British Columbia, Vancouver, Canada, ICLARM, Penang Malaysia.
- Clark, J. S., Carpenter, S.R., Barber, M., Collins, S., Dobson, A., Foley, J.A., Lodge, D.M., Pascual, M., Pielke Jr., R., Pizer, W., Pringle, C., Reid, W.V., Rose, K.A., Sala, O., Schlesinger, W.H., Wall, D.H., Wear, D. (2001). "Ecological forecasts: an emerging imperative." *Science* 293: 657-660.

- Cottingham, K.L. and Schindler, D.E. (2000). "Effects of grazer community structure on phytoplankton response to nutrient pulses" *Ecology* 81 (1): 183-200.
- Day, J. W., Hall, C. A. S., Kemp, W. M., Yanez-Arancibia, A.(1989) *Estuarine Ecology*. John Wiley and sons, New York, USA.
- DeAngelis, D.L. (1988), "Strategies and difficulties of applying models to aquatic populations and food webs" *Ecological Modelling* 43: 57-73.
- Edgar, G.J. (1990). "The use of the size structure of benthic macrofaunal communities to estimate faunal biomass and secondary production" *Journal of Experimental Marine Biology and Ecology* 137: 195-214.
- Elliot, M. and Hemingway, K.L. (eds.) (2002). *Fishes in Estuaries*. Iowa State University Press: A Blackwell Science Co., Ames, Iowa, USA.
- Froese, R. and D. Pauly. Editors. (2001). FishBase. World Wide Web electronic publication. www.fishbase.org May 2001.
- Hunter, M.D. and Price, P.W. (1992). "Playing chutes and ladders: heterogeneity and the relative roles of bottom-up and top-down forces in natural communities" *Ecology* 73 (3): 724-732
- Kennedy, V.S., Twilley, R.R., Kleypas, J.A., Cowan, J.H., Hare, S.R. (2002). *Coastal and marine ecosystems and global climate change: potential effects on US resources*. Pew Center on Global Climate Change, Arlington, VA. 52 p.
- Livingston, R.J. (2002). *Trophic Organization in Coastal Systems*. CRC Press, Boca Raton, FL, USA.
- Livingston, R.J, Niu, X., Lewis, G. III, and Woodsum, G.C. (1997). "Freshwater input to a Gulf estuary: long-term control of trophic organization" *Ecological Applications* 7 (1): 277-299.
- Manickchand-Heileman, S., Soto, L.A., Escobar, E. (1998). "A preiliminary trophic model of the continental shelf, south-western Gulf of Mexico. *Estuarine, Coastal and Shelf Science* 46: 885-899.
- Manickchand-Heileman, S., Arreguin-Sanchez, F., Lara-Dominguez, and A., Soto (1998). "Energy flow and network analysis of Terminos Lagoon, SW Gulf of Mexico. *Journal of Fish Biology* 53(Suppl. A): 179-197
- McIsaac, G.F., David, M.B., Gertner, G.Z., and Goolsby, D.A. (2001). "Eutrophication: Nitrate flux in the Mississippi River." *Nature*. 414: 166-167
- Micheli, F. (1999). Eutrophication, fisheries, and consumer-resource dynamics in marine pelagic ecosystems. *Science* 285: 1396-1398.

- Miller-Way, T., Dardeau, M., Crozier, G. (1996). *Weeks Bay National Estuarine Research Reserve: An Estuarine Profile and Bibliography*, 126p.
- Niquil, N., Arias-Gonzalez, J.E., Delesalle, B., Ulanowicz, R.E. (1999). "Characterization of the planktonic food web of Takapoto Atoll lagoon, using network analysis." *Oecologia* 118: 232-241.
- Noel, J.E. (2000). M.S. Thesis, University of South Alabama. *Biomass production of bay anchovy (*Anchoa mitchilli*) and Gulf menhaden (*Brevoortia patronus*) in Weeks Bay, Alabama and their potential roles in nutrient translocation.*
- Neutel, A-M, Heesterbeek, J.A.P., and de Ruiter, P.C. (2002). "Stability in real food webs: weak links in long loops" *Science* 296: 1120-1123.
- Odum, E. P. (1969). "The strategy of ecosystem development." *Science* 164: 262-270.
- Pauly, D., Palomeres, M. L., Froese, R., Sa-a, P., Vakily, M., Preikshot, D., Wallace, S. (2001). "Fishing down Canadian aquatic food webs." *Canadian Journal of Fisheries and Aquatic Science* 58: 51-62.
- Polovina, J.J. (1984). "Model of a coral reef ecosystem I. The Ecopath model and its application to French Frigate Shoals. *Coral Reefs* 3:1-11.
- Rose, K.A., Cowan, J.H. Jr., Clark, M.E., Houde, E.D., Wang, S.-B. (1999) "An individual-based model of bay anchovy population dynamics in the mesohaline region of Chesapeake Bay" *Marine Ecology Progress Series* 185: 113-132.
- Scavia, D., Field, J.C., Boesch, D.F., Buddemeier, R.W., Burkett, V., Cayan, D.R., Fogarty, M., Harwell, M.A., Howarth, R.W., Mason, C., Reed, D.J., Royer, T.C., Sallenger, A.H., and Titus, J.G. (2002) "Climate change impacts on U.S. coastal and marine ecosystems" *Estuaries* 25 (2): 149-164.
- Schoenly, K. and Cohen, J.E. (1991). "Temporal variation in food web structure: 16 empirical cases" *Ecological Monographs* 61 (3): 267-298.
- Schreiber, R.A. (1999). M.S. Thesis, University of South Alabama. *The contribution of the benthic microalgae to primary production in Weeks Bay.*
- Sheridan, P.F. (1979). "Trophic resource utilization by three species of sciaenid fishes in a northeast Florida estuary" *Northeast Gulf Science* 3: 1-15
- Straile, D. (2002). "North Atlantic Oscillation synchronizes food-web interactions in central European lakes." *Proceedings of the Royal Society of London B* 269: 391-395.

- Strong, D.R. (1992). "Are trophic cascades all wet? Differentiation and donor-control in speciose ecosystems" *Ecology* 73(3): 747-754
- Ulanowicz, R.E. (1996). "Trophic flow networks as indicators of ecosystem stress" In Polis, G.A. and Winemiller, K.O. (eds.) *Food Webs: Integration of Patterns and Dynamics* Chapman and Hall New York, New York, USA.;
- Ulanowicz, R. E. (1980). "A hypothesis on the development of natural communities." *Journal of Theoretical Biology* 85: 223-245.
- Walters, C., Pauly, D., Christensen, V., Kitchell, J.F. (2000). "Representing density dependent consequences of life history strategies in aquatic ecosystems: EcoSim II." *Ecosystems* 3: 70-83.
- Walters, C.M., Christensen, V., Pauly, D. (1997). "Structuring dynamic models of exploited ecosystems from trophic mass-balance assessments." *Reviews in Fish Biology and Fisheries* 7: 139-172.
- Wolff, M., Koch, V., Isaac, V. (2000). "A trophic flow model of the Caete mangrove estuary (North Brazil) with considerations for the sustainable use of its resources." *Estuarine, Coastal and Shelf Science* 50: 789-803.

APPENDIX: ADDITIONAL EQUATIONS

Total system throughput:

T = total export + total consumption + total respiration + total flow to detritus

Ascendency:

$$A = T * I$$

where T is total system throughput and I is a measure of the average mutual information within the system and is calculated as:

$$I = \sum_{i=1, j=1}^n f_{ij} Q_i \log \left(f_{ij} / \sum_{k=1}^n f_{kj} Q_k \right)$$

where f_{ij} is the fraction of total flow from j to i that is represented by:

$$f_{ij} = T_{ij} / \sum_{k=1}^n T_{kj}$$

and Q_i is the probability that a unit of energy passes through i , or:

$$Q_i = \sum_{k=1}^n T_{ki} / \sum_{l=1, m=1}^n T_{lm}$$

Development Capacity:

$$C = H * T$$

where H is called the statistical entropy of the system and is calculated as

$$H = \sum_{i=1}^n Q_i \log Q_i$$

VITA

Laura Althausser was born in Hayward, California, on November 11, 1971. Upon graduation from high school in 1989, she joined the United States Navy for four years where she was an aviation electronics technician. She graduated with Bachelor of Science degrees in both marine biology and marine fisheries management from Texas A&M University in 1999. She came to Louisiana State University in January of 2000 as a cooperative education student through the National Marine Fisheries Service laboratory in Galveston, Texas.